

Project	<b>IEEE 802.16 Broadband Wireless Access Working Group</b> < <a href="http://ieee802.org/16">http://ieee802.org/16</a> >		
Title	<b>Ad hoc on SSURF transmission</b>		
Date Submitted	<b>2008-01-15</b>		
Source(s)	Shulan Feng Hisilicon Tech. Co., LTD Bld.17, No.8, Dongbeiwang West Road, Hai-Dian District, Beijing, P. R. China	Voice: Fax: e-mail to :	+86-10-82829151 +86-10-82829075 <a href="mailto:fengsl@hisilicon.com">fengsl@hisilicon.com</a>
Re:	IEEE 802.16 Working Group Letter Ballot #29		
Abstract	Ad hoc on SSURF message transmission.		
Purpose	Discussion and accept.		
Notice	<i>This document does not represent the agreed views of the IEEE 802.16 Working Group or any of its subgroups. It represents only the views of the participants listed in the "Source(s)" field above. It is offered as a basis for discussion. It is not binding on the contributor(s), who reserve(s) the right to add, amend or withdraw material contained herein.</i>		
Release	The contributor grants a free, irrevocable license to the IEEE to incorporate material contained in this contribution, and any modifications thereof, in the creation of an IEEE Standards publication; to copyright in the IEEE's name any IEEE Standards publication even though it may include portions of this contribution; and at the IEEE's sole discretion to permit others to reproduce in whole or in part the resulting IEEE Standards publication. The contributor also acknowledges and accepts that this contribution may be made public by IEEE 802.16.		
Patent Policy	The contributor is familiar with the IEEE-SA Patent Policy and Procedures: < <a href="http://standards.ieee.org/guides/bylaws/sect6-7.html#6">http://standards.ieee.org/guides/bylaws/sect6-7.html#6</a> > and < <a href="http://standards.ieee.org/guides/opman/sect6.html#6.3">http://standards.ieee.org/guides/opman/sect6.html#6.3</a> >. Further information is located at < <a href="http://standards.ieee.org/board/pat/pat-material.html">http://standards.ieee.org/board/pat/pat-material.html</a> > and < <a href="http://standards.ieee.org/board/pat">http://standards.ieee.org/board/pat</a> >.		

## Ad hoc on SSURF transmission

*Shulan Feng*

*HiSilicon*

### Introduction

We have an ad hoc on SSURF transmission and contribution C802.16h-07/102 has presented during meeting #52. Some comments are proposed during the face to face discussion and the TG decided to continue the ad hoc on SSURF transmission and reciprocal interference identification.

This contribution focuses on SSURF transmission only. Two SSURF message transmission opportunity maps are given. For one case, SSURF message transmission opportunity maps to 21 uplink slots and can contain all IEs of SSURF message in one transmission opportunity. In other case, SSURF message transmission opportunity maps to 12 uplink slots and can contain part of the IEs of SSURF message in one transmission opportunity.

### Calculate the number of bytes to transmit the SSURF message

In the contribution C802.16h-07/102, we have gotten the result that for IPV6, 392 bits is needed to transmit the SSURF message. However, C802.16h-07/102 has considered that many IEs in SSURF message are TLV encoded, so additional 12 bytes is needed to transmit the SSURF message as shown in figure 1, that is 488 bits for IPV6 and 408 bits for IPV4.

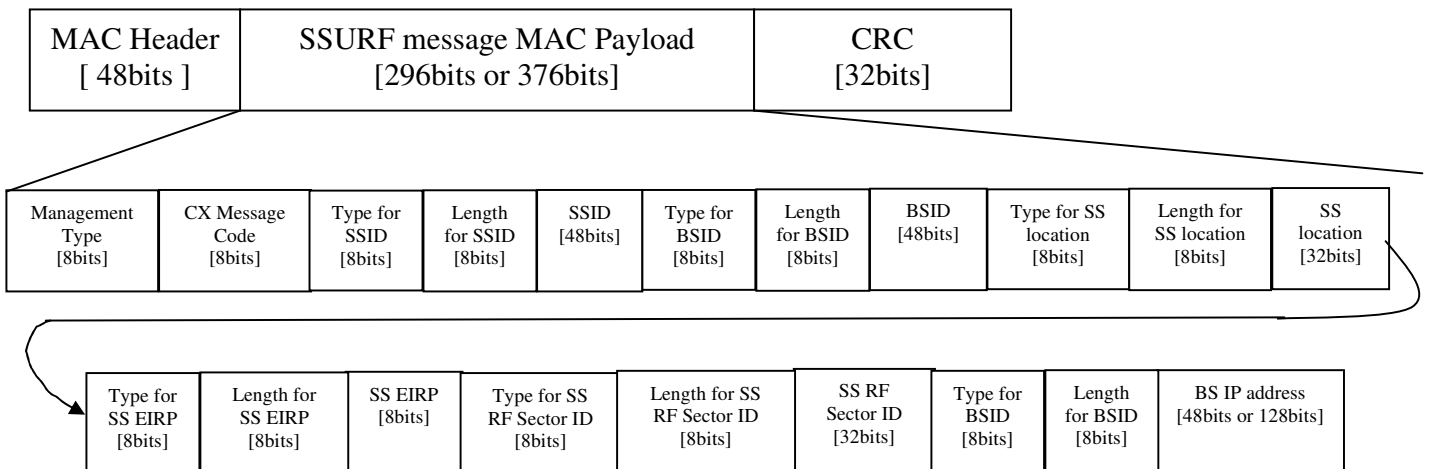

Figure 1

There are 48 data subcarrier each uplink slot (section 8.4.6.2.1) and there are 17 subchannels every 3 OFDMA symbols.

For 5MHz bandwidth, the number of OFDMA symbol in one frame is 47. Following the 60%/40% rule, we can get that the number of OFDMA symbol of uplink is 18 or 19.

So if we set the number of OFDMA symbols for CMI\_U is 18, we can get  $17*6=102$  uplink slots available for SSURF.

If we use QPSK 1/2 CC for SSURF, one information bit will need one data subcarrier to carrier. So to transmit one SSURF message, 488 data subcarriers are needed. So we need 11 uplink slots for IPV6.

If we use QPSK 1/2 CC and repetition code of 2 for SSURF, one information bit will need two data subcarrier to carrier. So to transmit one SSURF message, 976 data subcarriers are needed. So we need 21 uplink slots for IPV6. So if we specify every 21 uplink slots is a SSURF transmission opportunity, there are 4 SSURF transmission opportunity every CMI\_U zone.

## Proposed solution 1

Just following the way proposed in contribution C802.16h-07/102 with new SSURF message length to transmit the SSURF message. So we can get following conclusion.

1. Following PHY parameters are used for SSURF message transmission. Channel Bandwidth: 5MHz; FFT Size: 512; CP: 1/8 [ 1/4 is not mandatory in WiMAX mobile profile ]; PUSC: use PUSC in 8.4.6.2.1; Partitioning of subcarriers into subchannel: following the way specified in 8.4.6.2.2 with UL\_PermBase= 0;
2. Defined the length of CMI\_U is 16 OFDM symbols.
3. QPSK 1/2 CC and repetition code of 2 is used for SSURF transmission.
4. Every 21uplink slots are defined as a SSURF transmission opportunity.
5. The first SSUFR transmission opportunity in CMI\_U is start at the lowest subchannel and lowest OFDMA slot in the CMI\_U zone. The SSURF transmission opportunity continues mapping with OFDMA symbol index is increased. When the edge of the UL zone is reached, continue the mapping from the lowest numbered OFDMA symbol in the next available subchannel. The figure 2 shows the transmission opportunity allocation map.

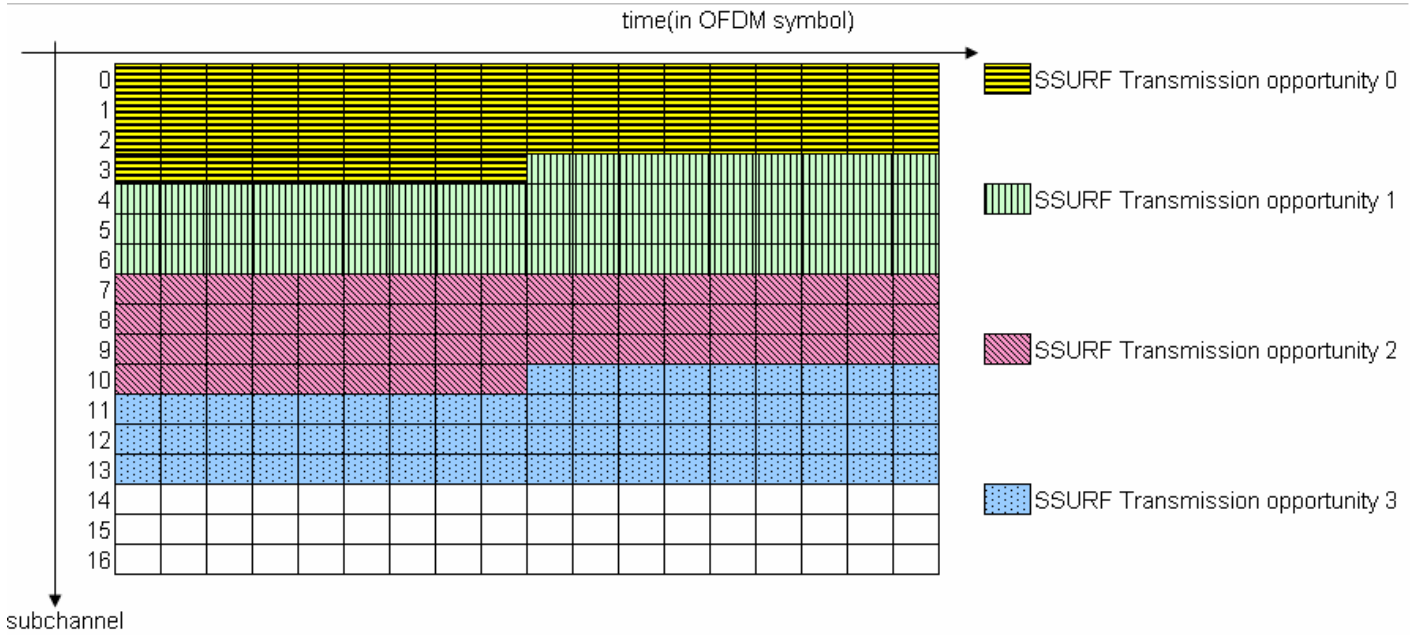

Figure 2

- Modified the table 108ak in section 6.3.2.3.72 to tell the SS during which SSURF transmission opportunity it will send SSURF message.

### Proposed solution 2

The full length of SSURF message is 488 bits and there are only 4 transmission opportunities available only based on above calculation. However, we can short the length of SSURF transmission opportunities by transmitting not all the IEs of SSURF messages. For example, we can set the length of SSURF transmission opportunity is 12 uplink slots as shown in figure 3. So SS can transmit SSID, BSID and SS location information during its first SSURF transmission opportunity, and transmit SS EIRP, RF sector ID and IP address (IPv4) during its second SSURF transmission opportunity.

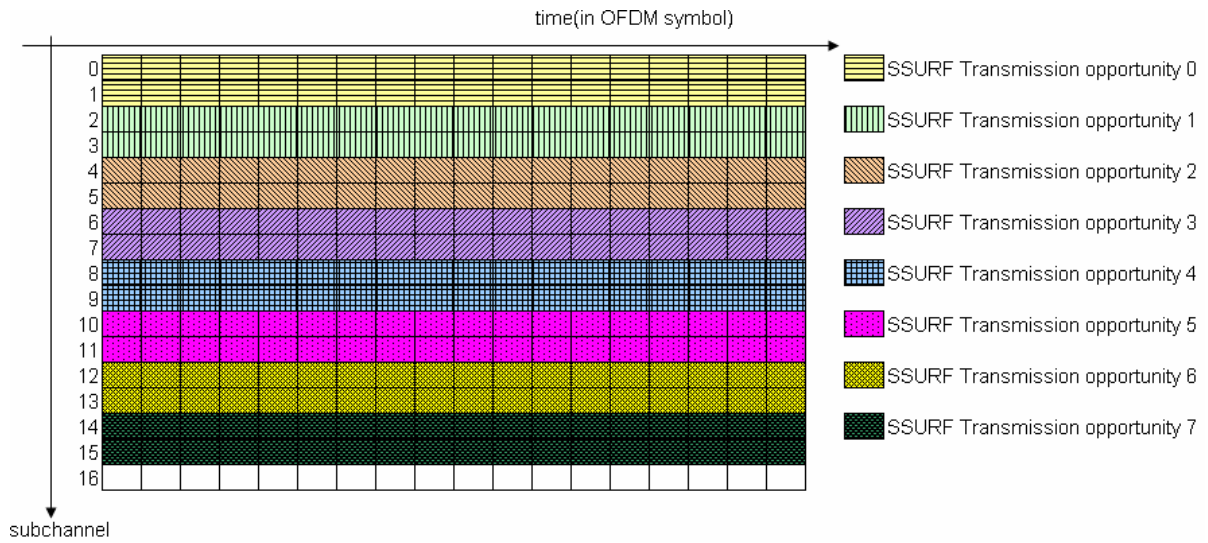

Figure 3

**Proposed Text**

*[During the discussion of email, John suggested to reserve some TBD bits for future use. And he also suggest not use the repetition coding. So the text below may be modified during the Levi meeting.]*

**6.3.2.3.72 CX-UL-MAP (CX UL MAP) message**

The CX-UL-MAP message defines the access to the UL channel and has an extended scope and flexibility in comparison with the UL-MAP Message. The CX-UL-MAP message shall be as shown in *Table h 108ak*.

108ak—CX-UL-MAP message format

Syntax	Size(bits)	Notes
CX-UL-MAP_Message_Format() {		
Management Message Type = 77	8	
Reserved	8	Shall be set to zero.
UCD Count	8	
Begin PHY-specific section {		See applicable PHY subclause.
if (WirelessMAN-OFDMA) {		
No. OFDMA symbols	8	Number of OFDMA symbols in the UL subframe
}		
for ( $i=1; i \leq m; i++$ ) {		
for ( $j = 1; j \leq n; j++$ ) {		permutation zone.
Allocation Start Time	32	

UL transmission type	4	0 - No condition 1 - Radio power at the receiver for conditional transmission 2 - Radio Signature transmitted by this system - no condition 3 - Radio Signature transmitted by another system - no condition 4 - CXCC sub-channel 1, primary synchronization 5 - CXCC sub-channel 1, no transmission 6 - CXCC sub-channel 2, BSD transmission 7 - CXCC subchannel 3, secondary sync 8 - CXCC sub-channel 3, BS_NUBC with frequency keying 9 - CXCC sub-channel 3, NACK transmission 10 - CXCC sub-channel 4, Radio Signature 11-15 - Reserved
if (Conditional UL transmission type = 001) {		
Max power level	8	Negative value, in dBm
}		
if ( UL transmission type = 110		
SSURF transmission opportunity	8	<a href="#">Denote the SSURF message transmission opportunity in CX_CMI_U.</a>
}		
UL-MAP_IE()	variable	
}		For each UL-MAP element 1 to <i>n</i>
}		For each UL-MAP element 1 to <i>m</i> .
}		See corresponding PHY specification.
if !(byte boundary) {		
Padding Nibble	4	
}		Padding to reach byte boundary.
}		

### 15.3.3.5 Subscriber Station Uplink Radio Frequency (SSURF) Message

Subscriber Station Uplink RF (SSURF) messages are the primary means by which a system defines the extent of the interference caused by its subscriber stations to neighboring base stations and coexistence community members. It is demodulated and effectively sensed by the affected base stations. The message is sent on a periodic basis in the CX\_CMI\_U(1-3) when requested to by the Base Station and the transmissions can be maintained over a number of Tcxcc cycles, depending on the number of SS the BS controls. All of the SS should have an opportunity to transmit SSURF messages in order to facilitate their detection as interference by other systems. When received as interference at foreign base stations, the demodulated SSURF provides that station with its specific identity and the proxy IP address of the BS controlling it.

The monitoring process for foreign interfering SSURF messages is undertaken by the Base Station. A BS (system  $n$ ) will monitor  $CX\_CMI\_U(n-1)$  and  $CX\_CMI\_U(n+1)$  in a system where  $n=3$  (max). The BS also monitors its own  $CX\_CMI\_U(n)$ , but only for foreign SSURF from co-channel systems that have claimed the same slot. Under most circumstances this should not occur since the IBS undergoes an extensive CMI claiming procedure (15.3.3.3), however, there is always the possibility of sporadic interference which must be identified. To facilitate such detection the scheduling of uplink SSURFs by the controlling BS should be such that the  $CX\_CMI\_U(n)$  slot is never fully occupied with its own SSURF messages in order to allow the opportunity for other foreign SSURFs to be detected without collision (see 15.3.3.1 and Figure h 35).

To send a SSURF message by a SS, the SS is granted an allocation in a UL subframe corresponding to subchannel 2 of the coexistence channel, where the allocation start time in UL-MAP will be the start of uplink sub-frame. These uplink grants for sending SSURF are unicast to SS. SS sends the SSURF by using this grant in a CXCC subchannel 2 frame. A long preamble needs to be added before the SSURF message [for wirelessMAN-OFDM PHY](#). Here the preamble preceding to the SSURF also uses a predefined CP.

[For wirelessMAN-OFDM PHY](#), Any interfered-with BS ( $n$ ) while in listen mode on  $CX\_CMI\_U(n+/-1)$ , if detecting any preamble (REF1 and REF2), by using a predefined CP (cyclic prefix), and by using a predefined modulation QPSK1/2, will detect the SSURF.

[For wirelessMAN-OFDMA PHY](#), the following PHY parameters are used for SSURF message transmission: Channel Bandwidth: 5MHz; FFT Size: 512; CP: 1/8; Modulation Type: QPSK; FEC Type: 1/2 CC; Repetition Code Rate: 2X; PUSC: use PUSC in 8.4.6.2.1; Partitioning of subcarriers into subchannel: following the way specified in 8.4.6.2.2 with UL PermBase= 0.

[CX\\_CMI\\_U is the last 18 OFDMA symbols in a 5ms frame. Every 21 uplink slots are defined as a SSURF transmission opportunity in CX\\_CMI\\_U zone. So every CX\\_CMI\\_U zone contains 4 SSURF transmission opportunities. The first SSURF transmission opportunity in CX\\_CMI\\_U is start at the lowest subchannel and lowest OFDMA slot in the CMI\\_U zone. The SSURF transmission opportunity continues mapping with OFDMA symbol index is increased. When the edge of the UL zone is reached, continue the mapping from the lowest numbered OFDMA symbol in the next available subchannel. The following figure shows the SSURF transmission opportunity allocation map.](#)

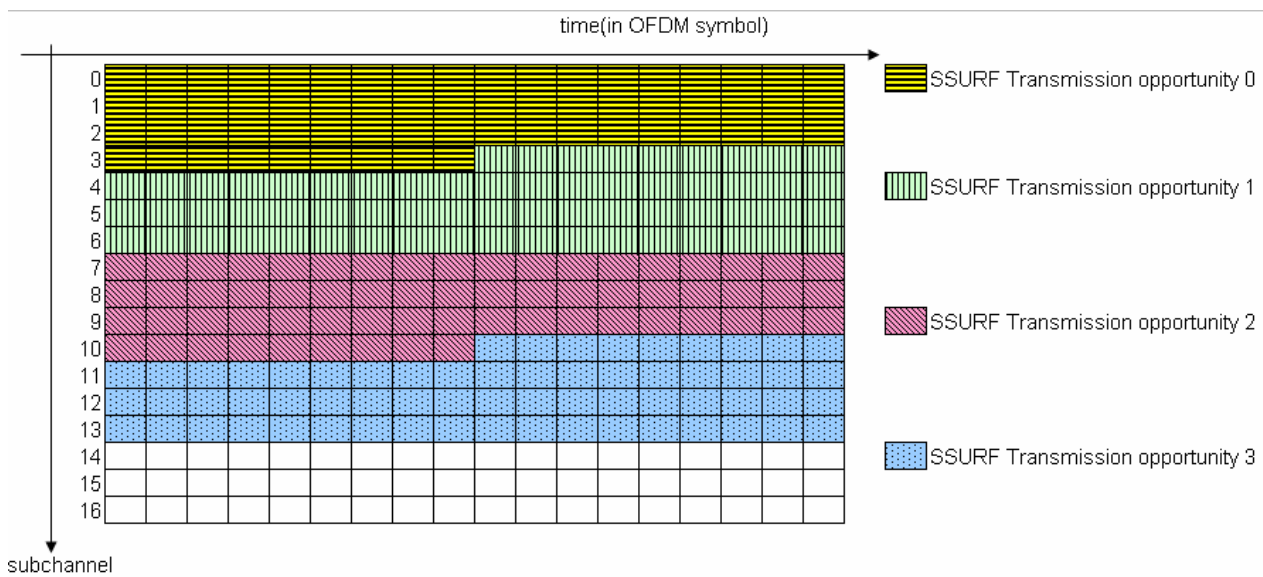

**Figure hxx SSURF transmission opportunity allocation map for WirelessMAN-OFDMA**

SSURF transmission opportunity IE in CX UL-MAP is used to SS during which SSURF transmission opportunity it will send SSURF message.

## Reference

- [1] C802.16h-07/106, Action Items from Session #52
- [2] 80216h-07/053r2, Comment database on 16h draft D3
- [3] C80216h-07/102, Ad hoc on CMI TX and RX