

Project	<b>IEEE 802.16 Broadband Wireless Access Working Group</b> < <a href="http://ieee802.org/16">http://ieee802.org/16</a> >	
Title	<b>Resource Request for Bandwidth</b>	
Date Submitted	<b>2007-01-15</b>	
Source(s)	<p>Yousuf Saifullah, Shashikant Maheshwari, Haihong Zheng Nokia 6000 Connection Drive, Irving, TX</p> <p>Masato Okuda Fujitsu Laboratories LTD. Kamikodanaka 4-1-1, Nakahara-ku Kawasaki, Japan. 211-8588</p> <p>Kerstin Johnsson, Jerry Sydir, Wendy Wong, Hannah Lee</p> <p>Intel Corp.  2200 Mission College Blvd.  Santa Clara, CA 95054</p> <p>Kanchei (Ken) Loa, Yi-Hsueh Tsai, Shiann-Tsong Sheu, Hua-Chiang Yin, Chih-Chiang Hsieh, Yung-Ting Lee, Frank C.D. Tsai, Heng-Iang Hsu, Youn-Tai Lee</p> <p>Institute for Information Industry  8F., No. 218, Sec. 2, Dunhua S. Rd.,  Taipei City, Taiwan.</p>	<p>voice: 972 894 5000 mailto: yousuf.saifullah@nokia.com shashikant.maheshwari@nokia.com haihong.1.zheng@nokia.com</p> <p>voice: +81-44-754-2811 fax: +81-44-754-2786 mailto: okuda@jp.fujitsu.com</p> <p>voice: +1-408-653-9651 mailto: kerstin.johnsson@intel.com</p> <p>Voice: +886-2-2739-9616 mailto: <a href="mailto:loa@iii.org.tw">loa@iii.org.tw</a></p>
Re:	This is a response to the call for proposals 80216j-06_034.pdf .	
Abstract	This contribution proposes a mechanism for requesting bandwidth allocation.	
Purpose	Add proposed spec changes in P802.16j Baseline Document (IEEE 802.16j-06/026)	
Notice	This document has been prepared to assist IEEE 802.16. It is offered as a basis for discussion and is not binding on the contributing individual(s) or organization(s). The material in this document is subject to change in form and content after further study. The contributor(s) reserve(s) the right to add, amend or withdraw material contained herein.	

---

Release	The contributor grants a free, irrevocable license to the IEEE to incorporate material contained in this contribution, and any modifications thereof, in the creation of an IEEE Standards publication; to copyright in the IEEE's name any IEEE Standards publication even though it may include portions of this contribution; and at the IEEE's sole discretion to permit others to reproduce in whole or in part the resulting IEEE Standards publication. The contributor also acknowledges and accepts that this contribution may be made public by IEEE 802.16.
Patent Policy and Procedures	The contributor is familiar with the IEEE 802.16 Patent Policy and Procedures < <a href="http://iee802.org/16/ipr/patents/policy.html">http://iee802.org/16/ipr/patents/policy.html</a> >, including the statement "IEEE standards may include the known use of patent(s), including patent applications, provided the IEEE receives assurance from the patent holder or applicant with respect to patents essential for compliance with both mandatory and optional portions of the standard." Early disclosure to the Working Group of patent information that might be relevant to the standard is essential to reduce the possibility for delays in the development process and increase the likelihood that the draft publication will be approved for publication. Please notify the Chair < <a href="mailto:chair@wirelessman.org">mailto:chair@wirelessman.org</a> > as early as possible, in written or electronic form, if patented technology (or technology under patent application) might be incorporated into a draft standard being developed within the IEEE 802.16 Working Group. The Chair will disclose this notification via the IEEE 802.16 web site < <a href="http://iee802.org/16/ipr/patents/notices">http://iee802.org/16/ipr/patents/notices</a> >.

---

## Resource Request for Bandwidth and Ranging

*Yousuf Saifullah, Shashikant Maheshwari, Haihong Zheng*

*Masato Okuda*

*Kerstin Johnsson, Jerry Sydir, Wendy Wong, Hannah Lee*

*Kanchei (Ken) Loa, Yi-Hsueh Tsai, Shiann-Tsong Sheu, Hua-Chiang Yin, Chih-Chiang Hsieh, Yung-Ting Lee, Frank C.D. Tsai, Heng-lang Hsu, Youn-Tai Lee*

### Introduction

In systems with fully centralized control, the MR-BS allocates MAPs for relay and access links in its MR-cell. Any bandwidth request originating at an MS needs to go to the MR-BS, so it can perform UL allocation on the relay and access links along the MS's path to the MR-BS.

Without relay, an MS can send a CDMA code directly to the BS to indicate that it needs an allocation on which to forward a bandwidth request to the BS. If this code is successfully detected, the BS inserts a CDMA\_Allocation\_IE into the UL-MAP that it transmits to the MS indicating where/when the MS can transmit its BW request to the BS. These transmissions and allocations reside exclusively on the link between the BS and MS. This process is depicted in Figure A-1.

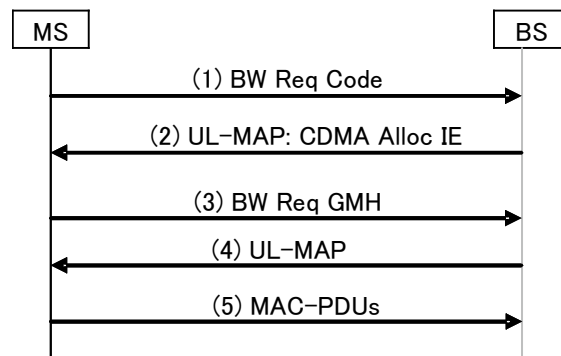

Figure A-1 BW request/allocation in 802.16e systems using CDMA ranging codes

With relay, the CDMA ranging code does not reach the MR-BS in one hop. More importantly, since the MR-BS creates a CDMA\_Allocation\_IE based on both the code it receives and the transmit region of this code, simply forwarding this code along each hop would not result in an accurate CDMA\_Allocation\_IE. Instead the code as well as its original transmit region would need to be encapsulated into a new message and forwarded to the MR-BS.

Unfortunately, as Figure A-2 shows, forwarding this message to the MR-BS requires initiating yet another contention-based bandwidth request process, this time from the next station along the path (in this case the RS). Moreover, as Figure A-2 shows, more contention-based bandwidth request processes would need to be initiated to complete the forwarding of both the BW request and the data sent by the MS. The conclusion is that if a relay system implements the bandwidth request and allocation scheme as specified in [2][3], it will introduce a large amount of overhead and latency.

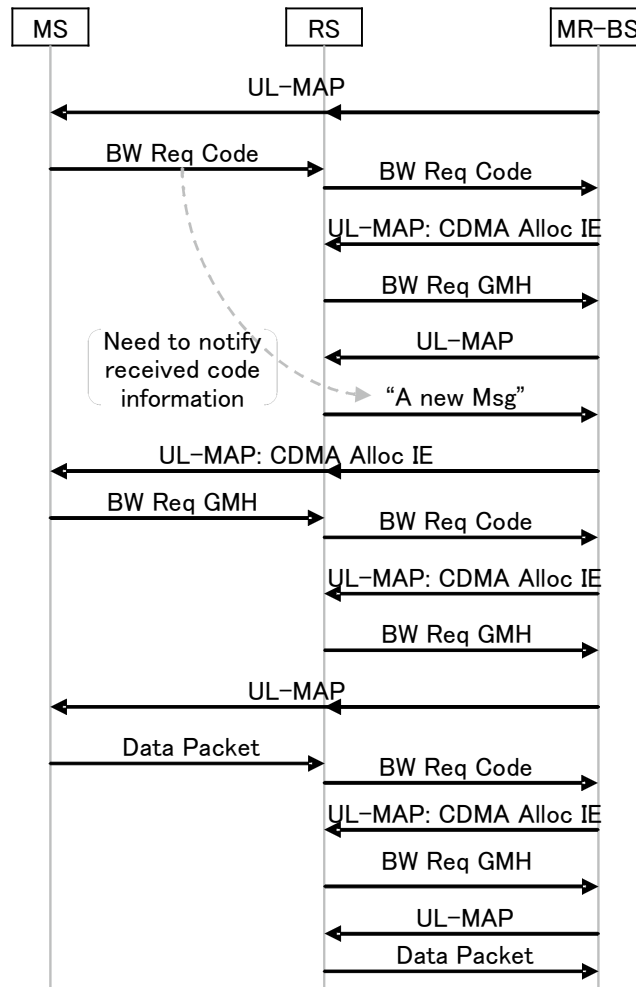

Figure A-2 BW request/allocation in relay systems based on 802.16e protocols

### Proposal

This contribution proposes that each RS in the system be assigned a distinct RS CDMA ranging code during its initial ranging for the specific purpose of supporting the BW request process. This RS CDMA ranging code would work as follows. When an MS transmits a ranging code to its access RS for the purpose of acquiring bandwidth on which to forward a BW request and this code is successfully detected, the access RS forwards its assigned RS CDMA ranging code to the MR-BS (note: when RSs along the path to the MR-BS receive an RS CDMA ranging code, they simply forward it upstream; since RS CDMA ranging codes will belong to a distinct set, all RSs will be able to distinguish between RS ranging codes and other ranging codes). Receipt of this RS CDMA ranging code informs the MR-BS that it needs to create uplink allocations on the access link to that RS as well as the relay links that make up the path from the RS to the MR-BS. The MR-BS has knowledge of the links that make up this path via route discovery procedures such as in [1].

A similar procedure can be used for other CDMA ranging code procedures such as initial ranging and periodic ranging. Moreover, it is the same regardless of the type of RS (i.e. fixed, nomadic, or mobile) or the number of hops in the path. It is completely transparent to existing procedures performed by the MS and therefore requires no changes to the MS.

Figure A-3 shows an example of bandwidth request and allocation signaling using the proposed scheme.

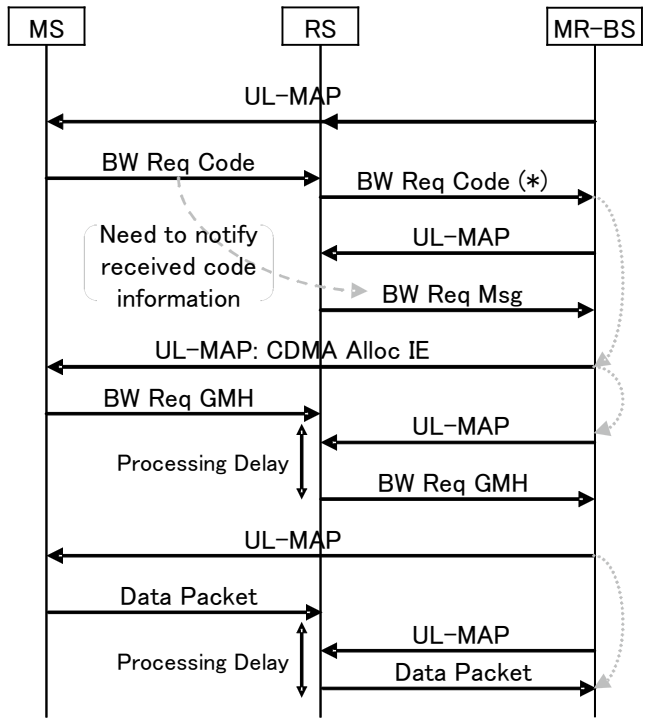

Figure A-3 BW request/allocation signaling using proposed schemes

## Specification changes

*[Insert the following new subclause at the end of 6.3.2.3:]*

### 6.3.2.3.x MR\_Code-REP message

This message is used by an RS to notify the MR-BS that it has successfully received CDMA ranging codes. This message is transmitted using the RS's basic CID. See 11.X for MR\_CODE-REP TLV

Table xx MR Code Report (MR\_CODE-REP) message Format

Syntax	Size	Note
MR_Code_Report_format() {		
Management Message Type = xx	8 bits	TBA
MR_CODE-REP TLVs	Variable	
}		

*[Insert the following new section at the end of 6.3.6:]*

### 6.3.6.7 Relay bandwidth request and allocation mechanisms

In all bandwidth request and allocation mechanisms, the SS shall use the same CDMA bandwidth request procedure as specified in 6.3.6.5

#### 6.3.6.7.1 Distributed bandwidth request and allocation

*[This subclause is just a place holder. The contents are in a different contribution.]*

#### 6.3.6.7.2 Centralized bandwidth request and allocation

In systems with centralized bandwidth allocation, the MR-BS shall determine the bandwidth allocations for all links (access and relay) in its MR-cell. Thus, before a station can transmit a packet to the MR-BS, that station's bandwidth request must first reach the MR-BS, which then creates bandwidth allocations on the links along the path from the station to the MR-BS.

##### 6.3.6.7.2.1 Contention-based CDMA Bandwidth Requests for Relay

The MR-BS shall assign unique RS CDMA ranging codes to each RS in its MR-cell in order to reduce the overhead and latency of various ranging processes in relay networks with centralized control (see subclause 6.3.10.3.x). RS CDMA ranging codes are assigned to an RS during its initial ranging process by sending an RS\_CDMA\_Codes TLV in the RNG-RSP.

A set of these RS CDMA ranging codes may be reserved for the purpose of informing the MR-BS that an SS attached to the originating RS is requesting to forward a BW request header to the MR-BS. When the MR-BS receives such a code, it shall create BW allocations on the access link and the relay links along the path to the MR-BS for the purpose of forwarding a BW request header from the SS to the MR-BS. This requires that the MR-BS not only know the path from the RS but also the processing time at each RS in the MR-cell.

Thus, when an RS receives a BW request CDMA ranging code from one of its SSs, it shall send the appropriate RS CDMA ranging code toward the MR-BS indicating that one of its SSs is requesting to forward a BW request

header to the MR-BS. Each intermediate RS along the path to the MR-BS relays this code in the uplink direction. Upon receiving this code, the MR-BS shall respond by creating the appropriate downlink and uplink allocations.

Another set of RS CDMA ranging codes may be reserved for the purpose of informing the MR-BS that the originating RS is requesting to forward a BW request header to the MR-BS. Although RSs do not create data traffic, they may need to request bandwidth for management messages or for queued SS data if previous BW allocations did not suffice due to unsuccessful transmissions, changes in modulation/coding rate, etc. The MR-BS responds to this type of code in a manner similar to the one described above except that there is not access uplink allocation.

#### **6.3.6.7.2.2 Continuous bandwidth allocation mechanism**

MR-BSs and RSs shall support the continuous bandwidth allocation mechanism specified in this subclause. When an MR-BS allocates bandwidth to forward a packet to/from a given station, it shall allocate bandwidth on all links (relay and access) that make up the path to/from that station taking into account the processing delay at each RS along the path as well as the multi-hop frame structure.

To create this continuous forwarding of a packet, the MR-BS shall allocate bandwidth on consecutive links along a path by creating an allocation for the second link at the first opportunity **after** the allocation of the first link plus the intermediate station's processing time. Each RS's uplink processing delay is notified to the MR-BS using the SBC-REQ message during the RS's network entry process.

*[Insert the following new subclause at the end of 6.3.10.3:]*

#### **6.3.10.3.x Ranging in relay networks with centralized bandwidth allocation**

In relay networks with centralized bandwidth allocation, the MR-BS shall assign unique CDMA ranging codes to each RS in its MR-cell so that it can immediately determine the purpose and the originator of the code. These codes allow the RS to quickly inform the MR-BS that it is engaged in a ranging process with one of its downstream stations and receive bandwidth from the MR-BS on which to continue or complete the process.

The RS may be assigned several unique CDMA ranging codes for the purpose of supporting various ranging processes. The codes that may be assigned to the RS to communicate different requests to the MR-BS are:

- 1) Indicate that the RS needs BW on its access downlink on which to transmit a RNG-RSP message with "continue" status
- 2) Indicate that the RS needs BW on its *access* downlink on which to transmit a RNG-RSP message with "success" status as well as BW allocations on its access uplink and the relay uplinks along the path to the MR-BS on which to forward a RNG-REQ
- 3) Indicate that the RS needs BW allocations on its access uplink and the relay uplinks along the path to the MR-BS on which to forward a BW request header
- 4) Indicate that the RS needs BW on its *relay* downlink (i.e. to its downstream RS) on which to transmit a RNG-RSP message with "continue" status
- 5) Indicate that the RS needs BW on its relay downlink on which to transmit a RNG-RSP message with "success" status as well as BW allocations on its relay uplink (i.e. from its downstream RS) and the relay uplinks along the path to the MR-BS on which to forward a RNG-REQ.
- 6) Indicate that the RS needs BW allocations on the relay uplinks along the path to the MR-BS on which to forward a BW request header.

**6.3.2.3.5 Ranging request (RNG-REQ) message***[Add the following text to the end of subclause 6.3.2.3.5:]*

The following parameter may be included in the RNG-REQ message when the RS is attempting to perform network entry, re-entry, association or handover:

**RS Type TLV (see 11.5)****6.3.2.3.6 Ranging Response (RNG\_RSP) message***[Add the following text to the end of subclause 6.3.2.3.6:]*

The following parameter may be included in the RNG-RSP message for the purpose of assigning RS CDMA ranging codes to an RS:

**RS CDMA Codes TLV (see 11.19)****11.5 RNG-REQ message encoding***[Add the following row to Table 364:]*

Name	Type (1 byte)	Length	Value (variable-length)
RS Type	-	1	0: Fixed RS 1: Mobile RS 2-255: Reserved

**11.6 RNG-RSP management message encodings***[Insert new subclause 11.6.2:]***11.19.1 RS CDMA Codes TLV**

Name	Type (1 byte)	Length	Value
RS CDMA Code	-	6	The TLV carries 1 byte ranging code in the following order <ul style="list-style-type: none"> <li>- Ranging Request for SS (Continue)</li> <li>- Ranging Request for SS (Success)</li> <li>- Bandwidth Request for SS</li> <li>- Ranging Request for RS (Continue)</li> <li>- Ranging Request for RS (Success)</li> <li>- Bandwidth Request for RS</li> </ul>

*[Insert new subclause 11.X:]***11.X MR Code Report management message encodings**



Name	Type	Length	Value
Code attributes	TBA	4	<p>Bits 31:22 – Used to indicate the OFDM time symbol reference that was used to transmit the ranging code.</p> <p>Bits 21:16 – Used to indicate the OFDMA subchannel reference that was used to transmit the ranging code.</p> <p>Bits 15:8 – Used to indicate the ranging code index that was sent by the SS or RS.</p> <p>Bits 7:0 – The 8 least significant bits of the frame number of the OFDMA frame where the SS sent the ranging code.</p>

## References

- [1] Haihong Zheng, Yousuf Saifullah, Shashikant Maheshwari, Nokia , “Topology Discovery and Path Management in multi-hop relay System”, IEEE C80216j-06\_195.doc
- [2] IEEE 802.16-2004 Part 16: Air Interface for Fixed Broadband Wireless Access Systems
- [3] IEEE 802.16e-2005 Part 16: Air Interface for Fixed and Mobile Broadband Wireless Access Systems Amendment 2: Physical and Medium Access Control Layers for Combined Fixed and Mobile Opera