

Project	IEEE 802.16 Broadband Wireless Access Working Group < <a href="http://ieee802.org/16">http://ieee802.org/16</a> >	
Title	<b>MS MAC Handover Procedure in an MR Network-Termination</b>	
Date Submitted	2007-01-08	
Source(s)	<p>Hyunjeong Lee  <a href="mailto:Hyunjeong.hannah.lee@intel.com">Hyunjeong.hannah.lee@intel.com</a>  Wendy C. Wong  Jerry Sydir  Kerstin Johnsson  Intel Corporation  2111 NE 25<sup>th</sup> Ave  Hillsboro, OR 97124</p> <p>Sujean Yang <a href="mailto:sujean35@ewhain.net">sujean35@ewhain.net</a>  Meejeong Lee <a href="mailto:lmj@ewha.ac.kr">lmj@ewha.ac.kr</a>  Dept. of Computer Science and Engineering  Ewha Womans University, Seoul, Korea</p>	<p>Hyunjeong Kang  <a href="mailto:Hyunjeong.kang@samsung.com">Hyunjeong.kang@samsung.com</a>  Sungjin Lee  Hyoung Kyu Lim  Jungje Son  Samsung Electronics  416, Maetan-3dong, Youngtong-gu,  Suwon-si, Gyeonggi-do, Korea</p> <p>Rakesh Taori  Samsung Advanced Institute of Technology</p>
Re:	Submitted in response to Call for technical proposals issued by IEEE 802.16j on 2006-12-12	
Abstract	This document proposes termination and other miscellaneous procedures related to MSs in IEEE 802.16j networks where both MR-BS and its subordinate RSs in an MR-cell transmit their own broadcast control message such as preamble, FCH, DCD, UCD, DL-MAP and UL-MAP.	
Purpose	This contribution is provided as input for the IEEE 802.16j amendment.	
Notice	This document has been prepared to assist IEEE 802.16. It is offered as a basis for discussion and is not binding on the contributing individual(s) or organization(s). The material in this document is subject to change in form and content after further study. The contributor(s) reserve(s) the right to add, amend or withdraw material contained herein.	
Release	The contributor grants a free, irrevocable license to the IEEE to incorporate material contained in this contribution, and any modifications thereof, in the creation of an IEEE Standards publication; to copyright in the IEEE's name any IEEE Standards publication even though it may include portions of this contribution; and at the IEEE's sole discretion to permit others to reproduce in whole or in part the resulting IEEE Standards publication. The contributor also acknowledges and accepts that this contribution may be made public by IEEE 802.16.	
Patent Policy and Procedures	The contributor is familiar with the IEEE 802.16 Patent Policy and Procedures < <a href="http://ieee802.org/16/ipr/patents/policy.html">http://ieee802.org/16/ipr/patents/policy.html</a> >, including the statement "IEEE standards may include the known use of patent(s), including patent applications, provided the IEEE receives assurance from the patent holder or applicant with respect to patents essential for compliance with both mandatory and optional portions of the standard." Early disclosure to the Working Group of patent information that might be relevant to the standard is essential to reduce the possibility for delays in the development process and increase the likelihood that the draft publication will be approved for publication. Please notify the Chair < <a href="mailto:chair@wirelessman.org">mailto:chair@wirelessman.org</a> > as early as possible, in written or electronic form, if patented technology (or technology under patent application) might be incorporated into a draft standard being developed within the IEEE 802.16 Working Group. The Chair will disclose this notification via the IEEE 802.16 web site < <a href="http://ieee802.org/16/ipr/patents/notices">http://ieee802.org/16/ipr/patents/notices</a> >.	

## 1. Introduction

The proposed MAC handover scheme will enable an 802.16e compliant MS to handover seamlessly in an MR network following the MAC handover procedure defined in subclause 6.3.22 of IEEE 802.16e-2005. This contribution proposes additions/modifications to handover termination and other miscellaneous processes defined in subclauses 6.3.22.2.3, 6.3.22.2.5, and 6.3.22.2.6 of IEEE 802.16e-2005.

Figure 1 depicts the seven handover cases that are covered in this contribution. Please refer to Sections 1.1 of [1] for terminologies used in this contribution.

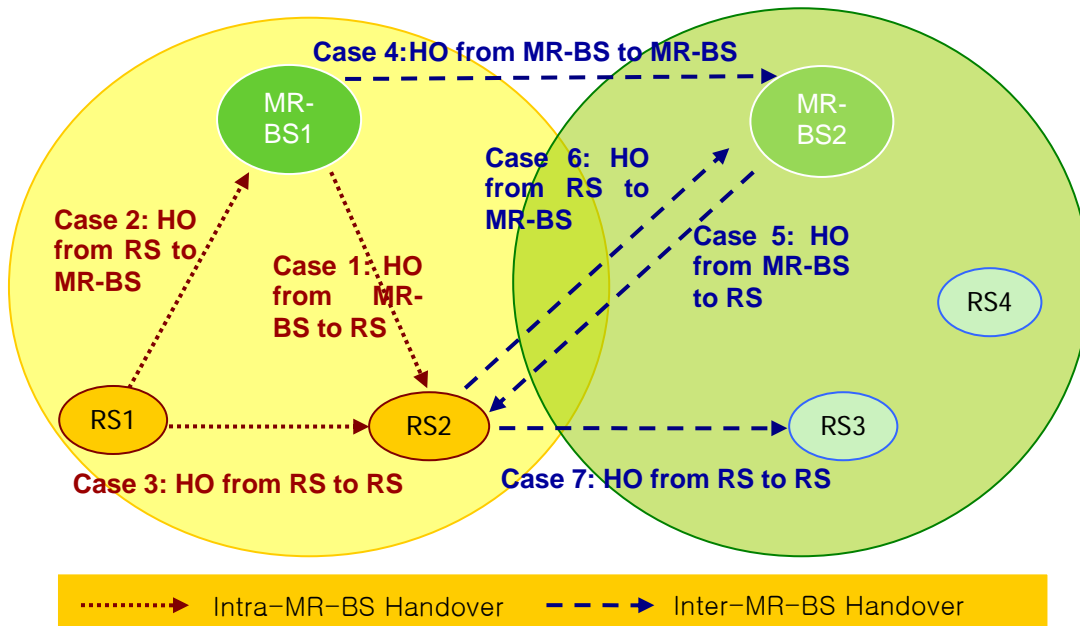

Figure 1. Seven Handover Cases in an MR network

## 2. Termination and other miscellaneous procedures related to MS handover

### 2.1 Handover Termination

During the handover process, the MS sends its current access station a MOB\_HO-IND (HO\_IND\_type = 0b00) to release it. This message contains a *Target BS\_ID* field which indicates the target access station.

The detailed termination processes are described in Table 1 (a) and (b). In IEEE 802.16e-2005, the successful MS network attachment at the target BS is informed to the old serving BS over the backbone. Similarly, we propose a new MAC management message *HO\_CPL*. This message is used to inform the successful MS network attachment at a target access station over the relay links.

Figure 2 shows an example of signaling in relation to MOB\_HO-IND and HO\_CPL for six cases of Figure 1 (except Case 4). Case 4 is not included because it exactly follows the 802.16e procedure.

**Table 1. Termination  
(a) after Intra MR-BS handover**

New Access Old Access	MR-BS in the same MR cell	RS in the same MR cell
MR-BS	N/A	<p>(1) When receiving a MOB_HO-IND message, the MR-BS shall keep the MS context information as the serving MR-BS.</p> <p>(2) As the handover completes at the new access RS, it transmits a <i>HO_CPL</i> message to the old access MR-BS to inform the handover completion.</p>
RS	<p>(1) A MOB_HO-IND message is relayed to the serving MR-BS.</p> <p>(2) The old access RS may start its Resource_Retain_Time timer.</p> <p>(3) As the handover completes at the new access station, i.e., the serving MR-BS, it issues the <i>HO_CPL</i> message to the old access RS over the relay links.</p> <p>(4) Upon expiration of Resource_Retain_Time timer or receiving a <i>HO_CPL</i> message, the old access RS shall remove all the MS context information.</p> <p>(5) Resource release along the old path may be initiated either by the MR-BS or by the old access RS.</p>	<p>(1) A MOB_HO-IND message is relayed to the serving MR-BS.</p> <p>(2) The old access RS may start its Resource_Retain_Time timer.</p> <p>(3) At the handover completion, the new access RS informs the serving MR-BS and/or the old access RS of the handover completion by transmitting a <i>HO_CPL</i> message. If a 1-hop relay link exists between the old access RS and the new access RS, a <i>HO_CPL</i> message may be transmitted directly from the new to the old access station. Otherwise, the serving MR-BS transmits to the old access RS the <i>HO_CPL</i> message received from the new access RS.</p> <p>(4) Upon expiration of Resource_Retain_Time timer or receiving a <i>HO_CPL</i> message, the old access RS shall remove all the MS context information.</p> <p>(5) Resource release along the old path may be initiated either by the MR-BS or by the old access RS.</p>

**(b) after Inter MR-BS handover**

New Access Old Access	MR-BS in a different MR cell	RS in a different MR cell
MR-BS	Follows the procedure as defined in IEEE 802.16e-2005	<p>(1) Upon receiving a MOB-HO_IND message, the old access MR-BS starts Resource_Retain_Time timer.</p> <p>(2) At the handover completion, the new access RS transmits a <i>HO_CPL</i> message to the new serving MR-BS to inform the handover completion.</p>

		<p>(3) The new serving MR-BS sends a backbone message to the old serving MR-BS indicating successful MS network attachment at the target access station.</p> <p>(4) Upon expiration of Resource_Retain_Time timer or receiving the backbone message, the old access MR-BS shall remove all the MS context information and release the resource assigned to the MS.</p>
RS	<p>(1) A MOB_HO-IND message is relayed to the old serving MR-BS.</p> <p>(2) The old serving MR-BS shall start Resource_Retain_Time timer upon receiving the MOB_HO-IND message. The old access RS may start Resource_Retain_Time timer upon receiving the MOB_HO-IND message.</p> <p>(3) At the HO completion, the new access MR-BS sends a backbone message to the old serving MR-BS indicating successful MS network attachment at the target access station.</p> <p>(4) Upon receiving the backbone message, the old MR-BS issues a <i>HO_CPL</i> message to the old access RS to inform the handover completion.</p> <p>(5) Upon expiration of Resource_Retain_Time timer or receiving a <i>HO_CPL</i> message, the old access RS and old serving MR-BS shall remove MS context information and release resource.</p> <p>(6) Resource release along the old path may be initiated either by the MR-BS or by the old access RS.</p>	<p>(1) A MOB_HO-IND message is relayed to the old serving MR-BS.</p> <p>(2) The old serving MR-BS shall start Resource_Retain_Time timer upon receiving a MOB_HO-IND message. The old access RS may start Resource_Retain_Time timer upon receiving a MOB_HO-IND message.</p> <p>(3) At the handover completion, the new access RS transmits a <i>HO_CPL</i> message to the new serving MR-BS indicating successful MS network attachment at the target access station.</p> <p>(4) Then, the new serving MR-BS sends a backbone message to the old serving MR-BS indicating successful MS network attachment at the target access station. Upon receiving the backbone message, the old serving MR-BS issues a <i>HO_CPL</i> message to the old access RS.</p> <p>(5) Upon expiration of Resource_Retain_Time timer or receiving a <i>HO_CPL</i> message, the old access RS and old serving MR-BS shall remove MS context information and release resource.</p> <p>(6) Resource release along the old path may be initiated either by the MR-BS or by the old access RS.</p>

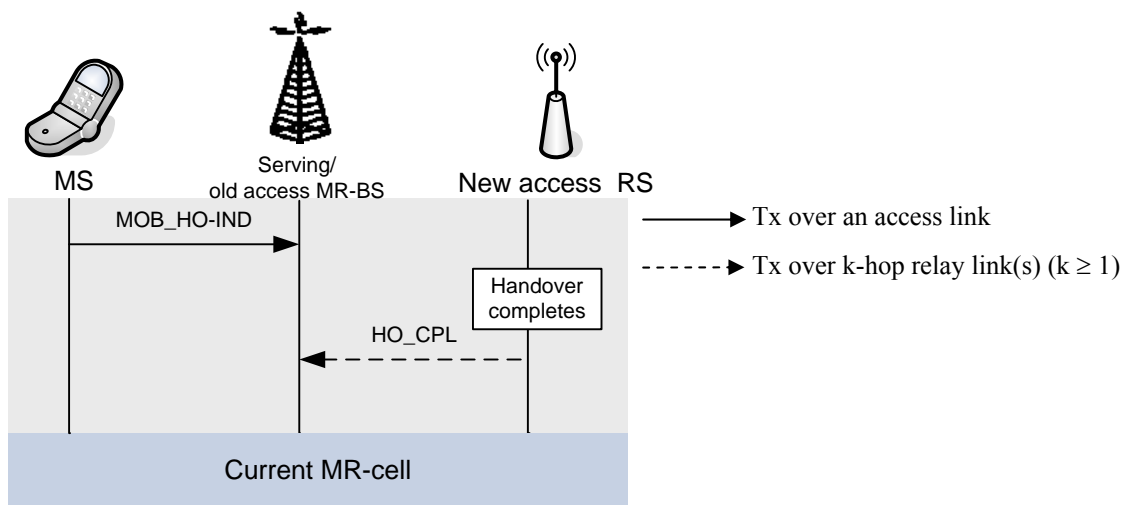

(a) Case 1: The old access station is an MR-BS and the new access station is an RS in the same MR cell

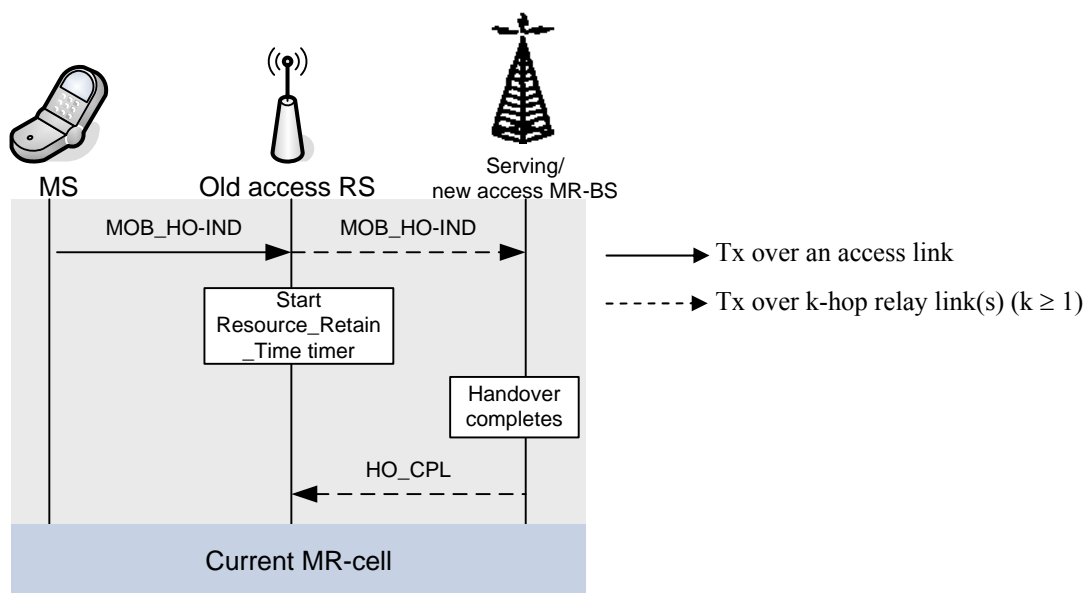

(b) Case 2: The old access station is an RS and the new access station is a serving MR-BS

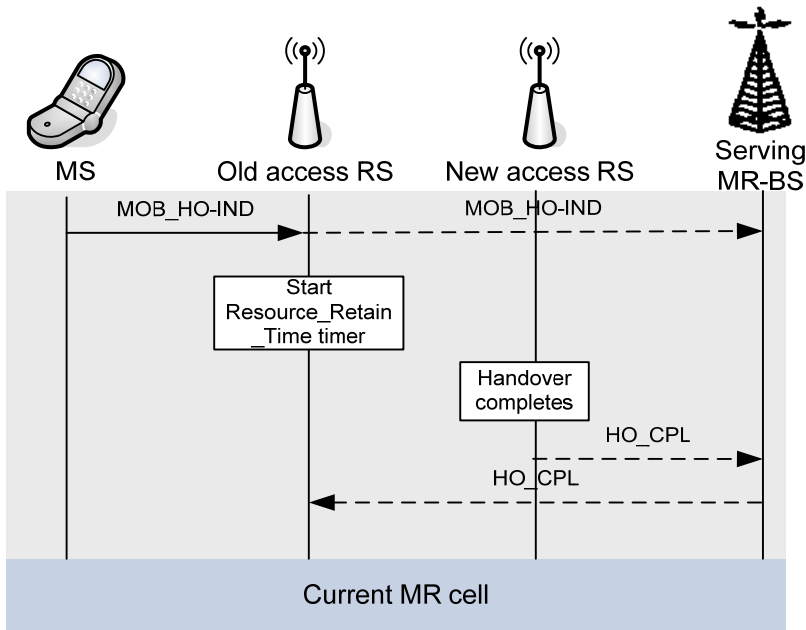

—————> Tx over an access link  
 - - - - -> Tx over k-hop relay link(s) ( $k \geq 1$ )

(c) Case3: The old access station is an RS and the new access station is another RS in the same MR cell. This flow is an example when a direct 1-hop relay link doesn't exist between the current and the target access RSs.

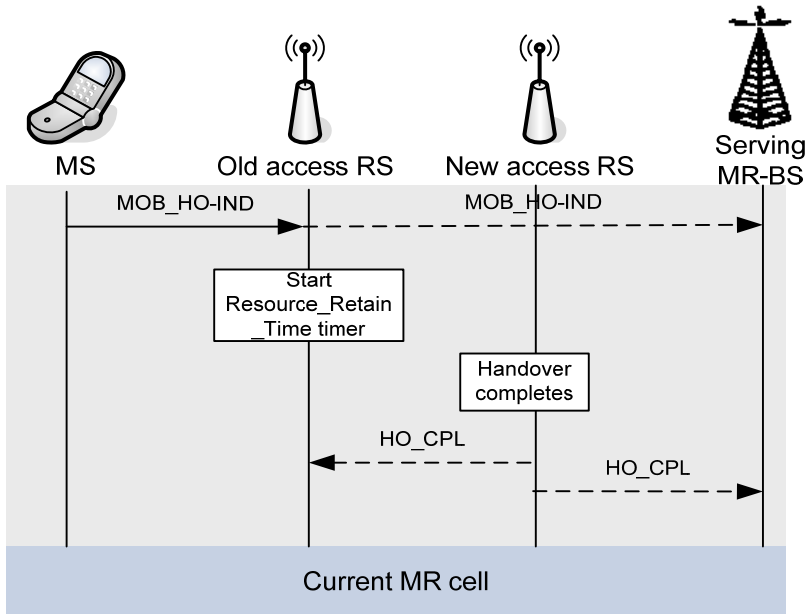

—————> Tx over an access link  
 - - - - -> Tx over k-hop relay link(s) ( $k \geq 1$ )

(d) Case3: The old access station is an RS and the new access station is another RS in the same MR cell. This flow is an example when a direct 1-hop relay link exists between the current and the target access RSs.

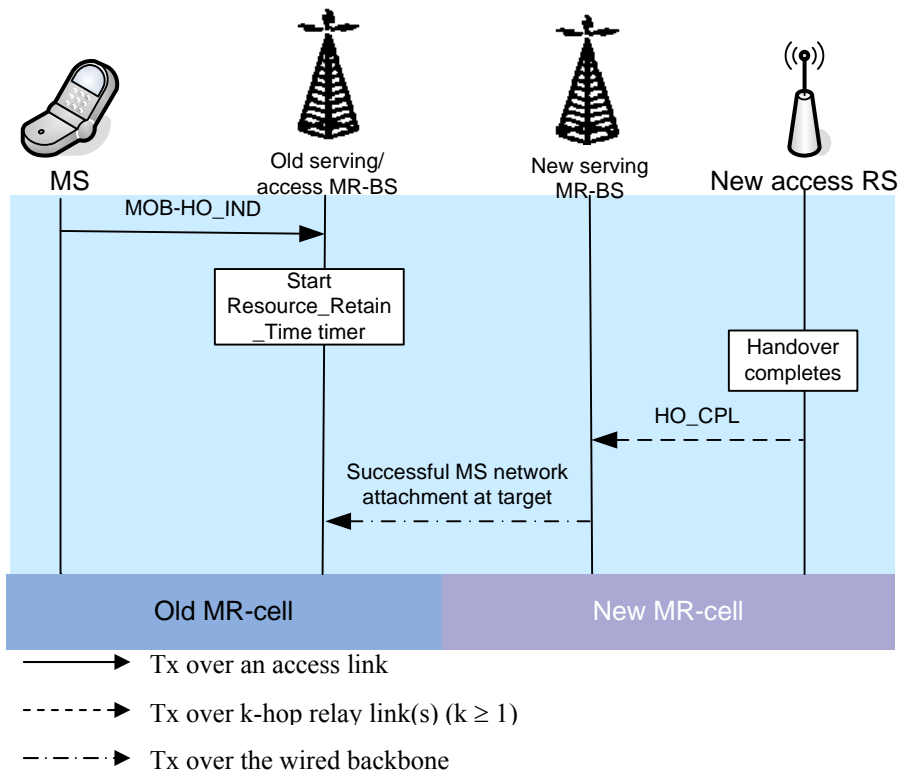

(e) Case 5: The old access station is an MR-BS and the new access station is an RS in a different MR cell

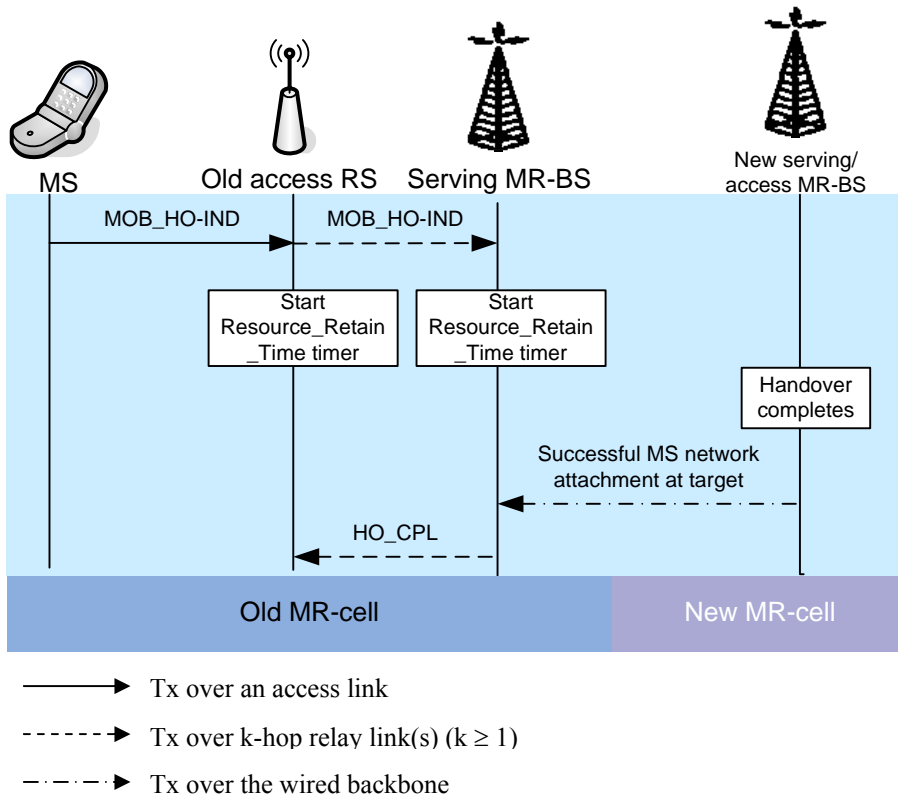

(f) Case 6: The old access station is an RS and the new access station is an MR-BS in a different MR cell

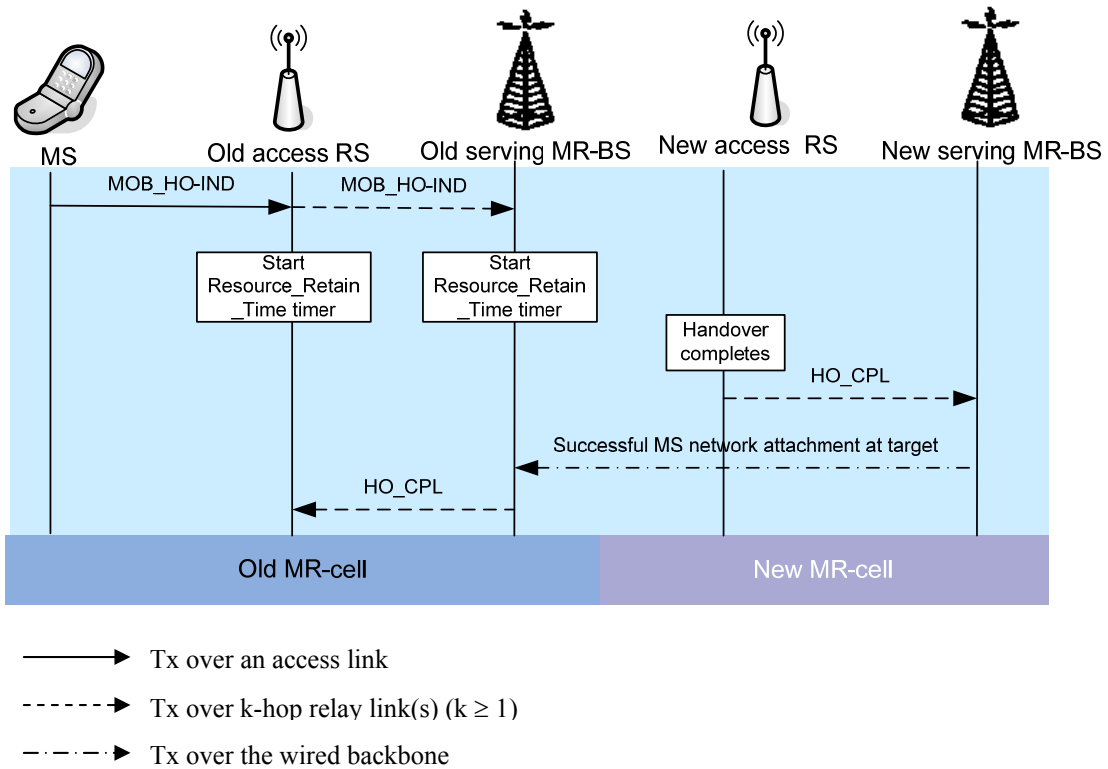

(g) Case 7: The old access station is an RS and the new access station is another RS in a different MR cell.

Figure 2. An example of signaling message exchanges for termination. (Other flows are possible for each case)

### 2.2 Drop

When a drop is detected by an MS, the MS follows the procedure defined in 6.3.22.2.6 of IEEE 802.16e-2005.

If the access station is an RS and it detects a drop, the access station reacts as if it receives MOB\_HO-IND with BS release (HO\_IND\_type = 0b00).

### 3. Proposed text

*[Insert the following at the end of subclause 6.3.22.2.5]*

Upon receiving a MOB\_HO-IND message with HO\_IND\_type = 0b00 from an MS, the old access RS shall relay it to the old serving MR-BS and may start its Resource\_Retain\_Time timer. Upon expiration of Resource\_Retain\_Time timer or receiving the successful MS network attachment, the old access RS shall remove all the MS context information. An old serving MR-BS can receive a MOB\_HO-IND message directly from an MS or a relayed one from its subordinate RS. When an MR-BS receives a MOB\_HO-IND message, the MR-BS shall start Resource\_Retain\_Time timer in the case that a target access station in the MOB\_HO-IND message is not managed by the MR-BS.

The successful MS network attachment at a target access station is informed to the old access



station and/or old serving station and/or target serving station by transmitting HO\_CPL message over the relay links.

[Insert the following at the end of subclause 6.3.22.2.6]

If the access station is an RS and it detects a drop, the access station reacts as if it receives MOB\_HO-IND with BS release (HO\_IND\_type = 0b00).

[Insert the following as a new subclause 6.3.2.3.xx]

### **6.3.2.3.XX HO-CPL**

This message is to inform MS's network attachment at a target access station.

<u>Syntax</u>	<u>Size (bits)</u>	<u>Notes</u>
<u>HO_CPL_Message_format() {</u>		
<u>Management_Message_Type = TBD</u>	<u>TBD</u>	
<u>MS_ID</u>	<u>48</u>	
<u>}</u>		

## **Annex I**

(informative)

### **MAC management message flow related to handover in MR networks**

#### I.XX HO\_CPL message flow related to handover completion

As the handover completes at a new access station, a HO\_CPL message is delivered following the procedure below:

- Intra MR-BS handover
  - o If the old access station is an MR-BS and the new access station is an RS (or vice versa), the new access station transmits HO\_CPL to the old access station to inform the handover completion.
  - o If both old and new access stations are RSs, the new access RS transmits HO\_CPL to the serving MR-BS to inform the handover completion. If a 1-hop relay link exists between the old access RS and the new access RS, HO\_CPL may be transmitted directly from the new to the old access station. Otherwise, the serving MR-BS transmits to the old access RS the HO\_CPL message received from the new access RS.
- Inter MR-BS handover
  - o If the new access station is an RS, it transmits a HO\_CPL message to the new serving MR-BS.
  - o Upon receiving the new HO\_CPL message from a new access RS or if the MR-BS is a new access station, the MR-BS sends a backbone message to the old serving MR-BS indicating successful MS network attachment at the target access station.
  - o If an MR-BS receives a backbone message indicating successful MS network attachment at the target access station and the old access station is its subordinate RS, it transmits a HO\_CPL message to the old access RS.

## **References**

[1] IEEE C802.16j-07/082, "Overview of the proposal for MS MAC handover procedure in an MR Network," Jan. 2007