

Project	<b>IEEE 802.16 Broadband Wireless Access Working Group</b> < <a href="http://ieee802.org/16">http://ieee802.org/16</a> >	
Title	<b>Routing with CID Encapsulation</b>	
Date Submitted	<b>2007-01-08</b>	
Source(s)	<p>Aik Chindapol Jimmy Chui Hui Zeng Siemens Corporate Research Princeton, NJ, USA</p> <p>Byung-Jae Kwak, Sungcheol Chang, Young-il Kim ETRI 161, Gajeong-Dong, Yuseong-Gu, Daejeon, Korea 305-350</p> <p>Kyu Ha Lee Samsung Thales San 14, Nongseo-Dong, Giheung-Gu, Yongin, Gyeonggi-Do, Korea 449-712</p>	<p>Voice: +1 609 734 3364 Fax: +1 609 734 6565 Email: <a href="mailto:aik.chindapol@siemens.com">aik.chindapol@siemens.com</a></p> <p>Voice: +82-42-860-6618 Fax: +82-42-861-1966 <a href="mailto:bjkwak@etri.re.kr">bjkwak@etri.re.kr</a></p> <p>Voice: +82-31-280-9917 Fax: +82-31-280-1562 <a href="mailto:kyuha.lee@samsung.com">kyuha.lee@samsung.com</a></p>
Re:	This is in response to the call for proposals 80216j-06_034.pdf	
Abstract	This document describes fast connection routing via CID encapsulation.	
Purpose	This contribution is provided as input for the IEEE 802.16j baseline document.	
Notice	This document has been prepared to assist IEEE 802.16. It is offered as a basis for discussion and is not binding on the contributing individual(s) or organization(s). The material in this document is subject to change in form and content after further study. The contributor(s) reserve(s) the right to add, amend or withdraw material contained herein.	
Release	The contributor grants a free, irrevocable license to the IEEE to incorporate material contained in this contribution, and any modifications thereof, in the creation of an IEEE Standards publication; to copyright in the IEEE's name any IEEE Standards publication even though it may include portions of this contribution; and at the IEEE's sole discretion to permit others to reproduce in whole or in part the resulting IEEE Standards publication. The contributor also acknowledges and accepts that this contribution may be made public by IEEE 802.16.	
Patent Policy and Procedures	The contributor is familiar with the IEEE 802.16 Patent Policy and Procedures < <a href="http://ieee802.org/16/ipr/patents/policy.html">http://ieee802.org/16/ipr/patents/policy.html</a> >, including the statement "IEEE standards may include the known use of patent(s), including patent applications, provided the IEEE receives assurance from the patent holder or applicant with respect to patents essential for compliance with both mandatory and optional portions of the standard." Early disclosure to the Working Group of patent information that might be relevant to the standard is essential to reduce the possibility for delays in the development process and increase the likelihood that the draft publication will be approved for publication. Please notify the Chair < <a href="mailto:chair@wirelessman.org">mailto:chair@wirelessman.org</a> > as early as possible, in written or electronic form, if patented technology (or technology under patent application) might be incorporated into a draft standard being developed within the IEEE 802.16 Working Group. The Chair will disclose this notification via the IEEE 802.16 web site < <a href="http://ieee802.org/16/ipr/patents/notices">http://ieee802.org/16/ipr/patents/notices</a> >.	

# Fast Connection Establishment and Maintenance with Relays

*Aik Chindapol, Jimmy Chui, Hui Zeng*

*Siemens*

## 1 Introduction

In 802.16e, each connection (both management and data) is identified by a Connection ID (CID). Connections are identified by a 16-bit CID [2]. At MS initialization, management connections (basic connection and primary management connection) are established. The basic connection is for short, time-urgent MAC management messages and the primary management connection is for longer, more delay tolerant MAC management messages. In addition, transport connections for downlink and uplink are established to transfer data flows. There is no routing required; data is transmitted solely between the BS and the MS.

In a centralized multi-hop relay system, the routing for each MS is decided by the BS. The routing path is based on a number of factors such as measured channel qualities, QoS of each connection, fairness, etc. Each RS must be informed of which packets to detect and forward in order to provide the correct route for the packets. For wireless mobile networks, however, the topology of the network and the channel conditions change rapidly. Therefore, creating the routing structure and maintaining it are quite challenging.

This contribution proposes to allow the encapsulation of CIDs for the relaying of packets, as in [1]. That is, if a packet is to be transmitted to an MS via an RS, the packet intended for the MS (with CID "A") becomes the payload of a second packet (with CID "B") intended for the RS. When the RS receives the data, it understands to only retransmit the embedded data, i.e. the original packet intended for the MS.



Figure 1: Example of a CID encapsulated packet

This procedure can be used as a quick method for relaying data. The example in this proposal is the use of CID encapsulation for fast route updating. If the routing path for a particular MS changes, it may be possible to perform a temporary route changes via encapsulation. Although encapsulation incurs additional overhead, it is a quicker method of changing routing path than using other methods due to the time required to transmit and acknowledge management messages.

The proposal for this implementation has the following advantages:

- Simplified operation of the relay
- Initiating encapsulation operation is time-efficient. It is made by the BS without RS/MS involvement.

## 2 General Description

In the legacy 802.16e standard, each management and data connection for a particular MS is assigned a connection ID (CID) by the BS. The DL-MAP contains information about the CIDs in each allocated burst. By decoding this DL-MAP, the MS can identify which bursts it should listen to. This functionality should not be changed with the addition of relays.

CID encapsulation is a simple concept where the packet for a target recipient is the payload for an intermediary node, as described above. Although RSs do not have data to transmit on its own, the base station assigns a

1 specific CID for each RS. When the intermediary node receives a packet whose CID belongs to itself, it strips  
 2 away the outermost-layered header, decodes and forwards the payload with the CID indicated for the next hop,  
 3 which itself is a packet for the next recipient. The allocation of each transmission is allocated by the BS using a  
 4 regular MAP structure. This procedure can be concatenated to have many outer layers. The number of layers  
 5 required is the number of hops (minus one) in the path from BS to MS. This procedure satisfies the requirement  
 6 of maintaining MS legacy operation.

### 7 3 CID Encapsulation

8 For this method, the BS may encapsulate the message with a CID intended for the RS. Once the RS decodes it,  
 9 it removes encapsulation information and only forwards the original message with a different CID. If the  
 10 transmission involves multiple hops, the message may have to be encapsulated many times.

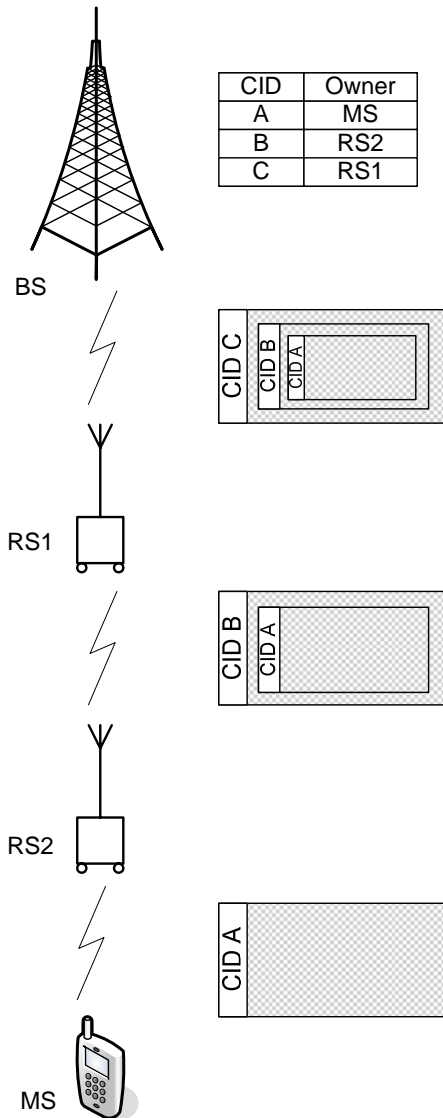

11  
 12 Figure 2 CID Encapsulation

13 Above is Figure 2 depicting encapsulation. The CIDs for the next hop are embedded in the data payload of the  
 14 current hop. There are no requirements for the relationship between the CID of the current packet and the  
 15 embedded CIDs. This allows fast route changes when data transfer is time-critical and there is not enough time  
 16 to perform proper route update.

It is also possible to have more than one embedded packet (multiple packets with multiple CIDs) in the packet containing encapsulated data.

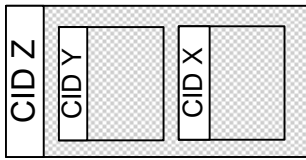

#### 4 Proposed Text

----- Beginning of Text Changes -----

--

##### 6.3.2.1 MAC header formats

[Change the text in Table 4 as indicated:]

**Table 4 – MAC header format**

Syntax	Size	Notes
MAC Header() {		
<b>HT</b>	1 bit	0 = Generic MAC header 1 = Bandwidth request header
<b>EC</b>	1 bit	If HT = 1, EC = 0
if (HT == 0) {		
<b>Type</b>	6 bits	
<b>CE</b>	1 bit	0 = no CID encapsulation 1 = CID encapsulation is in use
<b>CI</b>	1 bit	
<b>EKS</b>	2 bits	
<i>Reserved</i>	1 bit	Shall be set to zero
<b>LEN</b>	11 bits	
}		
else {		
<b>Type</b>	3 bits	
<b>BR</b>	19 bits	
}		
<b>CID</b>	16 bits	
<b>HCS</b>	8 bits	
}		

[Add the following text to 6.3.25]

### 6.3.25 Relay path management and routing

When a relay station receives a MAC PDU with the CE field set in the MAC header, it shall remove the current MAC header and forward the payload as the new PDU. If CRC is used, the BS calculates the CRC for each packet. This reduces the calculation required at each intermediary node.

----- End of Text Changes -----

## 5 References

- [1] IEEE C802.16j-06/004r1, "Recommendations on IEEE 802.16j".
- [2] IEEE 802.16-2004, "Part 16: Air Interface for Fixed and Mobile Broadband Wireless Access Systems".
- [3] IEEE 802.16e-2005, "Part 16: Air Interface for Fixed and Mobile Broadband Wireless Access Systems, Amendment 2: Physical and Medium Access Control Layers for Combined Fixed and Mobile Operation in Licensed Bands *and* Corrigendum 1".