IEEE 802.16 Broadband Wireless Access Working Group <<http://ieee802.org/16>>

Title **Comments on Frame Structure for multi-hop relay**

Date Submitted **2007-1-18**

Source(s)	Changyoon Oh, Youngbin Chang, Mihyun Lee, HyoungKyu Lim, Jaeweon Cho, Panyuh Joo Samsung Electronics 416, Maetan-3dong, Youngtong-gu, Suwon-si, Gyeonggi-do, Korea	Voice: +82-31-279-7529 Fax: +82-31-279-5130 mail to: changyoon.oh@samsung.com
------------------	---	---

Rakesh Taori
Samsung Advanced Institute of
Technology

Re: Response to call for technical contributions on 80216j-06_027, "Call for Technical Proposals regarding IEEE Project P802.16j", Sep.15,2006

Abstract This contribution proposes the detailed frame structures for the minimum configuration of frame structure and extends this to support multi-hop relay.

Purpose Propose the text regarding frame structure design for multi-hop relay

Notice This document has been prepared to assist IEEE 802.16. It is offered as a basis for discussion and is not binding on the contributing individual(s) or organization(s). The material in this document is subject to change in form and content after further study. The contributor(s) reserve(s) the right to add, amend or withdraw material contained herein.

Release The contributor grants a free, irrevocable license to the IEEE to incorporate material contained in this contribution, and any modifications thereof, in the creation of an IEEE Standards publication; to copyright in the IEEE's name any IEEE Standards publication even though it may include portions of this contribution; and at the IEEE's sole discretion to permit others to reproduce in whole or in part the resulting IEEE Standards publication. The contributor also acknowledges and accepts that this contribution may be made public by IEEE 802.16.

Patent Policy and Procedures The contributor is familiar with the IEEE 802.16 Patent Policy and Procedures <<http://ieee802.org/16/ipr/patents/policy.html>>, including the statement "IEEE standards may include the known use of patent(s), including patent applications, provided the IEEE receives assurance from the patent holder or applicant with respect to patents essential for compliance with both mandatory and optional portions of the standard." Early disclosure to the Working Group of patent information that might be relevant to the standard is essential to reduce the possibility for delays in the development process and increase the likelihood that the draft publication will be approved for publication. Please notify the Chair <<mailto:chair@wirelessman.org>> as early as possible, in written or electronic form, if patented technology (or technology under patent application) might be incorporated into a draft standard being developed within the IEEE 802.16 Working Group. The Chair will disclose this notification via the IEEE 802.16 web site <<http://ieee802.org/16/ipr/patents/notices>>.

Comments on Frame Structure for multi-hop relay

Changyoon Oh, Youngbin Chang, Mihyun Lee, HyoungKyu Lim, Jaeweon Cho, Panyuh Joo

Samsung Electronics

Rakesh Taori

Samsung Advanced Institute of Technology

1. Introduction

In the November meeting at Dallas, there has been an agreement on the minimum configuration of frame structure. In this contribution, firstly a detailed version of the aforementioned minimum configuration frame structure is provided, which is similar to that of Figure 218 of the current specification. The frame structure agreed in [1] needs to be extended in order to allow multi-hop capability. Since there are several ways to configure a frame that enable multi-hop support, a framework approach that can accommodate sufficiently flexibility may be preferable. Accordingly, a second aspect of this contribution is to provide a generalized frame structure, similar to that of Figure 219 of the current specification, in order to support multi-hop relay..

2. Generalized Frame Structure

Figure 1 shows the minimum configuration of frame structure as agreed in the last meeting, i.e., a frame structure for two-hop relay. In this contribution Figure 2 is proposed with an aim to align Figure 1 such that it provides a similar level of detail as Figure 218 in the current specification .. In addition, it is argued that the term ‘zone’ used in the minimum configuration of frame structure may cause confusion when used together with the already existing terminology ‘zone’ as used in Figure 219, for instance. So, it is proposed that the term ‘zone’ as implied in [1] be replaced by the term ‘interval’ to avoid confusion.

More importantly, to support multi-hop relay, the agreed minimum configuration of frame structure needs to be extended. Just as Figure 219 in the current specification [2] generalizes Figure 218, Figure 3 is provided as a generalization of Figure 2, to accommodate various frame configurations for supporting the multi-hop topology. According to the generalization illustrated in Figure 3, additional intervals to allow multi-hop capability may appear in a frame based on the minimum configuration of frame structure.

To be more specific, MR-BS frame and RS frame may have additional DL/UL access interval after the DL/UL relay interval to support its MSs. Alternatively, an RS frame may have additional DL/UL relay interval either before the DL/UL relay interval or after the DL/UL relay interval to support its subordinate RS. However, the number of additional interval may need to be limited for technical feasibility.

Note that the additional access intervals shall not include FCH and DL-MAP, while the additional relay interval may include R-FCH and R-DL-MAP.

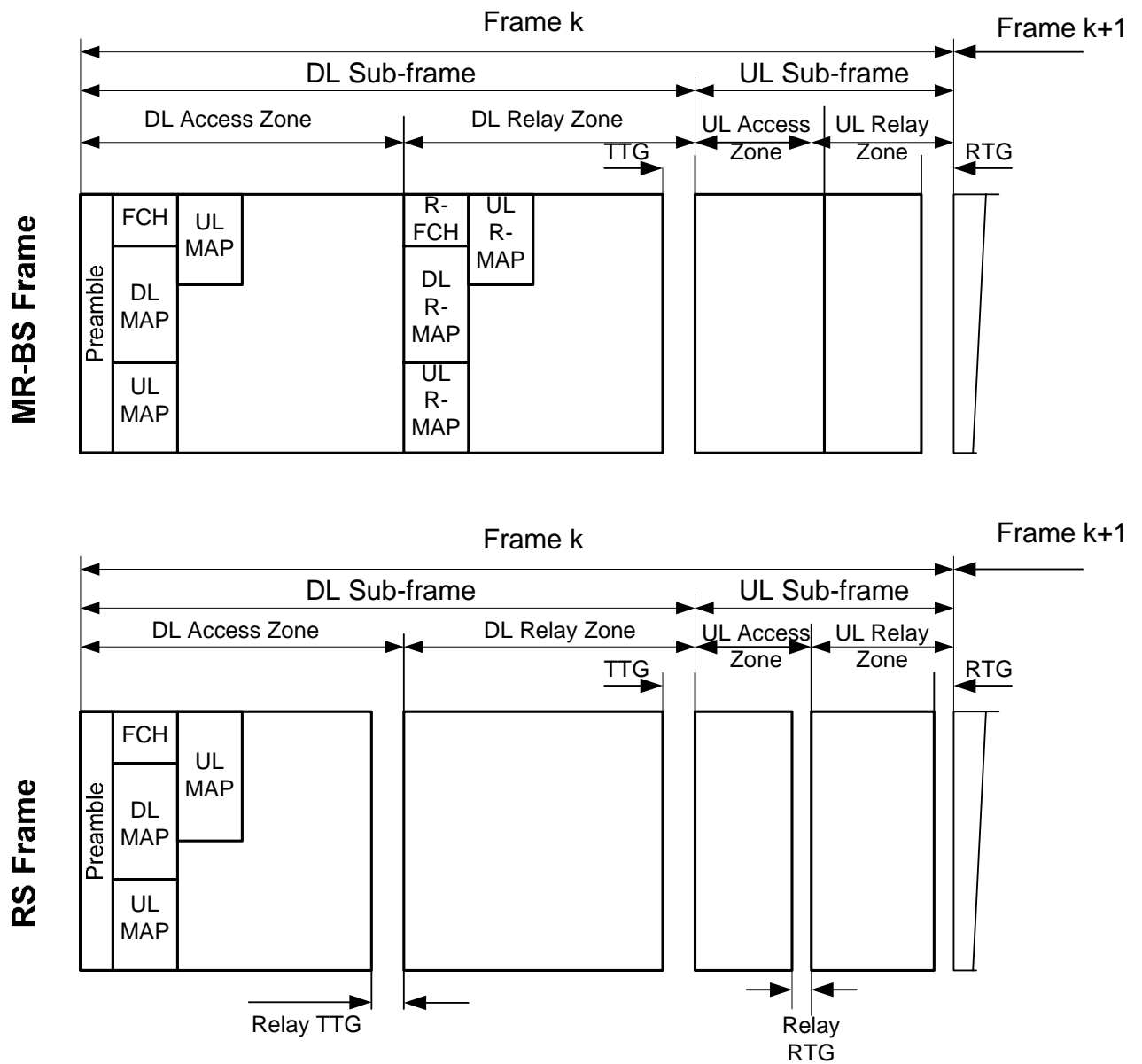

Figure 1. Example of minimum configuration for an in-band non-transparent relay frame structure (adopted from [1])

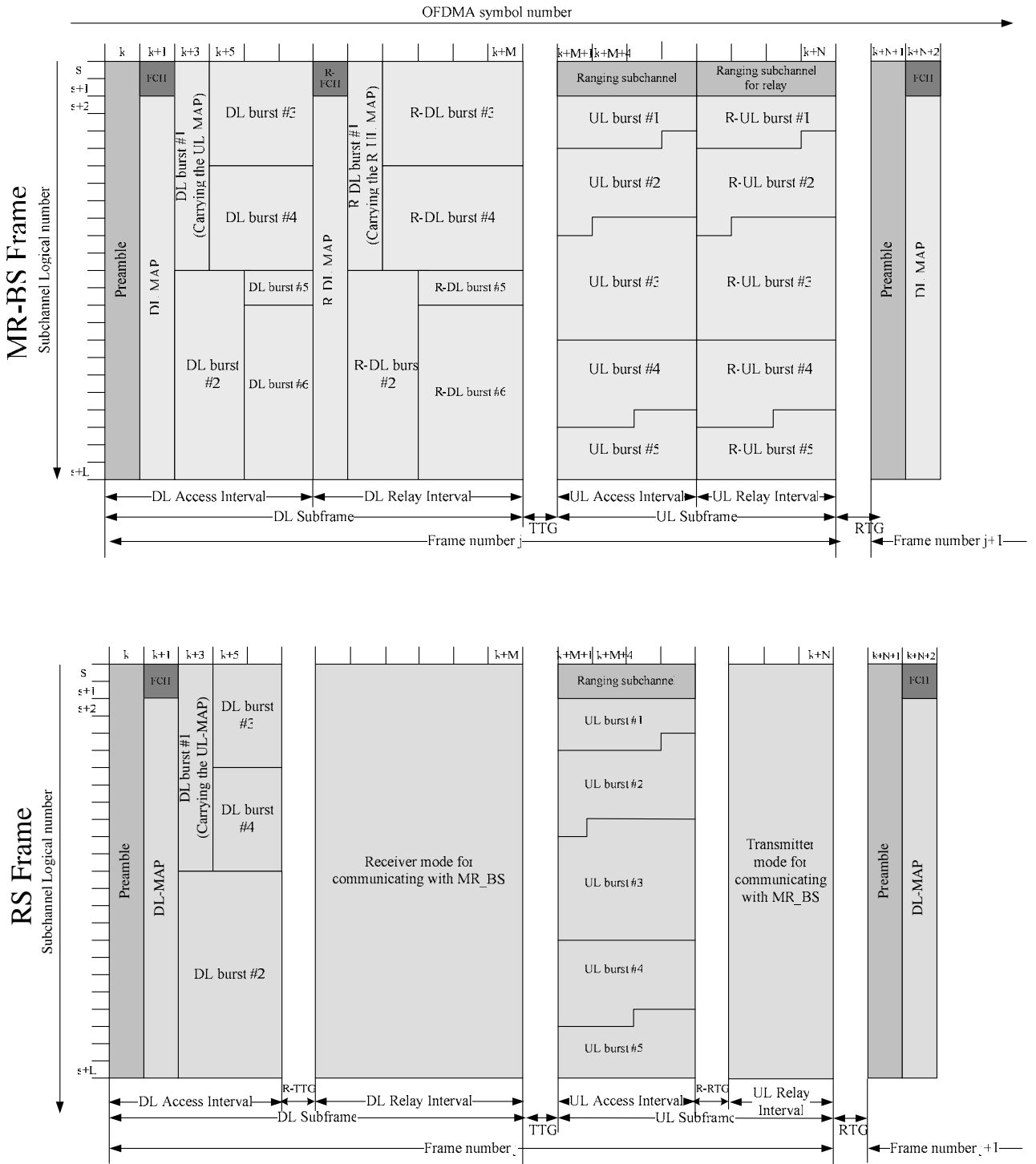

Figure 2. Example of minimum configuration for an in-band non-transparent relay frame structure (Suggested as a replacement to Figure xyz in [1]).

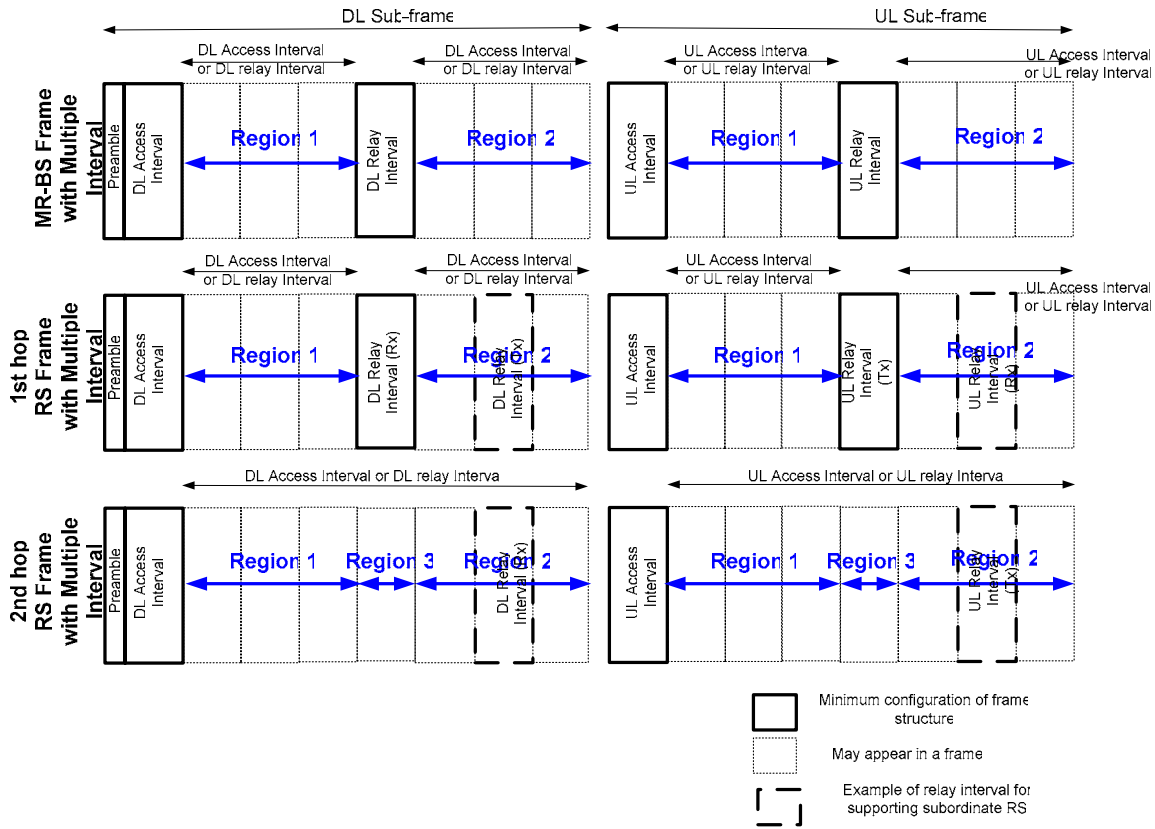

Figure 3. Relay frame with multiple intervals

3. Operation of Multi-hop Frame structure

The frame structure illustrated above can be configured for different scenarios. Consider, for example a 3-hop scenario wherein to support multi-hop relay, MR-BS frame uses the minimum configuration, while the 1st hop RS frame and 2nd RS frame enable the relay interval in region 1 to communicate with each other and the 2nd RS frame enables the access interval in region 3. In such a case, the resulting frame structure will be Figure 4.

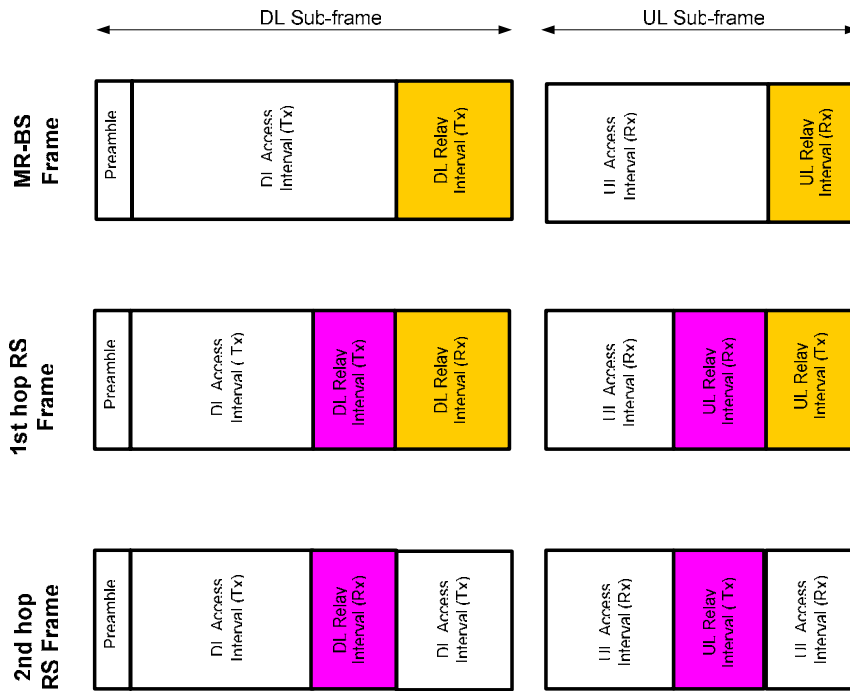

Figure 4. Example of frame structure that enables relay interval in region 1 and access interval in region 3

Consider another scenario wherein to support multi-hop relay, the MR-BS frame and the 2nd RS frame enable access interval in region 2 and in region 1, respectively and the 1st RS frame and the 2nd RS frame enable relay interval in region 2 to communicate with each other. For such a case, the resulting frame structure will be Figure 5.

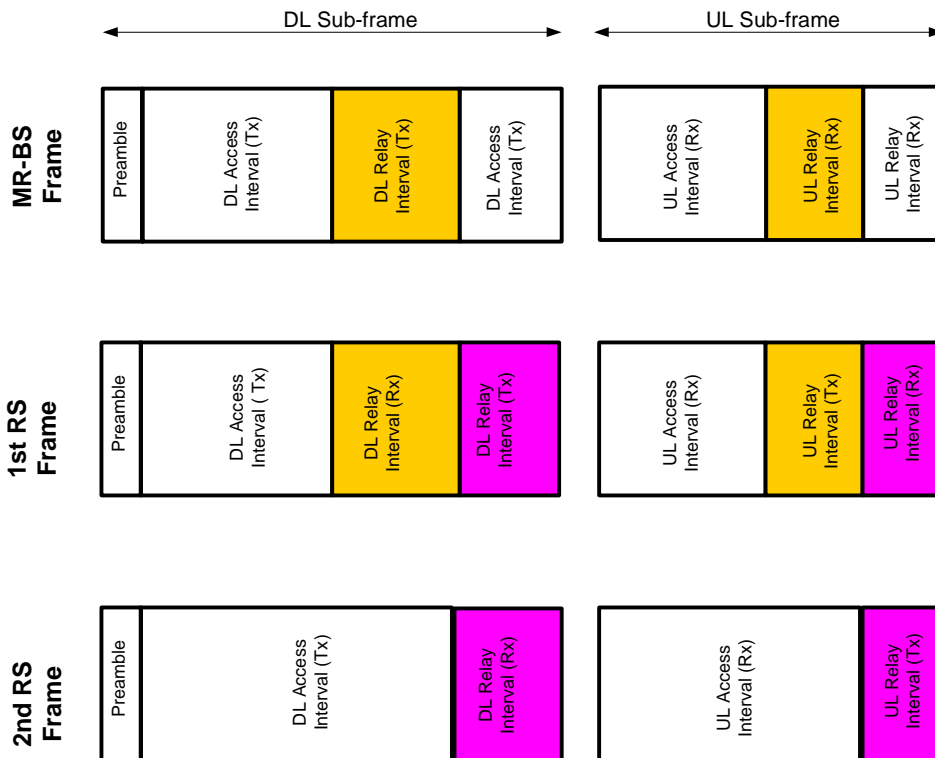

Figure 5. Example of frame structure that enables access interval in region 2 and 3 and relay interval in region 2

Consider, yet another scenario wherein to support multi-hop relay, MR-BS frame, 1st RS frame, and 2nd RS frame may enable the access interval in region 2 and the 1st RS frame and 2nd RS frame may enable the relay interval in region 2 to communicate with each other. Furthermore, 2nd RS may enable the access interval in region 3 to communicate with its MS. Then, the resulting frame structure is Figure 6.

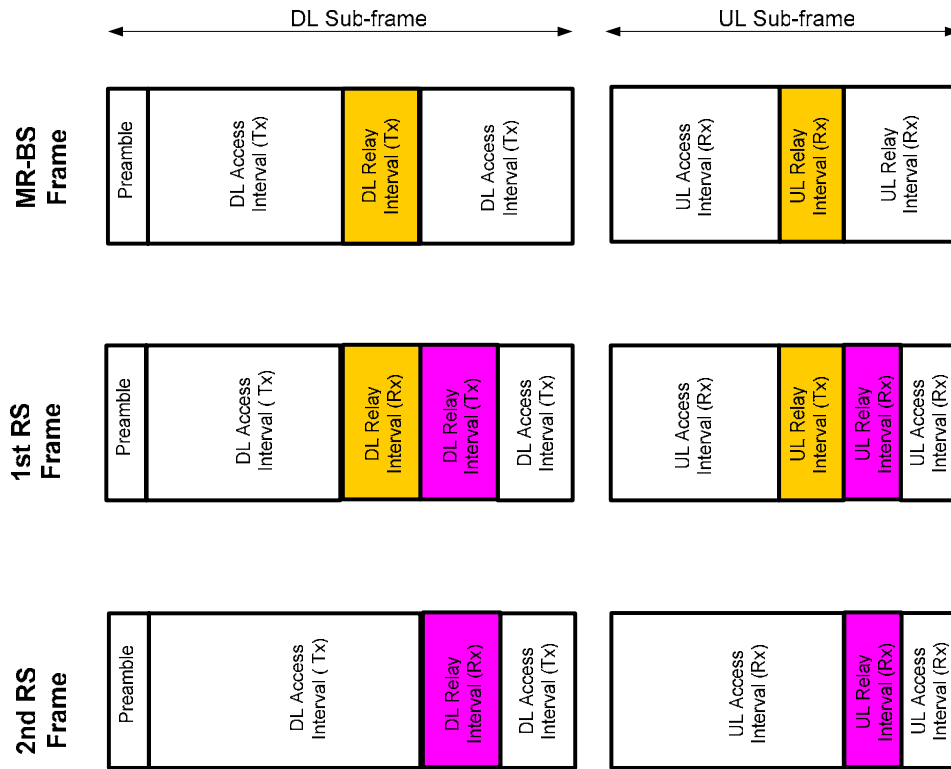

Figure 6. Example of frame structure that enables access interval in region 2 and 3 and relay interval in region 2

The illustration in Figure 3 even lends itself to frame structures that may be composed of a basic unit comprising more than one frame. An example of an MR-BS frame and an RS frame with a two frame unit, derived from the general frame structure in Figure 3, is shown in Figure 7.

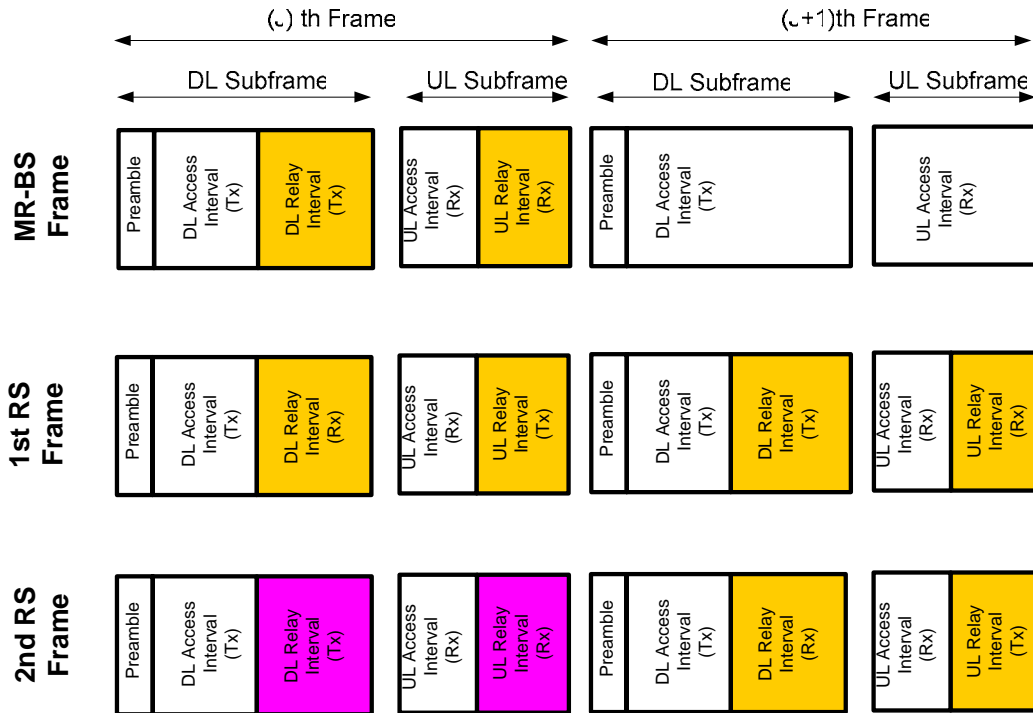

Figure 7. Example of frame structure that enable minimum configuration of frame structure in 2-frame unit

The illustration of a frame structure framework provided in Figure 3 seems to support various dedicated frame structures which can be configured in a given system by means of appropriate scheduling and the corresponding signaling mechanisms.

4. Proposed Text Change

[Remedy 1: replace ‘zone’ with ‘interval’ as follows:]

[Replace the followings at section 8.4.4.7.2:]

8.4.4.7.2.1 MR-BS frame structure

For the TDD mode, an example of the MR-BS frame structure is shown in Figure xxx.

Each MR-BS frame begins with a preamble followed by an FCH and the DL MAP and possibly UL MAP. The DL sub-frame shall include at least one DL Access ~~Zone~~ Interval and may include at least one or more DL Relay ~~Zone~~ Interval. The UL sub-frame may include at least one or more UL Access ~~Zone~~ Interval and it may include at least one or more UL Relay ~~Zone~~ Interval. In each frame, the TTG shall be inserted between the DL sub-frame and the UL sub-frame. The RTG shall be inserted at the end of each frame. In the DL Access ~~Zone~~ Interval, the subchannel allocation, the FCH transmission, and the FCH shall be defined as in Section 8.4.4.2.

The DL Relay ~~Zone~~ Interval shall include a R-FCH and a R-MAP. In the DL Relay ~~Zone~~ Interval, the subchannel allocation may be the same as that in the DL Access ~~Zone~~ Interval. The R-FCH may be the same as the FCH in

the DL Access ~~Zone~~ Interval. Other attributes of the MR-BS frame and the RS frame such as transition between modulation and coding, presence of multiple Intervals, may be the same as those described in 8.4.4.2.

The number, size, and location of the relay zones shall be configurable.

8.4.4.7.2.2 Relay frame structure

For the TDD mode, an example of an RS frame structure is shown in Figure xxx.

The Relay Station transmits its frame start preamble time aligned with its serving MR-BS frame start preamble.

The DL sub-frame shall include at least one DL Access ~~Zone~~ Interval and may include at least one or more DL Relay ~~Zone~~ Interval. The additional DL access interval may be placed after the relay interval. The additional DL relay interval may be placed either before the relay interval or after the relay interval to communicate with its subordinated Relay station. An R-TTG may be placed between a DL Access ~~Zone~~ Interval and a DL Relay ~~Zone~~ Interval. The UL sub-frame may include at least one or more UL Access ~~Zone~~ Interval and at least one or more UL Relay ~~Zone~~ Interval. An R-RTG may be placed between a UL Access ~~Zone~~ Interval and a UL Relay ~~Zone~~ Interval.

If the relay station switches from transmission to reception mode, an R-TTG shall be required. If the relay station switches from reception to transmission mode, an R-RTG shall be required. There may be more than one R-TTG and more than one R-RTG inserted in the RS frame. In each frame, the TTG shall be inserted between the DL sub-frame and the UL sub-frame. The RTG shall be inserted at the end of each frame.

The contents of the FCH, DL MAP, and UL MAP in the Relay Frame may be different from those in the MR-BS Frame.

Each RS frame begins with a preamble followed by an FCH and the DL MAP and possibly a UL MAP. In the DL Access ~~Zone~~ interval, the subchannel allocation, the FCH transmission, and the FCH shall be as defined in Section 8.4.4.2. The content of the number, size, and location of the relay intervals shall be configurable.

Figure yyy depicts the BS frame and the RS frame with multiple intervals.

[Remedy 2: Replace Figure]

[Replace Figure xxx with Figure yyy as follows:]

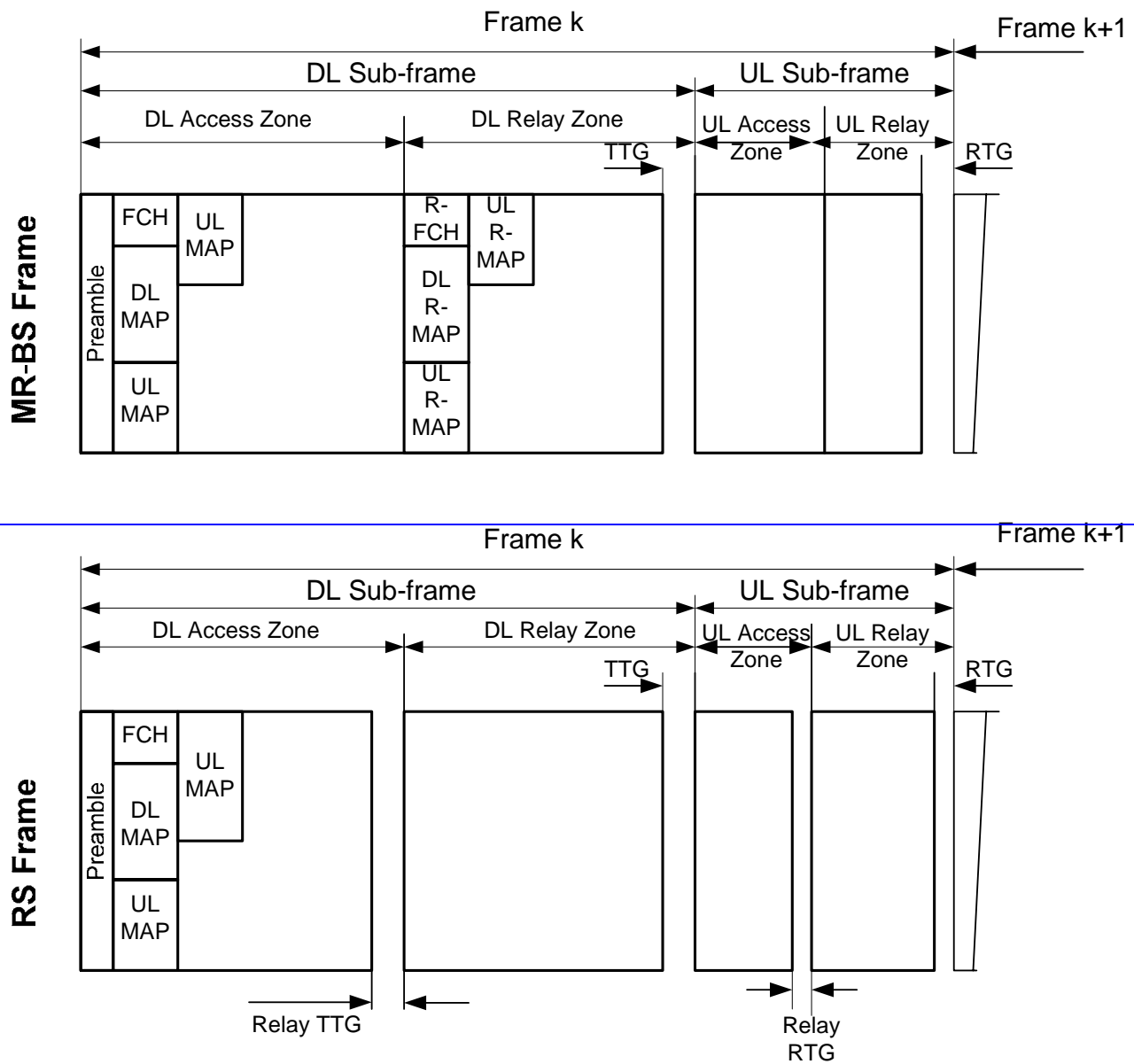

Figure xxx Example of minimum configuration for an in-band non-transparent relay frame structure

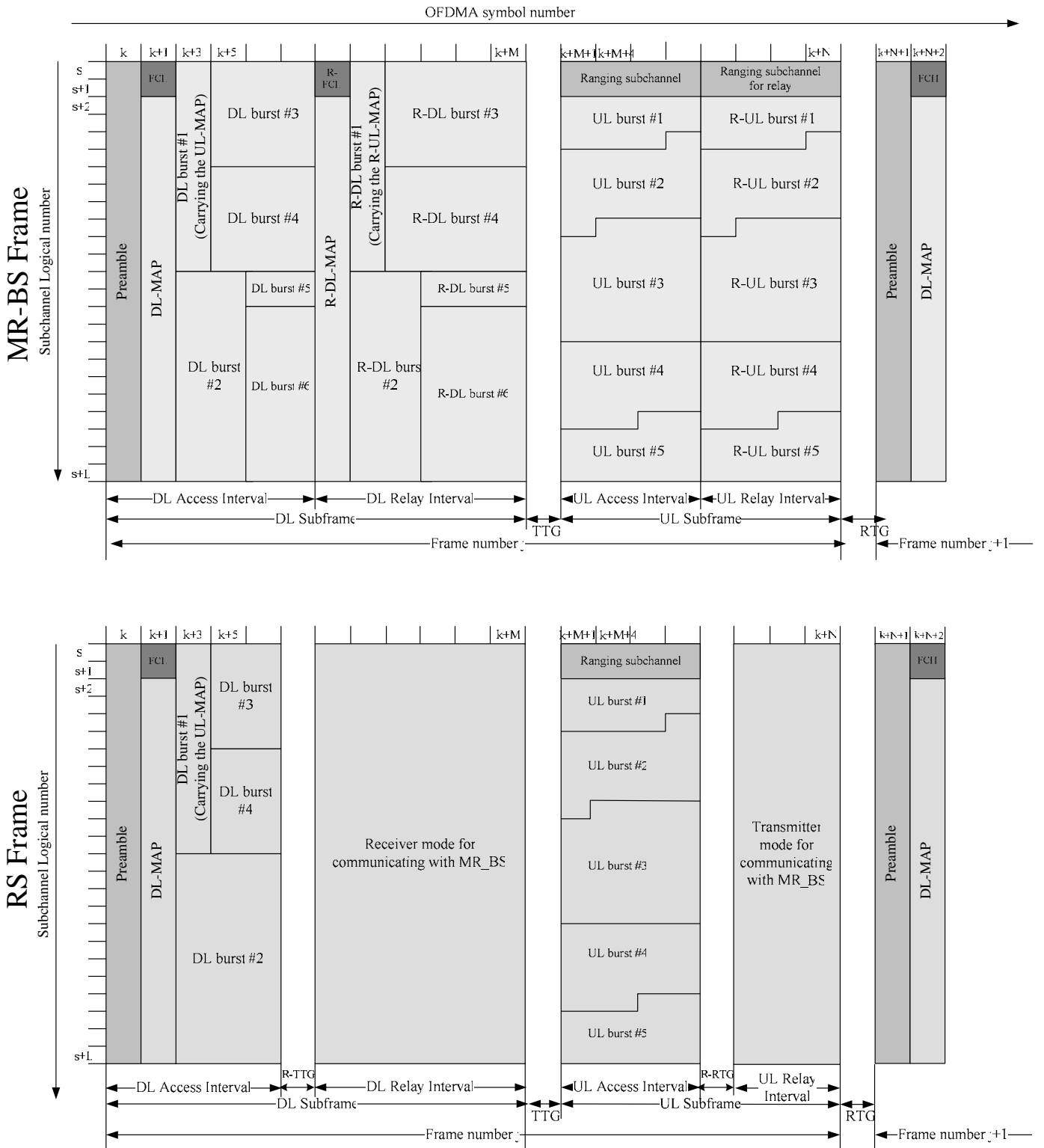

Figure yyy Example of minimum configuration for an in-band non-transparent relay frame structure

[Remedy 3: Insert Figure]

[Insert Figure zzz at the end of section 8.4.4.7.2 .2]

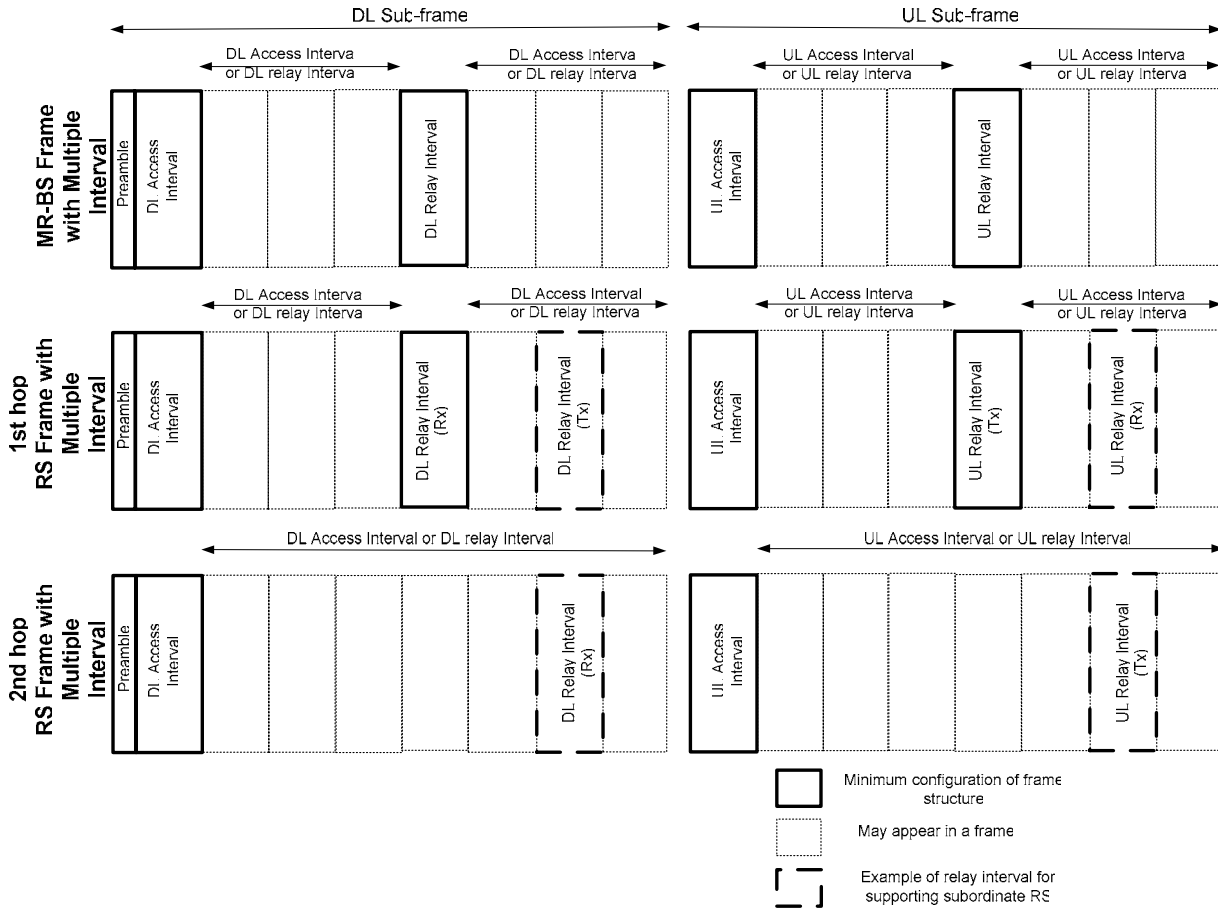

Figure zzz Relay frame with multiple intervals

References

- [1] IEEE 802.16j-06/233r9, “Relaying Frame Structure”, Nov. 2006
- [2] IEEE 802.16-2005, “IEEE Standard for Local and metropolitan area networks-Part 16: Air Interface for Fixed and Mobile Broadband Wireless Access Systems: Amendment 2: Physical and Medium Access Control Layers for Combined Fixed and Mobile Operation in Licensed Bands and Corrigendum 1.