

Project	IEEE 802.16 Broadband Wireless Access Working Group < http://ieee802.org/16 >	
Title	Early Handover Trigger	
Date Submitted	2007-01-08	
Source(s)	Yong-Hoon Choi, Young-uk Chung, Hyukjoon Lee Kwangwoon University 447-1 Wolgye-Dong, Nowon-Gu Seoul, 139-701, Korea Hyun Jae Kim Young-il Kim ETRI 161 Gajeong-Dong, Yuseong-Gu, Deajeon, 305-350, Korea	Voice: +82-2-940-5590 Fax: +82-2-940-5590 yhchoi@kw.ac.kr yuchung@kw.ac.kr hlee@kw.ac.kr khjgo@etri.re.kr yikim@etri.re.kr
Re:	This is a response to a Call for Technical Proposals regarding IEEE Project P802.16j	
Abstract	This document proposes early handover trigger event and corresponding MAC management event that is useful for reducing handover latency by cross-layer optimization in IEEE802.16j network.	
Purpose	This document is provided as input for the IEEE802.16j amendment.	
Notice	This document has been prepared to assist IEEE 802.16. It is offered as a basis for discussion and is not binding on the contributing individual(s) or organization(s). The material in this document is subject to change in form and content after further study. The contributor(s) reserve(s) the right to add, amend or withdraw material contained herein.	
Release	The contributor grants a free, irrevocable license to the IEEE to incorporate material contained in this contribution, and any modifications thereof, in the creation of an IEEE Standards publication; to copyright in the IEEE's name any IEEE Standards publication even though it may include portions of this contribution; and at the IEEE's sole discretion to permit others to reproduce in whole or in part the resulting IEEE Standards publication. The contributor also acknowledges and accepts that this contribution may be made public by IEEE 802.16.	
Patent Policy and Procedures	The contributor is familiar with the IEEE 802.16 Patent Policy and Procedures < http://ieee802.org/16/ipr/patents/policy.html >, including the statement "IEEE standards may include the known use of patent(s), including patent applications, provided the IEEE receives assurance from the patent holder or applicant with respect to patents essential for compliance with both mandatory and optional portions of the standard." Early disclosure to the Working Group of patent information that might be relevant to the standard is essential to reduce the possibility for delays in the development process and increase the likelihood that the draft publication will be approved for publication. Please notify the Chair < mailto:chair@wirelessman.org > as early as possible, in written or electronic form, if patented technology (or technology under patent application) might be incorporated into a draft standard being developed within the IEEE 802.16 Working Group. The Chair will disclose this notification via the IEEE 802.16 web site < http://ieee802.org/16/ipr/patents/notices >.	

Early Handover Trigger

**Yong-Hoon Choi, *Young-uk Chung, *Hyukjoon Lee, ** Hyun Jae Kim, and **Young-il Kim*

**Kwangwoon University, **ETRI*

1. Introduction

With introducing relay stations (RS) into IEEE802.16 network, seven handover cases are considered [1]. If we take RS-mobility (e.g., nomadic or mobile RS) into account, the handover problem becomes very complicated. Besides, handover occurs frequently in the mobile multi-hop relay (MMR) network. Since handover latency could degrade (or disrupt) quality of service, techniques for reducing the handover delay could be one of the most important issues in MMR network.

In this contribution, we propose early handover trigger event and corresponding MAC management messages over relay links. The early handover trigger can accelerate handover process so that a mobile station (MS) can continue to enjoy seamless services.

2. Early Handover Trigger

MAC layer (L2) handover procedures and corresponding MAC management messages have been defined in IEEE802.16e. The strict separation between IEEE802.16e MAC and L3 handover scheme (e.g., Mobile IPv4) will have negative consequences for total handover latency. Furthermore in multi-hop relay environment, the handover frequency increases, and therefore a method to reduce the total handover latency is necessary.

An early handover trigger, so called L2 trigger, is a signal of an L2 event and it is early notice of an upcoming change in the L2 point of attachment of the MS to the access network. The L2 event may come explicitly from IEEE802.16e/j MAC in a solicited or unsolicited manner, or it may be derived from IEEE802.16 MAC messages. Usually the L3 handover latency is far greater than MAC-layer handover latency, MAC messages initiating handover such as MOB_MSHO-REQ or MOB_BSHO-REQ are not proper to use as an early handover trigger event. MAC layer event advance to handover initiation message is suitable for an early handover trigger. Upon receiving the trigger event, corresponding local or remote L3 layer will start the L3 handover procedure.

3. Early Handover Trigger Condition

The early handover trigger condition as well as the handover decision algorithm is beyond the scope of the IEEE802.16e/j standard. In this proposal, we describe early handover trigger condition as an example (not for an input to the standard).

In order to generate trigger event to upper layer (sometimes to remote RS or MR-BS) prior to starting MAC layer handover process, some prediction or estimation scheme needs to be applied. One example is to use signal quality samples as an input to interval estimator. See the following simple method:

RS or MR-BS monitors the signal quality for a specific connection at regular intervals T . Suppose that X_1, X_2, \dots, X_n is a sample from a large population having unknown real mean signal quality μ and variance σ^2 . Let us consider an interval estimate of μ . When n is sufficiently large, we can establish a confidence interval for μ by considering the sampling distribution of \bar{X} . According to the central limit theorem, we can expect that the

sampling distribution of \bar{X} to be approximately normally distributed with mean $\mu_{\bar{X}} = \mu$ and standard deviation $\sigma_{\bar{X}} = \sigma/\sqrt{n}$. When σ is unknown and $n \geq 30$, S can replace σ . Here, S is the sample standard deviation. A $(1 - \alpha) \times 100$ percent confidence interval for μ is given by

$$\left(\bar{X} - z_{\alpha/2} \frac{S}{\sqrt{n}}, \bar{X} + z_{\alpha/2} \frac{S}{\sqrt{n}} \right)$$

where $z_{\alpha/2}$ is the z-value leaving an area of $\alpha/2$ to the right in standard normal distribution probability density function (PDF). To find 95% confidence interval, we get $z_{0.025} = 1.96$; to find 99% confidence interval, we get $z_{0.005} = 2.58$. The term $\bar{X} - z_{\alpha/2} \frac{S}{\sqrt{n}}$ is called the lower confidence limit, and can be interpreted as threshold of handover early trigger event.

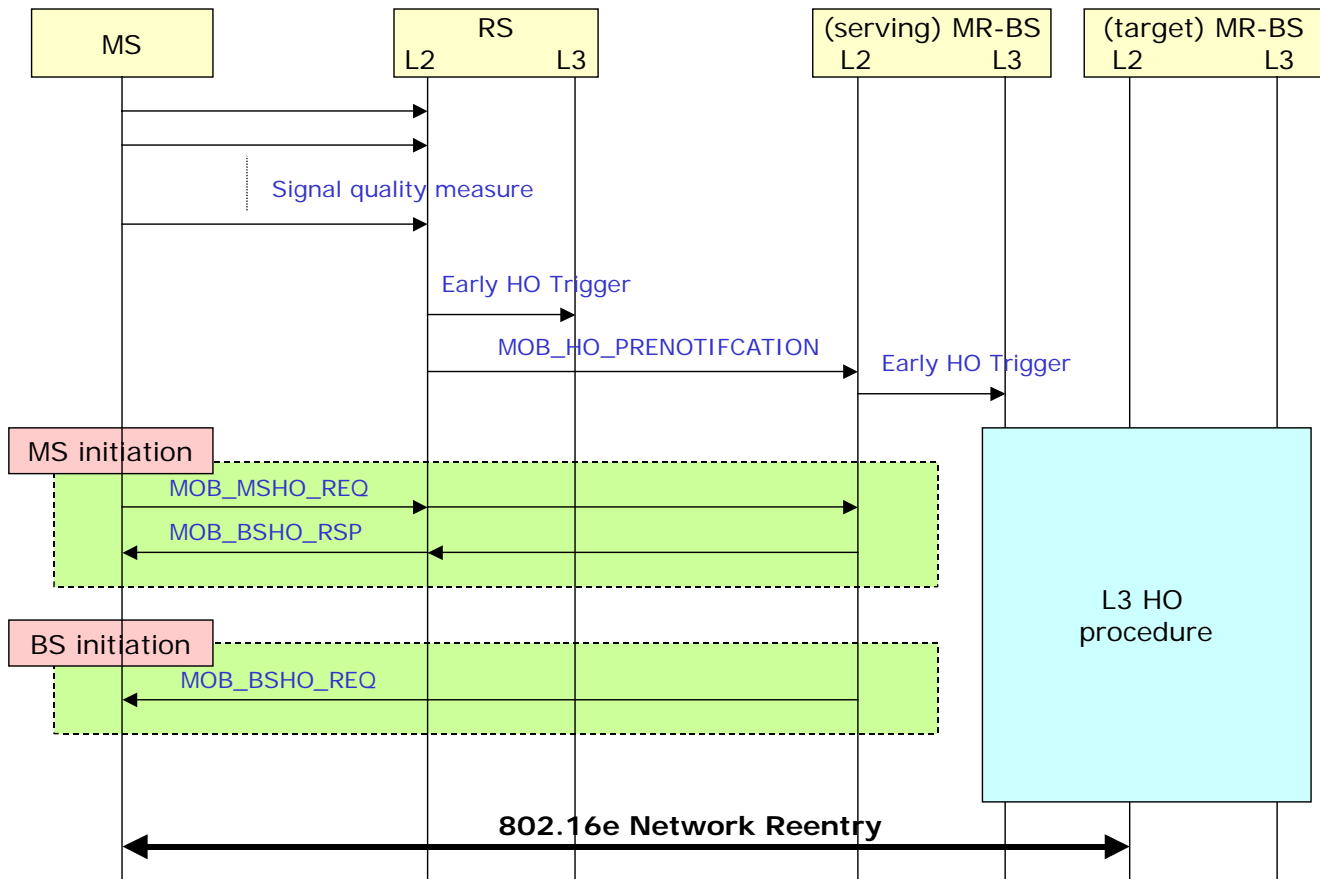

Fig. 1: Handover early trigger and message exchange flow

Handover early trigger event is generated when the value of the lower confidence limit is smaller than a certain handover threshold Q_T . Although the value of measured sample is greater than the threshold Q_T , the value of interval estimator can be smaller than Q_T . Thus, handover early trigger event can be generated prior to starting MAC layer handover process.

Upon receiving the L2 Trigger event, corresponding L3 handover procedure may start. In a centralized MR network using simple RSs, an MR-BS handles all handover-related information. To support this case, RS should let the MR-BS know the L2 trigger event occurred in the RS. For this purpose, we propose a new MAC management message MOB_HO_PRENOTIFICATION, which includes basic CID, RSID, and signal quality information. The message format can be found in Section 4. Fig. 1 shows the procedure described above.

4. Proposed Text Changes

[Insert new subclause 6.3.22.1.2.1]

6.3.22.1.2.1 Handover Early Trigger

An early handover trigger, so called L2 trigger, is a signal of an L2 event and it is early notice of an upcoming change in the L2 point of attachment of the MS to the access network. An RS may generate early handover trigger event to accelerate corresponding L3 handover procedure so that total handover latency can be reduced. To support centralized MR network, early trigger event is transmitted to MR-BS by MOB_HO-PRENOTIFICATION message. Upon reception of the MOB_HO-PRENOTIFICATION message, the MR-BS shall start L3 handover procedure.

[Insert new subclause 6.3.2.3.xx]

6.3.2.3.xx MOB_HO-PRENOTIFICATION message

The RS or MR-BS may transmit a MOB_HO-PRENOTIFICATION message when a handover is expected in the near future. This message may be generated prior to MOB_MSHO-REQ or MOB_BSHO-REQ message. The message shall be transmitted on the basic CID.

Syntax	Size (bits)	Notes
MOB_HO-PRENOTIFICATION_Message_format() {		
Management Message Type = TBD	8	To be defined
RSID	48	Current relay station ID
Report metric	8	Bitmap indicating presence of metric in message Bit 0: RS CINR mean Bit 1: RS RSSI mean Bit 2: RS RTD Bit 3-7: <i>reserved</i> ; shall be set to zero
Basic CID	16	
If(Report metric[Bit#0] == 1)		
RS CINR mean	8	

If(Report metric[Bit#1] == 1)		
RS RSSI mean	8	
If(RS RTD[Bit#2] == 1)		
RS RTD	8	This field will include the round trip delay of a particular MS.
Service level prediction	8	
<i>Padding</i>	<i>variable</i>	Padding bits to ensure byte aligned.
TLV encoded information	<i>variable</i>	
}		

An RS shall generate MOB_HO-PRENOTIFICATION message in the format shown in the table. The following parameters shall be included in the MOB_HO-PRENOTIFICATION message.

Report metric

Bitmap indicator of trigger metrics that the RS reports in this message. For each bit location a value of '0' indicates the trigger metric should not be included, while a value '1' indicates the trigger metric should be included in the message. The bitmap interpretation for the metrics shall be:

Bit 0: CINR mean between a particular MS and RS

Bit 1: RSSI mean between a particular MS and RS

Bit 2: RS RTD

Bit 3-7: reserved; shall be set to zero

According to the Report metric, the MOB_HO-PRENOTIFICATION message includes the following parameters.

RS CINR mean

The RS CINR mean parameter indicates the CINR in dB measured at the RS on the downlink signal of a particular MS. The value shall be interpreted as a signed byte with the resolution of 0.5 dB. The measurement shall be performed on the subcarriers on the frame preamble and averaged over the measurement period.

RS RSSI mean

The RS RSSI mean parameter indicates the received signal strength measured by the RS to the particular MS. The value shall be interpreted as an unsigned byte with units of 0.25 dB, such that 0x00 is interpreted as -103.75 dBm, an RS shall be able to report values in the range -103.75 dBm to 40 dBm. The measurement shall be performed on the frame preamble and averaged over the measurement period.

RS RTD

The RS RTD parameter indicates the round trip delay (RTD) measured by RS to the particular MS. RTD can be given by the latest time advance taken by RS. The value shall be interpreted as an unsigned byte with unit of 1F/s (see 10.3.4.3).

Service level prediction

The service level prediction value indicates the level of service the MS can expect from this RS. The following encodings apply:

0 = No service is possible for this MS

1 = Some service is available for one or several service flows authorized for the MS.

2 = For each authorized service flow, a MAC connection can be established with QoS specified by the AuthorizedQoSParmaSet.

3 = No service level prediction is available.

5. References

- [1] Hyunjeong Lee et al., "Overview of the proposal for MS MAC handover procedure in an MR network," IEEE C802.16j-06/217, Nov. 2006.