

Project	IEEE 802.16 Broadband Wireless Access Working Group < http://ieee802.org/16 >	
Title	Remedy for relaying compressed DL-MAP/UL-MAP, HARQ-MAP and SUB-DL-UL-MAP	
Date Submitted	2007-07-19	
Source(s)	Kanchei (Ken) Loa, Yi-Hsueh Tsai, Hua-Chiang Yin, Shiann Tsong Sheu, Yung-Ting Lee, Youn-Tai Lee Institute for Information Industry 8F, No. 218, Sec. 2, Dunhua S. Rd., Taipei City 106, Taiwan Hongyun Qu, Mary Chion ZTE Corporation	Voice: +886-2-27399616 Fax: +886-2-23782328 loa@iii.org.tw qu.hongyun@zte.com.cn mchion@zteusa.com
Re:	IEEE 802.16j-07/019: "Call for Technical Comments Regarding IEEE Project 802.16j"	
Abstract	This contribution proposes the enhanced remedy of relaying compressed DL-MAP and UL-MAP, HARQ-MAP and SUB-DL-UL-MAP, which do not have MAC headers and management message types.	
Purpose	Text proposal for 802.16j Baseline Document.	
Notice	<i>This document does not represent the agreed views of the IEEE 802.16 Working Group or any of its subgroups. It represents only the views of the participants listed in the "Source(s)" field above. It is offered as a basis for discussion. It is not binding on the contributor(s), who reserve(s) the right to add, amend or withdraw material contained herein.</i>	
Release	The contributor grants a free, irrevocable license to the IEEE to incorporate material contained in this contribution, and any modifications thereof, in the creation of an IEEE Standards publication; to copyright in the IEEE's name any IEEE Standards publication even though it may include portions of this contribution; and at the IEEE's sole discretion to permit others to reproduce in whole or in part the resulting IEEE Standards publication. The contributor also acknowledges and accepts that this contribution may be made public by IEEE 802.16.	
Patent Policy	The contributor is familiar with the IEEE-SA Patent Policy and Procedures: < http://standards.ieee.org/guides/bylaws/sect6-7.html#6 > and < http://standards.ieee.org/guides/opman/sect6.html#6.3 >. Further information is located at < http://standards.ieee.org/board/pat/pat-material.html > and < http://standards.ieee.org/board/pat >.	

Remedy for relaying compressed DL-MAP/UL-MAP, HARQ-MAP and SUB-DL-UL-MAP

*Kanchei (Ken) Loa, Yi-Hsueh Tsai, Hua-Chiang Yin,
Shiann Tsong Sheu, Yung-Ting Lee, Youn-Tai Lee
Hongyun Qu, Mary Chion
Institute for Information Industry (III), ZTE*

1. Introduction

In MR networks under centralized scheduling, the RS shall relay the FCH, compressed DL-MAP/UL-MAP, HARQ-MAP and SUB-DL-UL-MAP for the subordinated RSs to broadcast on the access links. However, the associated relaying schemes have not been defined in the baseline document IEEE 802.16j-06/026r4 yet.

This contribution proposes the remedy of relaying FCH, compressed DL-MAP/UL-MAP, HARQ-MAP and SUB-DL-UL-MAP in the centralized control and centralized scheduling scenario. Because there is no MAC header and management message type defined in these MAPs, we propose a new message to encapsulate these MAPs for relaying.

And because MR-BS has to do the scheduling for RSs with centralized scheduling for each frame, if every frame MR-BS sends MAP messages which include all the scheduling information and configuration information, it will cause very large overhead. So we also propose two RS scheduling messages for RS access zone and RS relay zone respectively which include only changed configuration information and scheduling information.

In order to facilitate the incorporation of this proposal into IEEE 802.16j standard, specific changes to the baseline working document IEEE 802.16j-06/026r4 are listed below. Moreover, the compressed DL-MAP/UL-MAP, HARQ-MAP, SUB-DL-UL-MAP, and HARQ and SUB-MAP Pointer IE defined in IEEE 802.16e-2005 are provided in Table 1~5 below for reference.

Table 1: Format of Compressed DL-MAP

Syntax	Size	Notes
Compressed DL-MAP () {	-	-
Compressed map indicator	3	Set to binary 110 to indicate a compressed map format
UL-MAP appended	1	
Reserved	1	Shall be set to zero
Map message length	11	This value specifies the length of the compressed map message(s) beginning with the byte containing the Compressed map indicator and ending with the last byte of the compressed DL-MAP message if the UL-MAP appended bit is not set or the last byte of the UL-MAP compressed message if the UL-MAP appended bit is set. The length includes the computed 32-bit CRC value
PHY Synchronization Field() {	-	-
Frame Duration Code	8 bits	
Frame Number	24 bits	
}	-	-
DCD Count	8 bits	

Operator ID	8 bits	
Sector ID	8 bits	
No. OFDMA symbols	8 bits	Number of OFDMA symbols in the DL subframe including all AAS/permutation zone.
DL IE count	8 bits	
for ($n = 0; n < \text{DL IE count}; n++$) {	-	For each DL-MAP element 1 to N .
DL-MAP_IE()	<i>variable</i>	-
}	-	-
if !(byte boundary) {		
Padding Nibble	4 bits	Padding to reach byte boundary.
}		
}	-	-

Table 2 Format of Compressed UL-MAP

Syntax	Size	Notes
Compressed UL-MAP() {		
UCD Count	8 bits	
Allocation Start Time	32 bits	
No. OFDMA symbols	8 bits	Number of OFDMA symbols in the UL subframe
while (map data remains){	-	
UL-MAP_IE()	<i>variable</i>	
}		
if !(byte boundary) {		
Padding Nibble	4 bits	Padding to reach byte boundary.
}		
}		

Table 3: Format of HARQ-MAP

Syntax	Size	Notes
HARQ_MAP message format() {	-	-
HARQ MAP Indicator = 111	3 bits	Set to 0b111
Compact UL_MAP appended	1 bit	
<i>reserved</i>	1 bit	Shall be zero
Map message length	9 bits	Length of HARQ MAP in bytes. (This value specifies the length of the HARQ MAP message beginning with the byte containing the HARQ MAP indicator and ending with the last byte of the HARQ MAP message. The length includes the computed 32-bit CRC value.)
DL IE count	6 bits	Number of DL IE in the burst.
For ($n = 0; n < \text{DL IE count}; n++$) {	-	For each DL-MAP element 1 to N .
Compact DL-MAP IE ()	<i>variable</i>	-
}	-	-
If (Compact_UL-MAP appended == 1){		
while (map data remains){	-	
Compact UL-MAP_IE()	<i>variable</i>	
}		
}		

if !(byte boundary) {		
Padding Nibble	4 bits	Padding to reach byte boundary.
}		
}	-	-

Table 4: Format of Sub-DL-UL-MAP

Syntax	Size	Notes
Sub-DL-UL-MAP () {	-	-
Compressed map indicator	3 bits	Set to 0b111
Map message length	10 bits	The length of the submap message in bytes including the compressed map indicator and the 16-bit CRC .
RCID_Type	2 bits	0b00 = Normal CID 0b01 = RCID11 0b10 = RCID7 0b11 = RCID3
HARQ ACK offset indicator	1 bit	
If (HARQ ACK offset indicator == 1){	-	
DL HARQ ACK offset	8 bits	
UL HARQ ACK offset	8 bits	
}	-	-
DL IE count	8 bits	
for ($n = 0; n < \text{DL IE count}; n++$) {	-	For each DL-MAP element 1 to N .
DL-MAP_IE()	<i>variable</i>	-
}	-	-
OFDMA Symbol offset	8 bits	This value indicates start symbol offset of subsequent subbursts in this UL Allocation Start IE
Subchannel offset	7 bits	This value indicates start subchannel offset of subsequent subbursts in this UL Allocation Start IE
<i>reserved</i>	1 bit	Shall be zero
while (map data remains){	-	
UL-MAP_IE()	<i>variable</i>	
}		
if !(byte boundary) {		
Padding Nibble	4 bits	Padding to reach byte boundary.
}		
}	-	-

Table 5: HARQ and SUB-MAP Pointer IE format

Syntax	Size (bit)	Notes
HARQ and SUB-MAP Pointer IE () {	—	—
Extended DIUC	4	HARQ_P = 0x07
Length	4	—
While (data remains) {	—	—
DIUC	4	Indicates the AMC level of the burst containing a HARQ MAP message
No. Slots	8	The number of slots allocated for the burst containing a HARQ MAP message

Repetition Coding Indication	2	0b00: No repetition coding 0b01: Repetition coding of 2 used 0b10: Repetition coding of 4 used 0b10: Repetition coding of 6 used
MAP Version	2	0b00: HARQ MAPv1 0b01: Submap 0b10: Submap with CID mask included 0b11: Reserved
If (MAP Version == 0b10) {	—	—
Idle users	1	Bursts for idle users included in the submap
Sleep users	1	Bursts for sleep users included in the submap
CID Mask Length	2	0b00: 12 bits 0b01: 20 bits 0b10: 36 bits 0b11: 52 bits
CID mask	N	n = The number of bits of CID mask is determined by CID Mask Length. When the MAP message pointed by this pointer IE includes any MAP IE for an awake mode MS, the bit index corresponding to ((Basic CID of the MS) MOD n) in this CID Mask field shall be set to 1. Otherwise, it may be set to 0.
}	—	—
}	—	—
Reserved	0 or 4	For a byte alignment of IE. Shall be set to zero
}	—	—

2.

3. Spec Changes

[Insert the following subclauses 6.3.2.3.92 and 6.3.2.3.93 in line 53 of page 65]

6.3.2.3.92 RS Access MAP (RS-Access-MAP) message

This message shall be generated by MR-BS for RS with centralized scheduling. This message contains allocation information for RS to transmit in RS access zone. This message shall be sent once per frame over RS's basic connection. After the reception of RS Access MAP message, RS shall compose FCH, and possibly the associated MAPs such as DL/UL-MAP message, Compressed DL/UL-MAP, SUB-DL-UL-MAPs message and HARQ MAP message, etc., based on its RS-Access-MAP message and other related configuration messages.

Table xxx – RS Access MAP message format

<u>Syntax</u>	<u>Size</u>	<u>Notes</u>
<u>RS Access MAP Message Format{</u>	<u>=</u>	<u>=</u>
<u> Management Message Type = 98</u>	<u>8 bits</u>	

<u>Indicator</u>	<u>8 bits</u>	<u>Bit 0: 0: Parameters of DL Frame Prefix remain same with the latest Configuration.</u> <u>1: The parameters of DL Frame Prefix are updated.</u> <u>Bit 1: 0: RS shall use Normal map format.</u> <u>1: RS shall use Compressed map format</u> <u>Bit 2: 0: DL-MAP not included</u> <u>1: DL-MAP included</u> <u>Bit 3: 0: UL-MAP not included</u> <u>1: UL-MAP included</u> <u>Bit 4: 0: SUB-DL-UL-MAP not included</u> <u>1: SUB-DL-UL-MAP included</u> <u>Bit 5: 0: HARQ-MAP not included</u> <u>1: HARQ-MAP included</u> <u>Bit 6-7: reserved</u>
<u>If(bit #0 of Indicator == 1) {</u>	<u>=</u>	<u>=</u>
<u>Used subchannel bitmap</u>	<u>6 bits</u>	<u>“Used subchannel bitmap” in DL Frame Prefix</u>
<u>Repetition Coding Indication</u>	<u>2 bits</u>	<u>“Repetition Coding Indication” in DL Frame Prefix</u>
<u>Coding Indication</u>	<u>3 bits</u>	<u>“Coding Indication” in DL Frame Prefix</u>
<u>}</u>	<u>=</u>	<u>=</u>
<u>If(bit #2 of Indicator == 1) {</u>	<u>=</u>	<u>information for RS DL-MAP or Compressed DL-MAP</u>
<u>DCD Count</u>	<u>8 bits</u>	<u>“DCD Count” in DL-MAP or Compressed DL-MAP</u>
<u>No. OFDMA Symbols</u>	<u>8 bits</u>	<u>“No. OFDMA Symbols” in DL-MAP or Compressed DL-MAP</u>
<u>DL IE count</u>	<u>8 bits</u>	<u>Number of DL-MAP IE</u>
<u>For (i = 0; i < DL IE count; i++) {</u>	<u>=</u>	<u>=</u>
<u>DL-MAP IE ()</u>	<u>variable</u>	<u>“DL-MAP IE” in DL-MAP or Compressed DL-MAP</u>
<u>}</u>	<u>=</u>	<u>=</u>
<u>}</u>	<u>=</u>	<u>=</u>
<u>If(bit #3 of Indicator == 1) {</u>	<u>=</u>	<u>information for RS UL-MAP or Compressed UL-MAP</u>
<u>UCD Count</u>	<u>8 bits</u>	<u>“UCD Count” in UL-MAP or Compressed UL-MAP</u>
<u>UL IE count</u>	<u>8 bits</u>	<u>Number of UL-MAP IE</u>
<u>For (i = 0; i < UL IE count; i++) {</u>	<u>=</u>	<u>=</u>
<u>UL-MAP IE ()</u>	<u>variable</u>	<u>“UL-MAP IE” in UL-MAP or Compressed UL-MAP</u>
<u>}</u>		
<u>}</u>	<u>=</u>	<u>=</u>
<u>If(bit #4 of Indicator == 1) {</u>	<u>=</u>	<u>SUB-DL-UL-MAP information</u>
<u>Nr of SUB-MAP</u>	<u>2 bits</u>	<u>Number of SUB-DL-UL-MAP</u>
<u>For (i = 0; i < Nr of SUB-MAP; i++) {</u>	<u>=</u>	
<u>Reduced SUB-DL-UL-MAP()</u>		
<u>}</u>		
<u>}</u>	<u>=</u>	<u>=</u>
<u>If(bit #5 of Indicator == 1) {</u>	<u>=</u>	<u>HARQ-MAP information</u>
<u>Nr of HARQ-MAP</u>	<u>2 bits</u>	<u>Number of HARQ-MAP</u>
<u>For (i = 0; i < Nr. Of HARQ-MAP; i++) {</u>	<u>=</u>	<u>=</u>

<u>Reduced HARQ-MAP()</u>	<i>variable</i>	
}	=	=
}	=	=
<u>Padding</u>	<i>variable</i>	<u>Padding to reach byte boundary</u>
<u>TLV Encoded Information</u>	<i>variable</i>	
}	=	=

The RS-Access-MAP message may include the following parameter encoded as TLV tuples:

HMAC/CMAC Tuple (See 11.1.2.)

Table uuu – Reduced SUB-DL-UL-MAP

<u>Syntax</u>	<u>Size</u>	<u>Notes</u>
<u>Reduced HARQ-MAP() {</u>	=	=
<u>RCID Type</u>	<u>2 bits</u>	<u>“RCID Type” in SUB-DL-UL-MAP</u>
<u>HARQ ACK offset indicator</u>	<u>1 bit</u>	<u>“HARQ ACK offset indicator” in SUB-DL-UL-MAP</u>
<u>If (HARQ ACK offset indicator == 1){</u>	=	=
<u>DL HARQ ACK offset</u>	<u>8 bits</u>	<u>“DL HARQ ACK offset” in SUB-DL-UL-MAP</u>
<u>UL HARQ ACK offset</u>	<u>8 bits</u>	<u>“UL HARQ ACK offset” in SUB-DL-UL-MAP</u>
}	=	=
<u>DL IE count</u>	<u>8 bits</u>	<u>“DL IE count” in SUB-DL-UL-MAP</u>
<u>For (i = 0; i < DL IE count; i++) {</u>	=	=
<u>DL-MAP IE ()</u>	<i>variable</i>	<u>“DL-MAP IE” in SUB-DL-UL-MAP</u>
}	=	=
<u>OFDMA Symbol offset</u>	<u>8 bits</u>	<u>“OFDMA Symbol offset” in SUB-DL-UL-MAP</u>
<u>Subchannel offset</u>	<u>7 bits</u>	<u>“Subchannel offset” in SUB-DL-UL-MAP</u>
<u>UL IE count</u>	<u>8 bits</u>	<u>Number of UL-MAP IE</u>
<u>For (i = 0; i < UL IE count; i++) {</u>	=	=
<u>UL-MAP IE ()</u>	<i>variable</i>	<u>“UL-MAP IE” in SUB-DL-UL-MAP</u>
}		
}	=	=

Table vvv – Reduced HARQ-MAP

<u>Syntax</u>	<u>Size</u>	<u>Notes</u>
<u>Reduced HARQ-MAP() {</u>	=	=
<u>Compact UL MAP appended</u>	<u>1 bit</u>	<u>“Compact UL MAP appended” in HARQ-MAP</u>
<u>DL IE count</u>	<u>6 bits</u>	<u>“DL IE count” in HARQ-MAP</u>
<u>For (n = 0; n < DL IE count; n++) {</u>	=	=
<u>Compact DL-MAP IE()</u>	<i>variable</i>	<u>“Compact DL-MAP IE” in HARQ-MAP</u>
}	=	=
<u>If (Compact UL-MAP appended == 1){</u>	=	=
<u>UL IE count</u>	<u>6 bits</u>	<u>Number of compact UL-MAP IE</u>
<u>For (n = 0; n < UL IE count; n++) {</u>	=	=
<u>Compact UL-MAP IE()</u>	<i>variable</i>	<u>“Compact UL-MAP IE” in HARQ-MAP</u>
}		
}		
}	=	=

6.3.2.3.93 RS Relay MAP (RS-RLY-MAP) message

This message shall be generated by MR-BS for RS with centralized scheduling. This message contains allocation information for RS to transmit in RS relay zone. This message shall be sent once per frame over RS's basic connection in the case of more than 2 hops. After the reception of RS Relay MAP message, RS shall compose R-FCH and R- MAP based on its RS-RLY-MAP message and other related configuration messages.

Table yyy – RS Relay MAP message format

<u>Syntax</u>	<u>Size</u>	<u>Notes</u>
<u>RS_RLY_MAP_Message_Format{</u>	<u>=</u>	<u>=</u>
<u>Management_Message_Type = 99</u>	<u>8 bits</u>	
<u>R_Zone_Prefix_Change_Indication</u>	<u>1 bit</u>	<u>R_Zone_Prefix is used for RS relay zone.</u> <u>0: All the parameters in R_Zone_Prefix remain same with the latest configuration.</u> <u>1: The Parameters in R_Zone_Prefix are updated.</u>
<u>If (R_Zone_Prefix_Change_Indication == 1) {</u>	<u>=</u>	<u>=</u>
<u>R_Zone_Location</u>	<u>7 bits</u>	<u>“R_Zone_Location” in R-FCH</u>
<u>Used_subchannel_bitmap</u>	<u>6 bits</u>	<u>“Used_subchannel_bitmap” in R-FCH</u>
<u>FEC_Code_type_and_modulation_type</u>	<u>5 bits</u>	<u>“FEC_Code_type_and_modulation_type” in R-FCH</u>
<u>Repetition_Coding_Indication</u>	<u>1 bit</u>	<u>“Repetition_Coding_Indication” in R-FCH</u>
<u>}</u>	<u>=</u>	<u>=</u>
<u>DL_IE_count</u>	<u>6 bits</u>	<u>Number of DL-MAP IE</u>
<u>For (i = 0; i < DL_IE_count; i++) {</u>	<u>=</u>	<u>=</u>
<u>DL-MAP_IE ()</u>	<u>variable</u>	<u>“DL-MAP IE” in R-MAP</u>
<u>}</u>	<u>=</u>	<u>=</u>
<u>UL_IE_count</u>	<u>6 bits</u>	<u>Number of UL-MAP IE</u>
<u>For (i = 0; i < UL_IE_count; i++) {</u>	<u>=</u>	<u>=</u>
<u>UL-MAP_IE ()</u>	<u>variable</u>	<u>“UL-MAP IE” in R-MAP</u>
<u>}</u>		
<u>R-link_IE_count</u>	<u>6 bits</u>	
<u>For (i=1; i<= R-link count; i++) {</u>	<u>=</u>	<u>=</u>
<u>R-link_specific_IE ()</u>	<u>variable</u>	<u>“UL-MAP IE” in R-MAP</u>
<u>}</u>	<u>=</u>	<u>=</u>
<u>Padding</u>	<u>variable</u>	<u>Padding to reach byte boundary</u>
<u>TLV_Encoded_Information</u>	<u>variable</u>	
<u>}</u>		

The RS-RLY-MAP message may include the following parameter encoded as TLV tuples:

HMAC/CMAC Tuple (See 11.1.2.)

6.3.28 Messages and Data relaying

6.3.28.1 RS broadcast messages relaying

[Change the following text in line 25 of page 134]

A non-transparent RS shall broadcast FCH, DCD, UCD, DL-MAP and UL-MAP messages in the DL access zone. In addition, a non-transparent RS shall also broadcast R-FCH, DCD, UCD, and R-MAP messages in the DL relay zone in the case of more than two hops., which may be When the messages are generated by the MR-BS, and be sent in the relay zone. The MR-BS should send DCD and UCD messages for RS to broadcast on the access link and relay link with RS primary management CID, and DL-MAP and UL-MAP messages with RS-basis CID to the RS.

Under centralized scheduling, the MR-BS shall generate and send RS-Access-MAP message to RS over RS

basic connection once per frame. When RS receives RS-Access-MAP message, RS shall compose FCH and possibly the associated MAPs such as DL/UL-MAP message, Compressed DL/UL-MAP, SUB-DL-UL-MAPs message and HARQ MAP message, etc., based on the RS-Access-MAP message. If the information to compose DL-MAP and UL-MAP messages is not included in RS-Access-MAP, the MR-BS shall send DL-MAP and UL-MAP messages with RS basic CID to the RS directly. In case of more than two hops, the MR-BS shall generate and send RS-RLY-MAP message to RS over RS basic connection once per frame. When RS receives RS-RLY-MAP message, RS shall compose R-FCH and R-MAP based on the RS_RLY-MAP message.

Upon receiving the DCD/UCD message with RS primary CID, as shown in Figure xxx, the RS shall acknowledge the reception of DCD or UCD messages over primary management connection by sending an acknowledgment header (See 6.3.2.1.2.2.2.3). The Transaction ID of the ACK header shall be set to the Configuration Change Count of DCD or UCD message. There shall be one ACK header per message. The RS may retransmit DCD/UCD message if the acknowledgement header is not received at the expiration of T52 timer.

Under centralized scheduling, as shown in Figure yyy, the RS should request bandwidth on the access link to broadcast the DCD/UCD message with fragmentable broadcast CID.

Under distributed scheduling, the RS shall autonomously broadcast DCD/UCD with fragmentable broadcast CID.

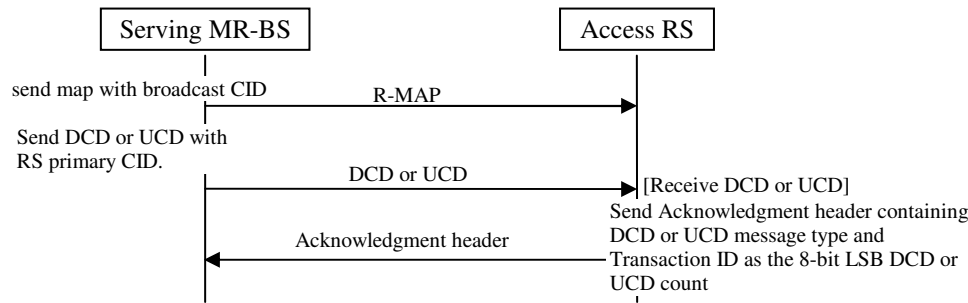

Figure xxx –Relaying DCD/UCD procedure

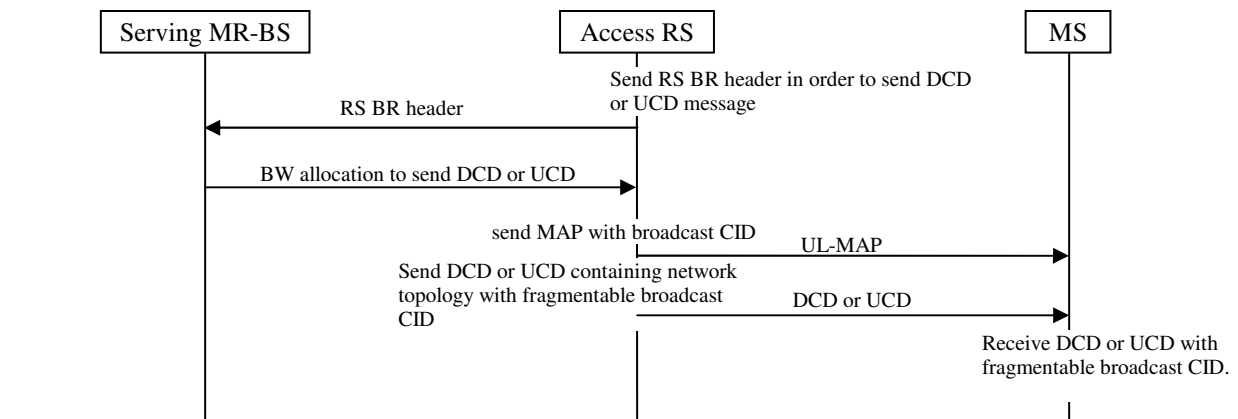

Figure yyy – DCD/UCD broadcasting with centralized scheduling

[Add the following row at the end of table 583 in page 169 as indicated]

Table 583—Parameters and constants

System	Name	Time Reference	Minimum Value	Default value	Maximum value
--------	------	----------------	---------------	---------------	---------------

<u>MR-BS</u>	<u>T52</u>	<u>Waiting for ACK from RS for DCD/UCD messages</u>	<u>TBD</u>	<u>TBD</u>	<u>TBD</u>
--------------	------------	---	------------	------------	------------