

Project	IEEE 802.16 Broadband Wireless Access Working Group < http://ieee802.org/16 >	
Title	Clarification on Cooperative Relaying	
Date Submitted	2007-09-18	
Source(s)	<p>Aik Chindapol, Jimmy Chui, aik.chindapol@siemens.com Adrian Boariu, Shashikant Maheshwari, Haihong Zheng, Yousuf Saifullah, Peter Wang Nokia Siemens Networks</p> <p>Kyu Ha Lee, Young-Jae Kim, Changkyoon Kim Samsung Thales San 14, Nongseo-Dong, Giheung-Gu, Yongin, Gyeonggi-Do, Korea 449-712 Voice: +82-31-280-9917 Fax: +82-31-280-1562 kyuha.lee@samsung.com</p> <p>Byung-Jae Kwak, Sungcheol Chang, D. H. Ahn, Young-il Kim ETRI 161, Gajeong-Dong, Yuseong-Gu, Daejeon, Korea 305-350 Voice: +82-42-860-6618 Fax: +82-42-861-1966 bjkwak@etri.re.kr</p>	
Re:	This is in response for call for comments P802.16j/D1	
Abstract	Clarification on Cooperative Relaying	
Purpose	Review and adopt	
Notice	<i>This document does not represent the agreed views of the IEEE 802.16 Working Group or any of its subgroups. It represents only the views of the participants listed in the "Source(s)" field above. It is offered as a basis for discussion. It is not binding on the contributor(s), who reserve(s) the right to add, amend or withdraw material contained herein.</i>	
Release	The contributor grants a free, irrevocable license to the IEEE to incorporate material contained in this contribution, and any modifications thereof, in the creation of an IEEE Standards publication; to copyright in the IEEE's name any IEEE Standards publication even though it may include portions of this contribution; and at the IEEE's sole discretion to permit others to reproduce in whole or in part the resulting IEEE Standards publication. The contributor also acknowledges and accepts that this contribution may be made public by IEEE 802.16.	
Patent Policy	The contributor is familiar with the IEEE-SA Patent Policy and Procedures: < http://standards.ieee.org/guides/bylaws/sect6-7.html#6 > and < http://standards.ieee.org/guides/opman/sect6.html#6.3 >. Further information is located at < http://standards.ieee.org/board/pat/pat-material.html > and < http://standards.ieee.org/board/pat >.	

Clarification on Cooperative Relaying

NSN, Samsung Thales, ETRI

Introduction

This contribution is a response to comments regarding cooperative relaying and merges RS_CDC-REQ into the RS_CD zone configuration IE (Remedy 1), RS_CD-REQ (Remedy 2) or RS_Config-REQ (Remedy 3) to reduce overhead and to allow per-zone configuration.

Specification changes – Remedy 1

[Remove Section 6.3.2.3.62 and Table 183a]

[Remove the following line from Table 38]

67	RS_CDC_REQ	RS cooperative diversity configuration	Basic
----	------------	--	-------

[Change Table 183zzz in Section 6.3.2.3.73 as follows]

Table 183zzz Zone Configuration IE

Zone Configuration IE Format() {	-	-
Zone Configuration bitmap	8 bits	b0=1, permutation based included b1=1, range of subchannels included b2=1, STC mode b3=1, Cooperative diversity mode configuration included b4=1, AMC mode b5=1, Safety/PAR reduction mode b6-b7: reserved
if (b0 of Zone Configuration bitmap ==1) {		
Permutation based	6 bits	DL PermBase to be used in this zone
Reserved	2 bits	
}	-	-
if (b1 of Zone Configuration bitmap ==1) {	-	-
Min Subchannel index	8 bits	The index of subchannel from which the allocation starts.
Max Subchannel index	8 bits	The index of subchannel at which the allocation ends.
}	-	-
if (b2 of Zone Configuration bitmap ==1) {	-	-
STC mode	TBD	
}	-	-
if (b3 of Zone Configuration bitmap ==1) {	-	-
Cooperative diversity mode	TBD	
Enable cooperative diversity	1 bit	If set to 0, cooperative transmit/hybrid diversity is disabled.
if (Enable cooperative diversity ==1)	=	=
Max Relay Antenna Index	2 bits	Maximum relay antenna index to be used at the relay, MSB first.
for (i=0; i<Max Relay Antenna Index; i++) {	=	=
Antenna assignment for relay antenna i	2 bits	Relay antenna i will transmit as antenna 0, 1, 2, or 3, according to the 2-bit value in this field, MSB first. (Section 8.4.8.10)
}	=	=
Padding	variable	Padding to ensure byte aligned.
}	=	=
}	-	-
if (b4 of Zone Configuration bitmap ==1) {	-	-
AMC mode	TBD	
}	-	-
if (b5 of Zone Configuration bitmap ==1) {	-	-
Safety/PAR reduction mode	TBD	
}	-	-
}	-	-

[Change Section 8.4.8.10 as follows]

8.4.8.10 Cooperative Relaying

Cooperative relaying can be achieved within an MR-cell using either an MR-BS and one or more RSs or multiple RSs transmitting in cooperation. These RSs are either transparent or non-transparent transmitting the same frame start preamble, FCH and MAPs, or non-transparent using a common permutation zone during transmission. It is possible to achieve diversity by sending appropriately coded signals across different MR-BS and RS transmit antennas during the transmission of a burst to subordinate stations. The three modes of operation for cooperative relaying are cooperative source diversity, cooperative transmit diversity, and cooperative hybrid diversity.

For cooperative source diversity, the transmitting antennas simultaneously transmit the same signal using the same time-frequency resource. In cooperative transmit diversity mode, STC-encoded signals are transmitted across the transmitting antennas using the same time-frequency resource (refer to Section 8.4.8 for a list of valid STCs). Cooperative hybrid diversity is a combination of source and transmit diversity.

Cooperative transmit diversity and cooperative hybrid diversity are achieved by the cooperative diversity configuration parameter in the Zone Configuration IE of Table 183zzz. This parameter defines an antenna assignment for each RS antenna for the specified zone. The antenna assignment identifies how the RS shall encode the data, and how the RS shall determine pilots, for the RS antenna. In a STC-DL-Zone with STC not set to "0b00", the RS shall perform local STC encoding locally by using the STC Matrix as defined by STC_DL_Zone_IE (or MIMO DL Basic IE or MIMO DL Enhanced IE or HARQ MAP) as indicated by the assigned antenna number(s) in the Zone Configuration IE for its assigned antenna number(s) as indicated in RS_CDC_REQ, and shall not forward an incorrectly decoded burst to its subordinate stations. The pilot patterns for each RS antenna shall be based on the permutation, the number of antennas as indicated in STC_DL_Zone IE, and the antenna assignment. The antenna assignment will be effective until the next zone configuration message that includes cooperative diversity configuration.

-Figure 323a is an example of local STC encoding at the RS. The STC Encoder is identical to the encoder in Figure 244[Figure 301 in Rev2] of 8.4.8.1.

In cooperative relaying, the frames sent by MR-BS and RS at a given frame time must arrive at the MS within the prefix interval, similar to MDHO.

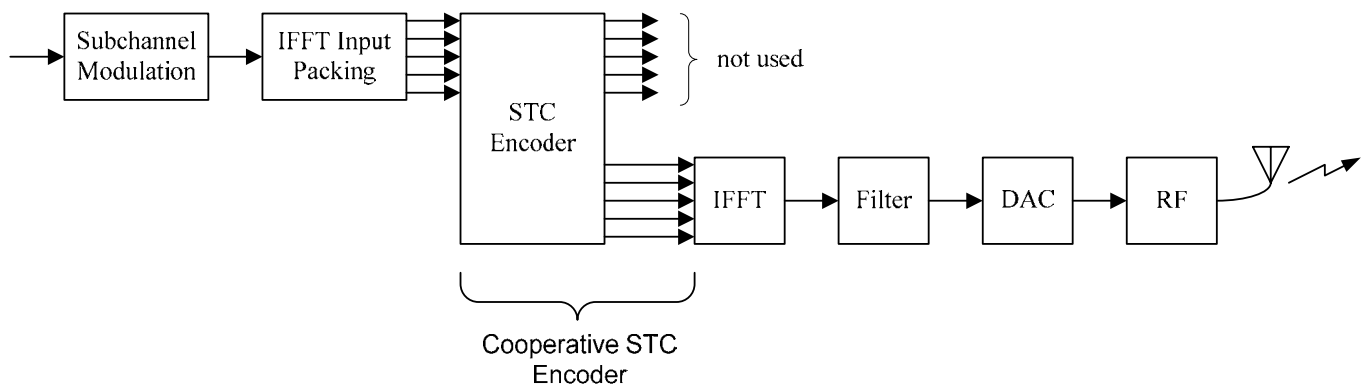

Figure 323a—A logical block example of local STC Encoding at RS. The STC Encoder is identical to the encoder in Figure 244[Figure 301 in Rev2] of Section 8.4.8.1.

Specification changes – Remedy 2

[Remove Section 6.3.2.3.62 and Table 183a]

[Remove the following line from Table 38]

67	RS_CDC_REQ	RS-cooperative-diversity-configuration	Basic
----	------------	--	-------

[Change Table 183n in Section 6.3.2.3.73 as follows]

[Change the row in Table 183n on page 52, lines 16-21 as follows]

Configuration_para_type	8 bits	b0 = 1, Frame Structure-Configuration is included. b1 = 1, R-amble transmission/monitoring parameters are included. b2 – b7: reserved b2 = 1, Cooperative diversity configuration is included. b3 - b7: reserved
-------------------------	--------	--

[Change the rows in Table 183n on page 54, lines 37-44 as follows]

Report Request	1 bit	0:RSSI 1:CINR
}		
<u>If (b2 of Configuration_para_type == 1) {</u>		
<u>Enable_cooperative_diversity</u>	<u>1 bit</u>	<u>If set to 0, cooperative transmit/hybrid diversity is disabled. If set to 1, cooperative transmit/hybrid diversity is enabled, with the following parameters, in STC DL zones where STC is not “0b00” in the corresponding STC_DL_Zone_IE.</u>
<u>if (Enable_cooperative_diversity == 1)</u>	<u>=</u>	<u>=</u>
<u>Max_Relay_Antenna_Index</u>	<u>2 bits</u>	<u>Maximum relay antenna index to be used at the relay, MSB first.</u>
<u>for (i=0; i<Max_Relay_Antenna_Index; i++) {</u>	<u>=</u>	<u>=</u>
<u>Antenna assignment for relay antenna i</u>	<u>2 bits</u>	<u>Relay antenna i will transmit as antenna 0, 1, 2, or 3, according to the 2-bit value in this field, MSB first. (Section 8.4.8.10)</u>
<u>}</u>	<u>=</u>	<u>=</u>
<u>Padding</u>	<u>variable</u>	<u>Padding to ensure byte aligned.</u>
<u>}</u>		
Encoded TLV	variable	
}		

[Change Section 8.4.8.10 as follows]

8.4.8.10 Cooperative Relaying

Cooperative relaying can be achieved within an MR-cell using either an MR-BS and one or more RSs or multiple RSs transmitting in cooperation. These RSs are either transparent or non-transparent transmitting the same frame start preamble, FCH and MAPs, or non-transparent using a common permutation zone during transmission. It is possible to achieve diversity by sending appropriately coded signals across different MR-BS and RS transmit antennas during the transmission of a burst to subordinate stations. The three modes of operation for cooperative relaying are cooperative source diversity, cooperative transmit diversity, and cooperative hybrid diversity.

For cooperative source diversity, the transmitting antennas simultaneously transmit the same signal using the same time-frequency resource. In cooperative transmit diversity mode, STC-encoded signals are transmitted across the transmitting antennas using the same time-frequency resource (refer to Section 8.4.8 for a list of valid STCs). Cooperative hybrid diversity is a combination of source and transmit diversity.

Cooperative transmit diversity and cooperative hybrid diversity are achieved by the cooperative diversity configuration parameter in the RS_CD-REQ message of Table 183n. This parameter defines an antenna assignment for each RS antenna. The antenna assignment identifies how the RS shall encode the data, and how the RS shall determine pilots, for the RS antenna. In a STC DL Zone with STC not set to “0b00”, the RS shall perform local STC encoding locally by using the STC Matrix as defined by STC_DL_Zone_IE (or MIMO DL Basic IE or MIMO DL Enhanced IE or HARQ MAP) as indicated by the assigned antenna number(s) in RS_CD-REQ for its assigned antenna number(s) as indicated in RS_CDC-REQ, and shall not forward an incorrectly decoded burst to its subordinate stations. The pilot patterns for each RS antenna shall be based on the permutation, the number of antennas as indicated in STC_DL_Zone IE, and the antenna assignment. The antenna assignment will be effective until the next RS_CD-REQ message that includes cooperative diversity configuration.

-Figure 323a is an example of local STC encoding at the RS. The STC Encoder is identical to the encoder in Figure 244[Figure 301 in Rev2] of 8.4.8.1.

In cooperative relaying, the frames sent by MR-BS and RS at a given frame time must arrive at the MS within the prefix interval, similar to MDHO.

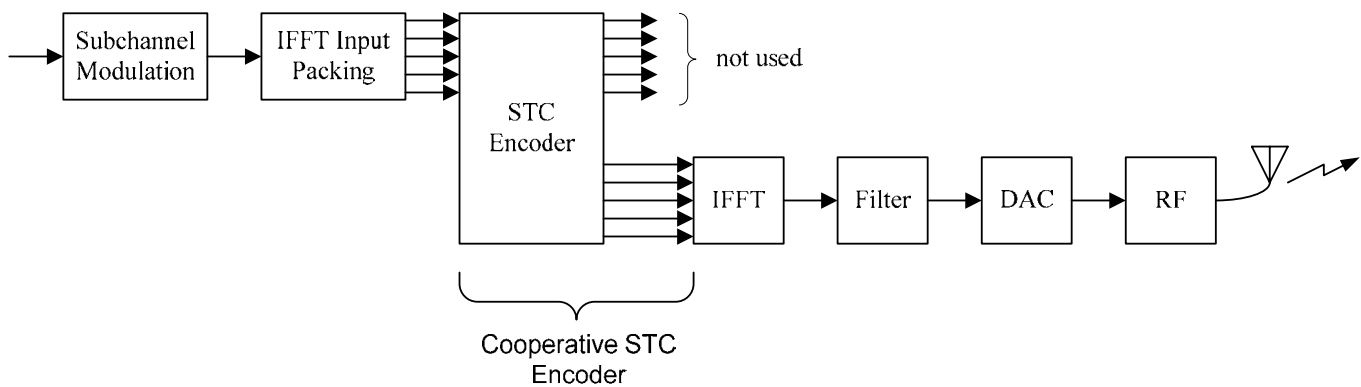

Figure 323a—A logical block example of local STC Encoding at RS. ~~The STC Encoder is identical to the encoder in Figure 244[Figure 301 in Rev2] of Section 8.4.8.1.~~

Specification changes – Remedy 3

[Remove Section 6.3.2.3.62 and Table 183a]

[Remove the following line from Table 38]

67	RS-CDC-REQ	RS cooperative diversity configuration	Basic
----	------------	--	-------

[Change Table 183f in Section 6.3.2.3.67 as follows]

[Change the row in Table 183f on page 42, lines 16-24 as follows]

Configuration_para_type	8 bits	b0 = 1: preamble configuration is included; b1 = 1: remove multicast RSID to disassociate from the RS group; b2 = 1: Unicast RSID is included; b3 = 1: Multicast RSID is included; b4 = 0; Do not transmit preamble; 1: transmit the assigned preamble. b5 = 1: R-amble configuration is included; b6 – b7: reserved b6 = 1: Cooperative diversity configuration is included; b7: reserved
-------------------------	--------	--

[Change the rows in Table 183f on page 44, lines 18-25 as follows]

If (b5 of Configuration_para_type == 1) {		
R-amble_index	8 bits	R-amble index
}		
If (b6 of Configuration_para_type == 1) {		
Enable_cooperative_diversity	1 bit	If set to 0, cooperative transmit/hybrid diversity is disabled. If set to 1, cooperative transmit/hybrid diversity is enabled, with the following parameters, in STC DL zones where STC is not “0b00” in the corresponding STC_DL_Zone_IE.
if (Enable_cooperative_diversity == 1)	=	=
Max_Relay_Antenna_Index	2 bits	Maximum relay antenna index to be used at the relay, MSB first.
for (i=0; i<Max_Relay_Antenna_Index; i++) {	=	=
Antenna_assignment_for_relay_antenna_i	2 bits	Relay antenna i will transmit as antenna 0, 1, 2, or 3, according to the 2-bit value in this field, MSB first. (Section 8.4.8.10)
}	=	=
Padding	variable	Padding to ensure byte aligned.
}		
TLV Encoded Information	variable	TLV specific
}		

[Change Section 8.4.8.10 as follows]

8.4.8.10 Cooperative Relaying

Cooperative relaying can be achieved within an MR-cell using either an MR-BS and one or more RSs or multiple RSs transmitting in cooperation. These RSs are either transparent or non-transparent transmitting the same frame start preamble, FCH and MAPs, [or non-transparent using a common permutation zone during transmission](#). It is possible to achieve diversity by sending appropriately coded signals across different MR-BS and RS transmit antennas during the transmission of a burst to subordinate stations. The three modes of operation for cooperative relaying are cooperative source diversity, cooperative transmit diversity, and cooperative hybrid diversity.

For cooperative source diversity, the transmitting antennas simultaneously transmit the same signal using the same time-frequency resource. In cooperative transmit diversity mode, STC-encoded signals are transmitted across the transmitting antennas using the same

time-frequency resource (refer to Section 8.4.8 for a list of valid STCs). Cooperative hybrid diversity is a combination of source and transmit diversity.

Cooperative transmit diversity and cooperative hybrid diversity are achieved by the cooperative diversity configuration parameter in the RS_Config-REQ message of Table 183f. This parameter defines an antenna assignment for each RS antenna. The antenna assignment identifies how the RS shall encode the data, and how the RS shall determine pilots, for the RS antenna. In a STC DL Zone with STC not set to “0b00”, the RS shall perform local STC encoding locally by using the STC Matrix as defined by STC_DL_Zone_IE (or MIMO DL Basic IE or MIMO DL Enhanced IE or HARQ MAP) as indicated by the assigned antenna number(s) in RS_Config-REQ for its assigned antenna number(s) as indicated in RS_CDC-REQ, and shall not forward an incorrectly decoded burst to its subordinate stations. The pilot patterns for each RS antenna shall be based on the permutation, the number of antennas as indicated in STC_DL_Zone IE, and the antenna assignment. The antenna assignment will be effective until the next RS_Config-REQ message that includes cooperative diversity configuration.

-Figure 323a is an example of local STC encoding at the RS. The STC Encoder is identical to the encoder in Figure 244[Figure 301 in Rev2] of 8.4.8.1.

In cooperative relaying, the frames sent by MR-BS and RS at a given frame time must arrive at the MS within the prefix interval, similar to MDHO.

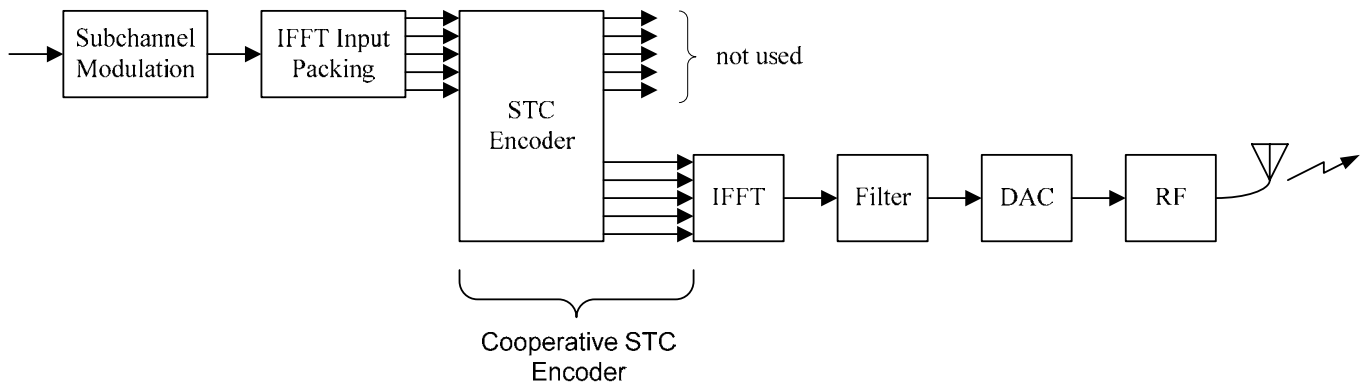

Figure 323a—A logical block example of local STC Encoding at RS. ~~The STC Encoder is identical to the encoder in Figure 244[Figure 301 in Rev2] of Section 8.4.8.1.~~