

Connection Identification and Transmission for Relay Support

IEEE 802.16 Presentation Submission Template (Rev. 8.3)

Document Number:

IEEE C80216j-06/170r2

Date Submitted:

2006-11-16

Source:

Tzu-Ming Lin, Wern-Ho Sheen, Fang-Ching Ren, Jen-Shun Yang,
Chie Ming Chou, I-Kang Fu, Ching-Tarnng Hsieh
Industrial Technology Research Institute (ITRI)/
National Chiao Tung University (NCTU), Taiwan
195 Sec. 4, Chung Hsing Rd.
Chutung, Hsinchu, Taiwan 310, R.O.C.

Voice: +886-3-591-6020

Fax: +886-3-582-0371

E-mail: tmlin@itri.org.tw

Venue:

IEEE 802.16 Session#46, Dallas, TX, USA

Base Document:

None

Purpose:

Contribution

Notice:

This document has been prepared to assist IEEE 802.16. It is offered as a basis for discussion and is not binding on the contributing individual(s) or organization(s). The material in this document is subject to change in form and content after further study. The contributor(s) reserve(s) the right to add, amend or withdraw material contained herein.

Release:

The contributor grants a free, irrevocable license to the IEEE to incorporate material contained in this contribution, and any modifications thereof, in the creation of an IEEE Standards publication; to copyright in the IEEE's name any IEEE Standards publication even though it may include portions of this contribution; and at the IEEE's sole discretion to permit others to reproduce in whole or in part the resulting IEEE Standards publication. The contributor also acknowledges and accepts that this contribution may be made public by IEEE 802.16.

IEEE 802.16 Patent Policy:

The contributor is familiar with the IEEE 802.16 Patent Policy and Procedures <<http://ieee802.org/16/ipr/patents/policy.html>>, including the statement "IEEE standards may include the known use of patent(s), including patent applications, provided the IEEE receives assurance from the patent holder or applicant with respect to patents essential for compliance with both mandatory and optional portions of the standard." Early disclosure to the Working Group of patent information that might be relevant to the standard is essential to reduce the possibility for delays in the development process and increase the likelihood that the draft publication will be approved for publication. Please notify the Chair <<mailto:chair@wirelessman.org>> as early as possible, in written or electronic form, if patented technology (or technology under patent application) might be incorporated into a draft standard being developed within the IEEE 802.16 Working Group. The Chair will disclose this notification via the IEEE 802.16 web site <<http://ieee802.org/16/ipr/patents/notices>>.

Problem Definition

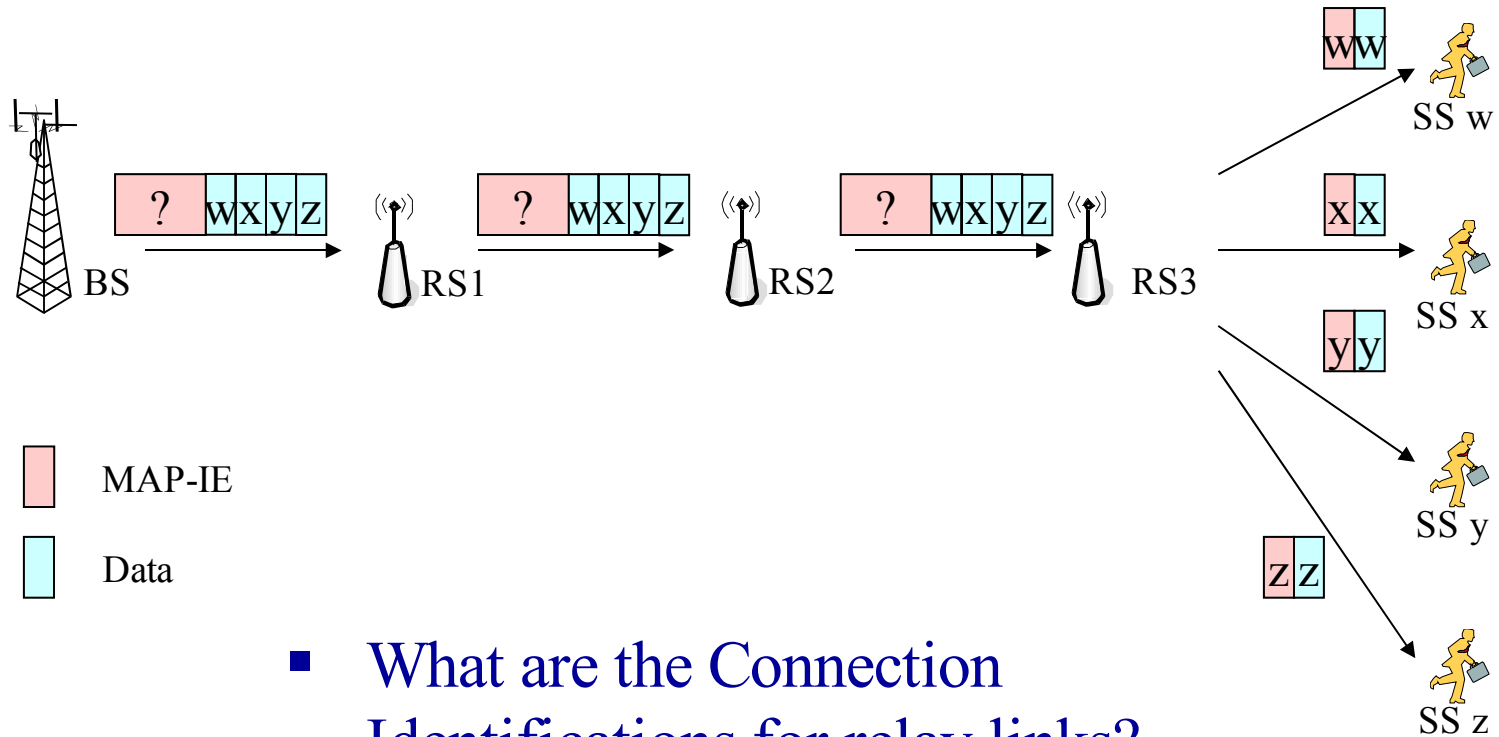

- What are the Connection Identifications for relay links?
- How can each RS relay the burst toward the destination SS?

Relay path oriented relaying

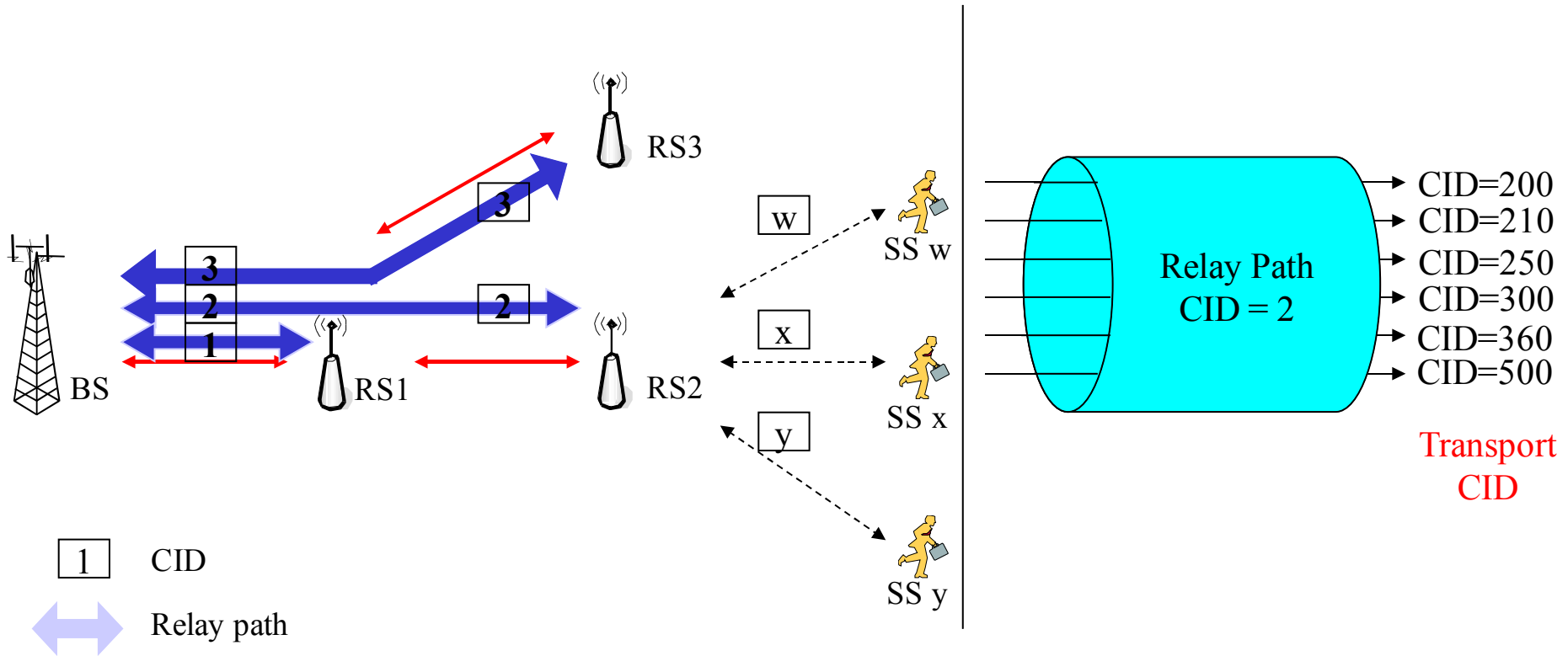

- Connections are identified by relay path CID over relay links
- RS only records the relay path CIDs of subordinate RSs
- MR-BS grants resource per relay path

Proposed Solution – One relay path case

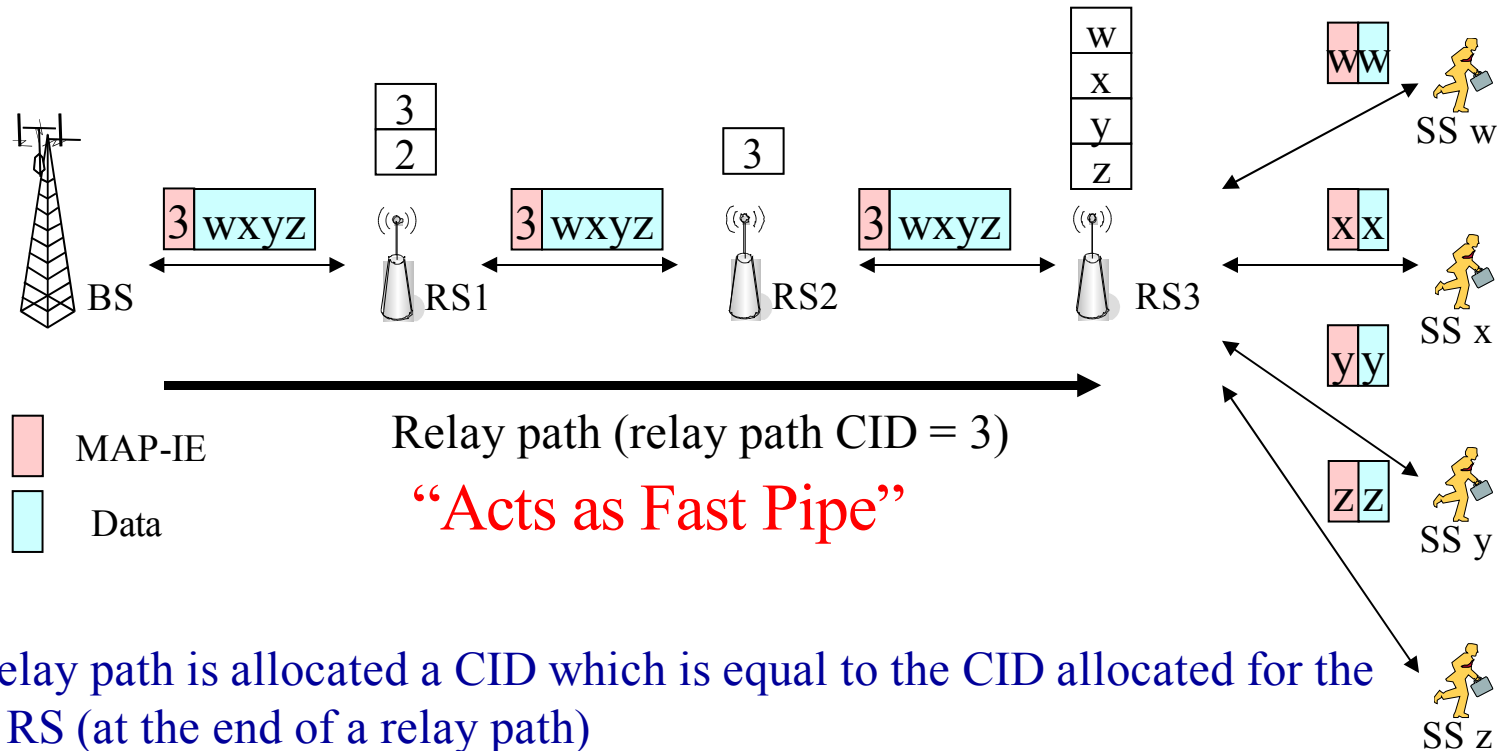

- Each relay path is allocated a CID which is equal to the CID allocated for the access RS (at the end of a relay path)
- Each RS should maintain a relay path routing table, so when a burst relaying along the relay path, each RS should check DL-MAP to see whether belonging to its subordinate RS or served SS, or it shall omit this burst.
- Relay Path shall not be aware of service flow classifications.

Proposed Solution – Multiple Relay path case

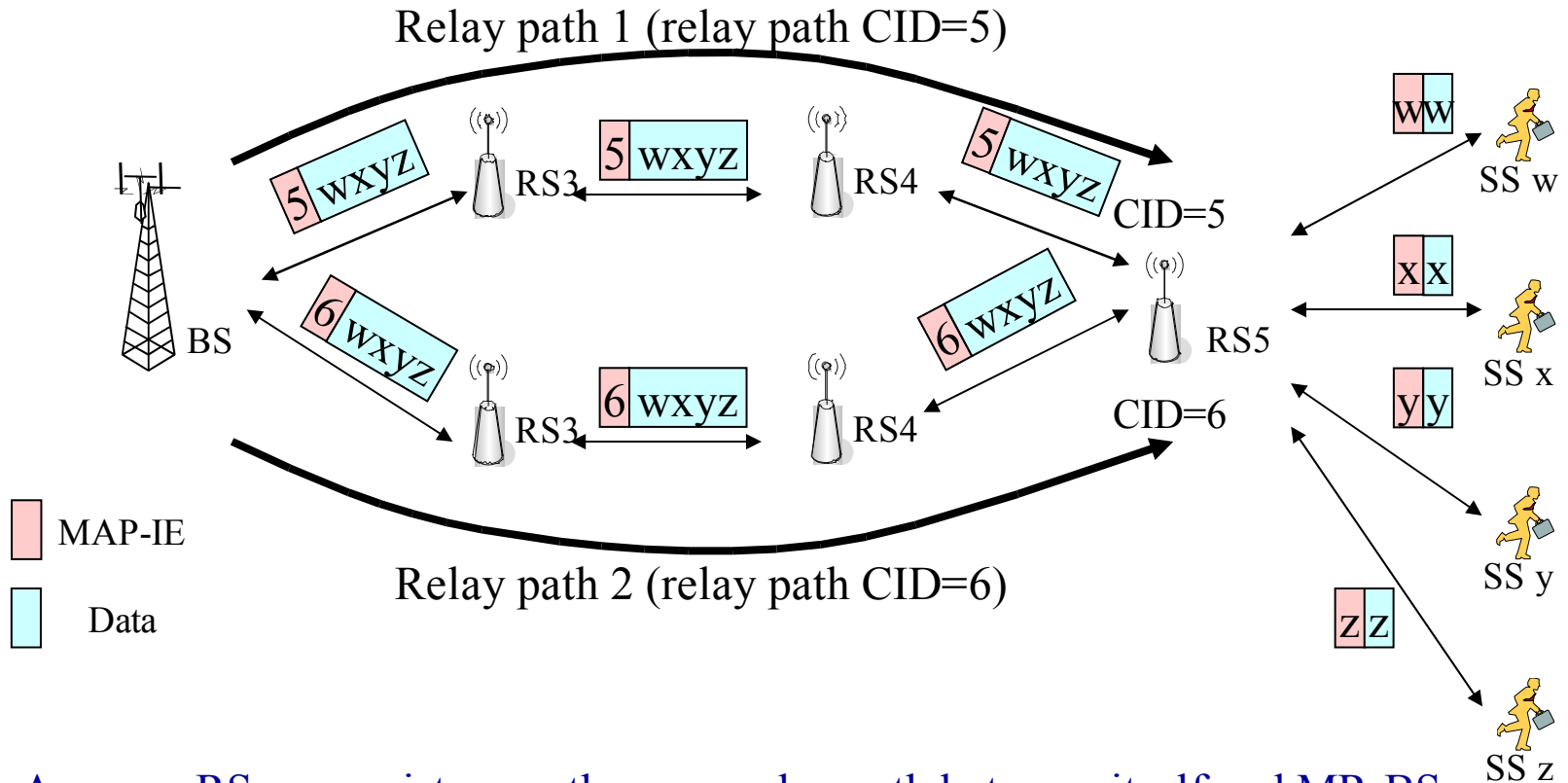

- A access RS may exist more than one relay path between itself and MR-BS.
- Each relay path should assigned a Relay path CID taking from the destination RS's CIDs.

Proposed Solution – Example of Real Deployment

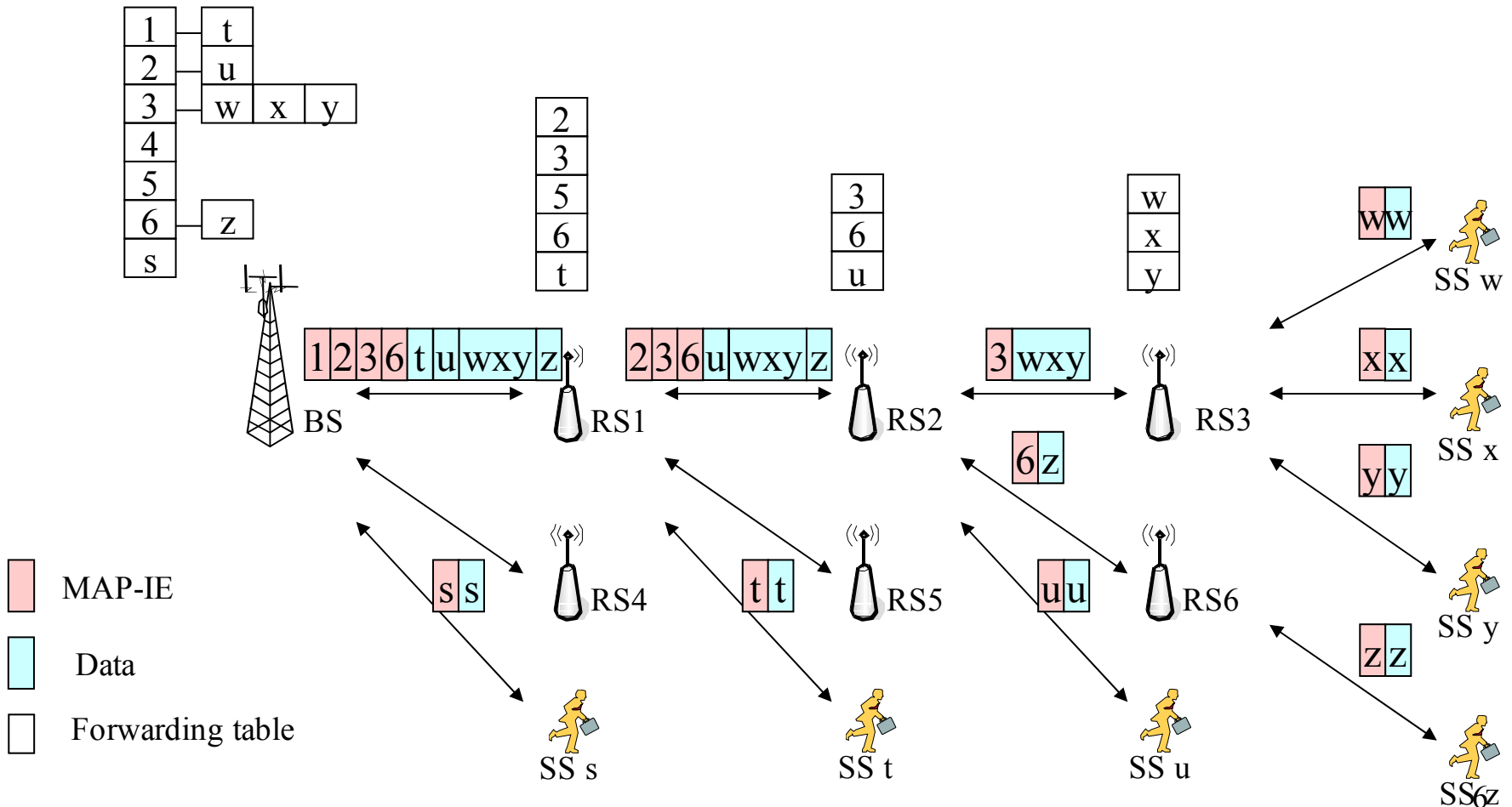

Summary

- Proposed a relay path oriented relaying scheme
- Advantages:
 - Simple and backward compatibility
 - No new addressing field defined in Generic MAC header
 - Relay path acts as a fast pipe, and SFID assignment and QoS negotiation remain the legacy way.
 - Relaying Efficiently
 - No burst process (MPDU process and/or CID translation) is needed in RS
 - Support multi-path relaying (with the same MR-BS and destination RS)
 - Support mobility
 - MS handover: only update the relay path routing tables in the old and new paths' access RSs.
 - MRS handover: only update the relay path routing tables of the RSs within both the old and new paths.
- Disadvantage:
 - Relay path routing table lookup may be the burden

Proposed Text

- [Add the following subclause and text in terminology]
- **relay path connection**: a unidirectional mapping between base station (BS) and relay station (RS) medium access control (MAC) peers for the purpose of transporting relay service traffic. Relay path connection is identification by relay path connection identification (Relay CID). All SS traffic within the RS is carried on a relay path connection. *See also: relay path connection identifier*
- **relay path connection identification (Relay CID)**: A 16 bit value that identifies a relay path connection to equivalent peers in the MAC of the base station (BS) and relay station (RS). It maps to a relay service, which includes the services flows associated with the subscribe stations (SS) that served by the RS.
- **relay path management connection identification (Relay Management CID)**: A 16 bits value that identifies a relay path management connection to equivalent peers in the MAC of the base station (BS) and relay station (RS). Each intermediate RS along the relay path could decode the MPDU for path management purposes.

Proposed Text

- [Add the following subclause and text in 6.3.1.3 Addressing and connection for relay support]
 - Each air interface in RS could also have 48-bit universal MAC address, as defined in IEEE STD 802-2001. This address uniquely defines the air interface of the RS. It is used during the initial ranging process to establish the appropriate connections for RS. It is also used as part of the authentication process by which the MR-BS and RS can identify each other.
 - At RS initialization, two pairs of relay path connections (uplink and downlink) shall be established between the MR-BS and the RS and identified by the same Relay CID. The two pairs of relay path connections reflect the fact that there are only one relay traffic between an RS and the MR-BS for each direction. The relay path connection is used by MR-BS and RS to exchange the control and data traffic of the RS and the SSs served by the RS.
 - The CIDs for the relay path connections shall be assigned in the RNG-RSP and REG-RSP messages. The message dialogs provides two CID values. The same CID value is assigned to both uplink and downlink of each relay connection pair.
 - For bearer services in relay path connection, the setup and registration is identical to 6.3.1.1. When admitted or active, the service flows with common relay path are uniquely associated with the combination of relay path connection and transport connections. For relay services of the RS, all the bearer or data services shall be transferred in a relay path connection along the path from MR-BS to the RS.

Proposed Text

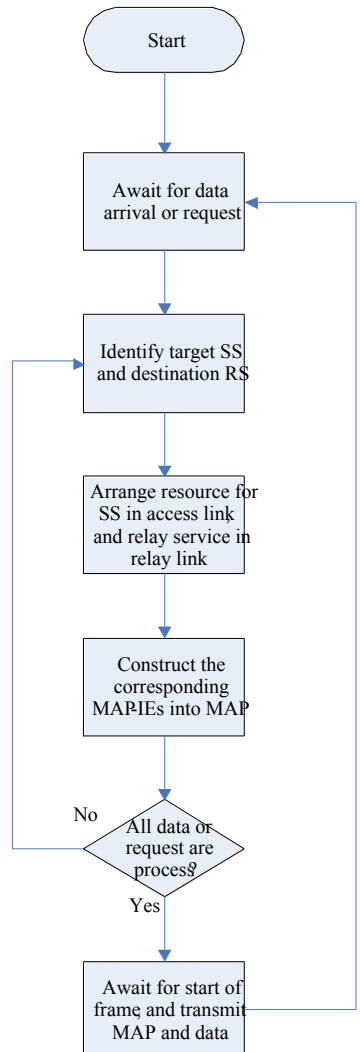

Figure xxx – Relay Service Flow Chart of MR-BS

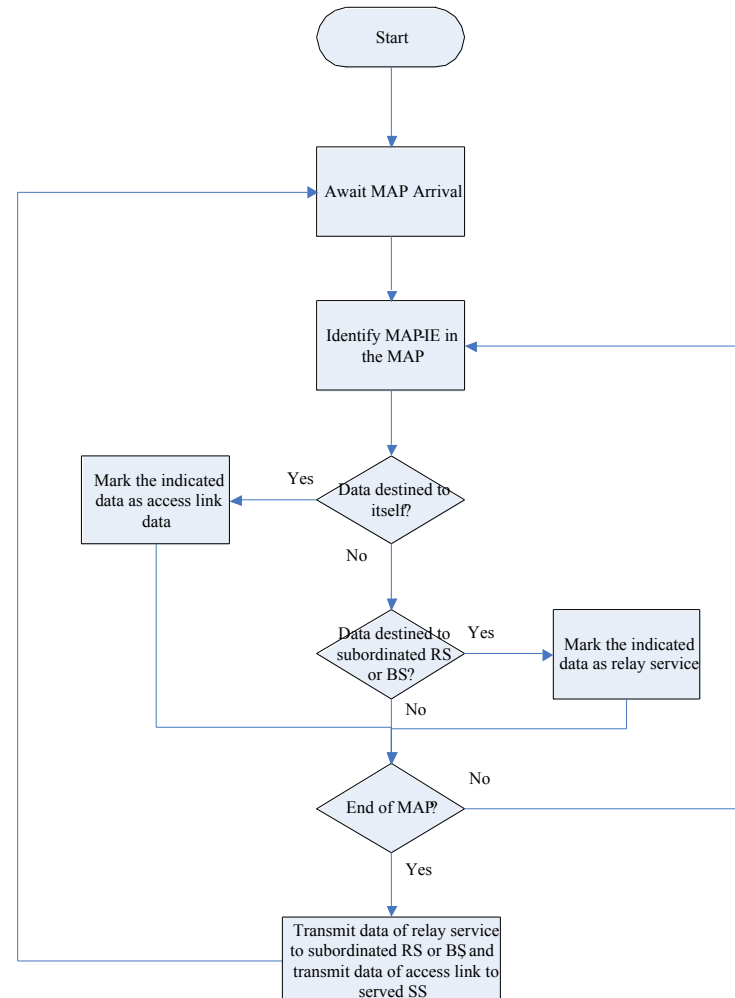

Figure xxx – Relay Service Flow Chart of RS

Proposed Text

▪ *Change Table 345—CIDs as*

<i>indicated:</i>	Value	Description
Initial ranging	0x0000	Used by SS and MR-BS during initial ranging process
Basic CID <u>and Relay CID</u>	0x0001 – m	The same value is assign to both the DL and UL connection. <u>Relay CID is used by RS and MR-BS for downlink or uplink relay.</u>
Primary management and Relay <u>Management CID</u>	m+1 – 2m	<u>Used for relay path connection management, the same value is assign to both the DL and UL connection.</u> The same value is assign to both the DL and UL connection
Transport CIDs and Secondary Mgt CIDs	2m+1 – 0xFE9F	For the secondary management connection, the same value is assign to both the DL and UL connection.
Multicast CIDs	0xFEA0 – 0xFEFE	A BS supporting AAS shall use this CIS when allocating an AAS Ranging period (using AAS Ranging Allocation IE)
AAS initial ranging CID	0xFEFF	A MR-BS supporting AAS shall use this CID when allocating a Initial Ranging period for AAS devices
Multicast polling CIDs	0xFF00 – 0xFFF9	An SS may be included in one or more multicast polling groups for the purposes of obtaining bandwidth via polling. These connections have no associated service flow.
Normal mode multicast CID	0xFFFFA	Used in DL-MAP to denote bursts for transmission of DL broadcast information to normal mode MS.
Sleep mode multicast CID	0xFFFFB	Used in DL-MAP to denote bursts for transmission of DL broadcast information to Sleep mode MS. May also be used in MOB_TRF-IND messages.
Idle mode multicast CID	0xFFFFC	Used in DL-MAP to denote bursts for transmission of DL broadcast information to Idle mode MS. May also be used in MOB_PAG-ADV messages.
Fragmentable Broad- cast CID	0xFFFFD	Used by the BS for transmission of management broadcast information with fragmentation. The fragment sub header shall use 11-bit long FSN on this connection.
Padding CID	0xFFFFE	Used for transmission of padding information by SS and MR-BS
Broadcast CID	0xFFFFF	Used for broadcast information that is transmitted on a downlink to all SS.

Appendix: Comparison and Analysis

Criteria

- Processed CIDs in MAP
 - RS should process CIDs in MAP sent from MR-BS to identify the data for further forwarding
 - This presents the CIDs processed by each RS in MAP
- CID entries in RS
 - Each RS would maintain a CID table to identify the received data and see if it needs to relay the data or not.
 - This presents the CIDs that RS shall maintain.

Case 1 - Two-hop relay network (degree 1)

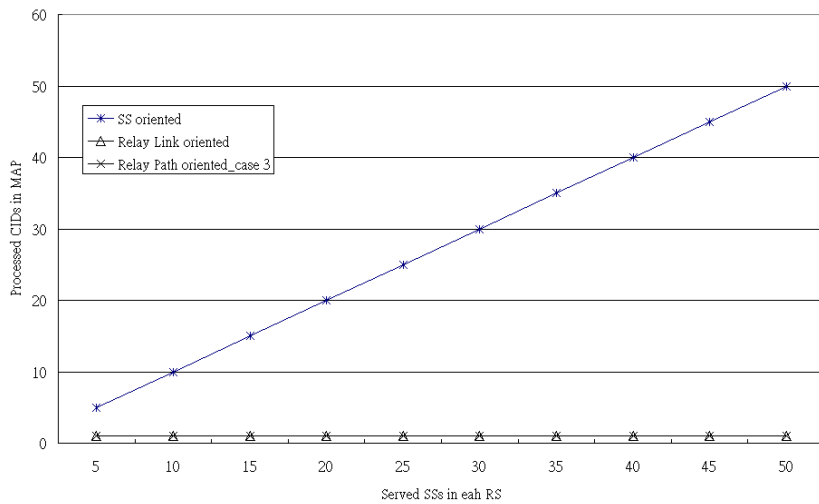
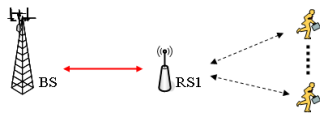

Processed CID in MAP

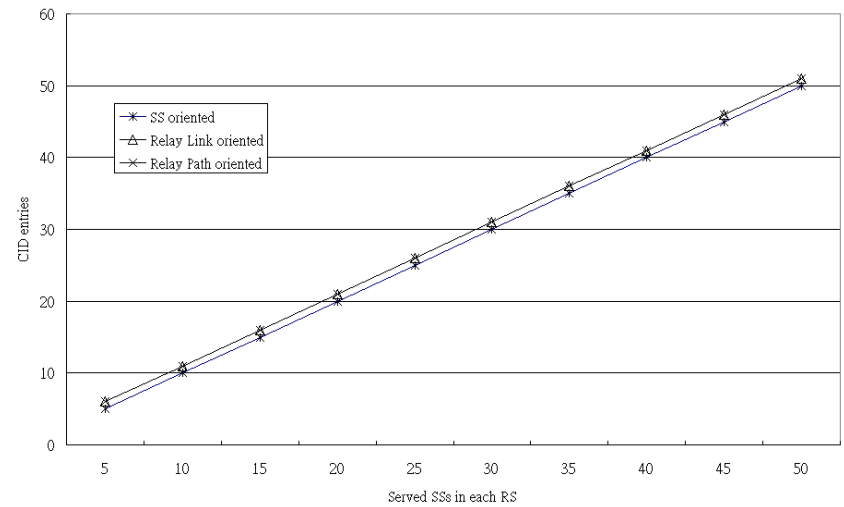

CID entries in RS

Case 2 - Two-hop relay network (degree 3)

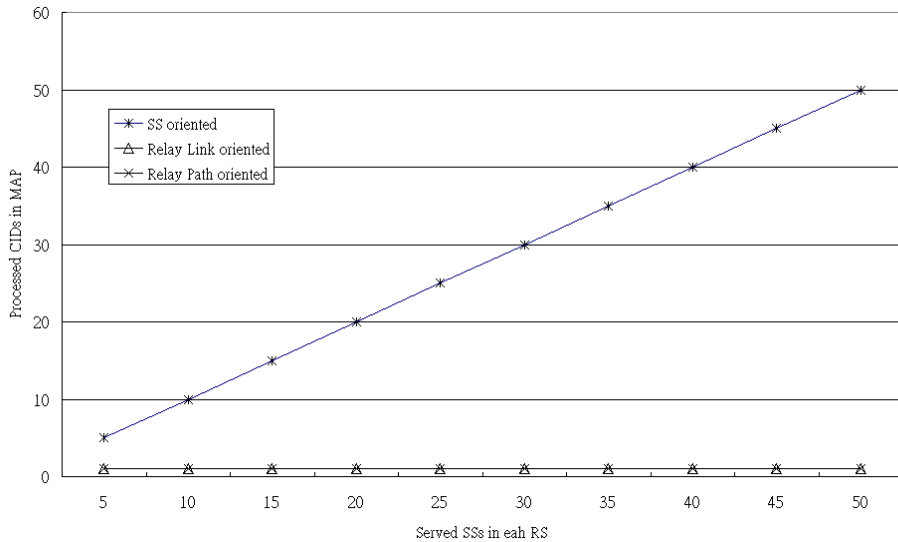
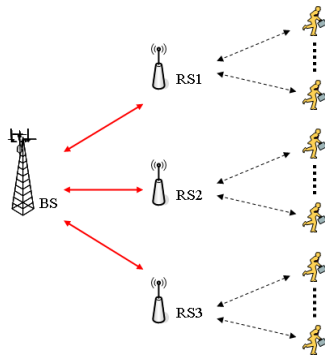

Processed CID in MAP

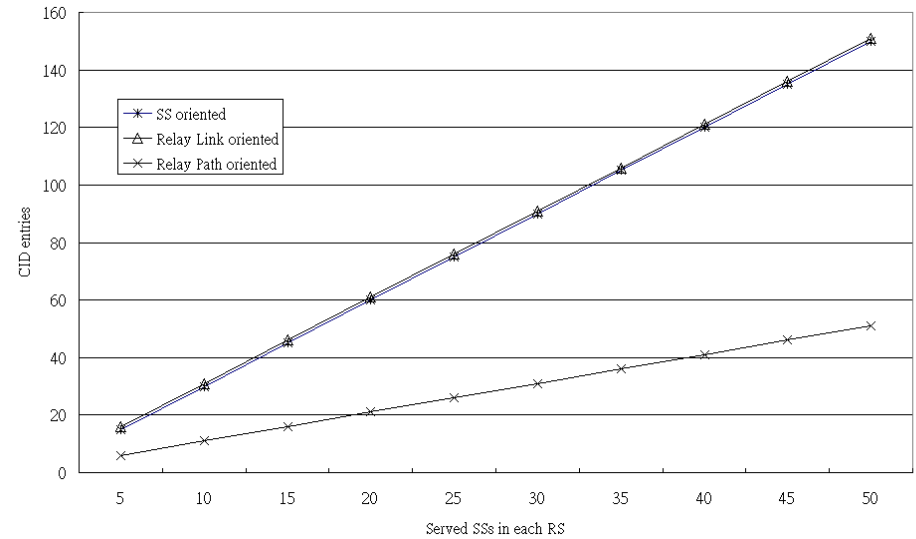

CID entries in RS

Case 3 - Three-hop relay network (degree 3)

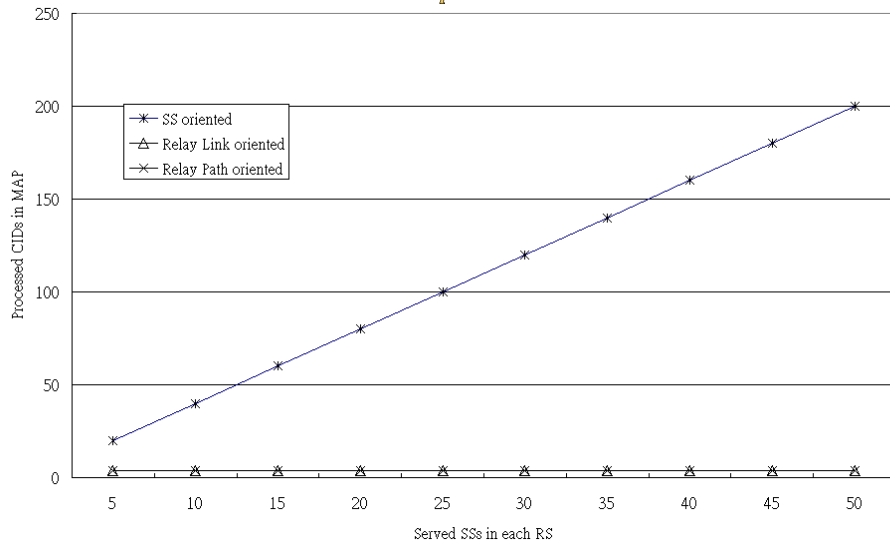
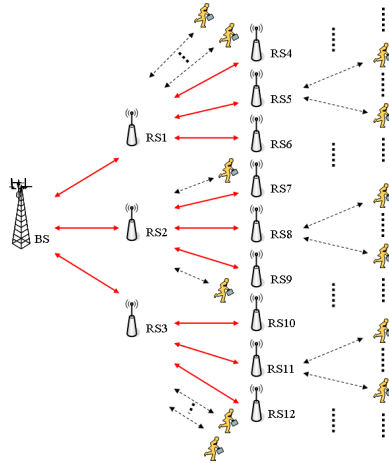

Processed CID in MAP

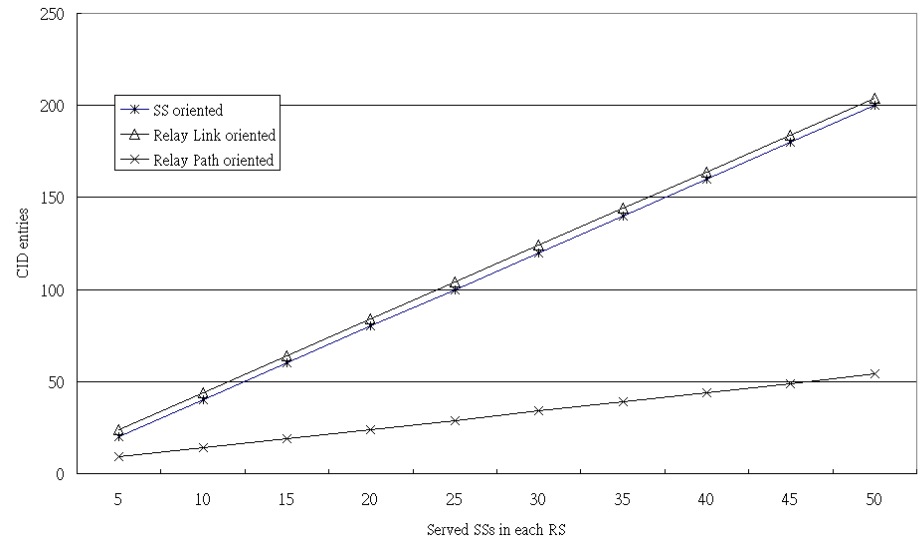

CID entries in RS

Comparison

- Burst processing overhead
 - Relay link oriented scheme shall process the received burst for further forwarding
 - CID translation is needed
 - Relay path oriented scheme only check the relay path CID
- Management overhead
 - MR-BS requests each RS along the relay path to update the CID table when each MS enter or leave the cell in relay link oriented scheme
 - Intermediate RS shall not be aware of the leaving or entering of MS served by last RS in relay path oriented scheme

Comparison

	SS oriented	Relay Link oriented	Relay Path oriented	
System Resource	2 (MAC Addr. + RS CID)	3 (MAC Addr. + Relay Link CID + RS CID)	2 (MAC Addr. + Relay Path CID)	
Radio Resource	$O(M*N)$	$O(1)$	$O(N)$	
RS Complexity	Processed CIDs for relay transmission in RS (Rx)	$O(1)$	$O(N)$	
	Processed CIDs for relay transmission in RS (Tx)	$O(M*N)$	$O(N)$	
	Data processing during relaying	N/A	$O(M*N)$	N/A
	CID table maintenance in each RS	$O(M*N)$	$O(M*N)$	$O(N+M)$

H : Hop counts

M : Average number of SSs served by RS

N : Number of relay path (= number of RS)

$M \gg N > H$

