

[Group Handover on the Mobile RS]

IEEE 802.16 Presentation Submission Template (Rev. 8.3)

Document Number:

IEEE S802.16j-06/227

Date Submitted:

2006-11-15

Source:

Sungkyung Kim, Sungcheol Chang, Chulsik Yoon

ETRI

161 Gajeon-dong, Yuseong-gu, Daejeon, KOREA

Voice:

+82-42-860-6448

Fax:

+82-42-861-1996

E-mail:

cyrano@etri.re.kr

Venue:

Session #46; Dallas, TX, USA.

Base Document:

IEEE C802.16j-06_027.doc

Purpose:

This contribution proposes group handover procedure on the mobile RS.

Notice:

This document has been prepared to assist IEEE 802.16. It is offered as a basis for discussion and is not binding on the contributing individual(s) or organization(s). The material in this document is subject to change in form and content after further study. The contributor(s) reserve(s) the right to add, amend or withdraw material contained herein.

Release:

The contributor grants a free, irrevocable license to the IEEE to incorporate material contained in this contribution, and any modifications thereof, in the creation of an IEEE Standards publication; to copyright in the IEEE's name any IEEE Standards publication even though it may include portions of this contribution; and at the IEEE's sole discretion to permit others to reproduce in whole or in part the resulting IEEE Standards publication. The contributor also acknowledges and accepts that this contribution may be made public by IEEE 802.16.

IEEE 802.16 Patent Policy:

The contributor is familiar with the IEEE 802.16 Patent Policy and Procedures <<http://ieee802.org/16/ipr/patents/policy.html>>, including the statement "IEEE standards may include the known use of patent(s), including patent applications, provided the IEEE receives assurance from the patent holder or applicant with respect to patents essential for compliance with both mandatory and optional portions of the standard." Early disclosure to the Working Group of patent information that might be relevant to the standard is essential to reduce the possibility for delays in the development process and increase the likelihood that the draft publication will be approved for publication. Please notify the Chair <<mailto:chair@wirelessman.org>> as early as possible, in written or electronic form, if patented technology (or technology under patent application) might be incorporated into a draft standard being developed within the IEEE 802.16 Working Group. The Chair will disclose this notification via the IEEE 802.16 web site <<http://ieee802.org/16/ipr/patents/notices>>.

Introduction

- This contribution proposes handover schemes for mobile relay network.
- Transmission path between MR-BS and MS riding on a vehicle
 - Both direct link and relay link available.
 - Only relay link provided by an MRS available.

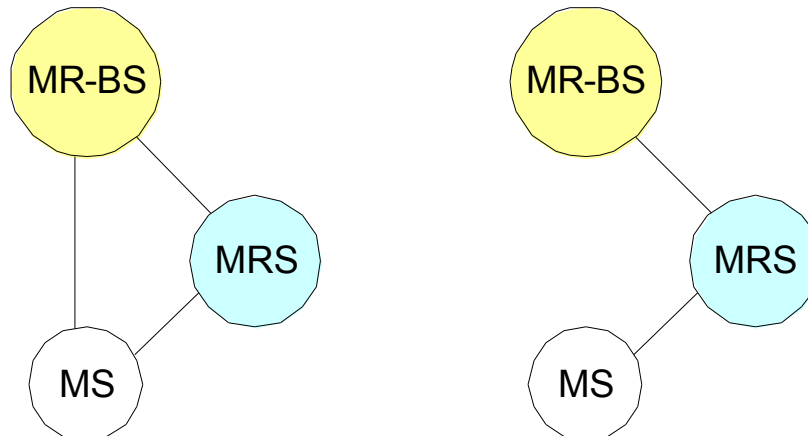
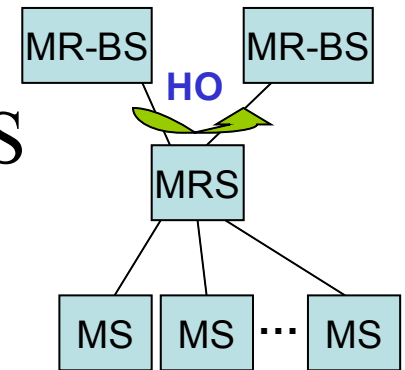

Motivation

- When an MRS moves, it also generates handovers of all the MS served through the relay link.
- Using the existing MOB_xxHO messages with small changes, the MRS handover itself can be easily performed.
- However, in case that there are many MS attached to the MRS,
 - According to the IEEE 802.16e specifications, the congestion on the radio link may occur due to trials of many handover executions.
 - If MRS performs handover earlier than MS, some discontinuations of communication or large access delay may occur.
- It is necessary for MSR to control MS handover
→ **Group Handover** on the MRS.

Group HO on the MRS

- Both an MR-BS and an MRS should maintain a list of MS which are served through the relay link.
- The operation of Group HO consists of two steps:
 - Negotiation with MR-BS through Group HO messages
 - Negotiation with MSs through MOB HO messages
- During a Group HO, a mobile RS may relay or boost up signals of the target MR-BS as well as the serving MR-BS in order to derive MS handover.

Group Handover Procedure

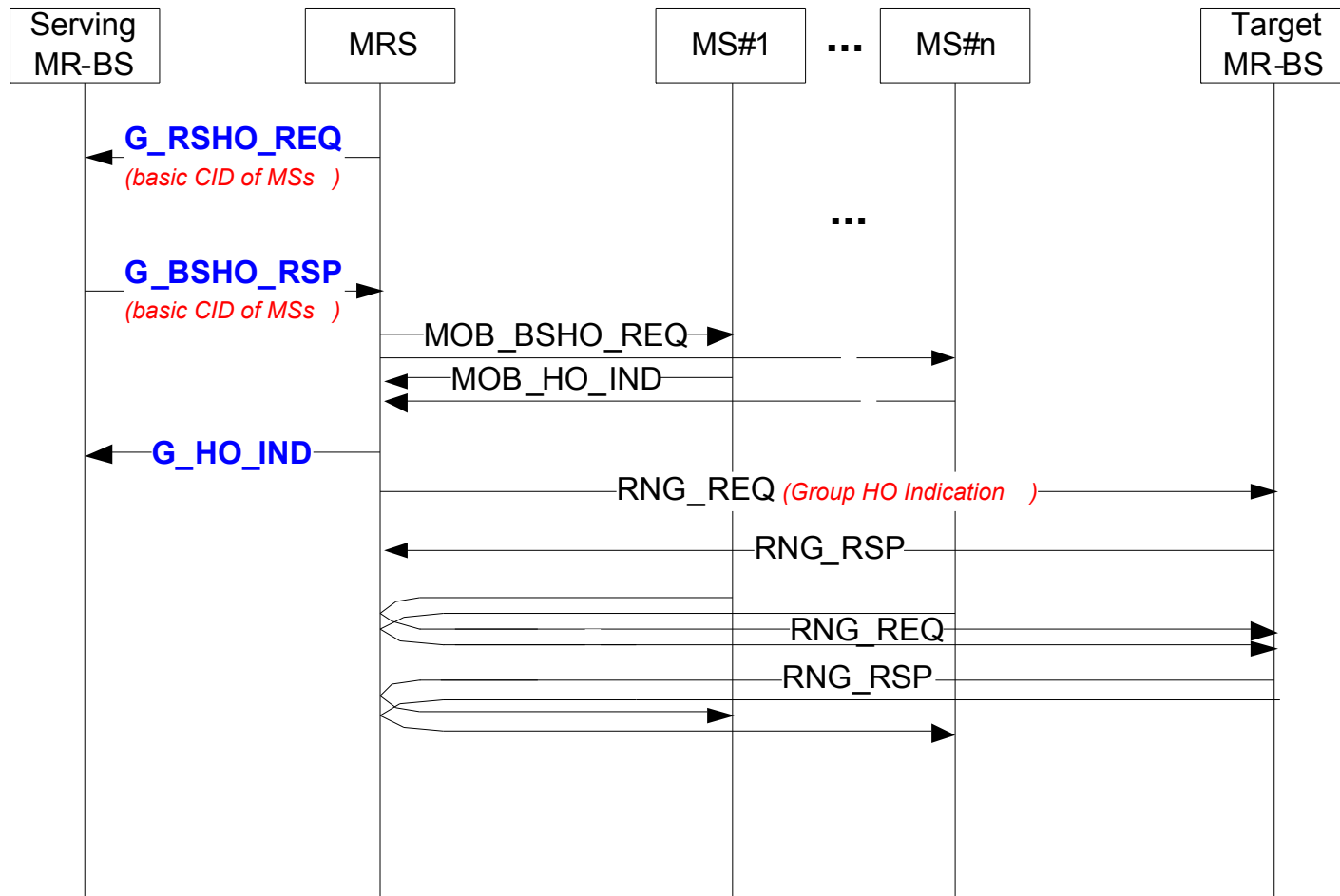

Conclusion

- Contribution provides text for
 - Group HO for MS and mobile RS.
 - New messages needed between MR-BS and MRS.
- Advantages of Group HO are
 - Bandwidth efficiency.
 - Avoidance of large access delay of MS during the HO.
 - Fast and Controllable HO.
 - Backward-compatibility in MS behavior.
- More details and proposed text proposals are in C80216j-06_227.doc