

Project	<b>IEEE 802.16 Broadband Wireless Access Working Group</b>
Title	<b>Amber proposal for 802.16 MAC layer</b>
Date Submitted	1999-10-28
Source	<p><b>Yigal Leiba</b>  <b>AMBER</b>  <b>Hashahaf 8 St.</b>  <b>Holon 58808</b>  <b>ISRAEL</b></p> <p>Voice: +972-3-5587628  Fax:  E-mail:yigalle@yahoo.com</p>
Re:	Response to a Call for Contributions session #4 , 802.16 MAC layer, from Sep. 22
Abstract	This document is a draft specification of a MA/CA (multiple access collision avoidance) based MAC, with enhanced scalability, efficiency and support of QoS. The MAC has several points in common with the 802.11 standard MAC layer.
Purpose	Adoption of this draft as the basis for the broadband wireless access MAC
Notice	This document has been prepared to assist the IEEE 802.16. It is offered as a basis for discussion and is not binding on the contributing individual(s) or organization(s). The material in this document is subject to change in form and content after further study. The contributor(s) reserve(s) the right to add, amend or withdraw material contained herein.
Release	The contributor acknowledges and accepts that this contribution may be made public by 802.16.
IEEE Patent Policy	<p>The contributor is familiar with the IEEE Patent Policy, which is set forth in the IEEE-SA Standards Board Bylaws &lt;<a href="http://standards.ieee.org/guides/bylaws">http://standards.ieee.org/guides/bylaws</a>&gt; and includes the statement:</p> <p>“IEEE standards may include the known use of patent(s), including patent applications, if there is technical justification in the opinion of the standards-developing committee and provided the IEEE receives assurance from the patent holder that it will license applicants under reasonable terms and conditions for the purpose of implementing the standard.”</p>

# **AMBER proposal for 802.16 MAC layer**

*Author: Yigal Laibe*

## TABLE OF CONTENTS:

<b>1.</b>	<b>OVERVIEW.....</b>	<b>3</b>
<b>2.</b>	<b>REFERENCE MODEL.....</b>	<b>4</b>
<b>3.</b>	<b>MAC SERVICE DEFINITION.....</b>	<b>5</b>
3.1.	ASYNCHRONOUS DATA SERVICE.....	5
3.2.	SYNCHRONOUS DATA SERVICE.....	5
3.3.	MSDU ORDERING.....	5
3.4.	SECURITY SERVICES.....	5
<b>4.</b>	<b>FRAME FORMAT.....</b>	<b>6</b>
4.5.	GENERAL FRAME FORMAT.....	6
<b>5.</b>	<b>MAC SUB-LAYER FUNCTIONAL DESCRIPTION.....</b>	<b>7</b>
5.6.	TIME SLOTS.....	7
5.7.	DOWNSTREAM TRAFFIC.....	7
5.8.	UPSTREAM TRAFFIC.....	7
5.8.1.	<i>Reservation based access</i> .....	7
5.8.2.	<i>Contention based access</i> .....	8
5.9.	SYNCHRONIZATION.....	9
5.10.	BANDWIDTH ALLOCATION.....	9
5.11.	PROTOCOL CONTROL.....	9
5.12.	MAC LAYER MANAGEMENT.....	9
5.13.	EXTENSION FOR THE FDD CASE.....	10
<b>6.</b>	<b>EXISTING STANDARDS.....</b>	<b>11</b>
<b>7.</b>	<b>BENEFITS.....</b>	<b>11</b>

## Overview

This document describes a proposal for the MAC layer of the 802.16, in accordance with the "Development Plan for the 802.16.1 Air Interface Standard" (Document [IEEE 802.16-99/05](#)).

The proposed MAC is intended for a packet oriented PHY with TDD duplexing mode. The same MAC with slight modifications can be used in FDD duplexing mode. The multiple access method in the upstream direction is an enhanced version of the collision avoidance method used in the 802.11 standard MAC layer. The MAC highlights are,

- Bandwidth in both downstream and upstream directions is controlled by the BST modem to allow QoS support
- Upstream multiple access method allows both contention and reservation-based data transmission
- TDD mode of operation allows flexibility in the division of bandwidth between upstream and downstream
- Same MAC can be easily adapted to FDD mode of operation.
- Support of variable-length packets and collision avoidance enhance MAC efficiency
- MAC can support IP, ATM and other kinds of traffic
- MAC can provide wire equivalent security

### Reference Model

The MAC sub-layer services the LLC sub-layer, using the PHY layer. Each upper layer protocol has a transmission convergence sub-layer that maps its specific parameters (like QoS) into 802.16 native parameters. The transmission convergence sub-layers transform the different upper layer protocols objects into a uniform 802.16 format. The various convergence sub-layers may fragment or concatenate frames of the upper layer protocol, and are responsible for proper LLC operation as required by the specific upper layer protocol (e.g. reliable or unreliable transport, connection oriented or connectionless, etc.).

Services that only broadcast from the BST modem (e.g. Digital Audio/Video) are allowed to access the PHY directly.

The reference model is depicted bellow,

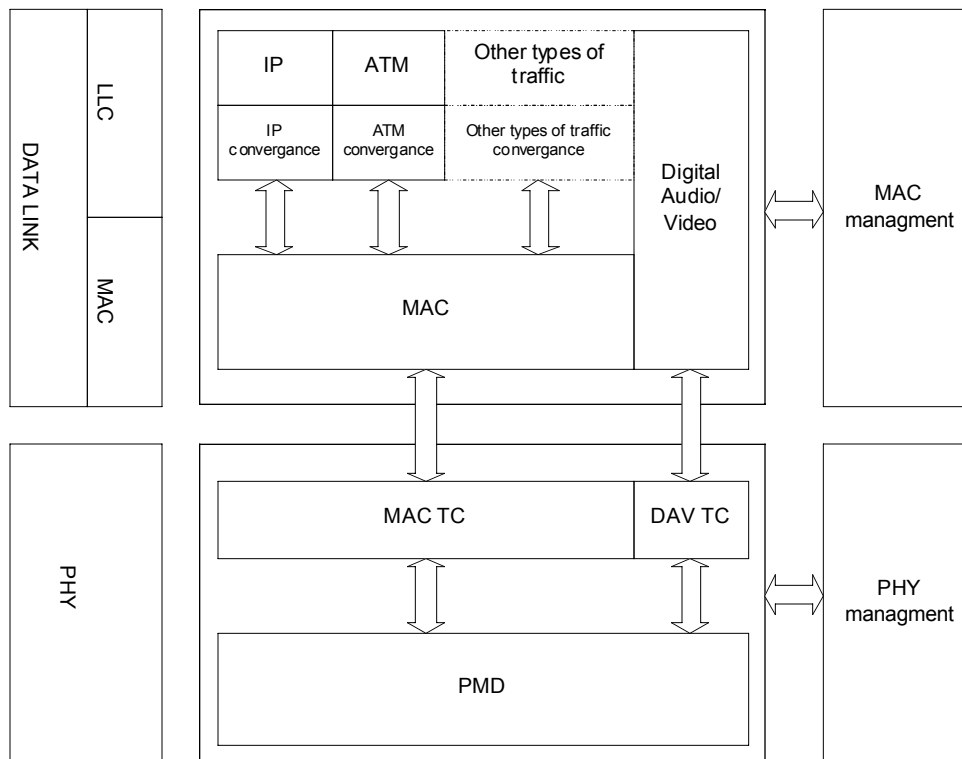

Figure 1. MAC reference model

## **MAC service definition**

### ***1.1. Asynchronous data service***

This service provides LLC entities with the ability of burst exchange of MAC service data units (MSDUs). To support this service, the local MAC uses the underlying PHY-level services to transport an MSDU to a peer MAC entity, where it will be delivered to the peer LLC. The available classes of service for this service are TBD. All stations will support the asynchronous data service.

### ***1.2. Synchronous data service***

This service provides LLC entities with the ability to exchange a constant, pre-defined stream of MSDUs. The parameters of this stream (length, rate, delay etc.) will be negotiated prior to establishing the stream. The available classes of service for this service are TBD. All stations will support the synchronous data service.

### ***1.3. MSDU ordering***

The services provided by the MAC sub-layer permit, and may in certain cases require, the reordering of MSDUs. There will exist a class of service that will avoid MSDU reordering.

### ***1.4. Security services***

The security services provided by the MAC are

- a) Privacy
- b) Authentication
- c) Access control

The mechanism for their provision is TBD.

## Frame Format

Each MAC packet consists of the three components,

- a) A *MAC header*, which contains frame control information.
- b) A variable length *frame body*, which contains information specific to the frame *type*.
- c) A *frame check sequence* (FCS), which contains an IEEE 32-bit cyclic redundancy code (CRC).

All stations shall be able to properly construct frames for transmission and decode frames upon reception.

### 1.5. General frame format

The MAC frame format contains a set of fields that occur in a fixed order in all frames. The frames are generally divided into data frames, control frames and management frames. The general MAC frame structure is shown bellow,

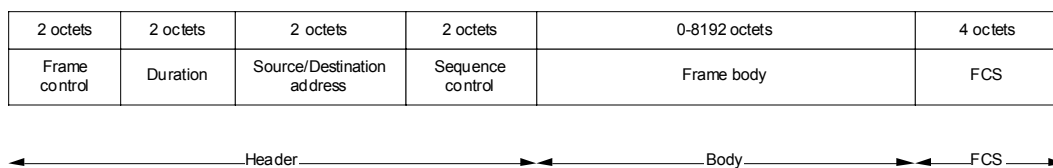

*Figure 2. MAC general frame format*

The various fields within the frame are,

- 1st. Frame control – Defines parameters like the frame type and subtype, whether it is a retry or not, and other basic parameters. Exact contents and mapping is TBD.
- 2nd. Duration – This field defines a transaction duration, and is relevant in contention based access to the media. In this case if some modems hear even part of a transaction it can avoid accessing the media and disturbing that transaction.
- 3rd. Source/Destination address – Defines the sender or target of a certain packet. The other party for a transaction will always be the BST modem.
- 4th. Sequence control – Allows the protocol to track the order of received frames, and reorder them before handing to an upper layer.
- 5th. Frame body – Contains the information to be transmitted.
- 6th. FCS – A standard cyclic redundancy check that allows detection of erred frames.

In addition to the general frame format shown above, protocol management frames may utilize the header fields for different purposes than those described above. The exact structure of the various management frames is TBD.

## MAC sub-layer functional description

### 1.6. Time slots

The time in which an opportunity to transmit data exists is divided to constant length time slots. All media access in both upstream and down stream direction must start on a time slot boundary. The reference for the time slots boundaries will be the BST modem.

The time required for transmission over the air, PHY processing delay, transitions of the RADIO between transmit and receive and other such delays are taken into consideration through the time period called inter-frame space (IFS).

### 1.7. Downstream traffic

In the downstream direction there is no channel contention. The BTS modem can therefore access the media without restriction. A typical exchange in the downstream direction is shown bellow, with timing reference at the BTS. For simplicity the transmission time over the air has been assumed zero in this drawing.

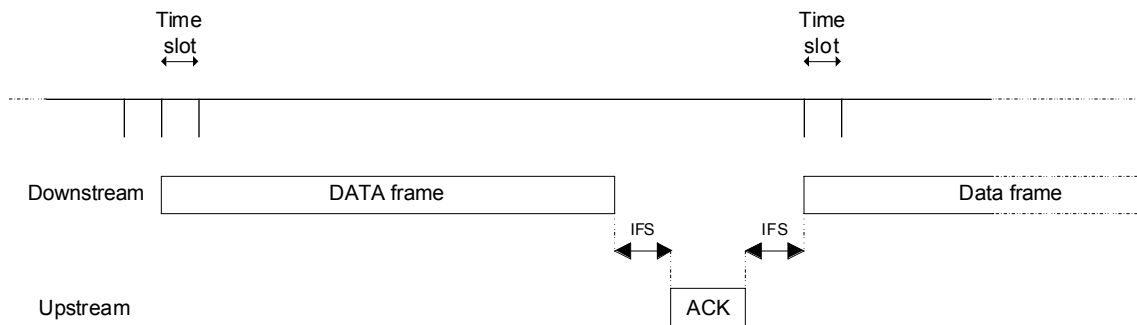

Figure 3. MAC downstream flow

### 1.8. Upstream traffic

In the upstream direction the channel contention has to be resolved. Any channel by the CPE modem is controlled by the BTS modem. Two access mechanisms exist, one is reservation based and the other contention based.

#### 1.8.1. Reservation based access

When using the reservation mechanism the CPE modem has been pre-assigned by the BTS modem a time slot for its transmission and duration for the transmission. All CPE modems know the position and duration of the reservation frame, and can keep track of the BTS time slots. A typical reservation based exchange in the upstream direction is shown bellow, with timing reference at the BTS. For simplicity the transmission time over the air has been assumed zero in this drawing.

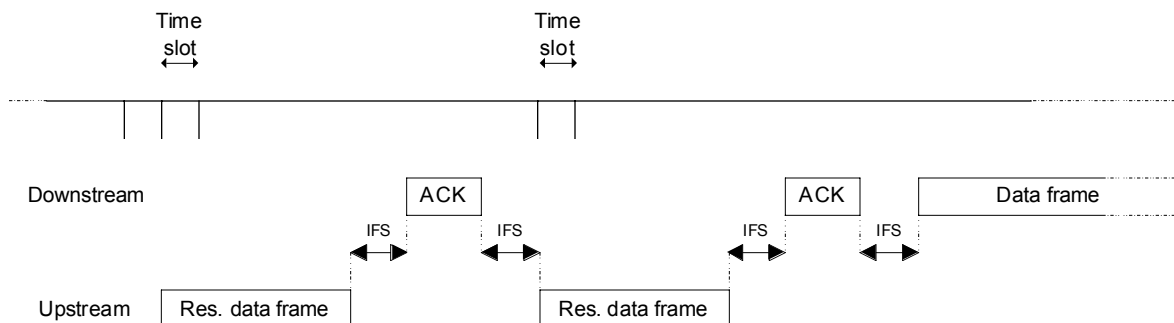



Figure 4. MAC upstream – reservation based - flow

**1.8.2. Contention based access**

Usage of the contention mechanism is controlled by the BTS modem. The CPE modems are divided by the BTS into groups. Each group is polled at its turn, and after being polled its members are allowed to access the media using a collision avoidance mechanism. The collision avoidance mechanism is based on a short RTS-CTS exchange before the actual packet transmission. In addition a backoff counter is maintained by each CPE modem to lower the probability of collision in case the media gets momentarily congested. If the RTS-CTS exchange is successful the actual packet transmission takes place. A successful contention based exchange in the upstream direction is shown bellow, with timing reference at the BTS. For simplicity the transmission time over the air has been assumed zero in this drawing.

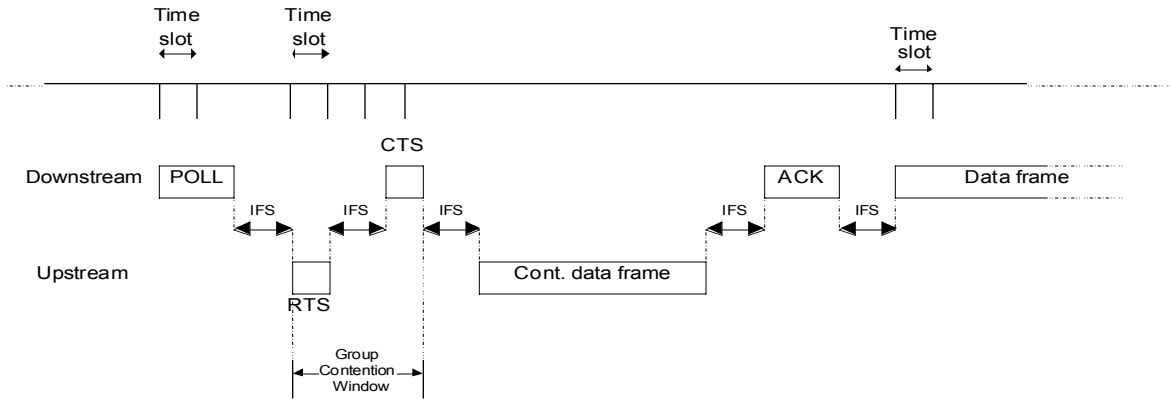

Figure 5. MAC upstream – contention based flow

If two RTS packets from different CPE modems collide, the BTS modem will not return a CTS packet. In this case either a third CPE modem transmitting its RTS packet in the next time slot wins the media, or if no other CPE modem wants to transmit, the BST modem sends downstream packets, or polls another group of CPE modems. After a collision the modems involved in the collision initiate their backoff procedure. The backoff procedure consists of deferring transmission for a random number of time slots. The random number should be between one to the maximum backoff window. The maximum backoff window is increased (up to a certain maximum) after each collision, and decreased after each successful transmission. A contention based exchange in the upstream direction in which a collision occurred is shown bellow, with timing reference at the BTS. For simplicity the transmission time over the air has been assumed zero in this drawing.

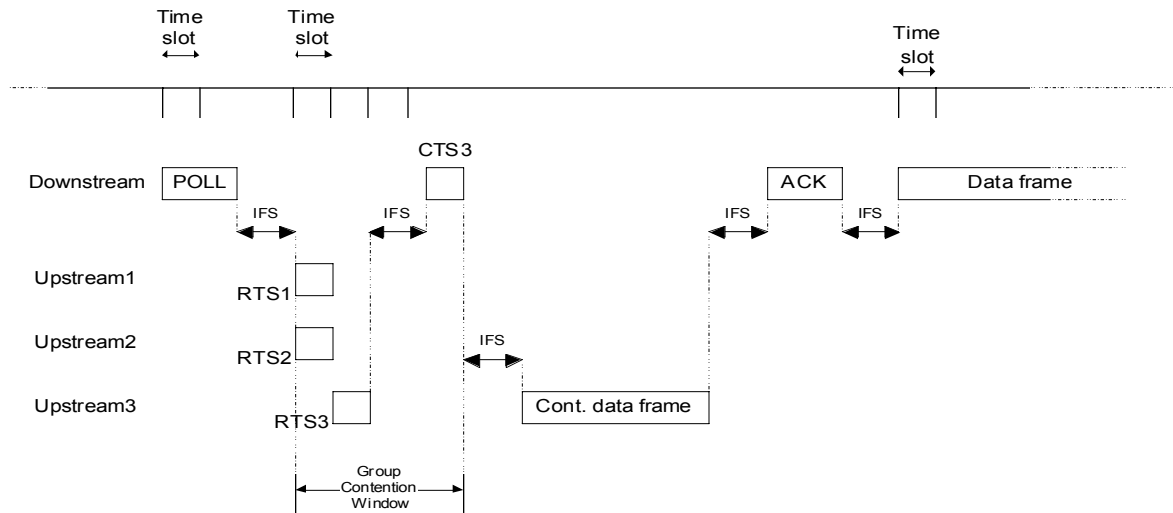

Figure 6. MAC upstream – contention based flow with a collision

### 1.9. Synchronization

The BST modem is the source of all timing information for the CPE modems. The BST modem must periodically send synchronization frames. These frames contain timing information for the reservation based access mode, and enable the CPE modems to determine to point where they may capture the media. In addition time stamp information is provided, that allow the CPE modems to synchronize their time slots to the BST modem. The structure of the synchronization frames and the synchronization algorithm are TBD.

### 1.10. Bandwidth allocation

The quality of service and the bandwidth allocated to each customer is set by the BST modem. Each CPE modem can get top quality of service through use of reservation based access (suitable mainly for predictable multimedia streams). Quality of service is controllable for contention based access as well through controlling the size and members of the polled groups.

### 1.11. Protocol control

The protocol will have control frames for sizing and managing the contention groups, and for managing the reservations, etc. The exact structure and functions of these frames are TBD.

### 1.12. MAC layer management

TBD

**1.13. Extension for the FDD case**

The protocol can be adapted to full duplex operation by introducing the following modifications,

1. Divide the time axis into alternating, equal duration periods called TX and RX. In the TX periods the BST modem will only transmit data and the CPE modems will only receive data, and vice versa in the RX period.
2. For downstream packets the data packet is transmitted by the BST modem as before, but the ACK packet is transmitted in the RX period. The ACK packet transmission timing can be explicitly or implicitly stated by the downstream data packet.
3. For upstream reservation based access the data packet is transmitted by the CPE modem as before, but the ACK packet is transmitted in the TX period. The ACK packet timing is irrelevant in this case.
4. For upstream contention based access, the POLL packet (which may contain many polls now) is transmitted in the TX period and sets the contention windows for the various groups. The RTS packets are transmitted in the next RX period, but are not answered by CTS packets. Instead the RTS packet are treated as reservation requests. Those RTS packets that were received correctly (i.e. without a collision) by the BST modem are awarded a transmission in the same manner used for reservation based access. CPE modems that have contended for the media and have failed have to go through the backoff procedure as if they did not receive a CTS packet in the TDD scenario.

Up to this point the BST system still uses TDD duplexing method, being half the time in TX mode and half the time in RX mode. In the FDD duplexing case the CPE modems should be divided into two disjoint groups, with interleaved TX and RX periods. Each group will communicate with the BST in the above described TDD method, thus fully utilizing the FDD spectrum. The drawing below shows the timing relations in this system. Note that the CPE modems only need to be half-duplex in this case.

BST downstream	BST TX to group I	BST TX to group II	BST TX to group I	BST TX to group II	
BST upstream	BST RX from group II	BST RX from group I	BST RX from group II	BST RX from group I	
CPE downstream	CPE Modems group II TX to BST	CPE Modems group I TX to BST	CPE Modems group II TX to BST	CPE Modems group I TX to BST	
CPE upstream	CPE Modems group I RX from BST	CPE Modems group II RX from BST	CPE Modems group I RX from BST	CPE Modems group II RX from BST	

*Figure 7. TDD to FDD extension*

## Existing Standards

The contention based access mechanism is taken from the IEEE 802.11 wireless LAN standard. The 802.11 standard supports multiple access by using carrier sensing and RTS-CTS collision avoidance mechanism. It is assumed that in the BWA environment a CPE modem can not sense the carrier of another CPE modem (because of antenna directionality, obstructions, etc.), therefore the carrier sense mechanism is dropped. Another change over the 802.11 is grouping of CPE modems into groups that form contention regions. Each contention region is polled separately to allow higher efficiency (less collisions) and better control of bandwidth and QoS that each CPE modem receives.

## Benefits

1. Mixture of contention and reservation based access.
2. Packet based, random access MAC allows high efficiency with upstream bursty data traffic.
3. An acknowledgement based ARQ mechanism supports reliable data transmission.
4. TDD mode of operation allows lower cost systems, more efficient usage of the spectrum.
5. Inherent scalability through division into contention groups.
6. Dynamic bandwidth allocation, and low delay reservation based access allow support of voice and multimedia traffic.
7. Easy conversion from TDD duplexing mode to FDD duplexing mode.