

Project	IEEE 802.16 Broadband Wireless Access Working Group	
Title	Refined proposal for the 802.16 PHY	
Date Submitted	1999-12-23	
Source	<p>Lars Lindh Nokia Research Center P.O. Box 407, FIN-00045 NOKIA GROUP, Finland</p> <p>Carl Eklund Nokia Research Center P.O. Box 407, FIN-00045 NOKIA GROUP, Finland</p> <p>Petri Bergholm Nokia Networks P.O. Box 370, FIN-00045 NOKIA GROUP, Finland</p>	<p>Voice: +358 9 4376 6671 Fax: +358 9 4376 6851 E-mail: lars.lindh@nokia.com</p> <p>Voice: +358 9 4376 6566 Fax: +358 9 4376 6851 E-mail: carl.eklund@nokia.com</p> <p>Voice: +358 9 511 27230 Fax: +358 9 511 27329 E-mail: petri.bergholm@nokia.com</p>
Re:	This contribution is submitted in response to the invitation to contribute for Session #5.	
Abstract	This proposal contains solutions for the 802.16 PHY layer to make low cost terminals possible and thus to address the small-business as well as the residential market.	
Purpose	Proposal to serve as a baseline for the 802.16 PHY standard.	
Notice	This document has been prepared to assist the IEEE 802.16. It is offered as a basis for discussion and is not binding on the contributing individual(s) or organization(s). The material in this document is subject to change in form and content after further study. The contributor(s) reserve(s) the right to add, amend or withdraw material contained herein.	
Release	The contributor acknowledges and accepts that this contribution may be made public by 802.16.	
IEEE Patent Policy	<p>The contributor is familiar with the IEEE Patent Policy, which is set forth in the IEEE-SA Standards Board Bylaws <http://standards.ieee.org/guides/bylaws> and includes the statement:</p> <p>“IEEE standards may include the known use of patent(s), including patent applications, if there is technical justification in the opinion of the standards-developing committee and provided the IEEE receives assurance from the patent holder that it will license applicants under reasonable terms and conditions for the purpose of implementing the standard.”</p>	

Proposal of Nokia for the 802.16 PHY

This physical layer specification contains solutions for transmitting bi-directional data over millimeter wave radio channels. It is proposed for the IEEE 802.16.1 Broadband Wireless Access addressing the needs for broadband communication in a point-to-multipoint environment.

Studies are being made, between Nokia and the contributors of similar proposals, to merge the contributions into one common joint proposal for the IEEE 802.16.1 standard to be presented in an upcoming meeting.

Broadband wireless access (BWA) technology has to compete with a variety of other technologies, some of which already are available and others that will come in the near future. Examples of competing technologies are T1 lines, ISDN, xDSL pairs and HFC networks.

For 802.16 to be successful it must be able to offer a rich set of services on low cost terminals to residential and small business customers. In order for BWA to get a large market share it is important to have an interoperability standard.

Duplex Scheme

The Broadband Wireless system can use FDD or TDD. When in FDD mode, the basestation uses full duplex FDD and the terminals half duplex FDD.

Time Division Duplex (TDD) uses the same frequency band for transmission in both the upstream and the downstream direction. Within a time frame the direction of transmission is switched alternatively between the down link and the uplink.

Frequency Division Duplex (FDD) uses two separate frequency bands for the upstream and the downstream transmissions. FDD can work in both full duplex and half duplex modes. Full duplex FDD needs a duplex filter to separate the received waveform from the transmitted waveform. Half duplex FDD, which does not send and receive at same time, needs only a switch for TX/RX separation.

Channelization

The upstream and downstream uses the same channel width. Different channel sizes are proposed for Europe and US. Europe uses 28 MHz channel size and US 25 MHz.

Frame Structure

The frame structure for FDD and H-FDD uses two separate channels. The channel size is the same for both upstream and downstream but the modulation is different. Anticipating an asymmetric use and a need for low cost terminals the downstream carries QAM modulated signals and the upstream TFM modulated signals. The basestation operates always in full duplex FDD. The basic frame structure for FDD is shown in figure 1. One frame period is 1 ms.

FRAME

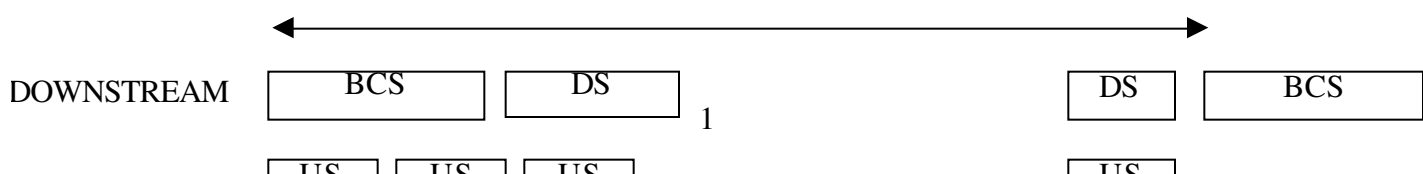

Figure 1. Basic frame structure for FDD

In the TDD case the upstream and downstream are sharing the same channel and the frame structure is shown figure 2.

Frame synchronization

The transmission frame has a length of one millisecond. A preamble marks the beginning of the frame. Initial synchronization of the terminal should be made by detecting the Preamble ten consecutive times at 1 ms interval. The Preambles at 1 ms regular intervals form the master synchronization for the terminals. The terminal can also obtain the phase and symbol synchronization from the Preamble. The downstream signal from a FDD basestation is a continuous waveform. A TDD system, however, time multiplexes the downstream and the upstream in the frame.

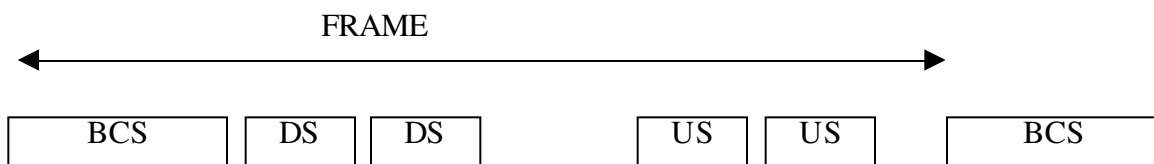
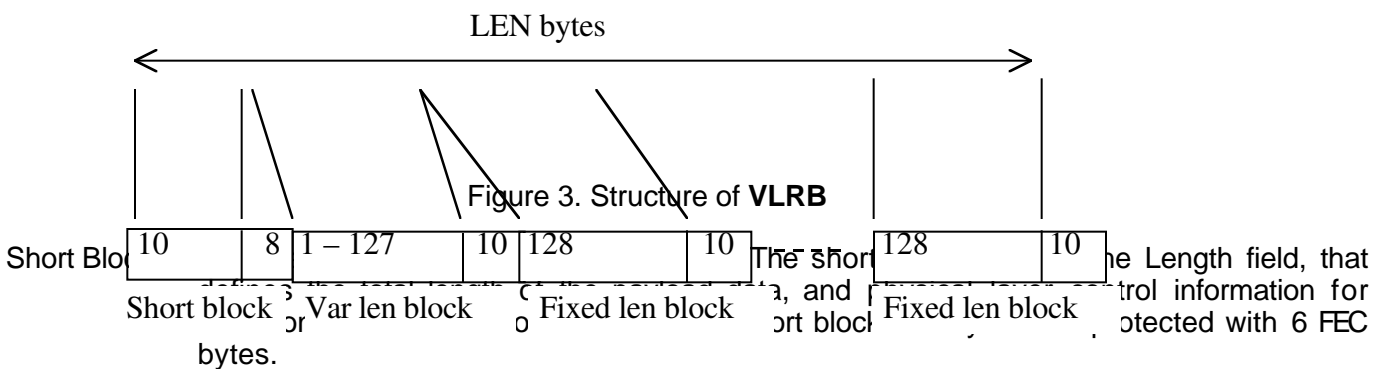

Figure 2. TDD frame structure.

Frame segments

The frame is divided into different segments. On the PHY layer the segments are the Broadcast Segment (**BCS**), Downlink Segment (**DS**) and Uplink Segment (**US**). Each segment consists of a synchronization part followed by Variable Length Reed-Solomon Block (**VLRB**). The basic segment form is showed in figure 3. The Variable Length Reed-Solomon Block consists of a Short Block, a Variable Length Block and zero or several Fixed length Blocks. The length of the Fixed Length Block excluding the RS-parity is 128 bytes and RS-Parity bytes are 10 bytes.



Var len Block The basic block size of the variable Reed-Solomon Block is 128 bytes. When the payload length is not a multiple of 128 the first block will be shortened. The length of the payload part of the SB will be

$$(LEN - 8) \text{ mod}(128)$$

The Variable length block is then protected with 10 FEC bytes.

Fixed Block The length of the payload of the Long Block is always 128. If the data is shorter than 128 bytes there will be no Long Block. The RS-parity bytes are appended to the Long Block.

The Variable length block and the Fixed length blocks can optionally be interleaved in order spread burst errors from TCM decoder.

The Reed-Solomon code is computed over G(256) with the following field generator polynomials:

Code Generator Polynomial: $g(x)=(x+\mu^0) (x+\mu^1) (x+\mu^2) \dots (x+\mu^n)$

Field Generator Polynomial: $x^8 + x^4 + x^3 + x^2 + 1$

Broadcast Segment

Each frame starts with a broadcast segment. The BCS is transmitted in the downstream direction and contains synchronization and control information needed for every terminal. In BCS is also the up- and downstream slot allocations maps for the MAC-layer transmitted. The BCS segment is transmitted at the lowest modulation level so that every terminal is able to receive it.



Figure 4. Broadcast Segment (BCS)

Downlink Segment

In Downlink Segment (DS) is the actual downstream terminal data transmitted. The DS starts with a short preamble to help terminals that has been transmitting to regain synchronization. The preamble is shorter than the one in the BCS because only phase synchronization must be regained. The data for the terminal is packed into variable length Reed-Solomon block. The DS segment can be TCM-8 or TCM-32 or optionally TCM-128 modulated.



Figure 5. Downlink Segment (DS)

Uplink Segment

The Uplink Segment (US) contains data transmitted from the terminal to the basestation. It also consists of a preamble and a Variable Length Reed-Solomon Block (VLRB). Because there is no symbol level synchronization between the terminals and the basestation in the upstream, the US starts with a preamble and is followed with a variable Reed-Solomon Block. The US segment uses TFM modulation. Uplink Segments are separated with a gap consisting of four symbols.



Figure 6. Uplink Segment (US)

DOWNSTREAM

The downstream uses a continuous TCM modulation format, which provides 3 different modulation schemes (TCM-8, TCM-32 and optional TCM-128). The modulation can be adaptively changed on a burst to burst basis. The downstream processing includes randomization, RS-coding, preamble prepend, TCM-coding, pulse shaping and modulation. The downstream data flow is shown in figure 7.

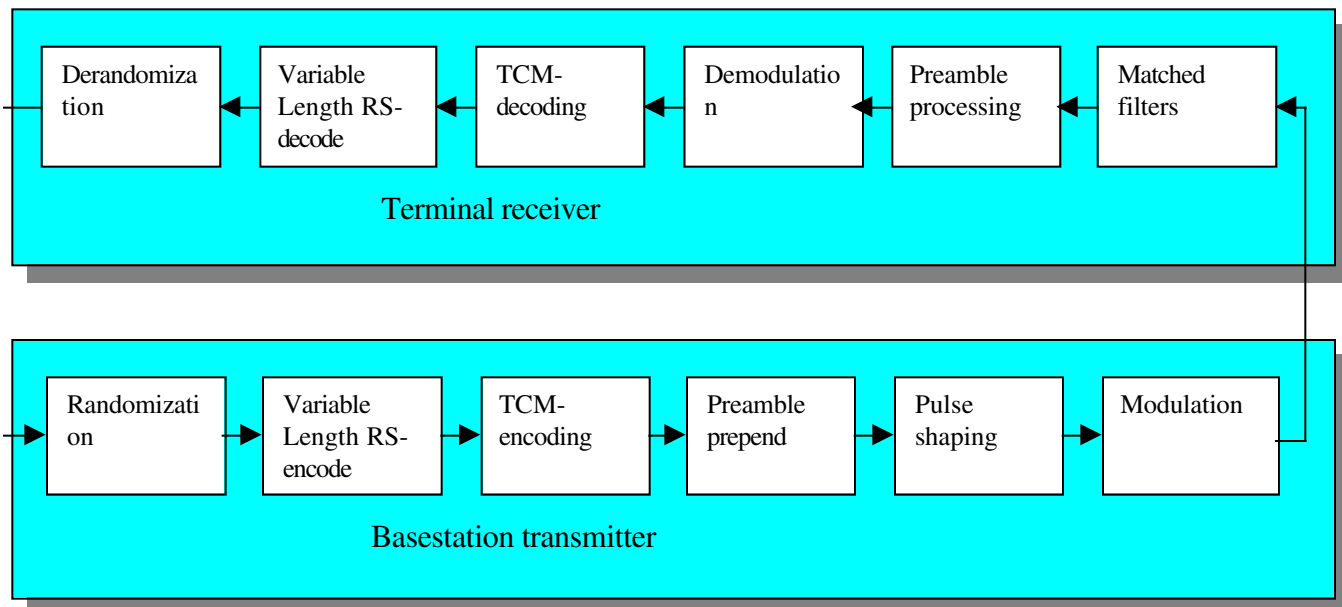

Figure 7. Downstream data flow.

Randomization

Data must be randomized for spectrum shaping in accordance with figure 8. The polynomial for the Pseudo Random Binary Sequence (PRBS) is

$$1 + X^{14} + X^{15}$$

The data is randomized on a segment basis and the preamble in each segment initializes the shift register with the sequence "1001010100000000". The first bit of the PRBS generator shall be applied to the MSB of the first byte following the preamble. The randomizer is shown in figure 8. The scheme works for both randomizing and derandomizing the data.

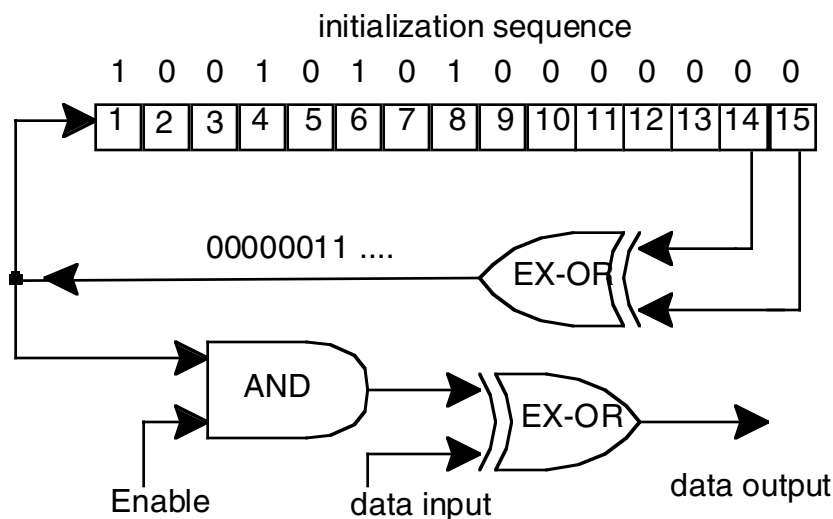

Figure 8. Randomizer diagram

Reed-Solomon Coding

Following the spectrum shaping the segments are packed into Variable Length Reed-Solomon Blocks (VLRB) according to the scheme in figure 3, with T=5. This means that 5 erroneous bytes per 128 bytes blocks can be corrected. This process adds 10 parity bytes to the 128 bytes block to give a codeword (138,128). The Reed-Solomon code shall have the following generator polynomials:

Code Generator Polynomial: $g(x) = (x+\mu^0)(x+\mu^1)(x+\mu^2) \dots (x+\mu^{15})$, where $\mu=02\text{hex}$
Field Generator Polynomial: $p(x) = x^8 + x^4 + x^3 + x^2 + 1$

The shortened Reed-Solomon code shall be implemented by appending bytes, all set to zero, before the information bytes at the input of a (138, 128) encoder; after the coding procedure these bytes are discarded.

Trellis-Coded-Modulation (TCM)

Trellis-Coded Modulation (TCM) is applied to the RS-encoded data.

TCM-Encoder

An Ungerboeck encoder is shown in figure 9. m information bits x^1, x^2, \dots, x^m are taken from the data stream and are mapped to the 2^{m+1} point constellation. k of the signals are encoded using a rate $k / (k+1)$ convolutional encoder. The k+1 output bits of the encoder are used to select one of the 2^{k+1} partitions of the

constellation. The remaining $m - k$ information bits are used to select a particular signal within the selected partition.

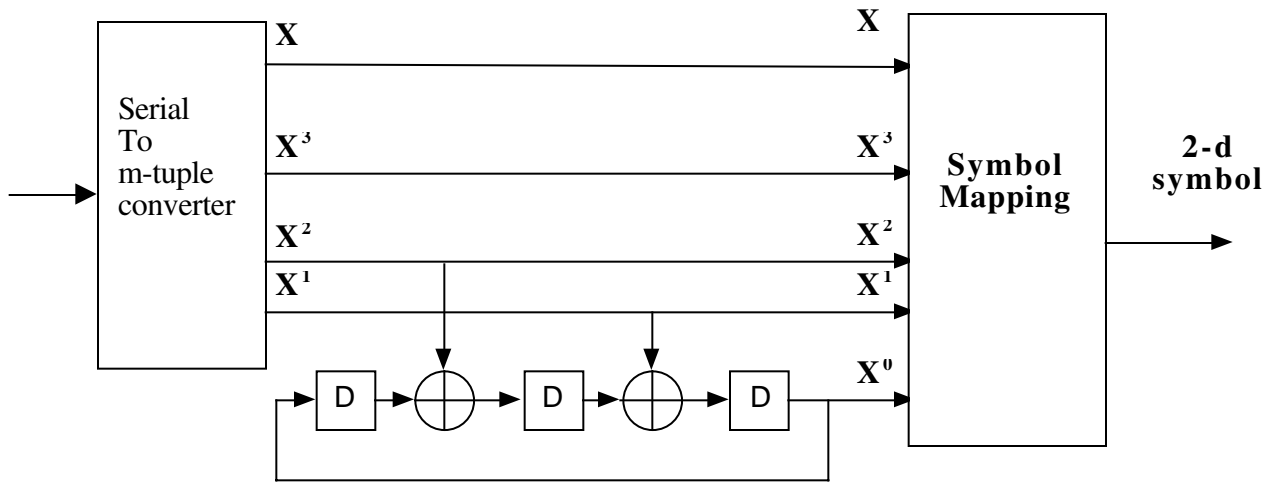

Figure 9. 8-state Ungerboeck encoder

The encoder starts from state zero and after the data is encoded two additional symbols are transmitted to force the encoder back to state zero. The symbol mapper maps the signals to an actual waveform from the constellation.

Byte to m-tuple conversion

The serialized bytes come **MSB** first before conversion into m-tuples as shown in Figure 10.

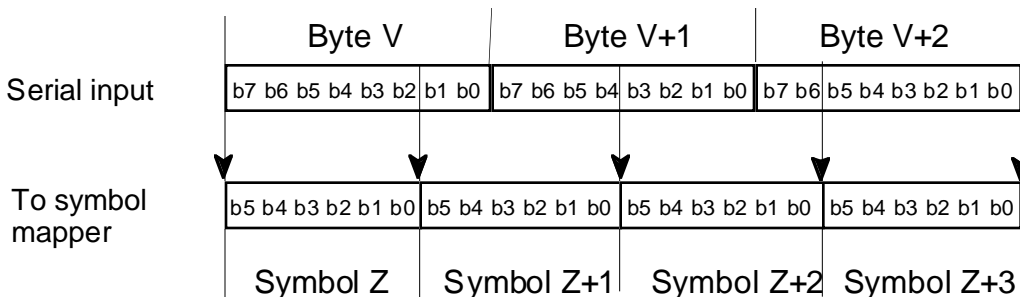

Figure 10. Byte to m-tuple conversion ($m=6$)

The Symbol Mapper

The symbol mapper maps the symbols into a QAM constellation. TCM-8 is mapped in PSK-8 manner as shown in figure 11. TCM-32 and TCM-128 are shown in Figure 12. The constellation point mapping is indicated in octal notation. The preamble is always mapped according to a QPSK constellation.

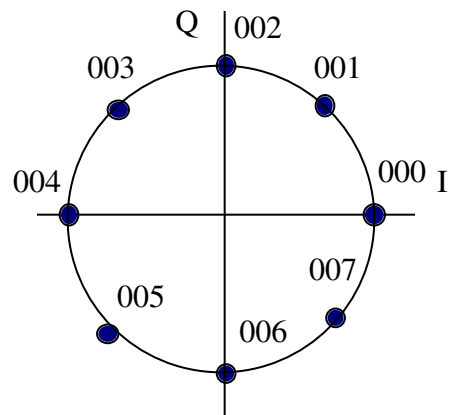

Figure 11. Mapping for TCM-8

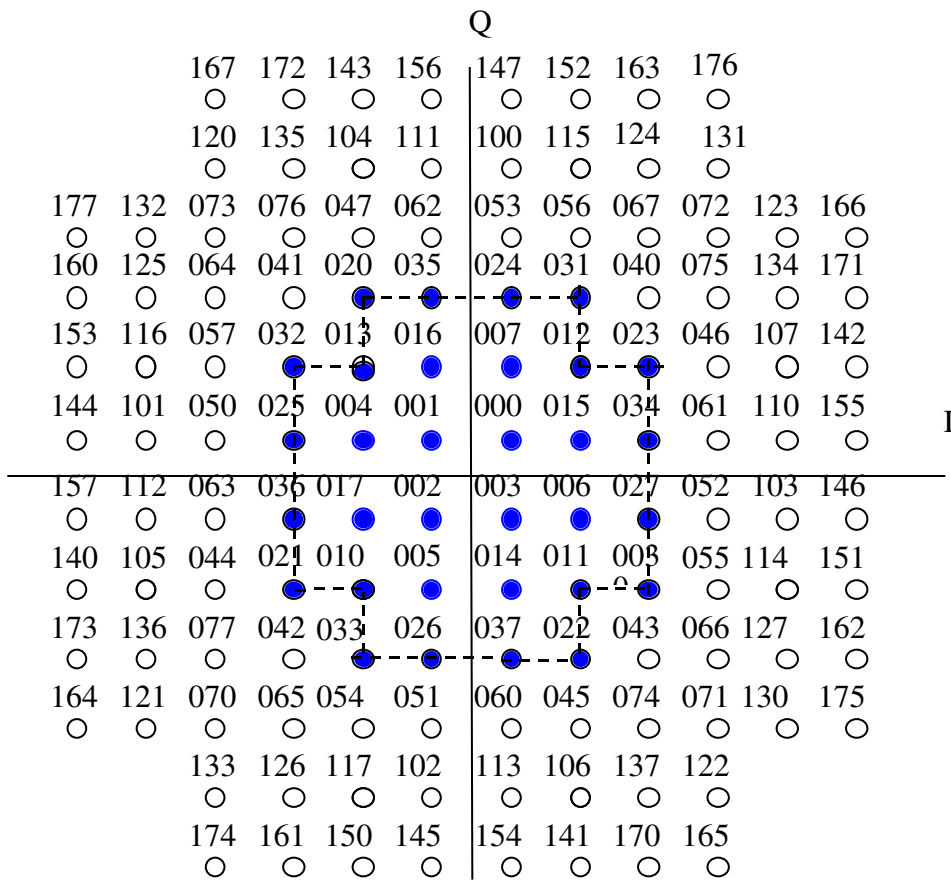

Figure 12. Mapping for TCM-32 and TCM-128

Baseband filters

Prior to modulation, the I and Q signals shall be square-root raised cosine filtered. The roll-off factor shall be 0.25. The square-root raised cosine filter shall have a theoretical function defined by the following expression:

$$H(f) = \begin{cases} 1 & \text{for } |f| < f_N(1 - \alpha) \\ \frac{1}{2} + \frac{1}{2} \sin \frac{\pi}{2f_N} \frac{f_N - |f|}{\alpha} & \text{for } f_N(1 - \alpha) \leq |f| \leq f_N(1 + \alpha) \\ 0 & \text{for } |f| > f_N(1 + \alpha) \end{cases}$$

where $f_N = \frac{1}{2T_s} = \frac{\kappa_s}{2}$ is the Nyquist frequency and roll-off factor $\alpha = 0.25$.

Modulation

The filtered I and Q signals are QAM modulated according to the following relationship

$$s(t) = I(t) \cos(\omega t) - Q(t) \sin(\omega t)$$

where s(t) is the transmitted waveform, I(t) and Q(t) are the filtered I- and Q-channel waveforms corresponding to the specified transmit constellation, t is time w is angular frequency.

Downstream bitrates

With $\alpha = 0.25$ the downstream bitrates are according to table 1.

Channel width	TCM-8	TCM-32	TCM-128
25 MHz	40.0 Mb/s	80 Mb/s	120 Mb/s
28 MHz	44.8 Mb/s	89.6 Mb/s	134.4 Mb/s

Table 1. Downstream bitrates

UPSTREAM

The upstream transmissions always happen in the form of a Upstream Segment (US). The US consists of a preamble followed by Variable Length Reed-Solomon Block. USs from different terminals are separated by gap consisting of four symbols. Because the terminals are not synchronized on the symbol level to the basestation a long preamble is needed in the beginning of the US. The upstream data flow is shown in Figure 13.

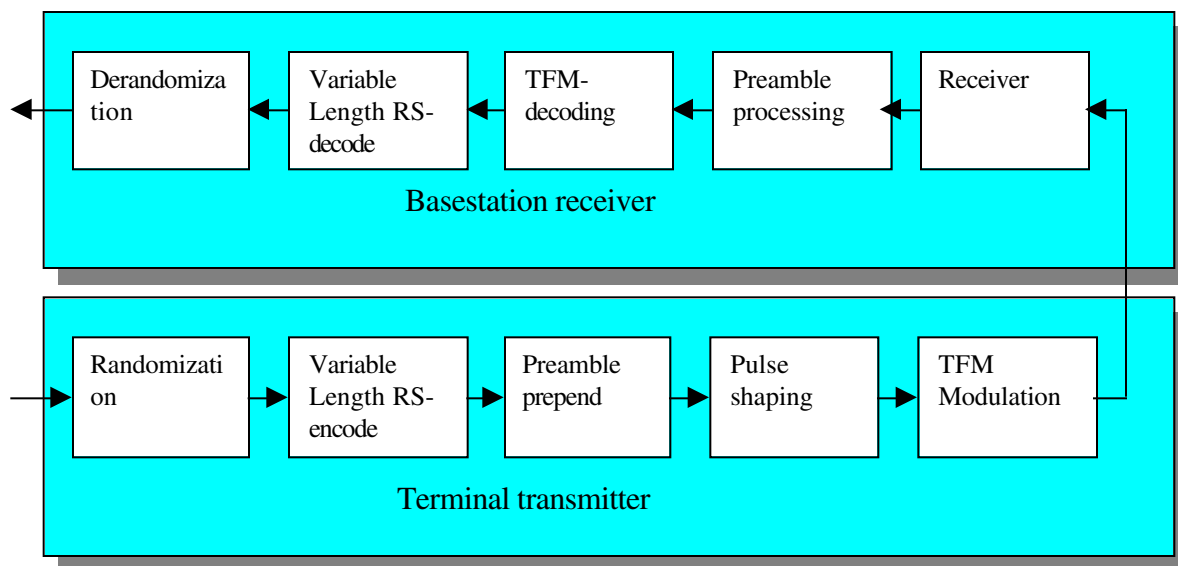

Figure 13. Upstream data flow

Upstream burst

The upstream burst consists of an Upstream Segment (US) followed by a guard time of four symbols. The guard time is needed because it is assumed that the terminal and the basestation are not synchronized at the symbol level. The upstream burst is shown in Figure 14.

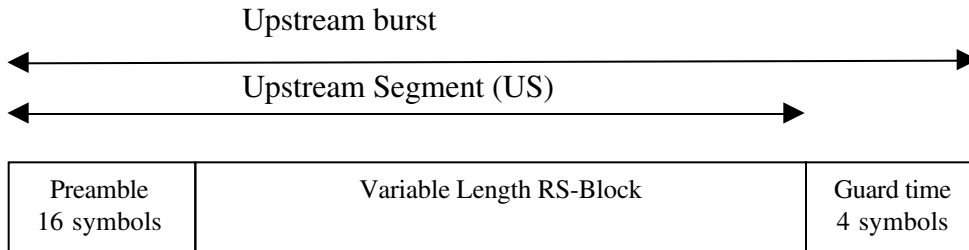

Figure 14. Upstream burst

Randomization

The Variable Size RS-Block is randomized with according to the scheme showed in figure 15. It is assumed that the data is going serially, MSB first, through the randomizer.

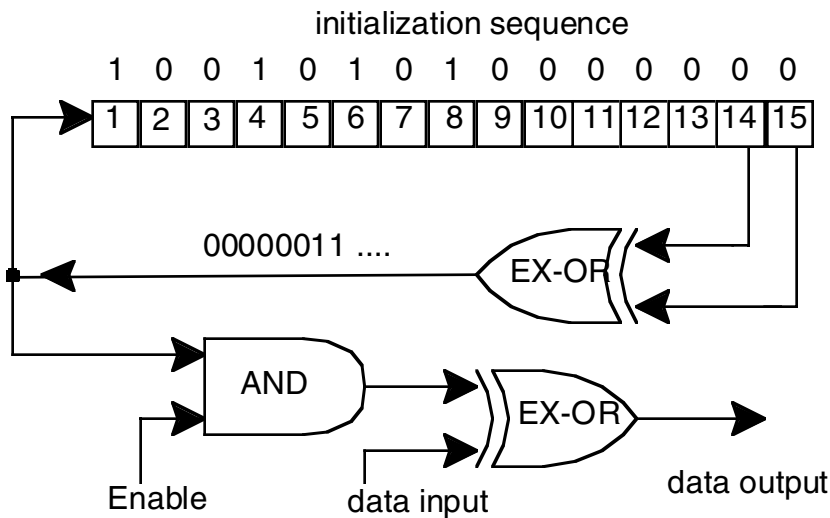

Figure 15. Upstream randomizer/derandomizer

RS-coding

The data is divided into Variable Sized RS-blocks as described in Figure 3. The Reed-Solomon code shall have the following generator polynomials:

Code Generator Polynomial: $g(x) = (x+\mu^0)(x+\mu^1)(x+\mu^2) \dots (x+\mu^{15})$, where $\mu = 02_{\text{hex}}$
Field Generator Polynomial: $p(x) = x^8 + x^4 + x^3 + x^2 + 1$

The shortened Reed-Solomon code shall be implemented by appending bytes, all set to zero, before the information bytes at the input of a (138, 128) encoder; after the coding procedure these bytes are discarded.

Tamed Frequency Modulation (TFM)

The Upstream Segments are TFM modulated. Tamed Frequency Modulation (TFM) is a kind of Continuous Phase Modulation. In all continuous phase modulations, the RF signal envelope is constant and phase varies in a continuous manner. CPM signals can be described by

$$s(t) = \sqrt{\frac{2E_s}{T}} e^{j\phi(t, \hat{\mathbf{a}})}$$

where E_s is the symbol energy. The phase $\phi(t, \hat{\mathbf{a}})$, during symbol interval $kT < t < (k+1)T$, has the form

$$\phi(t, \hat{\mathbf{a}}) = \eta(t, C_k, \alpha_k) + \Phi_k$$

$$\eta(t, C_k, \alpha_k) = 2\pi h \sum_{i=k-L+1}^k \alpha_i q(t - iT)$$

$$h = K/P$$

$$C_k = (\alpha_{k-L+1}, \dots, \alpha_{k-2}, \alpha_{k-1})$$

$$\Phi_k = \pi h \sum_{i=-\infty}^{k-L} \alpha_i \pmod{2\pi}$$

In the above equations $\hat{\mathbf{a}} = \{\alpha_i\}$ are the equally likely and independent M -ary data symbols $\{\pm 1, \pm 3, \dots, \pm(M-1)\}$, C_k is the correlative state and Φ_k is the phase state of the modulator. The modulation index is denoted by h , and it is a ratio of two relatively prime integers. The phase pulse of the modulator is normalised in such a way that

$$q(t) = \begin{cases} 0 & t \leq 0 \\ 1/2 & t \in [LT, \dots] \end{cases}$$

Its derivative $dq(t)/dt = g(t)$ is the frequency pulse of the modulator. The frequency pulse has the length of L symbol interval. If $L=1$, the corresponding CPM scheme is called full response CPM. In other cases ($L > 1$), the scheme is called partial response CPM. By choosing different frequency pulses $g(t)$ and varying the parameters h and M , a great variety of CPM schemes can be obtained. As the benchmark of MORE project is the TFM, we shall define to this particular CPM-type modulation method more in details.

By introducing the correlation, TFM signal provide narrower power spectrum than MSK signal. The constellation points of TFM is shown is figure 16.

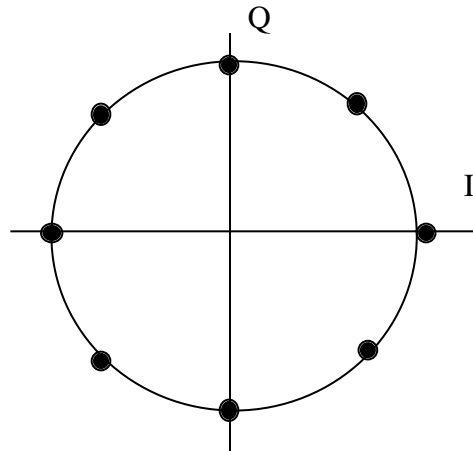

Figure 16. TFM constellation points

Baseband filtering

The filtering of the data is defined by the following expression:

$$g(t) = \frac{1}{8}g_0(t-T) + \frac{1}{4}g_0(t) + \frac{1}{8}g_0(t+T)$$

$$g_0(t) \cup \sin \frac{-\pi t}{T} \sqrt{\frac{1}{\pi}} - \frac{2 - \frac{2\pi}{T} \cot \frac{-\pi t}{T} \sqrt{-\frac{\pi^2 t^2}{T^2}}}{24\pi t^3} \frac{\pi^2 t^2}{T^2}$$

Upstream Bitrates

The upstream bitrates, assuming a spectral efficiency of 1.3, is according to Table 2.

Channel width	TFM
25 MHz	32.5 Mb/s
28 MHz	36.4 Mb/s

Table 2. Upstream bitrates

Benefits of the proposed PHY

The driving force behind the proposal is simplicity and low cost. Half duplex FDD and TDD are seen as way of dramatically decrease the cost of the terminals. TDMA is proposed for its ability to fulfill the requirements of statistical multiplexing. Variable modulation in the downlink gives a higher coverage with low C/N and a higher capacity with high C/N. Tamed frequency modulation (TFM) makes possible low cost solutions for the terminals.

Relations to existing standards

This proposal does not relate to any existing standards because it is believed that it is difficult to directly utilize existing cable standards because of different interference conditions signal propagation properties. In Europe ETSI BRAN HIPERACCESS develops a similar standard for wireless broadband access networks. Efforts should be made to harmonize 802.16 and HIPERACCESS. This will lead to higher volumes and decreased manufacturing costs.

Statement of intellectual property rights

Nokia may have IPR in the standards under consideration. If Nokia has any applicable essential patents, it will comply with the IEEE IPR rules regarding disclosure and licensing.

Evaluation Table

#	Criterion	Discussion
1	Meets system requirements	This proposal is believed to address the items in the system requirements.
2	Spectrum efficiency	The combination of adaptive modulation in combination with half-duplex FDD makes a high system capacity possible.
3	Simplicity of implementation	The technical solutions are based on known technology
4	CPE cost optimization	CPE cost aspects has been emphasized in this contribution. The choice of modulation scheme for the upstream is the most important single factor reducing the cost of the CPE.
5	Spectrum resource flexibility	The proposed system can be used for different channel widths
6	System diversity flexibility	The proposed system can support various network architectures
7	Protocol interfacing complexity	Small delays and variable length packets make protocol interfacing easy
8	Implications on other network interfaces	Can handle various upper layer structures

9	Reference system gain	TFM modulation uses negative back-off and has consequently a high system gain
10	Robustness to interference	Adaptive modulation can optimize the use in different levels of interference
11	Robustness to channel impairments	Equalization can easily be implemented in the receivers although they are not included in the standard proposal