

Project	IEEE 802.16 Broadband Wireless Access Working Group < http://ieee802.org/16 >	
Title	Proposed P802.16/Conf03 Draft, based on IEEE C802.16.3-03/01r1	
Date Submitted	2003-07-14	
Source(s)	Lars Lindh Nokia Research Center P.O. Box 407 FIN-00045 Nokia Group	Voice: +358 50 483 6671 Fax: +358 7180 36851 mailto:lars.e.lindh@nokia.com
	Ken Stanwood Ensemble Communications 9890 Towne Centre Dr San Diego, CA 92121	Voice: +1 (858) 404-6559 Fax: +1 (858) 458-9860 mailto:ken@ensemble.com
Re:	Call for Contributions (802.16Conf03-03/02)	
Abstract	IEEE C802.16.3-03/01r1, reformatted as a draft with correction of some errors and omissions.	
Purpose	To become the first official P802.16/Conf03 draft.	
Notice	This document has been prepared to assist IEEE 802.16. It is offered as a basis for discussion and is not binding on the contributing individual(s) or organization(s). The material in this document is subject to change in form and content after further study. The contributor(s) reserve(s) the right to add, amend or withdraw material contained herein.	
Release	The contributor grants a free, irrevocable license to the IEEE to incorporate material contained in this contribution, and any modifications thereof, in the creation of an IEEE Standards publication; to copyright in the IEEE's name any IEEE Standards publication even though it may include portions of this contribution; and at the IEEE's sole discretion to permit others to reproduce in whole or in part the resulting IEEE Standards publication. The contributor also acknowledges and accepts that this contribution may be made public by IEEE 802.16.	
Patent Policy and Procedures	The contributor is familiar with the IEEE 802.16 Patent Policy and Procedures < http://ieee802.org/16/ipr/patents/policy.html >, including the statement "IEEE standards may include the known use of patent(s), including patent applications, provided the IEEE receives assurance from the patent holder or applicant with respect to patents essential for compliance with both mandatory and optional portions of the standard." Early disclosure to the Working Group of patent information that might be relevant to the standard is essential to reduce the possibility for delays in the development process and increase the likelihood that the draft publication will be approved for publication. Please notify the Chair < mailto:chair@wirelessman.org > as early as possible, in written or electronic form, if patented technology (or technology under patent application) might be incorporated into a draft standard being developed within the IEEE 802.16 Working Group. The Chair will disclose this notification via the IEEE 802.16 web site < http://ieee802.org/16/ipr/patents/notices >.	

Copyright © 2003 by the Institute of Electrical and Electronics Engineers, Inc.

1
2
3
4
5
6
7
8
9
10
11
12
13
14
15
16
17
18
19
20
21
22
23
24
25
26
27
28
29
30
31
32
33
34
35
36
37
38
39
40
41
42
43
44
45
46
47
48
49
50
51
52
53
54
55
56
57
58
59
60
61
62
63
64
65

Grateful acknowledgment is made to the Worldwide Interoperability for Microwave Access (WiMAX) forum for the permission to use the following source material:

Test Suite Structure and Test Purposes for IEEE Standard 802.16, © Copyright 2003, WiMAX Forum.

1 **IEEE Standards** documents are developed within the IEEE Societies and the Standards Coordinating Committees of the
2 IEEE Standards Association (IEEE-SA) Standards Board. The IEEE develops its standards through a consensus develop-
3 ment process, approved by the American National Standards Institute, which brings together volunteers representing varied
4 viewpoints and interests to achieve the final product. Volunteers are not necessarily members of the Institute and serve with-
5 out compensation. While the IEEE administers the process and establishes rules to promote fairness in the consensus devel-
6 opment process, the IEEE does not independently evaluate, test, or verify the accuracy of any of the information contained
7 in its standards.
8

9 Use of an IEEE Standard is wholly voluntary. The IEEE disclaims liability for any personal injury, property or other dam-
10 age, of any nature whatsoever, whether special, indirect, consequential, or compensatory, directly or indirectly resulting
11 from the publication, use of, or reliance upon this, or any other IEEE Standard document.
12

13 The IEEE does not warrant or represent the accuracy or content of the material contained herein, and expressly disclaims
14 any express or implied warranty, including any implied warranty of merchantability or fitness for a specific purpose, or that
15 the use of the material contained herein is free from patent infringement. IEEE Standards documents are supplied “**AS IS.**”
16

17 The existence of an IEEE Standard does not imply that there are no other ways to produce, test, measure, purchase, market,
18 or provide other goods and services related to the scope of the IEEE Standard. Furthermore, the viewpoint expressed at the
19 time a standard is approved and issued is subject to change brought about through developments in the state of the art and
20 comments received from users of the standard. Every IEEE Standard is subjected to review at least every five years for revi-
21 sion or reaffirmation. When a document is more than five years old and has not been reaffirmed, it is reasonable to conclude
22 that its contents, although still of some value, do not wholly reflect the present state of the art. Users are cautioned to check
23 to determine that they have the latest edition of any IEEE Standard.
24

25 In publishing and making this document available, the IEEE is not suggesting or rendering professional or other services
26 for, or on behalf of, any person or entity. Nor is the IEEE undertaking to perform any duty owed by any other person or
27 entity to another. Any person utilizing this, and any other IEEE Standards document, should rely upon the advice of a com-
28 petent professional in determining the exercise of reasonable care in any given circumstances.
29

30 Interpretations: Occasionally questions may arise regarding the meaning of portions of standards as they relate to specific
31 applications. When the need for interpretations is brought to the attention of IEEE, the Institute will initiate action to prepare
32 appropriate responses. Since IEEE Standards represent a consensus of concerned interests, it is important to ensure that any
33 interpretation has also received the concurrence of a balance of interests. For this reason, IEEE and the members of its soci-
34 eties and Standards Coordinating Committees are not able to provide an instant response to interpretation requests except in
35 those cases where the matter has previously received formal consideration.
36

37 Comments for revision of IEEE Standards are welcome from any interested party, regardless of membership affiliation with
38 IEEE. Suggestions for changes in documents should be in the form of a proposed change of text, together with appropriate
39 supporting comments. Comments on standards and requests for interpretations should be addressed to:
40

41
42
43 Secretary, IEEE-SA Standards Board
44 445 Hoes Lane
45 P.O. Box 1331
46 Piscataway, NJ 08855-1331
47 USA
48

49
50 **Note:** Attention is called to the possibility that implementation of this standard may require use of subject mat-
51 ter covered by patent rights. By publication of this standard, no position is taken with respect to the existence or
52 validity of any patent rights in connection therewith. The IEEE shall not be responsible for identifying patents
53 for which a license may be required by an IEEE standard or for conducting inquiries into the legal validity or
54 scope of those patents that are brought to its attention.
55

56 The IEEE and its designees are the sole entities that may authorize the use of the IEEE-owned certification marks and/or
57 trademarks to indicate compliance with the materials set forth herein. IEEE grants permission to print hard copies of the
58 forms in this document for purposes of documentation.
59

60 Authorization to photocopy portions of any individual standard for internal or personal use is granted by the Institute of
61 Electrical and Electronics Engineers, Inc., provided that the appropriate fee is paid to Copyright Clearance Center. To
62 arrange for payment of licensing fee, please contact Copyright Clearance Center, Customer Service, 222 Rosewood Drive,
63 Danvers, MA 01923 USA; +1 978 750 8400. Permission to photocopy portions of any individual standard for educational
64 classroom use can also be obtained through the Copyright Clearance Center.
65

Introduction

(This introduction is not part of IEEE Std 802.16/Conformance/03-2003, Draft Standard for Conformance to IEEE Standard 802.16 - Part 3: Radio Conformance Tests for 10-66 GHz WirelessMAN-SCTM Air Interface.)

This standard represents the Test Suite Structure and Test Purposes (TSS&TP), per ISO/IEC Standards 9646-1, and 9646-2 (1995) and ITU-T Standards X.290 and X.291, for conformance specification of base stations and subscriber stations based upon the WirelessMAN-SC (10-66 GHz) air interface specified in IEEE Std 802.16.

IEEE Std 802.16 is part of a family of standards for local and metropolitan area networks. The relationship between the standard and other members of the family is shown below. (The numbers in the figure refer to IEEE standard designations.¹)

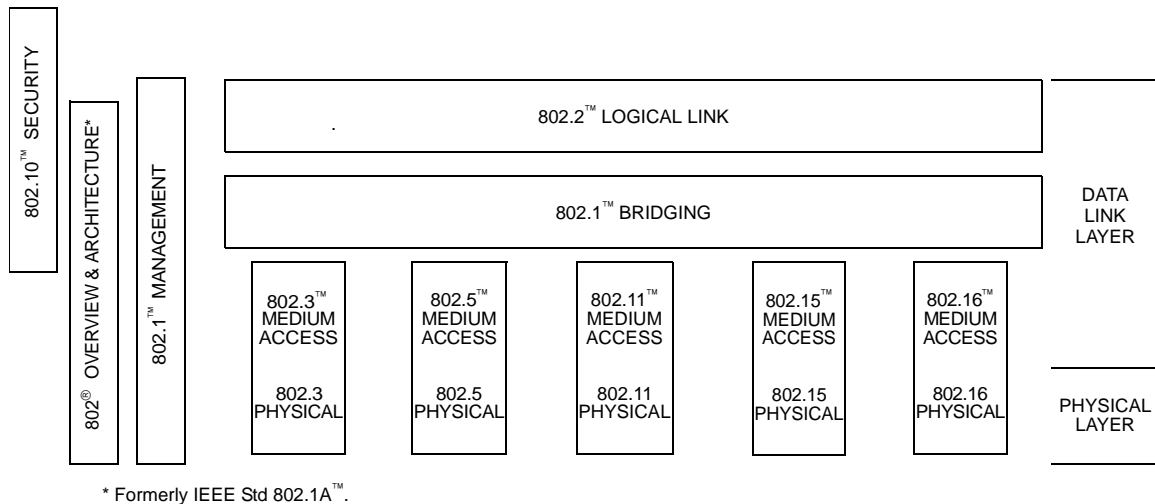

This family of standards deals with the Physical and Data Link Layers as defined by the International Organization for Standardization (ISO) Open Systems Interconnection Basic Reference Model (ISO/IEC 7498-1:1994). The access standards define several types of medium access technologies and associated physical media, each appropriate for particular applications or system objectives. Other types are under investigation.

The standards defining the technologies noted above are as follows:

- IEEE Std 802:² *Overview and Architecture.* This standard provides an overview to the family of IEEE 802 Standards. This document forms part of the IEEE Std 802.1 scope of work.
- IEEE Std 802.1B™ and 802.1k™ [ISO/IEC 15802-2]: *LAN/MAN Management.* Defines an Open Systems Interconnection (OSI) management-compatible architecture, and services and protocol elements for use in a LAN/MAN environment for performing remote management.

¹The IEEE standard designations referred to in the above figure and list are trademarks owned by the Institute of Electrical and Electronics Engineers, Incorporated.

²The IEEE 802 Overview and Architecture Specification, originally known as IEEE Std 802.1A, has been renumbered as IEEE Std 802. This has been done to accommodate recognition of the base standard in a family of standards. References to IEEE Std 802.1A should be considered as references to IEEE Std 802.

- 1 • IEEE Std 802.1D™ *Media Access Control (MAC) Bridges.* Specifies an
2 architecture and protocol for the [ISO/IEC 15802-3]:
3 interconnection of IEEE 802 LANs below the MAC service
4 boundary.
5
6
- 7 • IEEE Std 802.1E™ *System Load Protocol.* Specifies a set of services and protocol
8 [ISO/IEC 15802-4]: for those aspects of management concerned with the loading of
9 systems on IEEE 802 LANs.
10
11
- 12 • IEEE Std 802.1F™ *Common Definitions and Procedures for IEEE 802*
13 *Management Information.*
14
- 15 • IEEE Std 802.1G™ *Remote Media Access Control (MAC) Bridging.* Specifies
16 [ISO/IEC 15802-5]: extensions for the interconnection, using non-LAN systems
17 communication technologies, of geographically separated
18 IEEE 802 LANs below the level of the logical link control
19 protocol.
20
21
- 22 • IEEE Std 802.1H™ *Recommended Practice for Media Access Control (MAC)*
23 *Bridging of Ethernet V2.0 in IEEE 802 Local Area Networks.*
24 *Virtual Bridged Local Area Networks.* Defines an architecture
25 for Virtual Bridged LANs, the services provided in Virtual
26 Bridged LANs, and the protocols and algorithms involved in
27 the provision of those services.
28
29
- 30 • IEEE Std 802.2 [ISO/IEC 8802-2]: *Logical Link Control.*
31
32
- 33 • IEEE Std 802.3 [ISO/IEC 8802-3]: *CSMA/CD Access Method and Physical Layer Specifications.*
34
35
- 36 • IEEE Std 802.5 [ISO/IEC 8802-5]: *Token Ring Access Method and Physical Layer Specifications.*
37
38
- 39 • IEEE Std 802.10: *Standard for Interoperable LAN Security (SILS).* Currently
40 approved: Secure Data Exchange (SDE).
41
42
- 43 • IEEE Std 802.11: *Wireless LAN Medium Access Control (MAC) Sublayer and*
44 [ISO/IEC 8802-11] *Physical Layer Specifications.*
45
46
- 47 • IEEE Std 802.15: *Wireless Medium Access Control (MAC) and Physical Layer*
48 *(PHY) Specifications for: Wireless Personal Area Networks.*
49
50
- 51 • IEEE Std 802.16: *Air Interface for Fixed Broadband Wireless Access Systems.*
52

53 The reader of this standard is urged to become familiar with the complete family of standards.
54
55
56
57
58
59
60
61
62
63
64
65

Patents

Attention is called to the possibility that implementation of this standard may require use of subject matter covered by patent rights. By publication of this standard, no position is taken with respect to the existence or validity of any patent rights in connection therewith. The IEEE shall not be responsible for identifying patents for which a license may be required by an IEEE standard or for conducting inquiries into the legal validity or scope of those patents that are brought to its attention. A patent holder has filed a statement of assurance that it will grant licenses under these rights without compensation or under reasonable rates and nondiscriminatory, reasonable terms and conditions to all applicants desiring to obtain such licenses. The IEEE makes no representation as to the reasonableness of rates and/or terms and conditions of the license agreements offered by patent holders. Further information may be obtained from the IEEE Standards Department.

Conformance test methodology

Conformance test documents for the IEEE 802 family of standards are identified by either of two conventions. Single-part conformance documents are identified by the number 1802TM; for example, the conformance test documents for IEEE 802.3 are numbered 1802.3TM. Traditionally, ISO will use 18802 to number single-part conformance test standards for 8802 standards. Multipart conformance documents are identified by "/ConformanceXX". For example, the first part of the conformance specification for IEEE 802.16 would be designated IEEE 802.16/Conformance01.

Interpretations and errata

Interpretations and errata associated with this amendment may be found at one of the following Internet locations:

- <http://standards.ieee.org/reading/ieee/interp/>
- <http://standards.ieee.org/reading/ieee/updates/errata/>

Participants

This document was developed by the IEEE 802.16 Working Group on Broadband Wireless Access, which is responsible for Wireless Metropolitan Area Network (WirelessMAN™) Standards:

IEEE 802.16 Working Group Officers

Roger B. Marks, *Chair*

Carl Eklund, *Vice Chair*

Dean Chang, *Secretary*

Primary development was carried out by the Working Group's Task Group C:

Task Group C Officers

Kenneth Stanwood, *Chair*

Lars Lindh, *Technical Editor*

1 The following members of the IEEE 802.16 Working Group on Broadband Wireless Access participated in
2 the Working Group Letter Ballot in which the draft of this standard was approved:
3
4
5
6
7
8
9
10
11
12
13
14
15
16
17
18
19
20
21
22
23
24
25
26
27
28
29
30
31
32
33
34
35
36
37
38
39
40
41

42 The following members of the IEEE Balloting Committee voted on this standard, whether voting for
43 approval or disapproval, or abstaining.
44
45
46
47
48
49
50
51
52
53
54
55
56
57
58
59
60
61
62
63
64
65

Contents

1		
2		
3		
4	1. Introduction.....	1
5	2. Scope.....	1
6	3. Purpose.....	1
7	4. References.....	1
8	5. Definitions abbreviations.....	2
9	5.1 Definitions.....	2
10	5.2 Acronyms.....	2
11	6. Overview.....	2
12	6.1 General Requirements.....	3
13	6.2 Test Conditions.....	3
14	7. Environmental requirements.....	4
15	8. Required Tests.....	4
16	9. Test Procedures.....	6
17	9.1 Tests for the Subscriber Station.....	7
18	9.1.1 RS outer code t = 10 / BCC - frame control.....	7
19	9.1.1.1 Test setup.....	7
20	9.1.1.2 Test procedure.....	7
21	9.1.2 RS outer code other bursts.....	8
22	9.1.2.1 Test setup.....	8
23	9.1.2.2 Test procedure.....	8
24	9.1.3 Fixed codeword operation.....	9
25	9.1.3.1 Test setup.....	9
26	9.1.3.2 Test procedure.....	9
27	9.1.4 Shortened last codeword operation.....	10
28	9.1.4.1 Test setup.....	10
29	9.1.4.2 Test procedure.....	10
30	9.1.5 Burst preamble.....	11
31	9.1.5.1 Test setup.....	11
32	9.1.5.2 Test procedure.....	11
33	9.1.6 Modulation.....	12
34	9.1.6.1 Test setup.....	12
35	9.1.6.2 Test procedure.....	12
36	9.1.7 RS outer code - Information Block Length.....	13
37	9.1.7.1 Test setup.....	13
38	9.1.7.2 Test procedure.....	13
39	9.1.8 Randomization with programmable seed.....	14
40	9.1.8.1 Test setup.....	14
41	9.1.8.2 Test procedure.....	14
42	9.1.9 RS outer coder - Initial ranging.....	15
43	9.1.9.1 Test setup.....	15
44	9.1.9.2 Test procedure.....	15
45	9.1.10 RS outer code other bursts.....	16
46	9.1.10.1 Test setup.....	16
47	9.1.10.2 Test procedure.....	16
48	9.1.11 Fixed codeword operation.....	17
49	9.1.11.1 Test setup.....	17
50	9.1.11.2 Test procedure.....	17
51	9.1.12 Shortened last codeword operation.....	18
52	9.1.12.1 Test setup.....	18
53	9.1.12.2 Test procedure.....	18
54	9.1.13 BCC inner code.....	19
55		
56		
57		
58		
59		
60		
61		
62		
63		
64		
65		

1	9.1.13.1	Test setup	19
2	9.1.13.2	Test procedure.....	19
3	9.1.14	Burst preamble	20
4	9.1.14.1	Test setup	20
5	9.1.14.2	Test procedure.....	20
6	9.1.15	Modulation.....	21
7	9.1.15.1	Test setup	21
8	9.1.15.2	Test procedure.....	21
9	9.1.16	RS outer code - Information Block Length	22
10	9.1.16.1	Test setup	22
11	9.1.16.2	Test procedure.....	22
12	9.1.17	Tx Dynamic range	23
13	9.1.17.1	Test setup	23
14	9.1.17.2	Test procedure.....	23
15	9.1.18	Rx Dynamic range	24
16	9.1.18.1	Test setup	24
17	9.1.18.2	Test procedure.....	24
18	9.1.19	Tx Power level at maximum power level setting	25
19	9.1.19.1	Test setup	25
20	9.1.19.2	Test procedure.....	25
21	9.1.20	Tx Power level adjustment step accuracy	26
22	9.1.20.1	Test setup	26
23	9.1.20.2	Test procedure.....	26
24	9.1.21	Symbol timing accuracy	27
25	9.1.21.1	Test setup	27
26	9.1.21.2	Test procedure.....	27
27	9.1.22	Tx Burst timing	28
28	9.1.22.1	Test setup	28
29	9.1.22.2	Test procedure.....	28
30	9.1.23	Carrier frequency	29
31	9.1.23.1	Test setup	29
32	9.1.23.2	Test procedure.....	29
33	9.1.24	Spectral mask.....	30
34	9.1.24.1	Test setup	30
35	9.1.24.2	Test procedure.....	30
36	9.1.25	Ramp up / down time.....	31
37	9.1.25.1	Test setup	31
38	9.1.25.2	Test procedure.....	31
39	9.1.26	Output noise power spectral density when Tx is not transmitting.....	32
40	9.1.26.1	Test setup	32
41	9.1.26.2	Test procedure.....	32
42	9.1.27	Modulation accuracy.....	33
43	9.1.27.1	Test setup	33
44	9.1.27.2	Test procedure.....	33
45	9.1.28	BER performance threshold.....	34
46	9.1.28.1	Test setup	34
47	9.1.28.2	Test procedure.....	34
48	9.1.29	Transition time from Tx to Rx and from Rx to Tx	35
49	9.1.29.1	Test setup	35
50	9.1.29.2	Test procedure.....	35
51	9.1.30	1st adjacent channel interference	36
52	9.1.30.1	Test setup	36
53	9.1.30.2	Test procedure.....	36
54	9.1.31	2nd adjacent channel interference.....	38

1	9.1.31.1	Test setup	38
2	9.1.31.2	Test procedure.....	38
3	9.1.32	Tx Power level absolute accuracy	40
4	9.1.32.1	Test setup	40
5	9.1.32.2	Test procedure.....	40
6	9.2	Tests for the Base Station	41
7	9.2.1	RS outer code t = 10 / BCC - frame control	41
8	9.2.1.1	Test setup	41
9	9.2.1.2	Test procedure.....	41
10	9.2.2	RS outer code other bursts	42
11	9.2.2.1	Test setup	42
12	9.2.2.2	Test procedure.....	42
13	9.2.3	Fixed codeword operation	43
14	9.2.3.1	Test setup	43
15	9.2.3.2	Test procedure.....	43
16	9.2.4	Shortened last codeword operation.....	44
17	9.2.4.1	Test setup	44
18	9.2.4.2	Test procedure.....	44
19	9.2.5	Burst preamble	45
20	9.2.5.1	Test setup	45
21	9.2.5.2	Test procedure.....	45
22	9.2.6	Modulation.....	46
23	9.2.6.1	Test setup	46
24	9.2.6.2	Test procedure.....	46
25	9.2.7	RS outer code - Information Block Length	47
26	9.2.7.1	Test setup	47
27	9.2.7.2	Test procedure.....	47
28	9.2.8	Randomization with programmable seed	48
29	9.2.8.1	Test setup	48
30	9.2.8.2	Test procedure.....	48
31	9.2.9	RS outer code - Initial ranging.....	49
32	9.2.9.1	Test setup	49
33	9.2.9.2	Test procedure.....	49
34	9.2.10	RS outer code other bursts	50
35	9.2.10.1	Test setup	50
36	9.2.10.2	Test procedure.....	50
37	9.2.11	Fixed codeword operation	51
38	9.2.11.1	Test setup	51
39	9.2.11.2	Test procedure.....	51
40	9.2.12	Shortened last codeword operation.....	52
41	9.2.12.1	Test setup	52
42	9.2.12.2	Test procedure.....	52
43	9.2.13	BCC inner code.....	53
44	9.2.13.1	Test setup	53
45	9.2.13.2	Test procedure.....	53
46	9.2.14	Burst preamble	54
47	9.2.14.1	Test setup	54
48	9.2.14.2	Test procedure.....	54
49	9.2.15	Modulation.....	55
50	9.2.15.1	Test setup	55
51	9.2.15.2	Test procedure.....	55
52	9.2.16	RS outer code - Information Block Length	56
53	9.2.16.1	Test setup	56
54	9.2.16.2	Test procedure.....	56
55			
56			
57			
58			
59			
60			
61			
62			
63			
64			
65			

1	9.2.17	Channel allocation	57
2	9.2.17.1	Test setup	57
3	9.2.17.2	Test procedure.....	57
4	9.2.18	Symbol timing accuracy	58
5	9.2.18.1	Test setup	58
6	9.2.18.2	Test procedure.....	58
7	9.2.19	Carrier frequency	59
8	9.2.19.1	Test setup	59
9	9.2.19.2	Test procedure.....	59
10	9.2.20	Spectral mask.....	60
11	9.2.20.1	Test setup	60
12	9.2.20.2	Test procedure.....	60
13	9.2.21	Spurious	61
14	9.2.21.1	Test setup	61
15	9.2.21.2	Test procedure.....	61
16	9.2.22	Tx RMS Power level.....	62
17	9.2.22.1	Test setup	62
18	9.2.22.2	Test procedure.....	62
19	9.2.23	Ramp up / down time.....	63
20	9.2.23.1	Test setup	63
21	9.2.23.2	Test procedure.....	63
22	9.2.24	Modulation accuracy.....	64
23	9.2.24.1	Test setup	64
24	9.2.24.2	Test procedure.....	64
25	9.2.25	Rx Dynamic range	65
26	9.2.25.1	Test setup	65
27	9.2.25.2	Test procedure.....	65
28	9.2.26	BER performance threshold.....	66
29	9.2.26.1	Test setup	66
30	9.2.26.2	Test procedure.....	66
31	9.2.27	1st adjacent channel interference	67
32	9.2.27.1	Test setup	67
33	9.2.27.2	Test procedure.....	67
34	9.2.28	2nd adjacent channel interference.....	69
35	9.2.28.1	Test setup	69
36	9.2.28.2	Test procedure.....	69
37			
38			
39			
40			
41			
42			
43			
44			
45	Annex A	70
46			
47			
48	A.1	Recommendations for the test laboratories.....	70
49	A.1.1	Antenna input connectors	70
50	A.1.2	Test equipment.....	71
51			
52	A.2	General test platform	71
53			
54			
55	A.3	Carrier frequencies.....	71
56			
57			
58			
59			
60			
61			
62			
63			
64			
65			

List of Tables

1
2
3
4
5
6
7
8
9
10
11
12
13
14
15
16
17
18
19
20
21
22
23
24
25
26
27
28
29
30
31
32
33
34
35
36
37
38
39
40
41
42
43
44
45
46
47
48
49
50
51
52
53
54
55
56
57
58
59
60
61
62
63
64
65

Table 1—Required tests.....	4
Table 2—Spectrum analyzer settings	30
Table 3—EVM requirements.....	33
Table 4—BER performance threshold sensitivity values.....	34
Table 5—1st adjacent channel interference BER10-3.....	37
Table 6—1st adjacent channel interference BER=10-6.....	37
Table 7—2nd adjacent channel interference BER10-3.....	39
Table 8—2nd adjacent channel interference BER=10-6.....	39
Table 9—Spectrum analyzer settings	60
Table 10—Spectrum analyzer settings	61
Table 11—EVM requirements.....	64
Table 12—BER performance threshold sensitivity values.....	66
Table 13—1st adjacent channel interference BER10-3.....	68
Table 14—1st adjacent channel interference BER=10-6.....	68
Table 15—2nd adjacent channel interference BER10-3.....	70
Table 16—2nd adjacent channel interference BER=10-6.....	70
Table 17—Recommended antenna wave guide connectors	71

1. Introduction

To evaluate conformance of a particular implementation of a radio interface, it is necessary to have a common radio testing document with common radio test procedures as outlined in the Test Suite Structure and Test Purposes (TSS&TP) document. The Radio Conformance Test (RCT) specification document serves this purpose.

2. Scope

This document is a specification for the radio conformance test of the 802.16 PHY layer.

The scope of the document is as follows:

It specifies the test procedures and the test conditions in order to ensure conformance to the standard and to guarantee interoperability between equipment developed by different manufacturers. This is achieved by testing the baseband and RF signal processing functionalities in the transmitter and the receiver. The specification covers basic RF aspects, including the radio frequency channel plans and those other parameters necessary for radio regulatory coexistence purposes.

The tests correspond to the requirements in the Test Purposes in the IEEE 802.16 10–66 GHz conformance testing. Sub-part 2: "Test Suite Structure and Test Purposes (TSS & TP) Specification". The requirements are given in conjunction with the tests.

Requirements for the test laboratories are given in Annex A

3. Purpose

In order to ensure interoperability between the equipment built by different manufacturers from the PHY-perspective and compliance with IEEE Std 802.16-2001: "Local and Metropolitan Area Networks – Part 16: Standard Air Interface for Fixed Wireless Access Systems", standardized conformance test procedures for the PHY specifications are specified. However, for supporting these test procedure some basic functionalities from the MAC layer are required.

In order to perform these tests some dedicated test equipment and testing capabilities are required by the test laboratories.

4. References

The following documents contain provisions, which, through reference in this text, constitute provisions of the present document.

References are either specific (identified by date of publication, edition number, version number, etc.) or non-specific. For a specific reference, subsequent revisions do not apply.

For non-specific references, the latest versions apply.

- [1] IEEE Std 802.16-2001: "Local and Metropolitan Area Networks – Part 16: Standard Air Interface-for Fixed Wireless Access Systems"

The general block diagram of the 802.16 downlink and uplink system is illustrated in Figure 1.

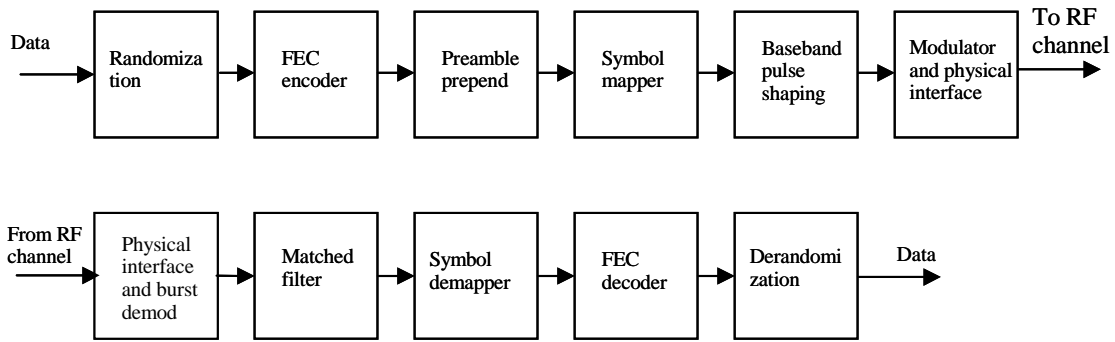

Figure 1—PHY layer conceptual block diagram

6.1 General Requirements

The general block-diagram with naming of test interfaces is given in Figure 2. The block diagram describes only conceptually the main system components and interfaces, and does not dictate any implementation. The manufacturer shall during the testing occasion make the signals in the listed interfaces available for measurements.

The following abbreviations have been used:

- A: Antenna interface
- M: MAC interface
- SC: Symbol Clock interface

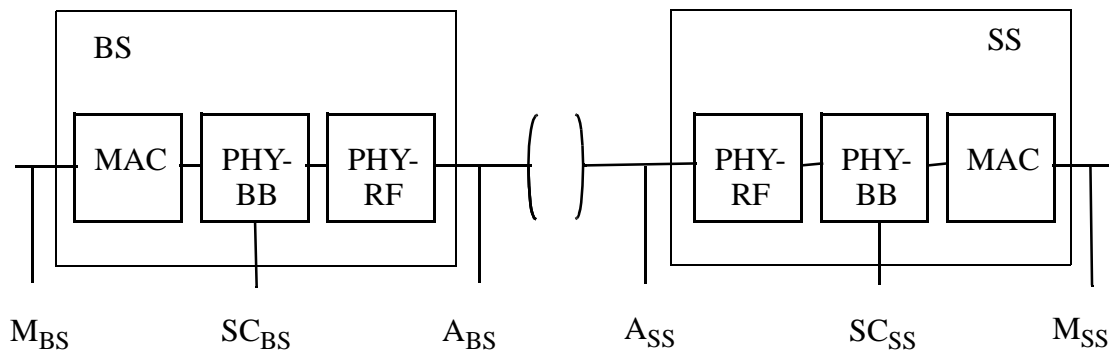

Figure 2—General block diagram

6.2 Test Conditions

7. Environmental requirements

8. Required Tests

The required tests are described in the IEEE 802.16 10–66 GHz conformance testing. Sub-part 2: "Test Suite Structure and Test Purposes (TSS & TP) Specification" [7] and listed in table 1. Test Procedures

Table 1—Required tests

	Mandatory	Optional
Parameters for the Subscriber Station		
Downlink		
RS outer code t = 10 / BCC - frame control	M	
RS outer code other bursts	M	
Fixed codeword operation	M	
Shortened last codeword operation	M	
Burst preamble	M	
Modulation	M	
RS outer code - information block length	M	
Uplink		
Randomization with programmable seed	M	
RS outer coder - initial ranging	M	
RS outer code other bursts	M	
Fixed codeword operation	M	
Shortened last codeword operation	M	
BCC inner code	M	
Burst preamble	M	
Modulation	M	
RS outer code - information block length	M	
Minimum performance		
Channel allocation	M	
Transmitter dynamic range	M	
Receiver dynamic range	M	
Transmitter RMS power level at maximum power level setting	M	
Transmitter power level adjustment step accuracy	M	
Symbol timing accuracy	M	
Transmitter burst timing	M	
Carrier frequency	M	

Table 1—Required tests (continued)

Spectral mask	M	
Ramp up / ramp down	M	
Output noise power spectral density	M	
Modulation accuracy	M	
BER performance threshold	M	
Transition time from Tx to Rx and from Rx to Tx	M	
1st adjacent channel interference	M	
2nd adjacent channel interference	M	
Parameters for the Base Station		
Downlink		
RS outer code $t = 10$ / BCC - frame control	M	
RS outer code other bursts	M	
Fixed codeword operation	M	
Shortened last codeword operation	M	
Burst preamble	M	
Modulation	M	
RS outer code - information block length	M	
Uplink		
Randomization with programmable seed	M	
RS outer coder - initial ranging	M	
RS outer code other bursts	M	
Fixed codeword operation	M	
Shortened last codeword operation	M	
BCC inner code	M	
Burst preamble	M	
Modulation	M	
RS outer code - information block length	M	
Minimum performance		
Channel allocation	M	
Symbol timing accuracy	M	

Table 1—Required tests (continued)

Carrier frequency	M	
Spectral mask	M	
Spurious	M	
Transmitter RMS power level	M	
Ramp up / ramp down	M	
Modulation accuracy	M	
Receiver dynamic range	M	
BER performance threshold	M	
1st adjacent channel interference	M	
2nd adjacent channel interference	M	

9. Test Procedures

Some test procedures assume that the counterpart for the IUT, denoted “Test BS”, “Test SS” or “Tester”, has some additional features not mandated by the 802.16 standard. These features are solely there to aid the test procedures. Typical tester functions are: capability to eject gating signals for the measurement instruments, special software for requesting a special behaviour of the IUT. The Tester also has significantly better and known output signal quality than the IUT.

9.1 Tests for the Subscriber Station

9.1.1 RS outer code $t = 10$ / BCC - frame control

9.1.1.1 Test setup

Figure 3 shows the test setup for testing the RS outer code $t = 10$ / BCC - frame control.

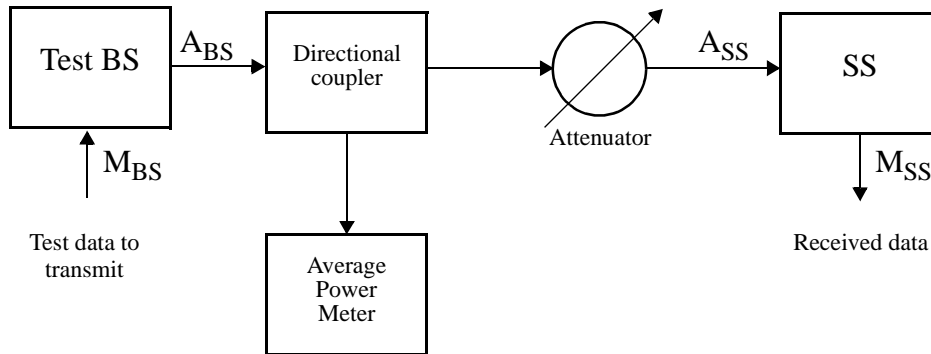

Figure 3—Test setup for RS outer code $t = 10$ / BCC - frame control

Instruments needed: Directional coupler
 Attenuator
 Average power meter

9.1.1.2 Test procedure

The losses for the coupler and the connecting waveguides are measured and the attenuator is calibrated. When measuring the power the losses, the effect of the coupler and the duty cycle shall be taken into account.

A connection is setup between the Test BS and the SS. The Test BS is setup to send data consisting of frames filled with QPSK modulated data and coded with Block Convolutional Code + Reed Solomon $t = 4$. The number of information bytes in a RS block shall be 128. The data received at the SS is compared with the transmitted data.

The attenuator is adjusted until the received power is $-98 + 10\log(B)$ dBm, where B is the symbol rate in MBaud.

The bit error rate (BER) is measured at the SS from the payload of the accepted packets and shall be less than $1.12 \cdot 10^{-7}$. This test procedure, using the FEC, is in conformance with the BER requirement of uncoded QPSK in the base specification [1]. The fact that the packets are received correctly proves that the decoding of the frame control portion, BCC + Reed-Solomon $t=10$, works correctly. The measured BER is another proof of that the BCC decoding works satisfactorily.

9.1.2 RS outer code other bursts

9.1.2.1 Test setup

Figure 4 shows the test setup for testing the RS outer code other bursts.

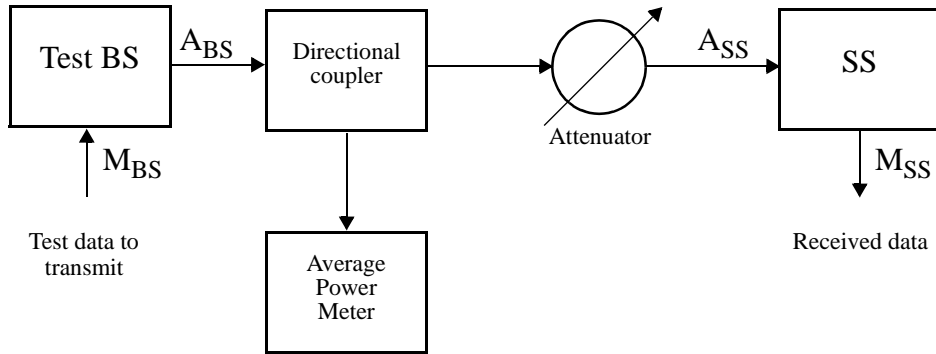

Figure 4—Test setup for RS outer code other bursts

Instruments needed:

- Directional coupler
- Attenuator
- Average power meter

9.1.2.2 Test procedure

The losses for the coupler and the connecting waveguides are measured and the attenuator is calibrated. When measuring the power the losses, the effect of the coupler and the duty cycle shall be taken into account.

A connection is setup between the Test BS and the SS. The Test BS transmits the bursts with QPSK modulation, no BCC coding, RS coding with $t = 0, 4, 8$ and 12 , and information bytes = 128 .

The downlink frame is filled with bursts of test data. The received power is adjusted until the S/N is approximately 10 dB above the actual threshold to ensure the quality of the signal. The data received at the SS is checked for correctness.

The Test BS inserts alternatively $0, 4, 8$ or 12 erroneous bytes in the codeword corresponding to $t = 0, 4, 8$ and 12 . The SS shall receive the data correctly.

The Test BS inserts alternatively $1, 5, 9$ or 13 erroneous bytes in the codeword corresponding to $t = 0, 4, 8$ and 12 . The SS shall not be able to receive the data correctly.

9.1.3 Fixed codeword operation

9.1.3.1 Test setup

Figure 5 shows the test setup for testing the RS fixed codeword operation.

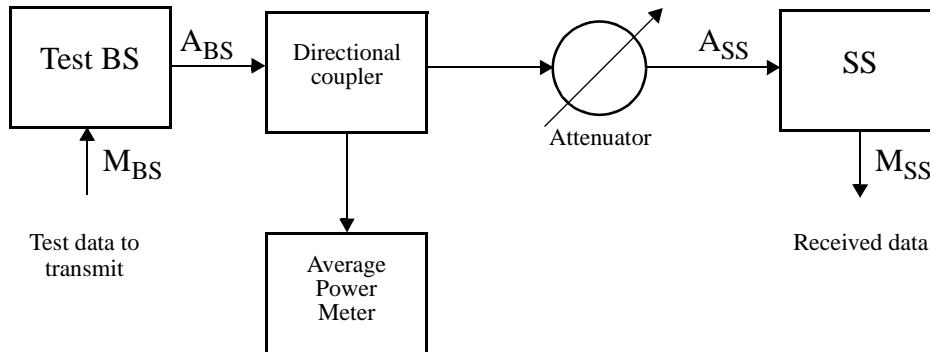

Figure 5—Test setup for Fixed codeword operation

Instruments needed:

- Directional coupler
- Attenuator
- Average power meter

9.1.3.2 Test procedure

The losses for the coupler and the connecting waveguides are measured and the attenuator is calibrated. When measuring the power the losses, the effect of the coupler and the duty cycle shall be taken into account.

A connection is setup between the Test BS and the SS. The Test BS transmits the bursts with Reed-Solomon using Fixed codeword option, QPSK modulation, no BCC coding, RS coding with $t = 8$ and information bytes = 128.

The downlink frame is filled with bursts of test data. The number of bytes in the downlink frame must be not be a multiple of 128. The received power is adjusted until the S/N is approximately 10 dB above the actual threshold to ensure the quality of the signal.

The SS receives the data correctly.

9.1.4 Shortened last codeword operation

9.1.4.1 Test setup

Figure 6 shows the test setup for testing the RS shortened codeword operation.

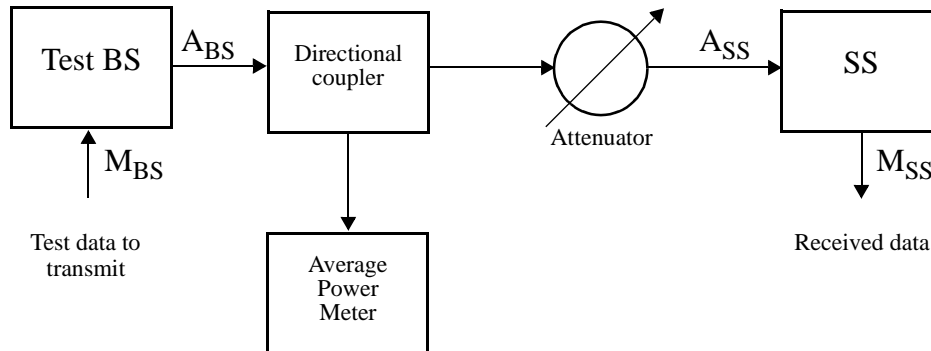

Figure 6—Test setup for Shortened codeword operation

Instruments needed:

- Directional coupler
- Attenuator
- Average power meter

9.1.4.2 Test procedure

The losses for the coupler and the connecting waveguides are measured and the attenuator is calibrated. When measuring the power the losses, the effect of the coupler and the duty cycle shall be taken into account.

A connection is setup between the Test BS and the SS. The Test BS transmits the bursts with Reed-Solomon using Shortened codeword option, QPSK modulation, no BCC coding, RS coding with $t = 8$ and information bytes = 128.

The downlink frame is filled with bursts of test data. The number of bytes in the downlink frame must be not be a multiple of 128. The received power is adjusted until the S/N is approximately 10 dB above the actual threshold to ensure the quality of the signal.

The SS receives the data correctly.

9.1.5 Burst preamble

9.1.5.1 Test setup

Figure 7 shows the test setup for testing the burst preamble.

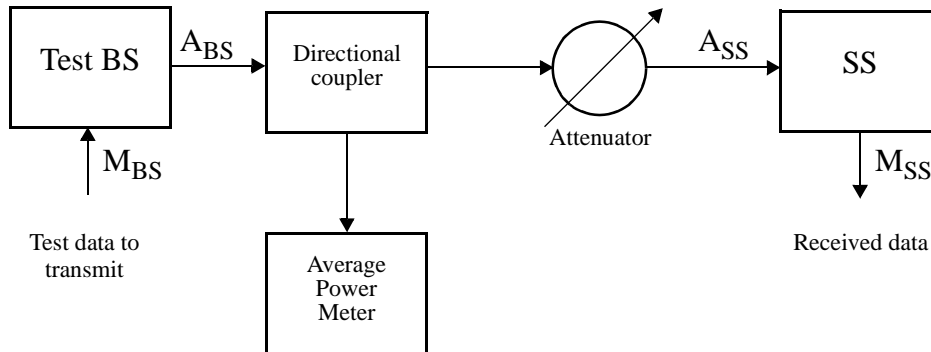

Figure 7—Test setup for burst preamble

Instruments needed:

- Directional coupler
- Attenuator
- Average power meter

9.1.5.2 Test procedure

The losses for the coupler and the connecting waveguides are measured and the attenuator is calibrated. When measuring the power the losses, the effect of the coupler and the duty cycle shall be taken into account.

A connection is setup between the Test BS and the SS. The Test BS is setup to transmit data in the TDMA portion of the frame.

The downlink frame is filled with bursts of test data. The received power is adjusted until the S/N is approximately 10 dB above the actual threshold to ensure the quality of the signal.

The SS receives the data correctly.

The fact that the SS receives the data correctly proves that the SS is able to synchronize to burst preambles, which are in the beginning of each TDMA burst.

9.1.6 Modulation

9.1.6.1 Test setup

Figure 8 shows the test setup for testing the modulation.

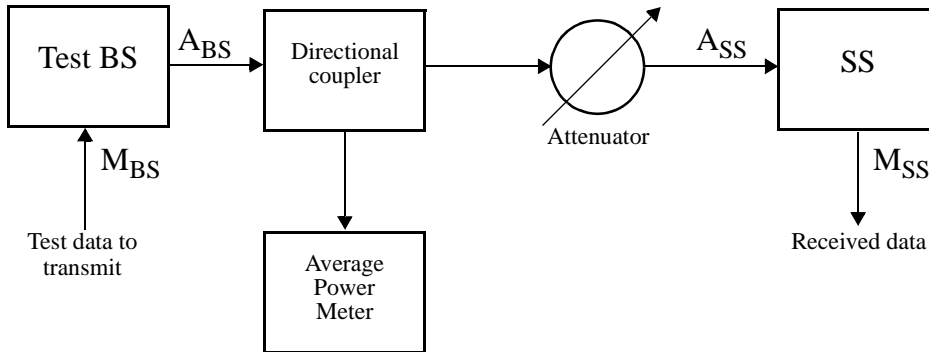

Figure 8—Test setup for modulation

Instruments needed:

- Directional coupler
- Attenuator
- Average power meter

9.1.6.2 Test procedure

The losses for the coupler and the connecting waveguides are measured and the attenuator is calibrated. When measuring the power the losses, the effect of the coupler and the duty cycle shall be taken into account.

A connection is setup between the Test BS and the SS. The Test BS is setup to transmit data in the TDM and TDMA portions of the frame with all modulation schemes supported by the SS.

The downlink frame is filled with bursts of test data. The received power is adjusted until the S/N is approximately 10 dB above the actual threshold to ensure the quality of the signal.

The SS receives the data correctly.

9.1.7 RS outer code - Information Block Length

9.1.7.1 Test setup

Figure 9 shows the test setup for testing the RS outer code - Information Block Length.

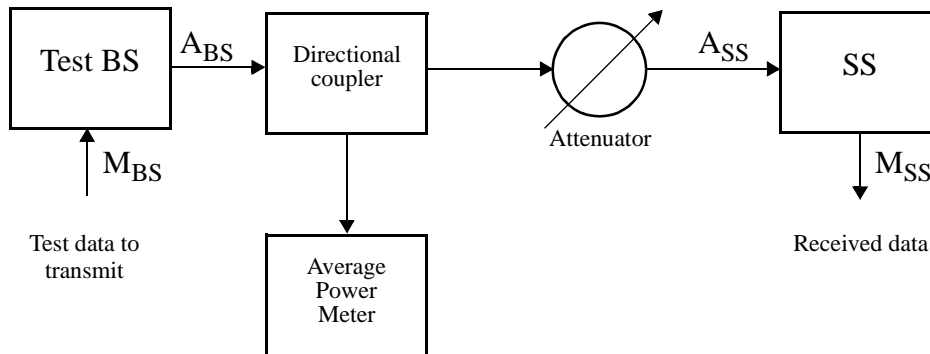

Figure 9—Test setup for RS outer code - Information Block Length

Instruments needed:

- Directional coupler
- Attenuator
- Average power meter

9.1.7.2 Test procedure

The losses for the coupler and the connecting waveguides are measured and the attenuator is calibrated. When measuring the power the losses, the effect of the coupler and the duty cycle shall be taken into account.

A connection is setup between the Test BS and the SS. QPSK modulation, no BCC coding, RS coding with information block length = 6, 128, 239 and $t = 8$ are used.

The downlink frame is filled with bursts of test data. The received power is adjusted until the S/N is approximately 10 dB above the actual threshold to ensure the quality of the signal.

The SS shall receive the data correctly.

9.1.8 Randomization with programmable seed

9.1.8.1 Test setup

Figure 10 shows the test setup for randomization with programmable seed.

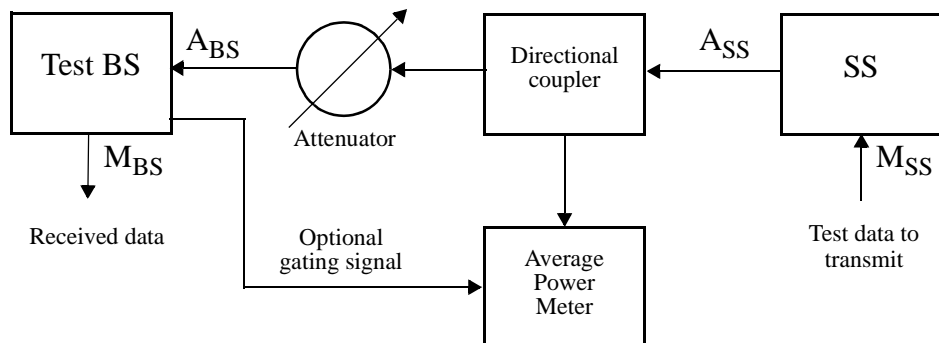

Figure 10—Test setup for randomization with programmable seed

Instruments needed:

- Directional coupler
- Attenuator
- Average power meter

9.1.8.2 Test procedure

The losses for the coupler and the connecting waveguides are measured and the attenuator is calibrated. When measuring the power the losses, the effect of the coupler and the duty cycle shall be taken into account.

A connection is setup between the Test BS and the SS. The Test BS commands the SS to use burst profiles with different seed values for the randomization.

Data is transmitted in the uplink.

The Test BS shall receive the data correctly.

9.1.9 RS outer coder - Initial ranging

9.1.9.1 Test setup

Figure 11 shows the test setup for testing the RS outer code - Initial ranging.

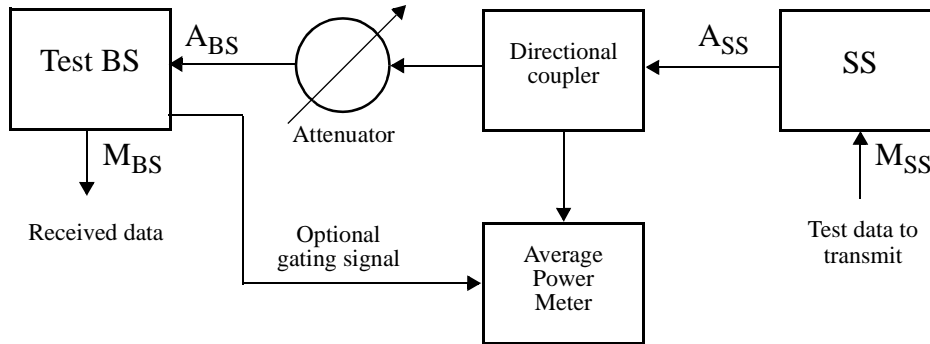

Figure 11—Test setup for RS outer code - Initial ranging

Instruments needed:

- Directional coupler
- Attenuator
- Average power meter

9.1.9.2 Test procedure

The losses for the coupler and the connecting waveguides are measured and the attenuator is calibrated. When measuring the power the losses, the effect of the coupler and the duty cycle shall be taken into account.

A connection is setup between the Test BS and the SS.

The Test BS commands the SS to use burst profiles with RS parameter $t = 10$ for initial ranging.

The SS sends a RNG-REQ message in the initial ranging opportunity. The Test BS receives the data correctly.

9.1.10 RS outer code other bursts

9.1.10.1 Test setup

Figure 12 shows the test setup for testing the RS outer code other bursts.

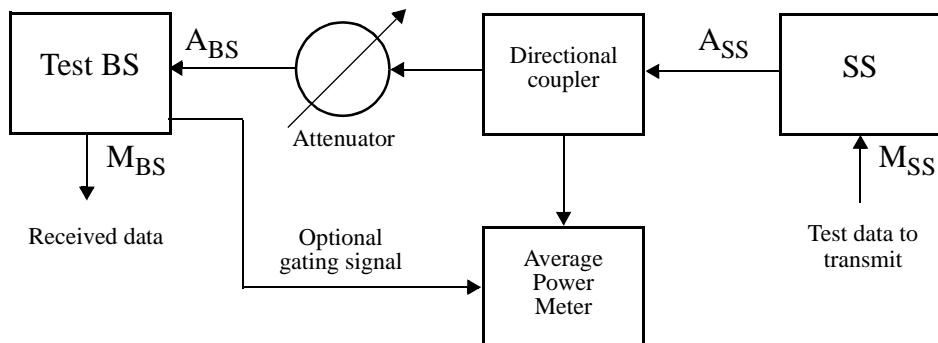

Figure 12—Test setup for RS outer code other bursts

Instruments needed:

- Directional coupler
- Attenuator
- Average power meter

9.1.10.2 Test procedure

The losses for the coupler and the connecting waveguides are measured and the attenuator is calibrated. When measuring the power the losses, the effect of the coupler and the duty cycle shall be taken into account.

A connection is setup between the Test BS and the SS. The Test BS commands the SS to use burst profiles with the RS parameter $t = 0, 4, 8$ or 12 , and information bytes 128 are used.

Data is transmitted in the uplink

The Test BS receives the data correctly.

9.1.11 Fixed codeword operation

9.1.11.1 Test setup

Figure 13 shows the test setup for testing the RS fixed codeword operation.

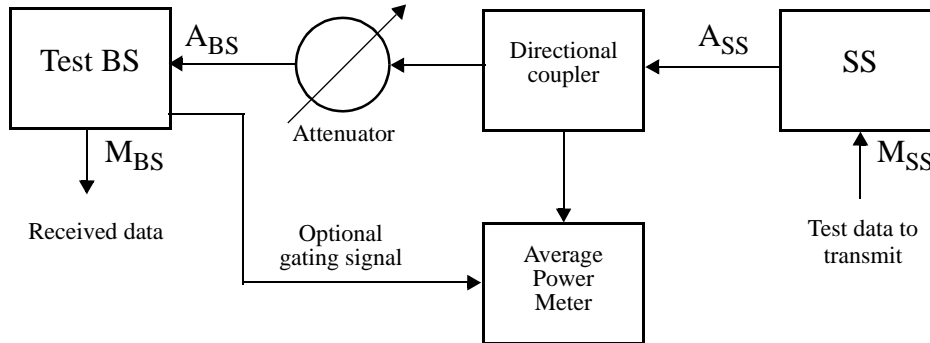

Figure 13—Test setup for Fixed codeword operation

Instruments needed:

- Directional coupler
- Attenuator
- Average power meter

9.1.11.2 Test procedure

The losses for the coupler and the connecting waveguides are measured and the attenuator is calibrated. When measuring the power the losses, the effect of the coupler and the duty cycle shall be taken into account.

A connection is setup between the Test BS and the SS. The Test BS commands the SS to use burst profiles with Reed-Solomon Fixed codeword option, QPSK modulation, no BCC coding, RS coding with $t = 8$ and information bytes = 128 in all uplink bursts. The number of bytes in the downlink frame must be not be a multiple of 128.

Data is transmitted in the uplink.

The Test BS receives the data correctly.

9.1.12 Shortened last codeword operation

9.1.12.1 Test setup

Figure 14 shows the test setup for testing the RS shortened codeword operation.

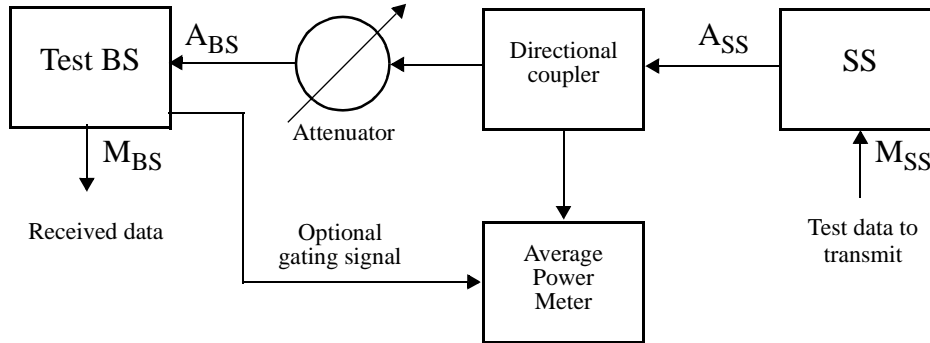

Figure 14—Test setup for Shortened codeword operation

Instruments needed:

- Directional coupler
- Attenuator
- Average power meter

9.1.12.2 Test procedure

The losses for the coupler and the connecting waveguides are measured and the attenuator is calibrated. When measuring the power the losses, the effect of the coupler and the duty cycle shall be taken into account.

A connection is setup between the Test BS and the SS. The Test BS commands the SS to use burst profiles with Reed-Solomon Shortened codeword, QPSK modulation, no BCC coding, RS coding with $t = 8$ and information bytes = 128 in all uplink bursts. The number of bytes in the downlink frame must be not be a multiple of 128.

Data is transmitted in the uplink.

The Test BS receives the data correctly.

9.1.13 BCC inner code

9.1.13.1 Test setup

Figure 15 shows the test setup for testing the BCC innercode operation.

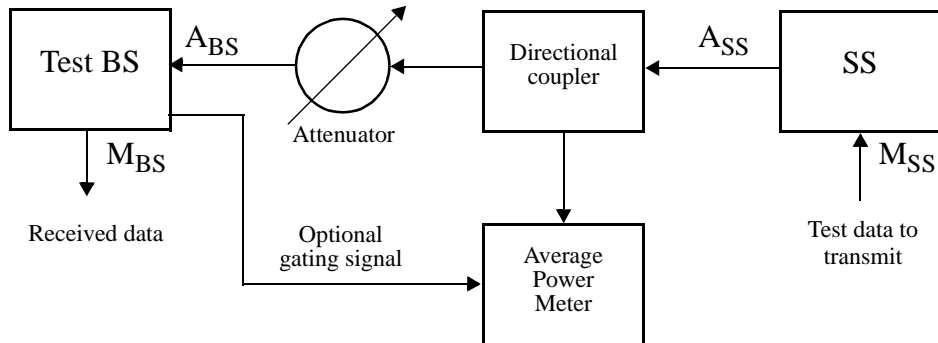

Figure 15—Test setup for BCC inner code operation

Instruments needed: Directional coupler
 Attenuator
 Average power meter

9.1.13.2 Test procedure

The losses for the coupler and the connecting waveguides are measured and the attenuator is calibrated. When measuring the power the losses, the effect of the coupler and the duty cycle shall be taken into account.

A connection is setup between the Test BS and the SS. The Test BS commands the SS to use burst profiles with BCC inner code in all uplink bursts.

Data is transmitted in the uplink.

The Test BS receives the data correctly.

9.1.14 Burst preamble

9.1.14.1 Test setup

Figure 16 shows the test setup for testing the burst preamble.

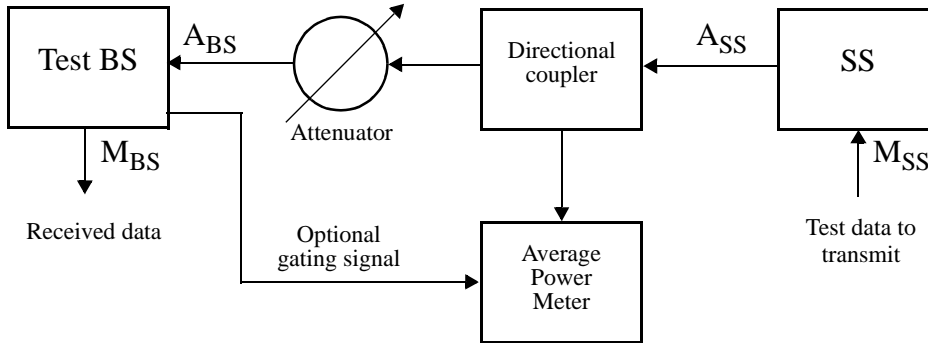

Figure 16—Test setup for burst preamble

Instruments needed:

- Directional coupler
- Attenuator
- Average power meter

9.1.14.2 Test procedure

The losses for the coupler and the connecting waveguides are measured and the attenuator is calibrated. When measuring the power the losses, the effect of the coupler and the duty cycle shall be taken into account.

A connection is setup between the Test BS and the SS. The Test BS commands the SS to use burst profiles with different preamble lengths in the uplink bursts.

Data is transmitted in the uplink.

The Test BS receives the data correctly.

9.1.15 Modulation

9.1.15.1 Test setup

Figure 17 shows the test setup for testing the modulation schemes.

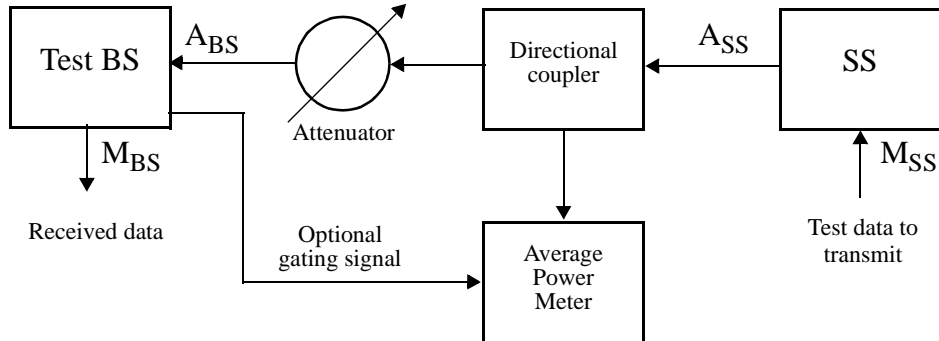

Figure 17—Test setup for the modulation schemes

Instruments needed:

- Directional coupler
- Attenuator
- Average power meter

9.1.15.2 Test procedure

The losses for the coupler and the connecting waveguides are measured and the attenuator is calibrated. When measuring the power the losses, the effect of the coupler and the duty cycle shall be taken into account.

A connection is setup between the Test BS and the SS. The Test BS commands the SS to use burst profiles with the different modulation schemes supported by the SS in the uplink bursts.

Data is transmitted in the uplink.

The Test BS receives the data correctly.

9.1.16 RS outer code - Information Block Length

9.1.16.1 Test setup

Figure 18 shows the test setup for testing the RS outer code - Information Block Length.

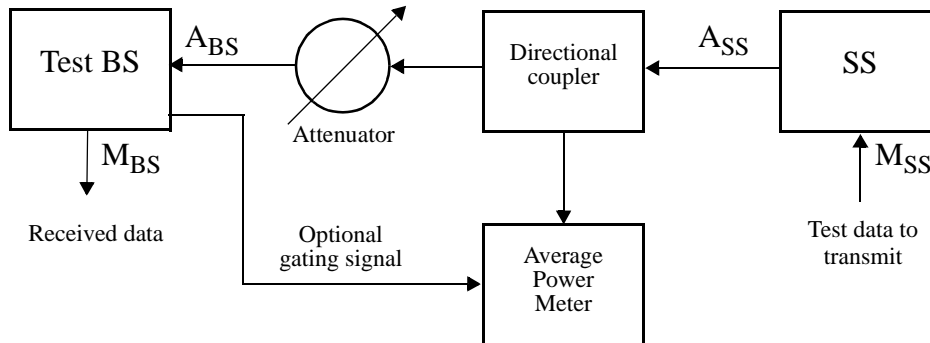

Figure 18—Test setup for RS outer code - Information Block Length

Instruments needed:

- Directional coupler
- Attenuator
- Average power meter

9.1.16.2 Test procedure

The losses for the coupler and the connecting waveguides are measured and the attenuator is calibrated. When measuring the power the losses, the effect of the coupler and the duty cycle shall be taken into account.

A connection is setup between the Test BS and the SS. The Test BS commands the SS to use burst profiles with the the RS parameter Information block length = 6, 128 and 239. RS parameter $t = 8$.

Data is transmitted in the uplink.

The Test BS receives the data correctly.

9.1.17 Tx Dynamic range

9.1.17.1 Test setup

Figure 19 shows the test setup for testing the Tx Dynamic Range

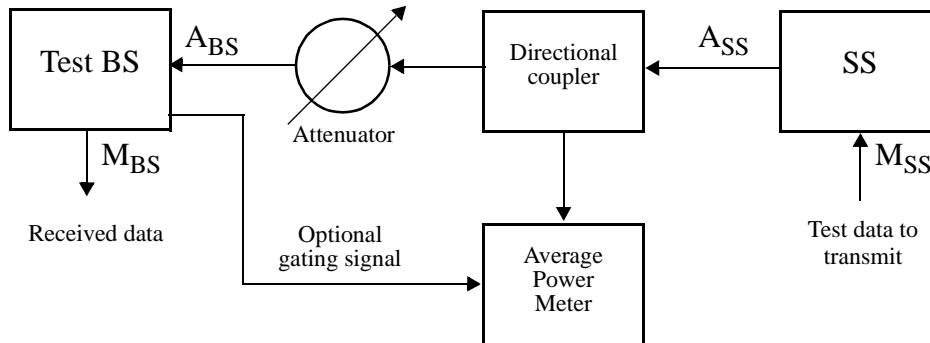

Figure 19—Test setup for Tx Dynamic Range

Instruments needed:

- Directional coupler
- Attenuator
- Average power meter

9.1.17.2 Test procedure

The losses for the coupler and the connecting waveguides are measured and the attenuator is calibrated. When measuring the power the losses, the effect of the coupler and the duty cycle shall be taken into account.

A connection is setup between the Test BS and the SS. The Test BS commands the SS to use QPSK modulation, Block Convolutional Code and Reed Solomon parameter $t = 8$. The number of information bytes in a RS block shall be 128 and the burst length shall be constant. Data is transmitted in the uplink.

The attenuator is slowly adjusted to its lowest value and as a consequence the SS shall decrease its transmit power until the minimum operable value is achieved. The transmitted power is measured and recorded. The attenuator is then slowly increased until the SS reaches its maximum operable value. The transmitted power is measured and recorded.

The difference between the two power values is the Tx dynamic range and shall be ≥ 40 dB.

9.1.18 Rx Dynamic range

9.1.18.1 Test setup

Figure 20 shows the test setup for testing the Rx Dynamic Range

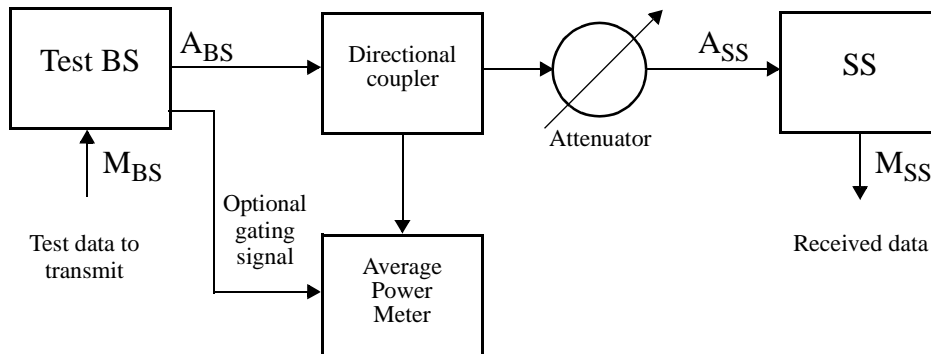

Figure 20—Test setup for Rx Dynamic Range

Instruments needed:

- Directional coupler
- Attenuator
- Average power meter

9.1.18.2 Test procedure

The losses for the coupler and the connecting waveguides are measured and the attenuator is calibrated. When measuring the power the losses, the effect of the coupler and the duty cycle shall be taken into account.

A connection is setup between the Test BS and the SS. The Test BS commands the SS to use the most robust burst profile. Data is transmitted in the downlink.

The attenuator is slowly adjusted to its lowest operable value. The power of the received signal is measured and recorded. The attenuator is then slowly increased until the the maximum operable value is reached. The power is measured and recorded.

The difference between the two power values is the Rx dynamic range and shall be ≥ 40 dB.

9.1.19 Tx Power level at maximum power level setting

9.1.19.1 Test setup

Figure 19 shows the test setup for testing the Tx Power level at maximum power level setting

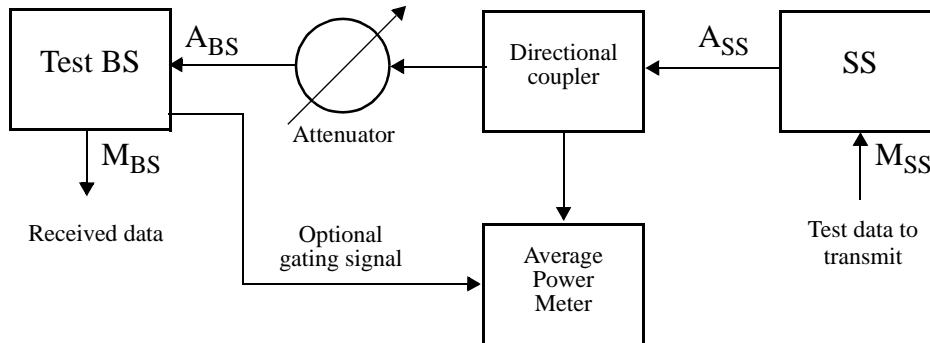

Figure 21—Test setup for Tx Power at maximum power level setting

Instruments needed:

- Directional coupler
- Attenuator
- Average power meter

9.1.19.2 Test procedure

The losses for the coupler and the connecting waveguides are measured and the attenuator is calibrated. When measuring the power the losses, the effect of the coupler and the duty cycle shall be taken into account.

A connection is setup between the Test BS and the SS. The Test BS commands the SS to use the most robust burst profile. Data is transmitted in the uplink.

The attenuator is slowly adjusted towards its highest value until the SS increases its transmit power to its maximum. The Test BS shall receive the data correctly. The power is measured

The power shall be ≥ 15 dBm.

9.1.20 Tx Power level adjustment step accuracy

9.1.20.1 Test setup

Figure 22 shows the test setup for testing the Tx Power level adjustment step accuracy.

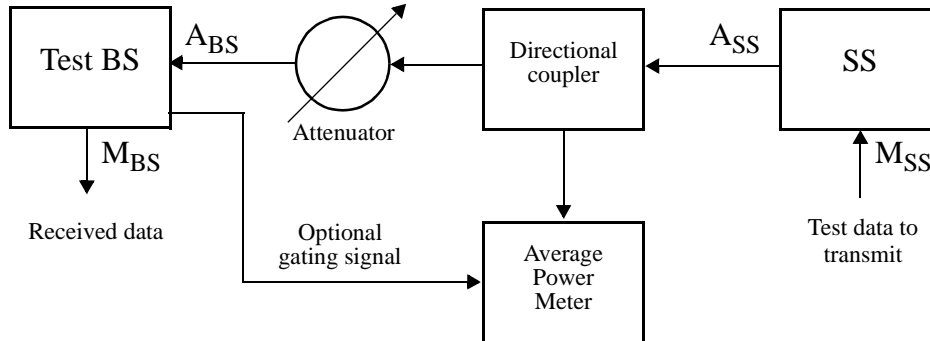

Figure 22—Test setup for Tx Power level step adjustment step accuracy

Instruments needed:

- Directional coupler
- Attenuator
- Average power meter

9.1.20.2 Test procedure

The losses for the coupler and the connecting waveguides are measured and the attenuator is calibrated. When measuring the power the losses, the effect of the coupler and the duty cycle shall be taken into account.

A connection is setup between the Test BS and the SS. The Test BS commands the SS to use the most robust burst profile at the bottom, medium and top values of the transmit power range. Data is transmitted in the uplink. The transmit power is measured

The Test BS commands the SS to adjust its transmit power level with the step sizes +/- [0.5 - 2.0] dB, +/- [2 - 5] dB and > +/- 5 dB.

The measured change in power shall be monotonically positive (negative), +/- 2 dB of the requested change, +/- 5 dB of the requested change.

9.1.21 Symbol timing accuracy

9.1.21.1 Test setup

Figure 23 shows the test setup for testing the symbol timing accuracy.

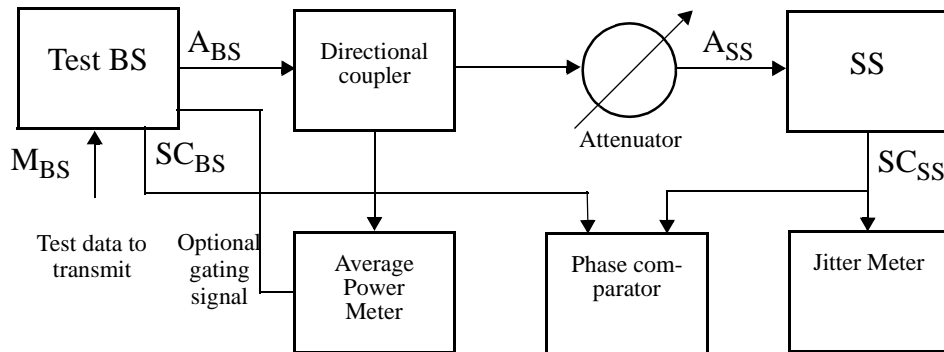

Figure 23—Test setup for symbol timing accuracy

Instruments needed:

- Directional coupler
- Average power meter
- Attenuator
- Jitter meter
- Phase comparator

9.1.21.2 Test procedure

The losses for the coupler and the connecting waveguides are measured and the attenuator is calibrated. When measuring the power the losses, the effect of the coupler and the duty cycle shall be taken into account.

A connection is setup between the Test BS and the SS but no data is transmitted in the downlink so the downlink consists only of the control portion. The signal is adjusted until the received power is $-98 + 10\log(B)$ dBm, where B is the symbol rate in MBaud, in order to correspond to a worst case signal.

The jitter of the SS symbol clock is measured. Peak-to-peak jitter during a 2 sec measurement period must be less than 2 %.

The symbol clock of the Test BS and SS are connected to a phase comparator. The SS shall be locked to the Test BS symbol clock.

9.1.22 Tx Burst timing

9.1.22.1 Test setup

Figure 24 shows the test setup for testing the Tx Burst timing.

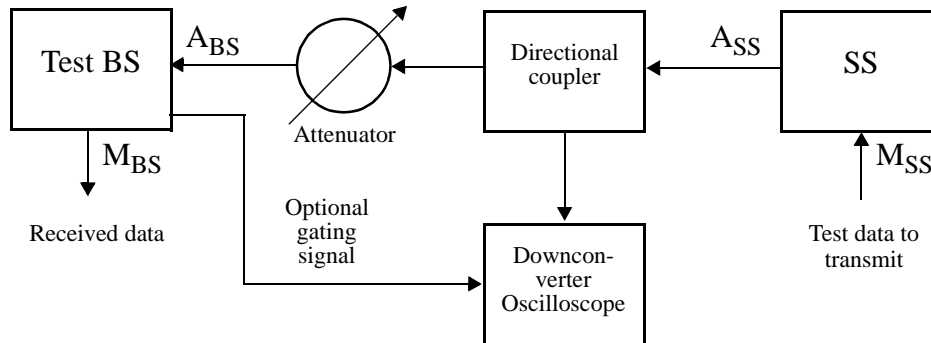

Figure 24—Test setup for Tx Burst timing

Instruments needed:

- Directional coupler
- Attenuator
- Downconveter
- Oscilloscope

9.1.22.2 Test procedure

The losses for the coupler and the connecting waveguides are measured and the attenuator is calibrated. When measuring the power the losses, the effect of the coupler and the duty cycle shall be taken into account.

A connection is setup between the Test BS and the SS. Data is transmitted in the uplink with QPSK modulation.

The Test BS defines the burst at different positions with 0.25 symbol time resolution by using unsolicited RNG-RSP messages.

The actual position of the burst is compared with the gating signal provided by the Test BS. The difference shall be less than 0.125 symbol time.

9.1.23 Carrier frequency

9.1.23.1 Test setup

Figure 25 shows the test setup for testing the carrier frequency.

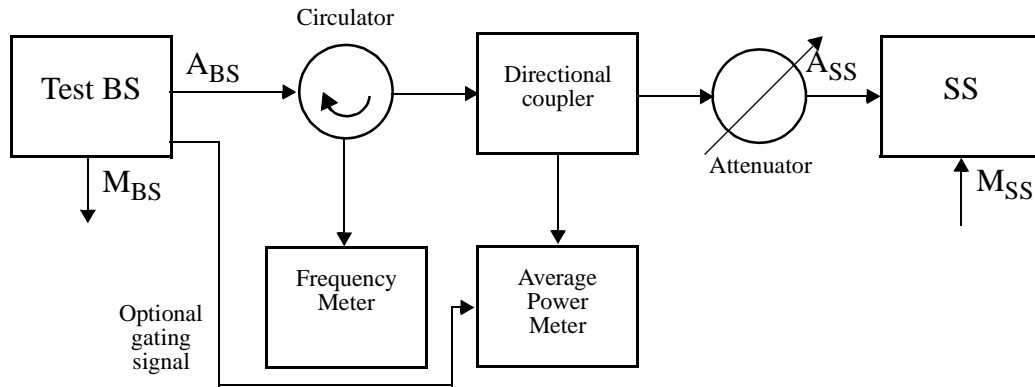

Figure 25—Test setup for Carrier frequency

Instruments needed:

- Directional coupler
- Average power meter
- Circulator
- Attenuator
- Frequency meter

9.1.23.2 Test procedure

The losses for the coupler and the connecting waveguides are measured and the attenuator is calibrated. When measuring the power the losses, the effect of the coupler and the duty cycle shall be taken into account.

The SS is set in the CW test mode. The Test BS transmits a downlink signal containing only the control portion. The signal is adjusted until the received power is $-98 + 10\log(B)$ dBm, where B is the symbol rate in MBaud, in order to correspond to a worst case signal.

The Test BS generates frequencies which are multiples of 250 KHz in frequency range declared by the SS manufacturer

The SS is able to lock to the frequencies generated by the Test BS. For TDD the frequencies for the Test BS and SS shall be equal and for FDD they shall be separated by the duplex distance declared by the manufacturer.

9.1.24 Spectral mask

9.1.24.1 Test setup

Figure 26 shows the test setup for testing the spectral mask.

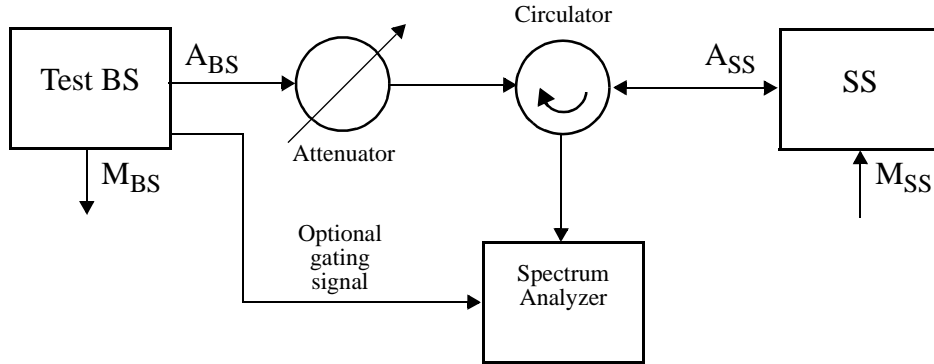

Figure 26—Test setup for Spectral mask

Instruments needed: Circulator
 Attenuator
 Spectrum Analyzer

9.1.24.2 Test procedure

The losses for the coupler and the connecting waveguides are measured and the attenuator is calibrated. When measuring the power the losses, the effect of the coupler and the duty cycle shall be taken into account.

A connection is setup between the Test BS and the SS. The Test BS commands the SS to use the most robust burst profile. Data is transmitted in the uplink.

The spectrum is measured with a spectrum analyzer. The spectrum shall not exceed the mask given by the local regulator.

The settings of the spectrum analyzer shall be according to table 2. B is the channel width in MHz.

Table 2—Spectrum analyzer settings

Paramter	SS
Center frequency	Actual
Span	5 * B MHz
Scan time	Auto
Resolution bandwidth	300 KHz
Video bandwidth	100 KHz

9.1.25 Ramp up / down time

9.1.25.1 Test setup

Figure 27 shows the test setup for testing the Ramp up / down time.

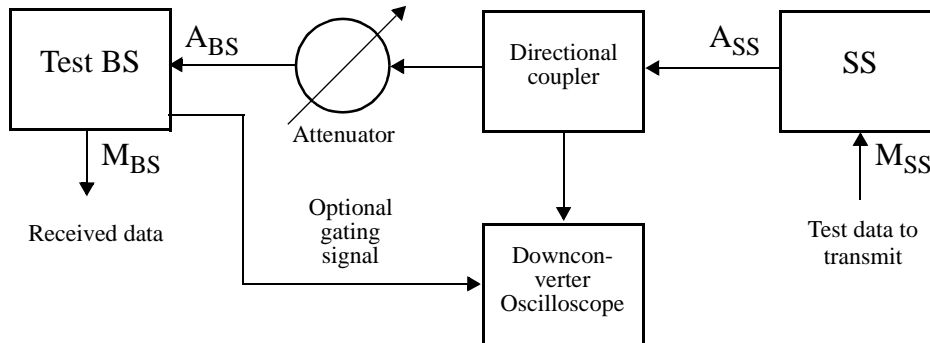

Figure 27—Test setup for Ramp up / down time

Instruments needed:

- Directional coupler
- Attenuator
- Downconerter
- Oscilloscope

9.1.25.2 Test procedure

The losses for the coupler and the connecting waveguides are measured and the attenuator is calibrated. When measuring the power the losses, the effect of the coupler and the duty cycle shall be taken into account.

A connection is setup between the Test BS and the SS. Data is transmitted in the uplink with QPSK modulation.

The ramp up/ ramp down times are measured and shall be ≤ 24 symbols.

9.1.26 Output noise power spectral density when Tx is not transmitting

9.1.26.1 Test setup

Figure 28 shows the test setup for testing the Output noise power spectral density.

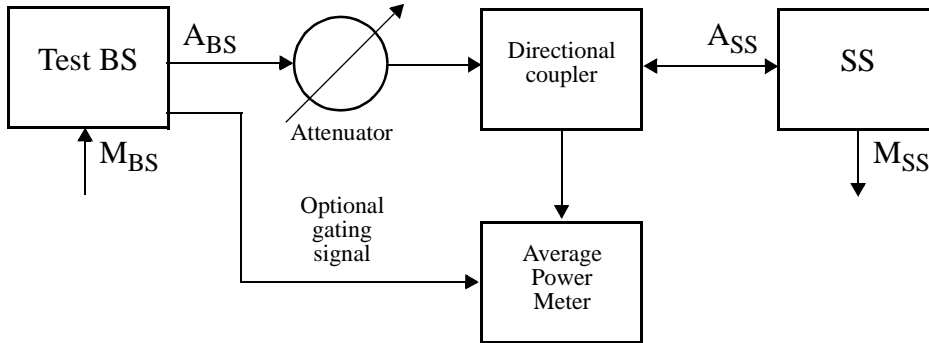

Figure 28—Test setup for Output noise power spectral density

Instruments needed: Directional coupler
 Attenuator
 Average power meter

9.1.26.2 Test procedure

The losses for the coupler and the connecting waveguides are measured and the attenuator is calibrated. When measuring the power the losses, the effect of the coupler and the duty cycle shall be taken into account.

A connection is setup between the Test BS and the SS. The Test BS allocates a small amount of data in each uplink frame. The actual measurement is made during the period when the SS is not transmitting.

The output noise power emitted from the SS when not transmitting shall be ≤ -80 dBm/Mhz

9.1.27 Modulation accuracy

9.1.27.1 Test setup

Figure 28 shows the test setup for testing the modulation accuracy.

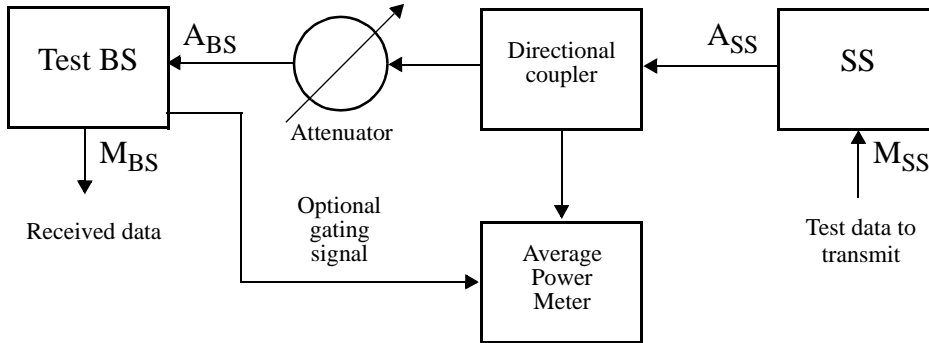

Figure 29—Test setup for Modulation accuracy

Instruments needed: Directional coupler
 Attenuator
 Average power meter

9.1.27.2 Test procedure

The losses for the coupler and the connecting waveguides are measured and the attenuator is calibrated. When measuring the power the losses, the effect of the coupler and the duty cycle shall be taken into account.

The system is setup for a BER test for the Test BS. The sensitivity value P for the Test BS for BER=10⁻³ is measured using a high quality transmitter as the signal source with a known implementation margin K.

The sensitivity value M for the Test BS for BER=10⁻³ is measured using the SS as the signal source. The expression M - P + K shall be less than or equal to the values in column 2 in table 3. The corresponding EVM figures are shown in columns 3 and 4.

Table 3—EVM requirements

	Tx implementation margin	EVM no equalizer	EVM equalizer
QPSK	0.5 dB	12 %	10 %
16-QAM	1.0 dB	6 %	3 %
64-QAM	1.5 dB		1.5 %

9.1.28 BER performance threshold

9.1.28.1 Test setup

Figure 30 shows the test setup for testing the BER performance threshold.

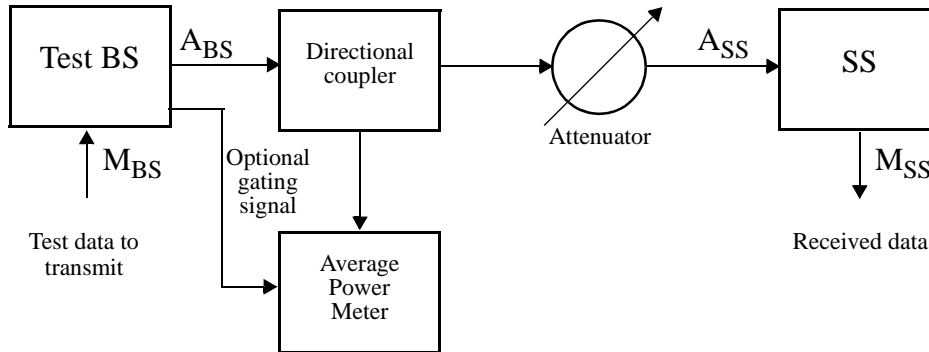

Figure 30—Test setup for BER performance threshold

Instruments needed:

- Directional coupler
- Attenuator
- Average power meter

9.1.28.2 Test procedure

The losses for the coupler and the connecting waveguides are measured and the attenuator is calibrated. When measuring the power the losses, the effect of the coupler and the duty cycle shall be taken into account.

A connection is setup between the Test BS and the SS. The Test BS transmits the bursts with all supported modulation schemes and no FEC. CRC is disabled

The BER is computed from the payload of the data packets accepted by the SS. The attenuator is adjusted until $BER = 10^{-3}$ and then 10^{-6} . The input power is measured and shall be according to table 4. B is the symbol rate in MBaud.

Table 4—BER performance threshold sensitivity values

	BER 10^{-3}	BER 10^{-6}
QPSK	$-94 + 10\log(B)$ dBm	$-90 + 10\log(B)$ dBm
16-QAM	$-87 + 10\log(B)$ dBm	$-83 + 10\log(B)$ dBm
64-QAM	$-79 + 10\log(B)$ dBm	$-74 + 10\log(B)$ dBm

9.1.29 Transition time from Tx to Rx and from Rx to Tx

9.1.29.1 Test setup

Figure 31 shows the test setup for testing the Transition time from Tx to Rx and from Rx to Tx.

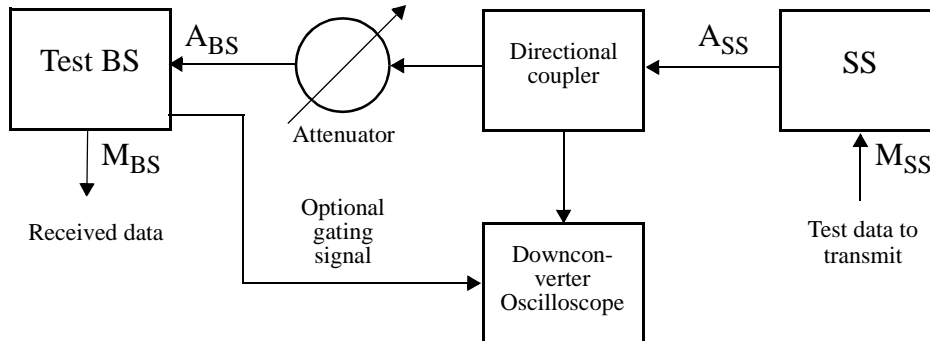

Figure 31—Test setup for Transition time from Tx to Rx and from Rx to Tx

Instruments needed:

- Directional coupler
- Attenuator
- Downconverter
- Oscilloscope

9.1.29.2 Test procedure

The losses for the coupler and the connecting waveguides are measured and the attenuator is calibrated. When measuring the power the losses, the effect of the coupler and the duty cycle shall be taken into account.

A connection is setup between the Test BS and the SS. The attenuator is adjusted for an optimal signal quality. The Test BS provides downlink and uplink maps with a transition time between the end of an uplink burst and the start of a downlink burst of 2 μ s for TDD and 20 μ s for H-FDD and with transition times between the end of a downlink burst and start of an uplink burst of 2 μ s for TDD and 20 μ s for H-FDD. Uplink and downlink data is generated.

The SS successfully transmits uplink data and receives downlink data.

9.1.30 1st adjacent channel interference

9.1.30.1 Test setup

Figure 32 shows the test setup for testing the 1st adjacent channel interference.

1
2
3
4
5
6
7
8
9
10
11
12
13
14
15
16
17
18
19
20
21
22
23
24
25
26
27
28
29

Table 5—1st adjacent channel interference BER 10^{-3}

	1 dB degradation	3 dB degradation
QPSK	-5 dB	-9 dB
16-QAM	+2 dB	-2 dB
64-QAM	+9 dB	+5 dB

Table 6—1st adjacent channel interference BER= 10^{-6}

	1 dB degradation	3 dB degradation
QPSK	-1 dB	-5 dB
16-QAM	+6 dB	+2 dB
64-QAM	+13 dB	+9 dB

Table 7—2nd adjacent channel interference BER 10^{-3}

	1 dB degradation	3 dB degradation
QPSK	-30 dB	-34 dB
16-QAM	-22 dB	-27 dB
64-QAM	-16 dB	-20 dB

Table 8—2nd adjacent channel interference BER= 10^{-6}

	1 dB degradation	3 dB degradation
QPSK	-26 dB	-30 dB
16-QAM	-20 dB	-23 dB
64-QAM	-12 dB	-16 dB

1
2
3
4
5
6
7
8
9
10
11
12
13
14
15
16
17
18
19
20
21
22
23
24
25
26
27
28
29
30
31
32
33
34
35
36
37
38
39
40
41
42
43
44
45
46
47
48
49
50
51
52
53
54
55
56
57
58
59
60
61
62
63
64
65

9.1.32 Tx Power level absolute accuracy

9.1.32.1 Test setup

Figure 34 shows the test setup for testing the Tx Power level absolute accuracy.

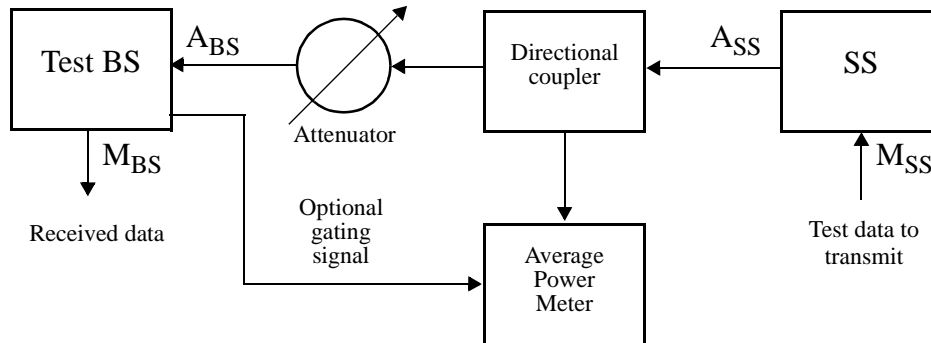

Figure 34—Test setup for Tx Power level absolute accuracy

Instruments needed:

- Directional coupler
- Attenuator
- Average power meter

9.1.32.2 Test procedure

The losses for the coupler and the connecting waveguides are measured and the attenuator is calibrated. When measuring the power the losses, the effect of the coupler and the duty cycle shall be taken into account.

A connection is setup between the Test BS and the SS. The Test BS commands the SS to use the most robust burst profile at the bottom, medium and top values of the transmit power range. Data is transmitted in the uplink. The transmit power is measured.

The Test BS commands the SS to adjust its transmit power level to an absolute level in the current power range. The Test BS shall receive the data correctly.

The accuracy of the power level shall be +/- 6 dB.

9.2 Tests for the Base Station

9.2.1 RS outer code t = 10 / BCC - frame control

9.2.1.1 Test setup

Figure 35 shows the test setup for testing the RS outer code t = 10 / BCC - frame control.



Figure 35—Test setup for RS outer code t = 10 / BCC - frame control

Instruments needed: Directional coupler
 Attenuator
 Average power meter

9.2.1.2 Test procedure

The losses for the coupler and the connecting waveguides are measured and the attenuator is calibrated. When measuring the power the losses, the effect of the coupler and the duty cycle shall be taken into account.

The BS is operable. No connections are set up. The Test SS tries to register.

The Test SS is able to register to the BS.

9.2.2 RS outer code other bursts

9.2.2.1 Test setup

Figure 36 shows the test setup for testing the RS outer code other bursts.

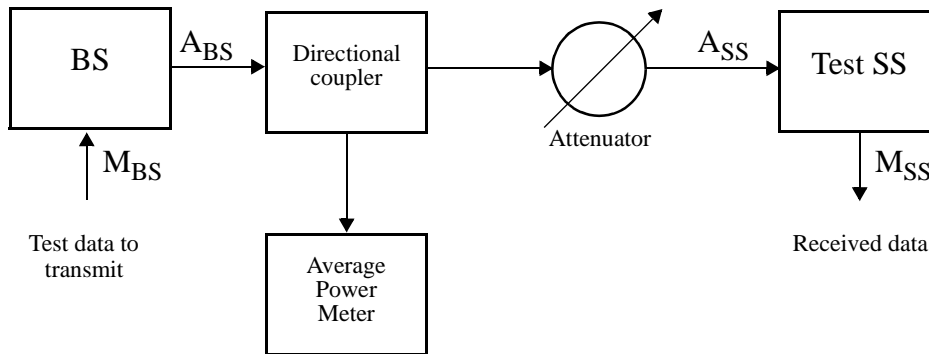

Figure 36—Test setup for RS outer code other bursts

Instruments needed:

- Directional coupler
- Attenuator
- Average power meter

9.2.2.2 Test procedure

The losses for the coupler and the connecting waveguides are measured and the attenuator is calibrated. When measuring the power the losses, the effect of the coupler and the duty cycle shall be taken into account.

A connection is setup between the BS and the Test SS. The Test SS requests the BS to use bursts profiles with RS parameter $t = 0, 4, 8$ and 12 . Data is transmitted in the downlink.

The SS shall receive the data correctly.

9.2.3 Fixed codeword operation

9.2.3.1 Test setup

Figure 37 shows the test setup for testing the RS fixed codeword operation.

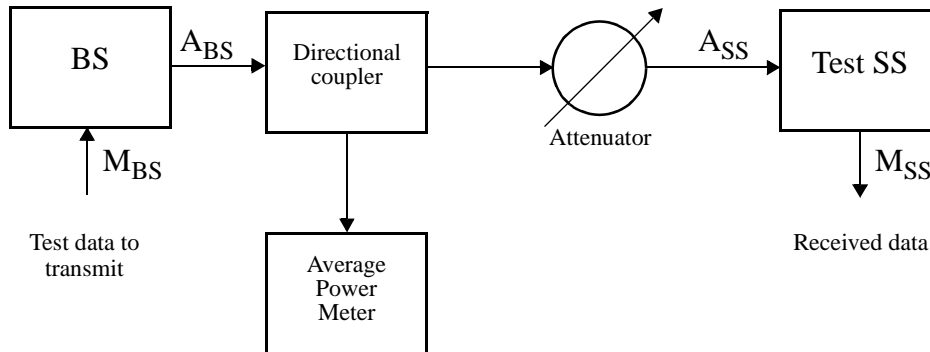

Figure 37—Test setup for Fixed codeword operation

Instruments needed:

- Directional coupler
- Attenuator
- Average power meter

9.2.3.2 Test procedure

The losses for the coupler and the connecting waveguides are measured and the attenuator is calibrated. When measuring the power the losses, the effect of the coupler and the duty cycle shall be taken into account.

A connection is setup between the BS and the Test SS. The Test SS requests the BS to use burst profiles with fixed codeword operation.

Data is transmitted in the downlink.

The SS receives the data correctly.

9.2.4 Shortened last codeword operation

9.2.4.1 Test setup

Figure 38 shows the test setup for testing the RS shortened codeword operation.

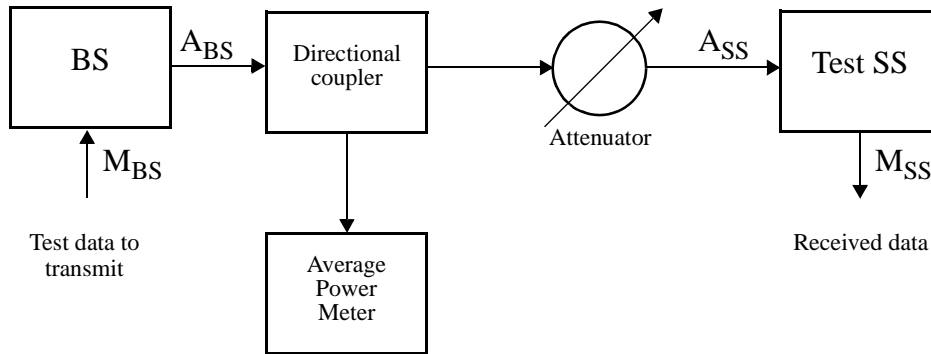

Figure 38—Test setup for Shortened codeword operation

Instruments needed: Directional coupler
 Attenuator
 Average power meter

9.2.4.2 Test procedure

The losses for the coupler and the connecting waveguides are measured and the attenuator is calibrated. When measuring the power the losses, the effect of the coupler and the duty cycle shall be taken into account.

A connection is setup between the BS and the Test SS. The Test SS requests the BS to use burst profiles with shortened codeword operation.

Data is transmitted in the downlink.

The SS receives the data correctly.

9.2.5 Burst preamble

9.2.5.1 Test setup

Figure 39 shows the test setup for testing the burst preamble.

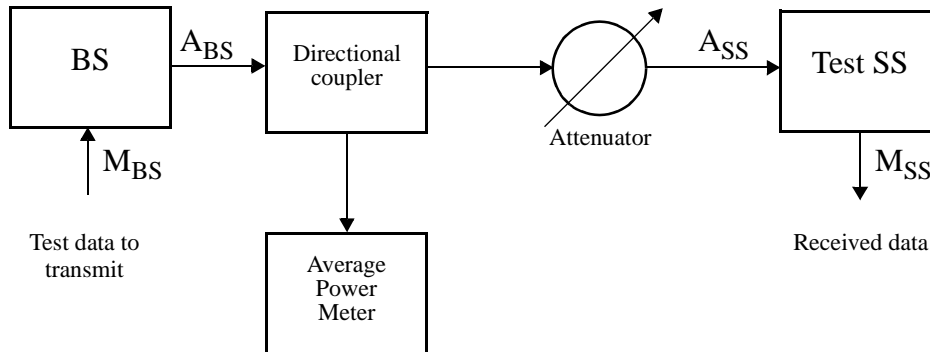

Figure 39—Test setup for burst preamble

Instruments needed:

- Directional coupler
- Attenuator
- Average power meter

9.2.5.2 Test procedure

The losses for the coupler and the connecting waveguides are measured and the attenuator is calibrated. When measuring the power the losses, the effect of the coupler and the duty cycle shall be taken into account.

A connection is setup between the Test BS and the half-duplex Test SS.

Data is transmitted in the TDMA portion of the downlink

The SS receives the data correctly.

9.2.6 Modulation

9.2.6.1 Test setup

Figure 40 shows the test setup for testing the modulation.

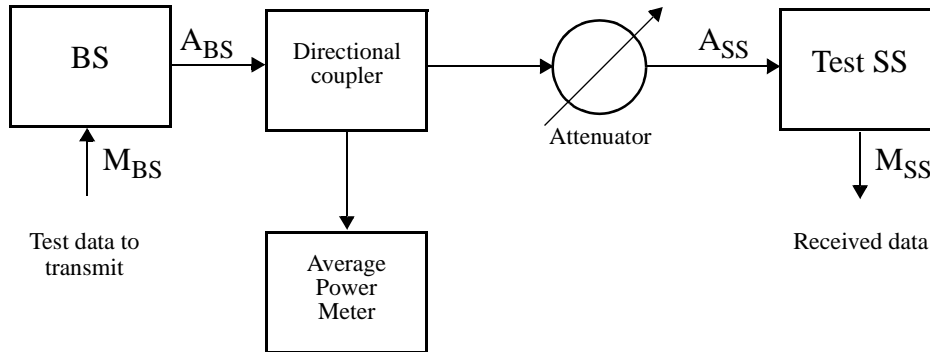

Figure 40—Test setup for modulation

Instruments needed:

- Directional coupler
- Attenuator
- Average power meter

9.2.6.2 Test procedure

The losses for the coupler and the connecting waveguides are measured and the attenuator is calibrated. When measuring the power the losses, the effect of the coupler and the duty cycle shall be taken into account.

A connection is setup between the BS and the Test SS. The Test SS requests the BS to use burst profiles with different modulation schemes supported by the BS.

The downlink frame is filled with bursts of test data. The received power is adjusted until the S/N is approximately 10 dB above the actual threshold to ensure the quality of the signal.

The SS receives the data correctly.

9.2.7 RS outer code - Information Block Length

9.2.7.1 Test setup

Figure 41 shows the test setup for testing the RS outer code - Information Block Length.

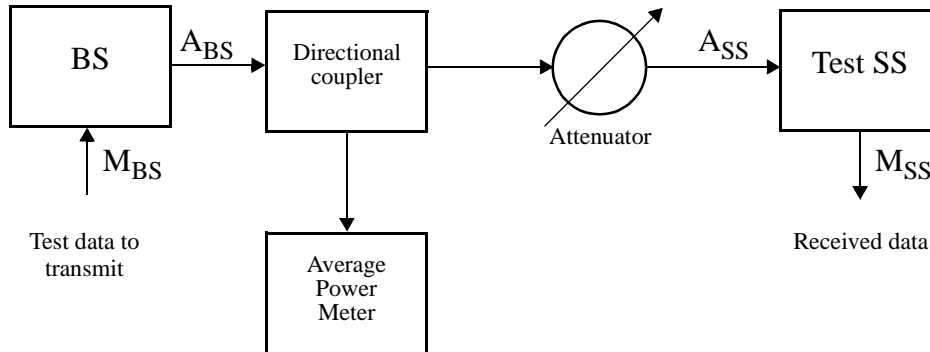

Figure 41—Test setup for RS outer code - Information Block Length

Instruments needed:

- Directional coupler
- Attenuator
- Average power meter

9.2.7.2 Test procedure

The losses for the coupler and the connecting waveguides are measured and the attenuator is calibrated. When measuring the power the losses, the effect of the coupler and the duty cycle shall be taken into account.

A connection is setup between the BS and the Test SS. QPSK modulation, no BCC coding, RS coding with information block length = 6, 128, 239 and $t = 8$ are used.

The downlink frame is filled with bursts of test data. The received power is adjusted until the S/N is approximately 10 dB above the actual threshold to ensure the quality of the signal.

The SS shall receive the data correctly.

9.2.8 Randomization with programmable seed

9.2.8.1 Test setup

Figure 42 shows the test setup for randomization with programmable seed.

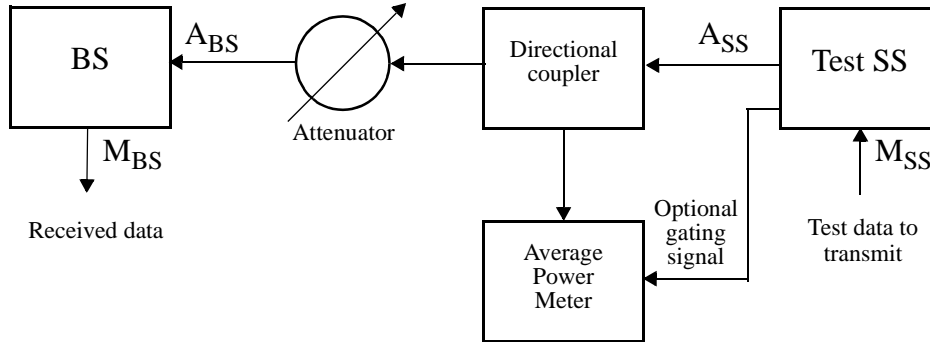

Figure 42—Test setup for randomization with programmable seed

Instruments needed:

- Directional coupler
- Attenuator
- Average power meter

9.2.8.2 Test procedure

The losses for the coupler and the connecting waveguides are measured and the attenuator is calibrated. When measuring the power the losses, the effect of the coupler and the duty cycle shall be taken into account.

A connection is setup between the BS and the Test SS. Various UL burst profiles are defined differeng only in their seed values. The test NMS requests the BS to use burst profiles with different seed values for the randomization.

Data is transmitted in the uplink.

The BS receives the data correctly.

9.2.9 RS outer code - Initial ranging

9.2.9.1 Test setup

Figure 43 shows the test setup for testing the RS outer code - Initial ranging.

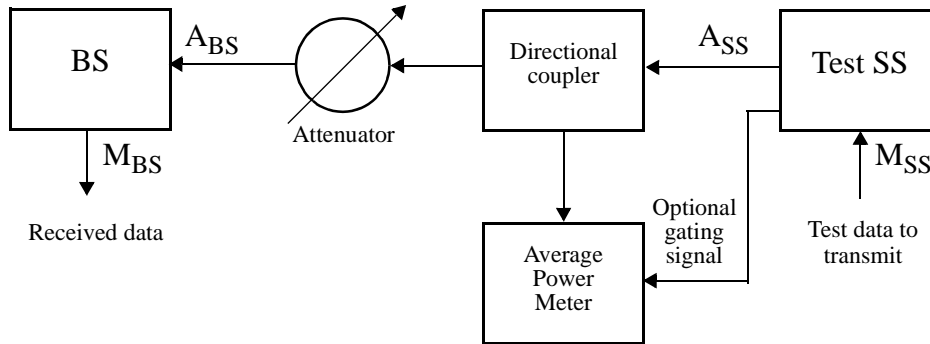

Figure 43—Test setup for RS outer code - Initial ranging

Instruments needed:

- Directional coupler
- Attenuator
- Average power meter

9.2.9.2 Test procedure

The losses for the coupler and the connecting waveguides are measured and the attenuator is calibrated. When measuring the power the losses, the effect of the coupler and the duty cycle shall be taken into account.

A connection is setup between the BS and the Test SS.

The test NMS requests the BS to use burst profiles with RS parameter $t = 10$.

Data is transmitted in the uplink. The Test BS receives the data correctly.

9.2.10 RS outer code other bursts

9.2.10.1 Test setup

Figure 44 shows the test setup for testing the RS outer code other bursts.

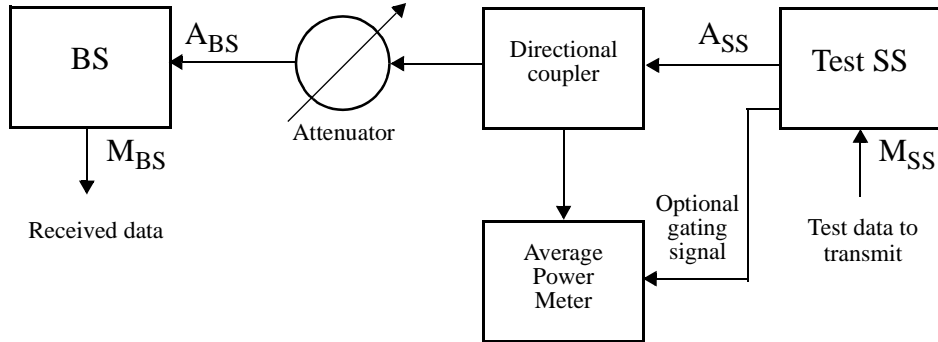

Figure 44—Test setup for RS outer code other bursts

Instruments needed:

- Directional coupler
- Attenuator
- Average power meter

9.2.10.2 Test procedure

The losses for the coupler and the connecting waveguides are measured and the attenuator is calibrated. When measuring the power the losses, the effect of the coupler and the duty cycle shall be taken into account.

A connection is setup between the BS and the Test SS. The test NMS requests the BS to use burst profiles with the RS parameter $t = 0, 4, 8$ or 12 , and information bytes 128 are used.

The uplink frame is filled with bursts of test data. The data received at the BS is checked for correctness.

The Test SS inserts alternatively 0, 4, 8 or 12 erroneous bytes in the codeword corresponding to $t = 0, 4, 8$ and 12. The BS shall receive the data correctly.

The Test SS inserts alternatively 1, 5, 9 or 13 erroneous bytes in the codeword corresponding to $t = 0, 4, 8$ and 12. The BS shall not be able to receive the data correctly.

9.2.11 Fixed codeword operation

9.2.11.1 Test setup

Figure 45 shows the test setup for testing the RS fixed codeword operation.

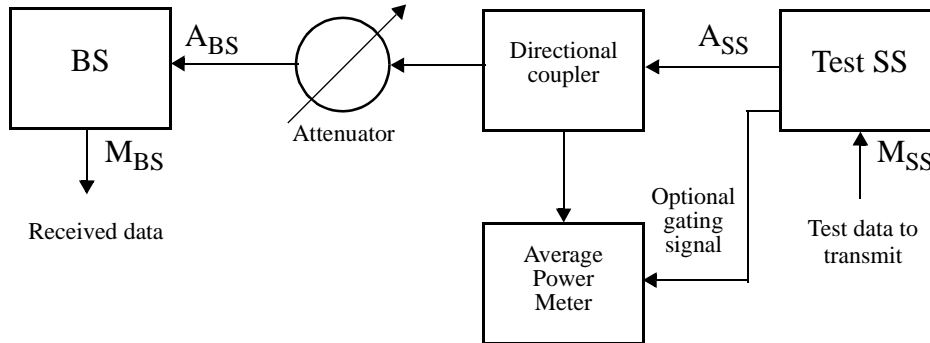

Figure 45—Test setup for Fixed codeword operation

Instruments needed:

- Directional coupler
- Attenuator
- Average power meter

9.2.11.2 Test procedure

The losses for the coupler and the connecting waveguides are measured and the attenuator is calibrated. When measuring the power the losses, the effect of the coupler and the duty cycle shall be taken into account.

A connection is setup between the BS and the Test SS. The test NMS requests the BS to use burst profiles with Reed-Solomon Fixed codeword option, QPSK modulation, no BCC coding, RS coding with $t = 8$ and information bytes = 128.

The uplink frame is filled with bursts of test data. The number of bytes in the uplink frame must be not be a multiple of 128.

The BS receives the data correctly.

9.2.12 Shortened last codeword operation

9.2.12.1 Test setup

Figure 46 shows the test setup for testing the RS shortened codeword operation.

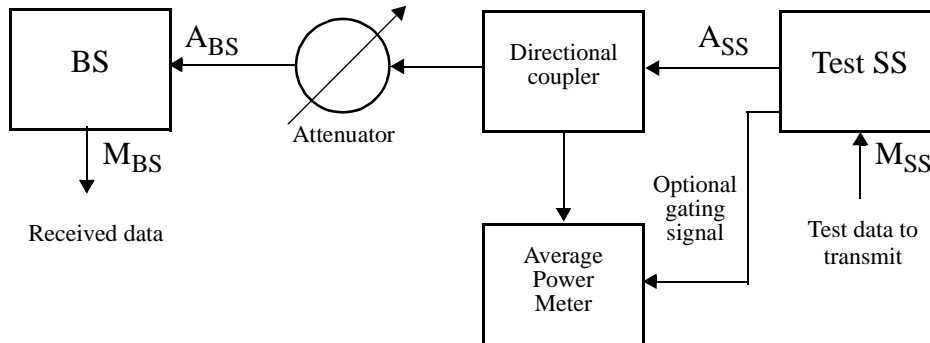

Figure 46—Test setup for Shortened codeword operation

Instruments needed:

- Directional coupler
- Attenuator
- Average power meter

9.2.12.2 Test procedure

The losses for the coupler and the connecting waveguides are measured and the attenuator is calibrated. When measuring the power the losses, the effect of the coupler and the duty cycle shall be taken into account.

A connection is setup between the BS and the Test SS. The test NMS requests the BS to use burst profiles with Reed-Solomon Shortened codeword option, QPSK modulation, no BCC coding, RS coding with $t = 8$ and information bytes = 128.

The uplink frame is filled with bursts of test data. The number of bytes in the uplink frame must be not be a multiple of 128.

The BS receives the data correctly.

9.2.13 BCC inner code

9.2.13.1 Test setup

Figure 47 shows the test setup for testing the BCC innercode operation.

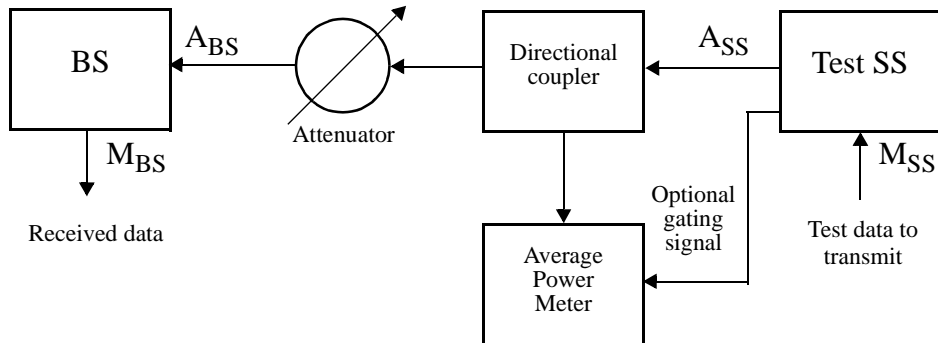

Figure 47—Test setup for BCC inner code operation

Instruments needed:

- Directional coupler
- Attenuator
- Average power meter

9.2.13.2 Test procedure

The losses for the coupler and the connecting waveguides are measured and the attenuator is calibrated. When measuring the power the losses, the effect of the coupler and the duty cycle shall be taken into account.

A connection is setup between the BS and the Test SS. The test NMS requests the BS to use a burst profile with BCC inner code.

Data is transmitted in the uplink.

The BS receives the data correctly.

9.2.14 Burst preamble

9.2.14.1 Test setup

Figure 48 shows the test setup for testing the burst preamble.

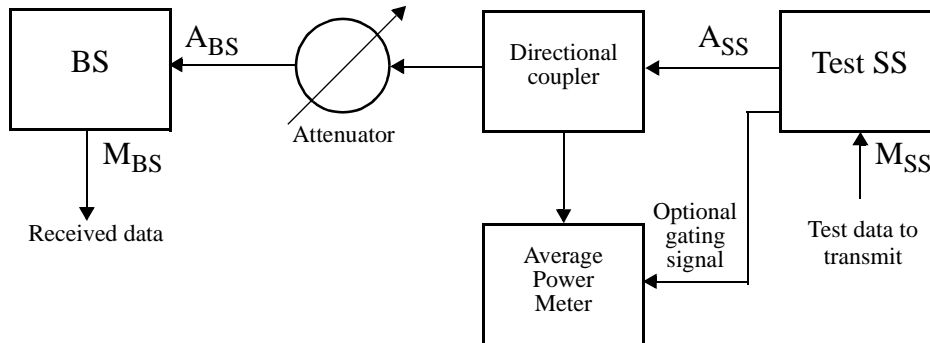

Figure 48—Test setup for burst preamble

Instruments needed:

- Directional coupler
- Attenuator
- Average power meter

9.2.14.2 Test procedure

The losses for the coupler and the connecting waveguides are measured and the attenuator is calibrated. When measuring the power the losses, the effect of the coupler and the duty cycle shall be taken into account.

A connection is setup between the BS and the Test SS. The test NMS requests the BS to use burst profiles with different preamble lengths.

Data is transmitted in the uplink.

The BS receives the data correctly.

9.2.15 Modulation

9.2.15.1 Test setup

Figure 49 shows the test setup for testing the modulation schemes.

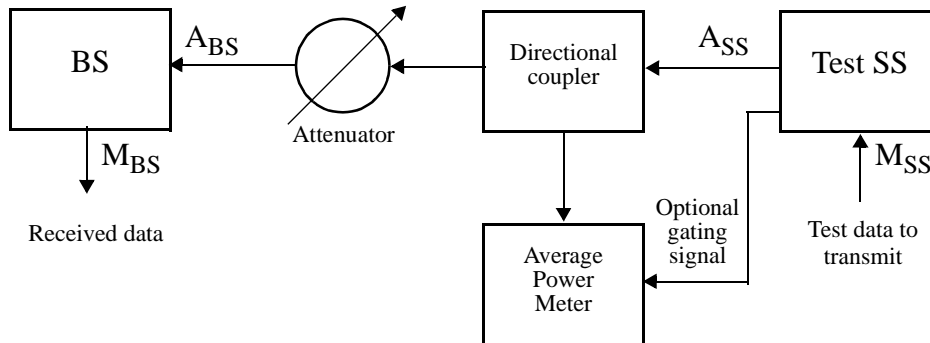

Figure 49—Test setup for the modulation schemes

Instruments needed:

- Directional coupler
- Attenuator
- Average power meter

9.2.15.2 Test procedure

The losses for the coupler and the connecting waveguides are measured and the attenuator is calibrated. When measuring the power the losses, the effect of the coupler and the duty cycle shall be taken into account.

A connection is setup between the BS and the Test SS. The test NMS requests the BS to use burst profiles with the different modulation schemes supported by the SS.

Data is transmitted in the uplink.

The BS receives the data correctly.

9.2.16 RS outer code - Information Block Length

9.2.16.1 Test setup

Figure 50 shows the test setup for testing the RS outer code - Information Block Length.

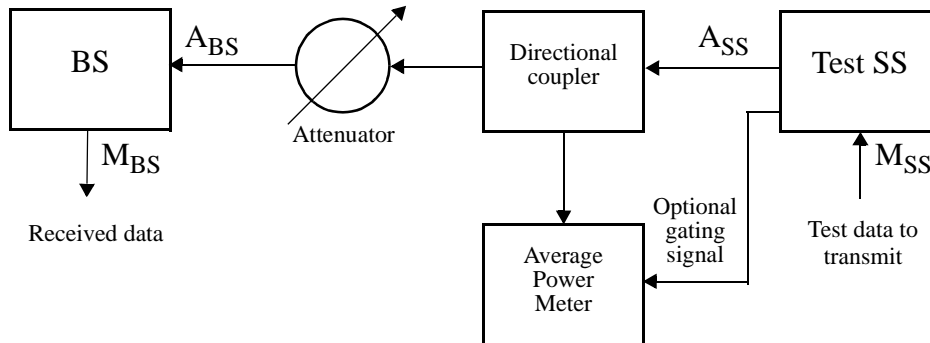

Figure 50—Test setup for RS outer code - Information Block Length

Instruments needed:

- Directional coupler
- Attenuator
- Average power meter

9.2.16.2 Test procedure

The losses for the coupler and the connecting waveguides are measured and the attenuator is calibrated. When measuring the power the losses, the effect of the coupler and the duty cycle shall be taken into account.

A connection is setup between the BS and the Test SS. The test NMS requests the BS to use burst profiles with the the RS parameter Information block length = 6, 128 and 239. RS parameter $t = 8$.

Data is transmitted in the uplink.

The BS receives the data correctly.

9.2.17 Channel allocation

9.2.17.1 Test setup

Figure 51 shows the test setup for testing the channel allocation.

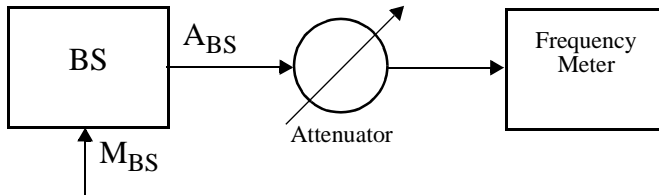

Figure 51—Test setup for Channel allocation

Instruments needed: Attenuator
 Frequency meter

9.2.17.2 Test procedure

The BS is set in the CW test mode. The attenuator is adjusted for an optimal reception level.

The BS is requested to generate frequencies which are multiples of 250 kHz in the frequency range declared by the manufacturer

The BS is able to generate frequencies which are multiples of 250 kHz.

9.2.18 Symbol timing accuracy

9.2.18.1 Test setup

Figure 52 shows the test setup for testing the symbol timing accuracy.

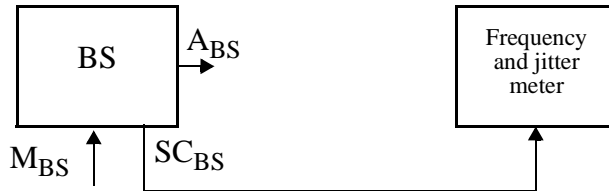

Figure 52—Test setup for symbol timing accuracy

Instruments needed: Frequency meter
 Jitter meter

9.2.18.2 Test procedure

The BS is operable and the symbol clock frequency and jitter are measured.

The symbol clock accuracy shall be within +/-15 ppm of its nominal value. The peak-to-peak jitter of the symbol clock during a 2 sec measurement period shall be less than 2 %.

9.2.19 Carrier frequency

9.2.19.1 Test setup

Figure 53 shows the test setup for testing the carrier frequency.

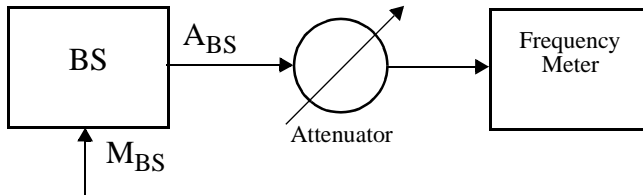

Figure 53—Test setup for Carrier frequency

Instruments needed: Attenuator
 Frequency meter

9.2.19.2 Test procedure

The BS is set in the CW test mode. The attenuator is adjusted for an optimal reception level

The BS is requested to generate frequencies which are multiples of 250 KHz in frequency range declared by the manufacturer

The accuracy shall be better than +/- 10 ppm.

9.2.20 Spectral mask

9.2.20.1 Test setup

Figure 54 shows the test setup for testing the spectral mask.

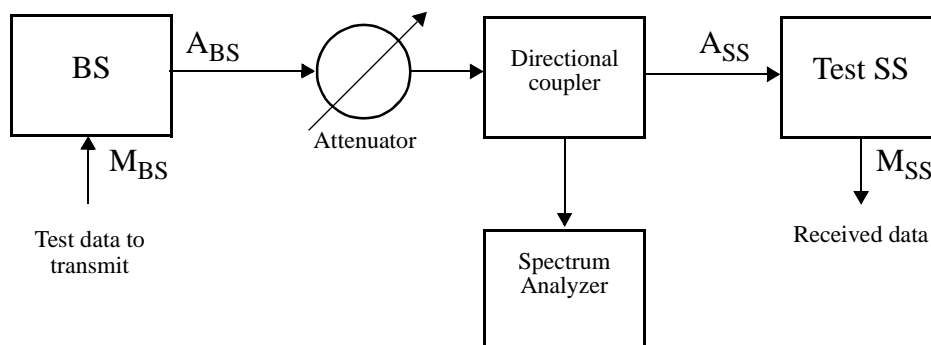

Figure 54—Test setup for Spectral mask

Instruments needed: Attenuator
 Spectrum Analyzer

9.2.20.2 Test procedure

A connection is setup between the BS and the Test SS. The downlink frame is filled with QPSK modulated data.

The spectrum is measured with a spectrum analyzer. The spectrum shall not exceed the mask given by the local regulator.

The settings of the spectrum analyzer shall be according to table 9. B is the channel width in MHz.

Table 9—Spectrum analyzer settings

Paramter	SS
Center frequency	Actual
Span	5 * B MHz
Scan time	Auto
Resolution bandwidth	300 KHz
Video bandwidth	100 KHz

9.2.21 Spurious

9.2.21.1 Test setup

Figure 56 shows the test setup for testing the spurious frequencies.

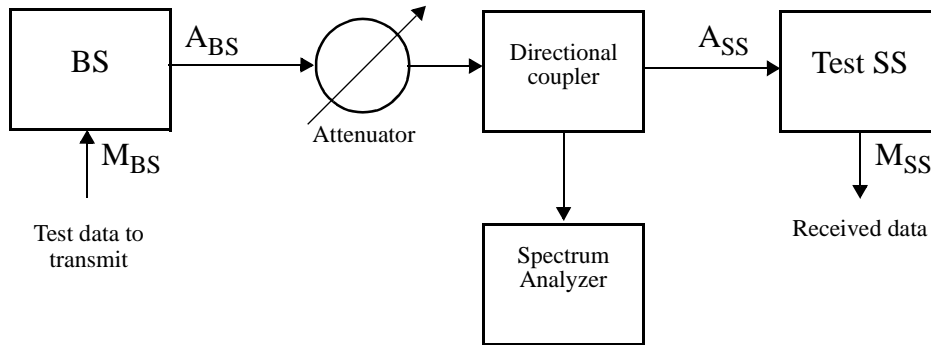

Figure 55—Test setup for Spurious frequencies

Instruments needed: Attenuator
 Spectrum Analyzer

9.2.21.2 Test procedure

A connection is setup between the BS and the Test SS. The downlink frame is filled with QPSK modulated data.

The spectrum is measured with a spectrum analyzer. The spurious frequencies shall not exceed the values given by the local regulator.

The settings of the spectrum analyzer shall be according to table 10. B is the channel width in MHz.

Table 10—Spectrum analyzer settings

Paramter	SS
Center frequency	Actual
Span	5 * B MHz
Scan time	Auto
Resolution bandwidth	Determined by local regulator
Video bandwidth	Determined by local regulator

9.2.22 Tx RMS Power level

9.2.22.1 Test setup

Figure 56 shows the test setup for testing the Tx RMS Power level

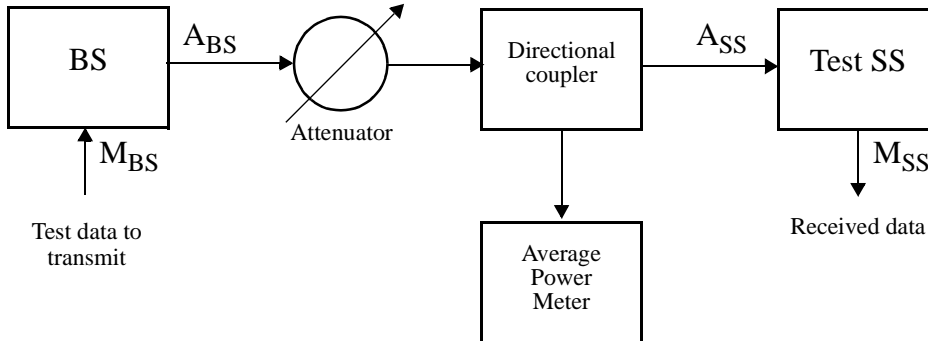

Figure 56—Test setup for Tx RMS power level

Instruments needed:

- Directional coupler
- Attenuator
- Average power meter

9.2.22.2 Test procedure

The losses for the coupler and the connecting waveguides are measured and the attenuator is calibrated. When measuring the power the losses, the effect of the coupler and the duty cycle shall be taken into account.

A connection is setup between the BS and the Test SS. The Test SS requests the BS to use the most robust burst profile. The downlink is filled with data.

The power is measured.

The power shall be = declared value +/- 2 dB.

9.2.23 Ramp up / down time

9.2.23.1 Test setup

Figure 57 shows the test setup for testing the Ramp up / down time.

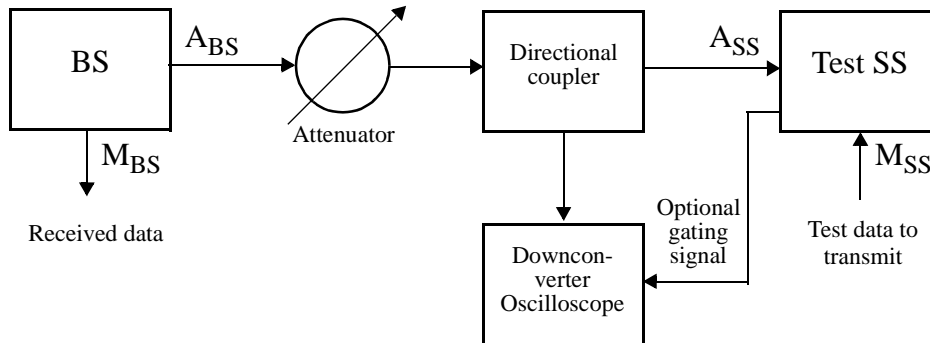

Figure 57—Test setup for Ramp up / down time

Instruments needed:

- Directional coupler
- Attenuator
- Average power meter

9.2.23.2 Test procedure

The losses for the coupler and the connecting waveguides are measured and the attenuator is calibrated. When measuring the power the losses, the effect of the coupler and the duty cycle shall be taken into account.

A connection is setup between the BS and the Test SS. Multiple bursts are transmitted in the downlink with QPSK modulation.

The ramp and ramp down time for the bursts shall be ≤ 24 symbols.

9.2.24 Modulation accuracy

9.2.24.1 Test setup

Figure 58 shows the test setup for testing the modulation accuracy.

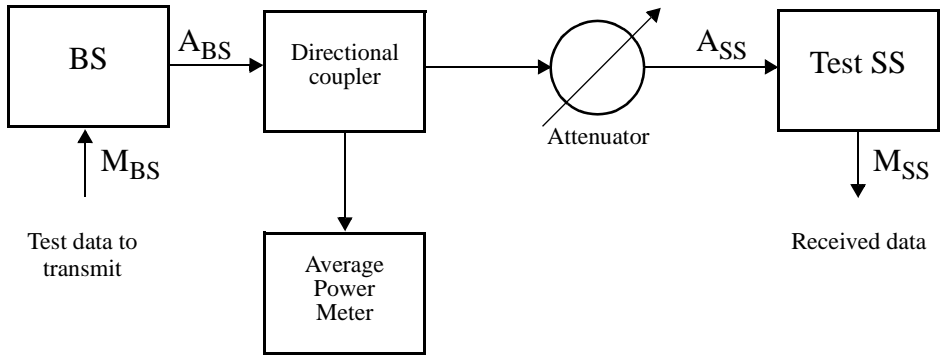

Figure 58—Test setup for Modulation accuracy

Instruments needed: Directional coupler
 Attenuator
 Average power meter

9.2.24.2 Test procedure

The losses for the coupler and the connecting waveguides are measured and the attenuator is calibrated. When measuring the power the losses, the effect of the coupler and the duty cycle shall be taken into account.

The sensitivity value P for the Test SS for BER=10⁻³ is measured using a high quality transmitter as the signal source.

The sensitivity value M for the Test SS for BER=10⁻³ is measured using the BS as the signal source. The difference M - P shall be less than or equal to the values in column 2 in table 11

Table 11—EVM requirements

	Tx implementation margin	EVM no equalizer	EVM equalizer
QPSK	0.5 dB	12 %	10 %
16-QAM	1.0 dB	6 %	3 %
64-QAM	1.5 dB		1.5 %

9.2.25 Rx Dynamic range

9.2.25.1 Test setup

Figure 59 shows the test setup for testing the Rx Dynamic Range

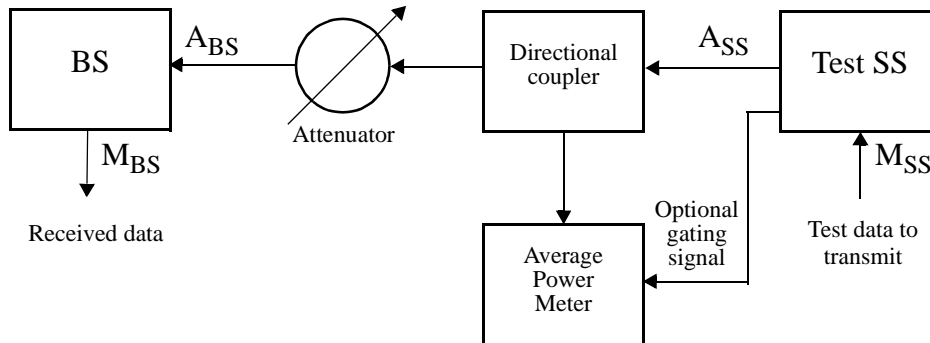

Figure 59—Test setup for Rx Dynamic Range

Instruments needed:

- Directional coupler
- Attenuator
- Average power meter

9.2.25.2 Test procedure

The losses for the coupler and the connecting waveguides are measured and the attenuator is calibrated. When measuring the power the losses, the effect of the coupler and the duty cycle shall be taken into account.

A connection is setup between the BS and the Test SS. The test NMS requests the BS to use the most robust burst profile. Data is transmitted in the uplink.

The attenuator is adjusted until the minimum operable value is reached. The power of the received signal is measured and recorded. The attenuator is then increased until the the maximum operable value is reached. The power is measured and recorded.

The difference between the two power values is the Rx dynamic range and shall be ≥ 27 dB.

9.2.26 BER performance threshold

9.2.26.1 Test setup

Figure 60 shows the test setup for testing the BER performance threshold.

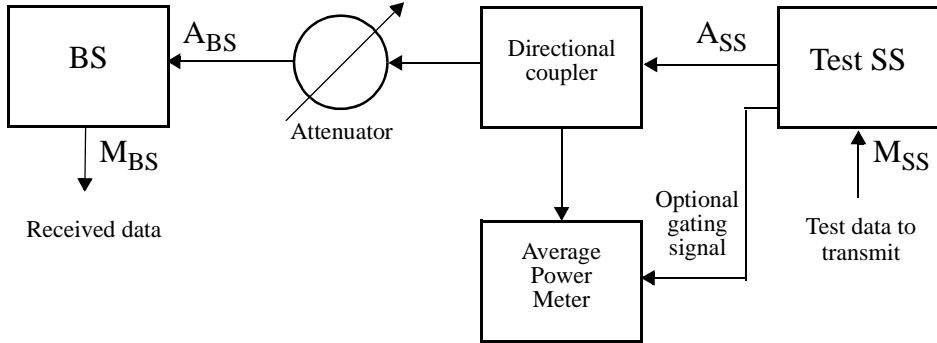

Figure 60—Test setup for BER performance threshold

Instruments needed: Directional coupler
 Attenuator
 Average power meter

9.2.26.2 Test procedure

The losses for the coupler and the connecting waveguides are measured and the attenuator is calibrated. When measuring the power the losses, the effect of the coupler and the duty cycle shall be taken into account.

A connection is setup between the BS and the Test SS. The Test SS transmits the bursts with all supported modulation schemes and no FEC. CRC is disabled

The BER is computed from the payload of the data packets accepted by the BS. The attenuator is adjusted until $BER = 10^{-3}$ and then 10^{-6} . The input power is measured and shall be according to table 12. B is the symbol rate in MBaud.

Table 12—BER performance threshold sensitivity values

	BER 10^{-3}	BER 10^{-6}
QPSK	$-94 + 10\log(B)$ dBm	$-90 + 10\log(B)$ dBm
16-QAM	$-87 + 10\log(B)$ dBm	$-83 + 10\log(B)$ dBm
64-QAM	$-79 + 10\log(B)$ dBm	$-74 + 10\log(B)$ dBm

9.2.27 1st adjacent channel interference

9.2.27.1 Test setup

Figure 61 shows the test setup for testing the 1st adjacent channel interference.

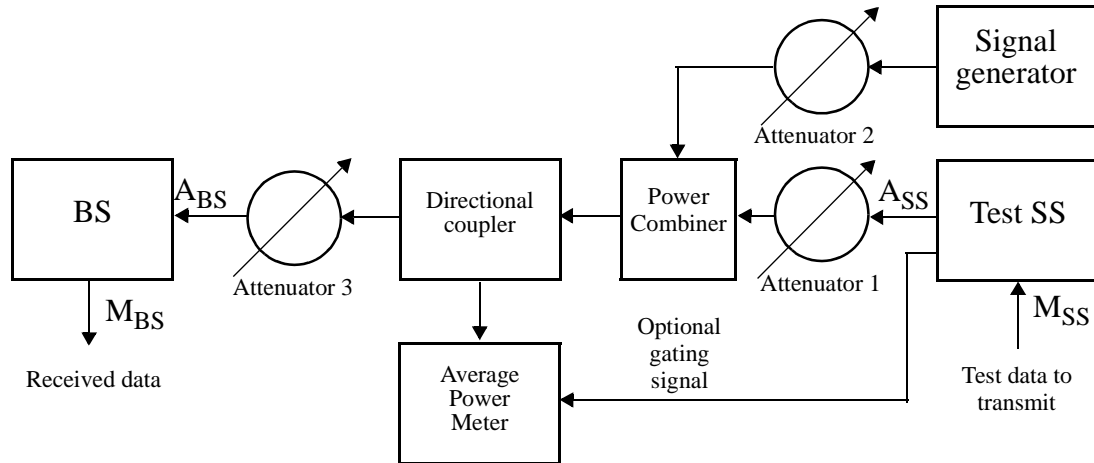

Figure 61—Test setup for 1st adjacent channel interference

Instruments needed:

- Directional coupler
- Attenuators
- Average power meter
- Power combiner
- Signal generator

9.2.27.2 Test procedure

The losses for the coupler and the connecting waveguides are measured and the attenuators are calibrated. When measuring the power the losses, the effect of the coupler and the duty cycle shall be taken into account. Attenuators 1 and 2 are used to adjust the ratio between the useful and interfering signals. Attenuator 3 is used for adjusting the absolute signal level at the receiver and can be held at a constant value of 10 dB. The signal generator transmits a similar signal as the useful signal on the first adjacent channel.

A connection is setup between the BS and the Test SS. Attenuator 2 is set to its maximum value and the signal generator is switched off. The uplink frame is filled with QPSK modulated data and attenuator 1 is adjusted for $BER = 10^{-3}$ (10^{-6}). The signal power is increased by 3 (1) dB and the power is measured.

The signal generator is switched on and attenuator 2 is decreased until $BER = 10^{-3}$ (10^{-6}) is achieved. The Test BS is turned off and the power of the interfering signal is measured.

The procedure is repeated for the other modulation schemes, 1 dB degradation and $BER = 10^{-6}$. The C/I values shall be according to tables 13 and 14.

1
2
3
4
5
6
7
8
9
10
11
12
13
14
15
16
17
18
19
20
21
22
23
24
25
26
27
28
29
30
31
32
33
34
35
36
37
38
39
40
41
42
43
44
45
46
47
48
49
50
51
52
53
54
55
56
57
58
59
60
61
62
63
64
65

Table 13—1st adjacent channel interference BER 10^{-3}

	1 dB degradation	3 dB degradation
QPSK	-5 dB	-9 dB
16-QAM	+2 dB	-2 dB
64-QAM	+9 dB	+5 dB

Table 14—1st adjacent channel interference BER= 10^{-6}

	1 dB degradation	3 dB degradation
QPSK	-1 dB	-5 dB
16-QAM	+6 dB	+2 dB
64-QAM	+13 dB	+9 dB

9.2.28 2nd adjacent channel interference

9.2.28.1 Test setup

Figure 62 shows the test setup for testing the 2nd adjacent channel interference.

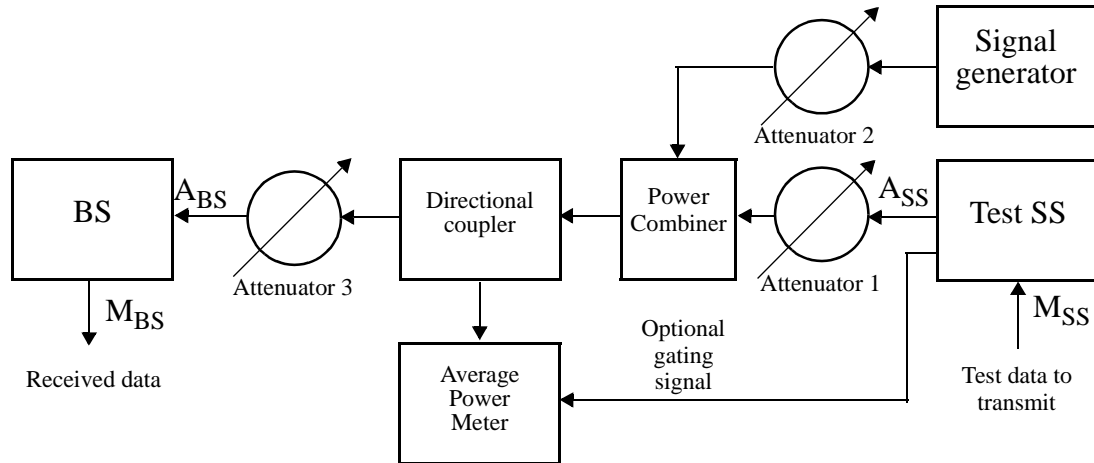

Figure 62—Test setup for 2nd adjacent channel interference

Instruments needed:

- Directional coupler
- Attenuators
- Average power meter
- Power combiner
- Signal generator

9.2.28.2 Test procedure

The losses for the coupler and the connecting waveguides are measured and the attenuators are calibrated. When measuring the power the losses, the effect of the coupler and the duty cycle shall be taken into account. Attenuators 1 and 2 are used to adjust the ratio between the useful and interfering signals. Attenuator 3 is used for adjusting the absolute signal level at the receiver and can be held at a constant value of 10 dB. The signal generator transmits a similar signal as the useful signal on the second adjacent channel.

A connection is setup between the BS and the Test SS. Attenuator 2 is set to its maximum value and the signal generator is switched off. The uplink frame is filled with QPSK modulated data and attenuator 1 is adjusted for $\text{BER} = 10^{-3}$ (10^{-6}). The signal power is increased by 3 (1) dB and the power is measured.

The signal generator is switched on and attenuator 2 is decreased until $\text{BER} = 10^{-3}$ (10^{-6}) is achieved. The Test BS is turned off and the power of the interfering signal is measured.

The procedure is repeated for the other modulation schemes, 1 dB degradation and $\text{BER} = 10^{-6}$. The C/I values shall be according to tables 15 and 16.

Table 15—2nd adjacent channel interference BER 10^{-3}

	1 dB degradation	3 dB degradation
QPSK	-30 dB	-34 dB
16-QAM	-22 dB	-27 dB
64-QAM	-16 dB	-20 dB

Table 16—2nd adjacent channel interference BER= 10^{-6}

	1 dB degradation	3 dB degradation
QPSK	-26 dB	-30 dB
16-QAM	-20 dB	-23 dB
64-QAM	-12 dB	-16 dB

Annex A

A.1 Recommendations for the test laboratories

A.1.1 Antenna input connectors

When flanges are provided at the input port of the antenna they should be in accordance with IEC 60154-2. Table 17 list some IEC and EIA connector types for different frequency bands.

Table 17—Recommended antenna wave guide connectors

EIA	IEC	frequency GHz
WR75	R120	10.0 - 15.0
WR62	R140	12.4 - 18.0
WR51	R180	15.0 - 22.0
WR42	R220	18.0 - 26.5
WR34	R260	22.0 - 33.0
WR28	R320	26.5 - 40.0
WR22	R400	33.0 - 50.0
WR19	R500	40.0 - 60.0

A.1.2 Test equipment

The following equipment is needed for the tests and shall be provided by the test laboratory:

Terminal for system configuration (parameter setting) and control;

RF-Adapter

Spectrum Analyzer

Variable RF-Attenuator

Power meter

Oscilloscope

Printer, Plotter

A.2 General test platform

A.3 Carrier frequencies

1
2
3
4
5
6
7
8
9
10
11
12
13
14
15
16
17
18
19
20
21
22
23
24
25
26
27
28
29
30
31
32
33
34
35
36
37
38
39
40
41
42
43
44
45
46
47
48
49
50
51
52
53
54
55
56
57
58
59
60
61
62
63
64
65