

Project	IEEE 802.16 Broadband Wireless Access Working Group < http://ieee802.org/16 >	
Title	Normal MAP Extension for H-ARQ	
Date Submitted	2005-01-26	
Source(s)	Yigal Eliaspur, Yuval Lomnitz, Zivan Ori	yigal.eliapsur@intel.com , yuval.lomnitz@intel.com , zivan.ori@intel.com
	Intel Corp.	geunhwi.lim@samsung.com , yongchang@samsung.com
	Geunhwi Lim, Jiho Jang, Wonil Roh, Yong Chang, Seungju Maeng	
		ran.yaniv@alvarion.com
	Samsung Electronics Co. Ltd.	
	Ran Yaniv Alvarion Ltd.	mhfong@nortelnetworks.com
	Mo Han Fong, Wen Tong Nortel Networks	bcihm@lge.com
	Bin-Chul Ihm LG Electronics, Inc.	mchion@ztesandiego.com
	Mary Chion, Irving Wang ZTE San Diego Inc.	scchang
	Seokheon Cho, Sungcheol Chang, Chulsik Yoon ETRI	ehosh@etri.re.kr
	Kamran Etemad Greg Schumaker Nextel Communications	jhumbe01@sprintspectrum.com
	John J. Humbert IV Sprint	radu@redlinecommunications.com
	Radu Selea, Bogdan Franovici Redline Communications	
Re:	IEEE P802.16e/D5a	
Abstract	The document contains suggestions for extending the Normal MAP for H-ARQ support. Additionally, certain MAC functions are described for H-ARQ support.	

Additionally, certain MAC fixes are described for H-ARQ support.

Purpose	Adoption of proposed changes into P802.16e /D5a-2004
Notice	This document has been prepared to assist IEEE 802.16. It is offered as a basis for discussion and is not binding on the contributing individual(s) or organization(s). The material in this document is subject to change in form and content after further study. The contributor(s) reserve(s) the right to add, amend or withdraw material contained herein.
Release	The contributor grants a free, irrevocable license to the IEEE to incorporate material contained in this contribution, and any modifications thereof, in the creation of an IEEE Standards publication; to copyright in the IEEE's name any IEEE Standards publication even though it may include portions of this contribution; and at the IEEE's sole discretion to permit others to reproduce in whole or in part the resulting IEEE Standards publication. The contributor also acknowledges and accepts that this contribution may be made public by IEEE 802.16.
Patent Policy and Procedures	<p>The contributor is familiar with the IEEE 802.16 Patent Policy and Procedures (Version 1.0) <http://iee802.org/16/ipr/patents/policy.html>, including the statement "IEEE standards may include the known use of patent(s), including patent applications, if there is technical justification in the opinion of the standards-developing committee and provided the IEEE receives assurance from the patent holder that it will license applicants under reasonable terms and conditions for the purpose of implementing the standard."</p> <p>Early disclosure to the Working Group of patent information that might be relevant to the standard is essential to reduce the possibility for delays in the development process and increase the likelihood that the draft publication will be approved for publication. Please notify the Chair <mailto:r.b.marks@ieee.org> as early as possible, in written or electronic form, of any patents (granted or under application) that may cover technology that is under consideration by or has been approved by IEEE 802.16. The Chair will disclose this notification via the IEEE 802.16 web site <http://iee802.org/16/ipr/patents/notices>.</p>

Table of Contents

1 Motivation	43
2 Overview of the proposed solution	54
2.1 Support H-ARQ and multiple maps in the normal map	54
2.2 Optimizing IE overhead of H-ARQ burst allocation	64
2.3 MAC implications of H-ARQ operation	65
3 Remedy 1: Text Changes for H-ARQ and telescopic maps	76
3.1 H-ARQ Support in Normal MAP	76
3.1.1 H-ARQ DL MAP Extension	76
3.1.2 H-ARQ UL MAP Extension	1312
3.1.3 UL H-ARQ ACK channel definition	1615
3.1.3.1 H-ARQ ACK Region Allocation IE	1615
3.1.4 DL H-ARQ ACK IE Format	1716
3.1.5 Overview of Chase H-ARQ and definition of CRC	1817
3.1.5.1 Distinction between IR and Chase H-ARQ	1919
3.1.5.2 Changes to distinguish existing ChaseChase-HARQ scheme from the new one	1919
3.2 Sub-MAP Message	2019
3.2.1 Sub-MAP Message	2019
3.2.2 Sub-MAP Pointer IE	2323

3.2.3 UL MAP Fast tracking IE	2425
3.3 Capability Negotiation	2626
3.3.1 MAP Capability	2626
3.3.2 H-ARQ Burst and Buffer Capability	2627
3.4 MAC implications of H-ARQ operation	3029
3.4.1 Changes overview	3029
3.4.1.1 Replay Attack Windowing	3029
3.4.2 Specific text changes to the Standard	3030
1 Motivation	23
2 Overview of the proposed solution	23
2.1 Support H-ARQ and multiple maps in the normal map	23
2.2 Optimizing IE overhead of H-ARQ burst allocation	24
2.3 MAC implications of H-ARQ operation	25
3 Text Change	26
3.1 H-ARQ Support in Normal MAP	26
3.1.1 H-ARQ DL MAP Extension	26
3.1.2 H-ARQ UL MAP Extension	3.1.1.1 Dedicated DL Control IE
.....	Error! Bookmark not defined.
3.1.3 UL H-ARQ ACK channel definition	3.1.2 H-ARQ UL MAP Extension
.....	28
3.1.3.1 H-ARQ ACK Region Allocation IE	3.1.2.1 Dedicated UL Control IE
.....	Error! Bookmark not defined.
3.1.4 DL3 UL H-ARQ ACK IE Format	channel definition
.....	210
3.1.5 Overview of Chase H-ARQ and definition of CRC	3.1.3.1 H-ARQ ACK Region Allocation IE
.....	211
3.1.5.1 Distinction between IR and Chase H-ARQ	3.1.4 DL H-ARQ ACK IE Format
.....	212
3.1.5.2 Changes to distinguish existing Chase HARQ scheme from the new one	3.1.5 Overview of
CC H-ARQ and definition of CRC	212
3.2 Sub-MAP Message	3.1.5.1 Distinction between IR and CC H-ARQ
.....	213
3.2.1 Sub-MAP Message	3.1.5.2 Changes to distinguish existing CC HARQ scheme from the new one
.....	213
3.2.2 Sub-MAP Pointer IE	Message
.....	214
3.2.3 UL 1 Sub-MAP Fast tracking IE	Message
.....	214
3.3 Capability Negotiation	3.2.2 Sub-MAP Pointer IE
.....	216
3.3.1 MAP Capability Negotiation	216
3.3.2 H-ARQ Burst and Buffer	1 MAP Capability
.....	216
3.4 MAC implications of H-ARQ operation	3.3.2 H-ARQ Burst and Buffer Capability
.....	217
3.4.1 Changes overview	3.4 MAC implications of H-ARQ operation
.....	218
3.4.1.1 MAC-ARQ Mode for H-ARQ	3.4.1 Changes overview
.....	218
3.4.1.2 Fast 1 MAC-ARQ Mode for H-ARQ	218

3.4.1.3 Replay Attack Windowing	2 Fast ARQ
.....	218
3.4.1.4 Extended Subheader Field (ESF)	3.4.1.3 Replay Attack Windowing
.....	219
3.4.2 Specific text changes to the Standard	3.4.1.4 Extended Subheader Field (ESF)
.....	219
3.4.2 Specific text changes to the Standard	219

1 Motivation

In 802.16e there are two sets of maps: the normal maps and optional H-ARQ maps. However none of the maps supports a complete set of features. For example, the mandatory PUSC/FUSC permutations, two dimensional allocations, boosting and AAS are supported only by the normal maps, whereas is H-ARQ, as well as the ability to define multiple downlink maps are supported only by the H-ARQ map.

The purpose of this contribution is to define a single map that supports both feature sets. For this purpose we add the most important functionalities of the H-ARQ map to the normal map. The functionalities are:

- Incremental redundancy H-ARQ for CTC
- Chase combining H-ARQ for all coding schemes.
- Multiple map support.

H-ARQ enables to improve the performance of ARQ based links. Multiple maps enable to use maps at different burst profiles instead of one map at the most robust burst profile, and thus reduce the map overhead (see contribution C80216e-04/468).

H-ARQ also has various effects on the 802.16 MAC. These include MAC PDU reordering, sequencing and encryption implications. Section 2.2 of this document describes these problems and proposes solutions that will allow the current MAC to operate with H-ARQ.

2 Overview of the proposed solution

The proposed text changes

This contribution includes two parts of text changes:

Remedy 1: Changes to introduce H-ARQ and telescopic maps into the normal map.

Remedy 2: Changes to add fast ARQ using similar elements as H-ARQ.

2.1 Support H-ARQ and multiple maps in the normal map

The support for H-ARQ is enabled by adding the following IEs to the normal map:

- H-ARQ DL/UL IE to make the burst allocations and supply H-ARQ control information
- ACKCH allocation IE to allocate uplink ACK channels
- H-ARQ ACK IE to indicate the downlink ACK/NACKs

The support for multiple maps is enabled by a modification of the H-ARQ map pointer IE. Following the modification the IE can point to a map including normal DL/UL MAP_IEs. The sub-map has a similar structure to the DL/UL maps, but without the fixed overhead.

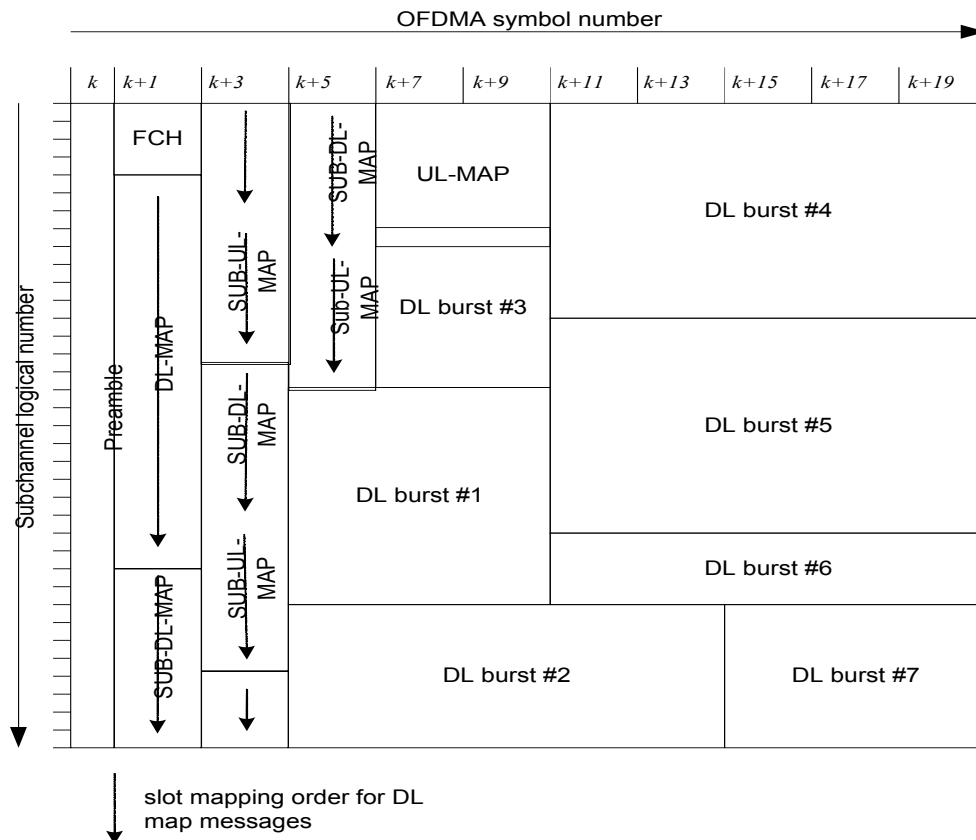

2.2 Optimizing IE overhead of H-ARQ burst allocation

Two dimensional (2D) allocations that exist in the normal map enable to reduce the interference between cells by correctly adopting the number of used subchannels and the boosting level of each, however the overhead of allocating 2D allocations is large. H-ARQ requires to allocate a PHY burst for each subscriber, rather than concatenate the PDUs of several subscribers to reduce overhead.

Therefore the proposed solution is a two level allocation: to first define a 2D region, and then partition this region in a 1D frequency-first manner into bursts. All the bursts in the 2D allocation share the same burst profile and boosting parameters (similar to PDU concatenation in non-HARQ burst).

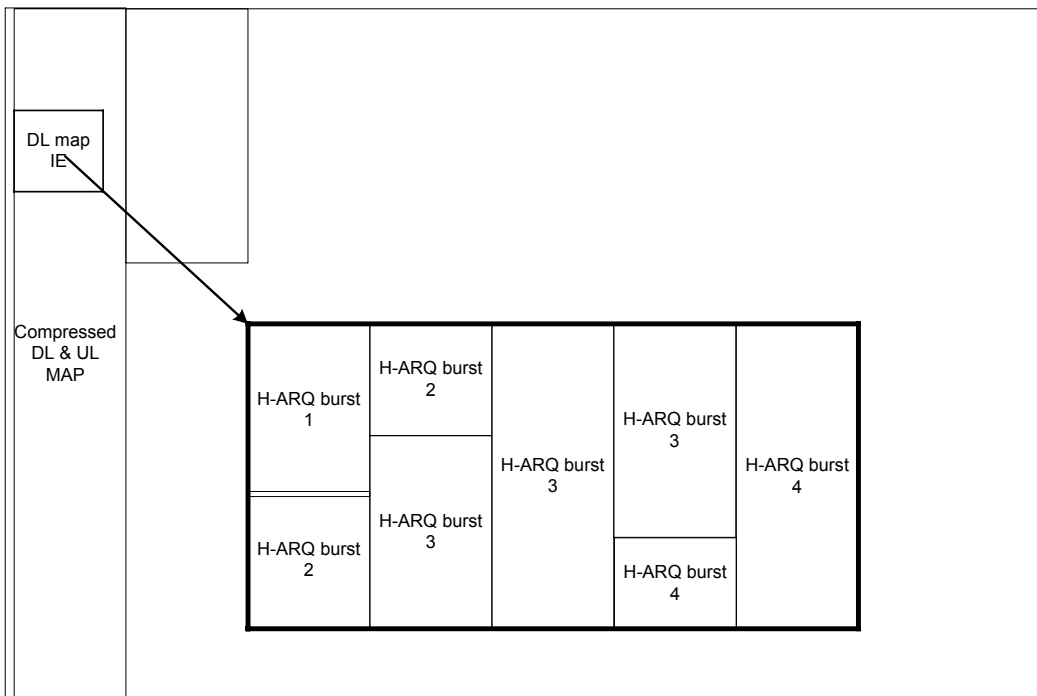

2.3 MAC implications of H-ARQ operation

H-ARQ is commonly used in cellular networks to provide additional protection for data connections under the highly dynamic link situations that a mobile platform introduces. As such, it is deemed as an important feature in 802.16. However, initial 802.16 MAC definitions have not taken H-ARQ into consideration and a wide set of problems exists in supporting H-ARQ with the current MAC definitions.

When using H-ARQ, the MAC receives PDUs from the PHY without any guarantee for ordering. This is due to the fact that the PHY is itself responsible for retransmissions of PDUs and thus can disrupt their order.

To deal with this, several fixes are needed:

1) Since Encryption is normally defined in 802.16 for ordered PDUs, the Replay Attack detection will be triggered when de-encrypting PDUs out of order. The proposed solution is to define a Replay Attack window (See below).

2) It is required to use some sort of sequencing over H-ARQ connections to be able to re-order PDUs at the receiving MAC. The proposed solution is to use standard 802.16 ARQ (MAC-ARQ) mechanisms for sequencing.

3) It is required to use some sort of time-keeping and synchronization between transmitter and receiver to be able to track the state of lost PDUs which the H-ARQ layer has not been able to recover. The proposed solution is to use standard 802.16 ARQ mechanisms (BLOCK_LIFETIME, SYNC_LOSS_TIMEOUT, DISCARD messages) for this.

The recommendation is thus to use standard 802.16 ARQ (MAC-ARQ) over H-ARQ connections. This mode has some special requirements and limitations which are listed below.

Capitalizing on this approach, this document proposes an additional improvement to the ARQ mechanism in the form of Fast-ARQ. Fast-ARQ can be used instead of H-ARQ but uses the H-ARQ defined ACK channel for drastically improving on regular MAC-ARQ performance and cost.

3 [Remedy 1: Text Changes for H-ARQ and telescopic maps](#)

3.1 H-ARQ Support in Normal MAP

3.1.1 H-ARQ DL MAP Extension

[Add a new section 8.4.5.3.20 9 as follows]

[8.4.5.3.209 H-ARQ DL Support in Normal MAP IE](#)
[The following modes of H-ARQ are supported by the](#)

[8.4.5.9.1 H-ARQ DL MAP IE: Extension](#)

1. [Chase combining H-ARQ for all FEC types \(H-ARQ Chase\). In this mode the burst profile is indicated by a DIUC.](#)
2. [Incremental redundancy H-ARQ with CTC \(H-ARQ IR\). In this mode the burst profile is indicated by the parameters \$N_{ep}\$, \$N_{sch}\$.](#)
3. [Incremental redundancy H-ARQ for convolutional code \(H-ARQ CC-IR\).](#)

[The IE may also be used to indicate ~~also~~ a non-HARQ transmission.](#)

[The H-ARQ DL MAP IE defines one or more two dimensional data regions ~~allocations~~ \(a number of symbols by a number of subchannels\). ~~When the mode field indicates H-ARQ IR or Chase \(mode = 10,11\), t~~These allocations are further partitioned into bursts, termed sub-bursts, by allocating a specified number of slots to each burst. . All sub-bursts of a data region shall only support one of the H-ARQ modes. The number of slots is indicated by duration or \$N_{sch}\$ fields. The slots are allocated in a frequency-first order, starting from the slot with the smallest symbol number and smallest subchannel, and continuing to slots with increasing subchannel number. When the edge of the allocation is reached, the symbol number is increased by a slot duration, as depicted in the following diagram. Each sub-burst is separately encoded.](#)

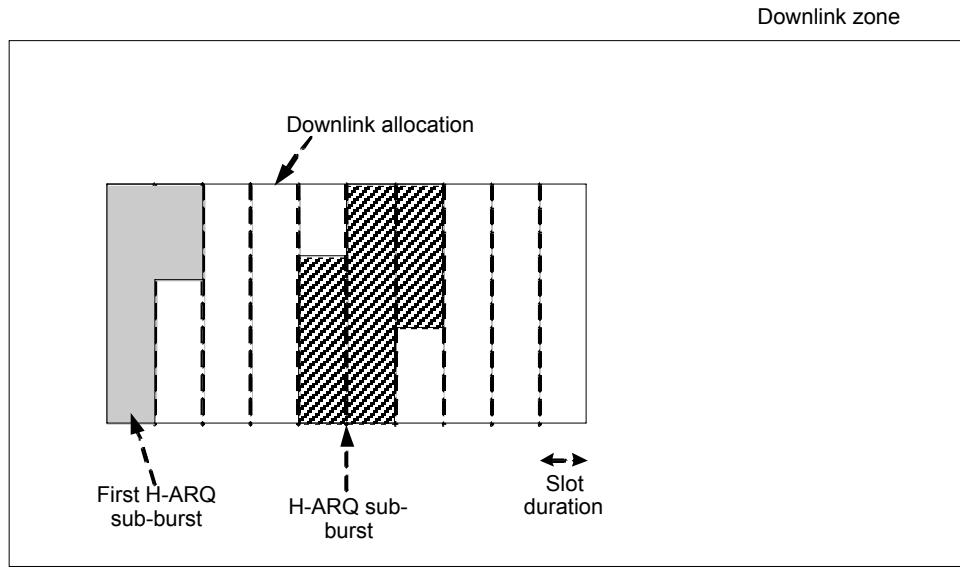

Figure XX – H-ARQ downlink allocation

Table 306a H-ARQ DL MAP IE Format

Syntax	Size	Note
H-ARQ DL MAP IE {		
Extended DIUC ₂	Variable 4	Set to 0x14 bits if this IE inside a Main MAP 6 bits if this IE inside a Sub MAP
Length	Variable 8	4 bits if this IE inside a Main MAP 8 bits if this IE inside a Sub MAP Length of the IE in bytes
RCID_Type	2 bits	00 = Normal CID 01 = RCID11 10 = RCID7 11 = RCID3
While (data remains) {		Number of allocations is deducted from the length field.
OFDMA Symbol offset	8 bits	Offset from the start symbol of DL sub-frame
Subchannel offset	6 bits	
Boosting	3 bits	000: normal (not boosted); 001: +6dB; 010: +6dB; 011: +9dB; 100: +3dB; 101: -3dB; 110: -9dB; 111: -12dB;
No. OFDMA Symbols	7 bits	
No. Subchannels	6 bits	
N sub-burst{N+1}	3-5 bits	Number of sub-bursts in 2D region
Mode	3-2 bits	Indicates the mode of this IE 0 Bit #1: 0 = No H-ARQ 000 = Chase 1 = H-ARQ 1001 = Incremental redundancy H-ARQ for CTC 2010 = Incremental redundancy H-ARQ for convolutional code 3011 - 15111 Reserved Bit #0: 0 = DIUC/Length, 1 = Nsp/Nsch
If (Mode == 000) {		

DL-DIUC Sub-Burst IE ()	Variable	-
} else if (Mode == 10) {		
DL H-ARQ Chase CC Sub-Burst IE ()	Variable	
} else if (Mode == 10011) {		
DL H-ARQ IR CTC Sub-Burst IE ()	Variable	
} else if (Mode == 2010) {		
DL H-ARQ IR CC Sub-Burst IE ()	Variable	
}		
Padding	Variable	Padding to byte; shall be set to 0
}		

Table 306b DL-DIUC Sub-Burst IE Format

DL-DIUC Sub-Burst IE {		
DIUC	4 bits	
Repetition Coding Indication	2 bits	0b00 – No repetition coding 0b01 – Repetition coding of 2 used 0b10 – Repetition coding of 4 used 0b11 – Repetition coding of 6 used
For (j=0; j<N-sub-burst; j++){		
RCID_IE()	Variable	
– Dedicated Control Indicator	1 bit	
If (Dedicated Control Indicator == 1) {		
Dedicated Control IE ()	Variable	
}		
}		
}		

Table 306c DL H-ARQ Chase ~~CC~~ Sub-Burst IE Format

DL H-ARQ Chase CC Sub-Burst IE {		
DIUC	4 bits	
Repetition Coding Indication	2 bits	0b00 – No repetition coding 0b01 – Repetition coding of 2 used 0b10 – Repetition coding of 4 used 0b11 – Repetition coding of 6 used
<u>N sub-burst[IS2]</u>	<u>5 bits</u>	<u>Number of sub-bursts in 2D region</u>
For (j=0; j<N sub-burst; j++){		
RCID_IE()	Variable	
Duration (in slots)	10 bits	<u>Duration in slots</u>
ACID	4 bits	
AI_SN	1 bit	
<u>COICH Control Indicator</u>	<u>1 bits</u>	
<u>If (COICH Control Indicator == 1) {</u>		
<u>Allocation Index</u>	<u>6 bits</u>	<u>Index to the channel in a frame the COI report should be transmitted by the SS</u>
<u>Period (p)</u>	<u>3 bits</u>	<u>A COI feedback is transmitted on the COI channels indexed by the (COI Channel Index) by the SS in every 2^p frames.</u>

<u>Frame offset</u>	3 bits	The MSS starts reporting at the frame of which the number has the same 3 LSB as the specified frame offset. If the current frame is specified, the MSS should start reporting in 8 frames.
<u>Duration (d)</u>	4 bits	A CQI feedback is transmitted on the CQI channels indexed by the (CQI Channel Index) by the SS for $2^{(d-1)}$ frames. If d is 0b0000, the CQICH is de-allocated. If d is 0b1111, the MSS should report until the BS command for the MSS to stop
}		
Dedicated <u>DL</u> Control Indicator	1 bit	
If (Dedicated <u>DL</u> Control Indicator ==1) {		
Dedicated <u>DL</u> Control IE ()	Variable	
}		
}		
}		

Table 306d DL H-ARQ IR CTC Sub-Burst IE Format

DL H-ARQ IR Sub-Burst IE {		
<u>N sub burst</u>	5 bits	
For (j=0; j<N sub burst; j++){		
RCID_IE()	Variable	
Nep	4 bits	
Nsch	4 bits	
SPID	2 bits	
ACID	4 bits	
AI_SN	1 bit	
<u>CQICH Control Indicator</u>	1 bits	
If (CQICH Control Indicator == 1) {		
<u>Allocation Index</u>	6 bits	Index to the channel in a frame the CQI report should be transmitted by the SS
<u>Period (p)</u>	3 bits	A CQI feedback is transmitted on the CQI channels indexed by the (CQI Channel Index) by the SS in every 2^p frames.
<u>Frame offset</u>	3 bits	The MSS starts reporting at the frame of which the number has the same 3 LSB as the specified frame offset. If the current frame is specified, the MSS should start reporting in 8 frames.
<u>Duration (d)</u>	4 bits	A CQI feedback is transmitted on the CQI channels indexed by the (CQI Channel Index) by the SS for $2^{(d-1)}$ frames. If d is 0b0000, the CQICH is de-allocated. If d is 0b1111, the MSS should report until the BS command for the MSS to stop
}		
Dedicated <u>DL</u> Control Indicator	1 bit	
If (Dedicated <u>DL</u> Control Indicator ==1) {		

Dedicated DL Control IE ()	Variable	
}		
}		
}		

Table 306e DL H-ARQ Chase-IR CC Sub-Burst IE Format

<u>DL H-ARQ Chase-IR CC Sub-Burst IE</u> {		
<u>DIUC</u>	4 bits	
<u>Repetition Coding Indication</u>	2 bits	0b00 – No repetition coding 0b01 – Repetition coding of 2 used 0b10 – Repetition coding of 4 used 0b11 – Repetition coding of 6 used
<u>N sub burst</u>	5 bits	
For (j=0; j<N sub burst; j++){		
<u>RCID IE()</u>	Variable	
<u>Duration</u>	10 bits	<u>Duration in slots</u>
<u>ACID</u>	4 bits	
<u>AI_SN</u>	1 bit	
<u>SPID</u>	2 bits	
<u>COICH Control Indicator</u>	1 bits	
<u>If (COICH Control Indicator == 1) {</u>		
<u>Allocation Index</u>	6 bits	<u>Index to the channel in a frame the COI report should be transmitted by the SS</u>
<u>Period (p)</u>	3 bits	<u>A COI feedback is transmitted on the COI channels indexed by the (COI Channel Index) by the SS in every 2^p frames.</u>
<u>Frame offset</u>	3 bits	<u>The MSS starts reporting at the frame of which the number has the same 3 LSB as the specified frame offset. If the current frame is specified, the MSS should start reporting in 8 frames.</u>
<u>Duration (d)</u>	4 bits	<u>A COI feedback is transmitted on the COI channels indexed by the (COI Channel Index) by the SS for 2^(d-1) frames. If d is 0b0000, the COICH is de-allocated. If d is 0b1111, the MSS should report until the BS command for the MSS to stop</u>
<u>}</u>		
<u>Dedicated DL Control Indicator</u>	1 bit	
<u>If (Dedicated DL Control Indicator == 1) {</u>		
<u>Dedicated DL Control IE ()</u>	Variable	
<u>}</u>		
<u>}</u>		
<u>}</u>		

[End of “Add a new section 8.4.5.3.209 as follows”]

Dedicated DL Control IE contains additional control information for each sub-burst in the tables above.. Because each sub-burst may have its own control information format dependent on the MSS capability, the length of the Dedicated DL Control IE is variable.

[Add a new section 8.4.5.3.209-1.1 as follows]

8.4.5.3.209-1.1 Dedicated DL Control IE

Table 306e Dedicated DL Control IE Format

Syntax	Size	Note
Dedicated DL Control IE() {		
Length	4 bits	Length of following control information in Nibble.
Control Header	4 bits	Bit #0: SDMA Control Info Bit #1-3: Reserved
Length	4 bits	Length of following control information in Nibble.
Control Header	4 bits	Bit #0: CQICH Control Info Bit #1: SDMA Control Info Bit #12-3: Reserved
If (CQICH Control Info Bit == 1){		
Allocation Index	6 bits	
Period (e)	32 bits	
Frame offset	3 bits	
Duration (d)	4 bits	
}		
If (SDMA Control Info Bit == 1){		
Num SDMA layers	2 bit	Number of SDMA layers minus 1
}		
Padding bits	variable	
}		

Control Indicator

4 bits are used to indicate the following control information. If the first bit is set to 1, this means that CQICH Control information follows Control Indicator. Other bits are reserved for future extension.

Allocation Index

Indicates position from the start of the CQICH region.

Period

Indicates the SS of the period of CQI reports. ~~CQI feedback is transmitted on the CQICH once every 2^p frames.~~

Frame Offset

Indicates the SS when to start transmitting reports. The SS starts reporting at the frame number which has the same 3 LSBs as the specified Frame Offset. If the current frame is specified, the SS shall start reporting in 8 frames.

Duration

Indicates when the SS should stop reporting unless the CQICH allocation is refreshed beforehand. If Duration is set to 0b0000, the BS shall de-allocate the CQICH. If Duration is set to 0b1111, the CQICH is allocated indefinitely and the SS should report until it receives another MAP_IE with Duration set to 0b0000. ~~Otherwise the duration equals $10 * 2^d$ frames.~~

Num SDMA layers

This field shall appear for the first sub burst in each layer of an SDMA allocation, and indicates activation of SDMA. Each SDMA layer has a different pilot pattern (layer n uses pilot pattern n). The appearance of another burst with Num SDMA layers indicates a new SDMA layer. The number of SDMA layer is incremented and the

symbol and subchannel offsets are reset to the beginning of the allocation. The Num SDMA layers appearing in first burst of each layer must be equal.

8.4.5.3.20.2 Reduced CID IE

[Copy the contents of section 6.3.2.3.43.3 (Reduced CID), renumber the tables and figures accordingly]

[End of “Add a new section 8.4.5.3.20.1.1 as follows”]

3.1.2 H-ARQ UL MAP Extension

[Add a new section 8.4.5.4.2.3 as follows]

8.4.5.4.2.3 H-ARQ UL MAP Extension

Table 3061 H-ARQ UL MAP IE

The following modes of H-ARQ are supported by the H-ARQ UL MAP IE:

1. Chase combining H-ARQ for all FEC types (H-ARQ Chase). In this mode the burst profile is indicated by a DIUC.
2. Incremental redundancy H-ARQ for CTC (H-ARQ IR). In this mode the burst profile is indicated by the parameters Nep, Nsch.
3. Incremental redundancy H-ARQ for convolutional code (H-ARQ CC-IR).

The IE may also be used to indicate also a non-HARQ transmission.

The H-ARQ DL-UL MAP IE defines one or more bursts. Each burst is separately encoded.

When Allocation Start Indication is '1', the H-ARQ UL MAP IE indicates the starting symbol and subchannel of the allocation. The starting symbol and subchannel shall indicate a valid slot location in the uplink subframe. The slots are allocated in a time-first order (as specified in 8.4.5.4). The starting symbol and subchannel are relevant only in the context of the H-ARQ UL MAP IE in which they appear. Allocations made without an Allocation Start Indication (such as H-ARQ UL MAP IE with Allocation Start Indication '0', or regular UL-MAP IE), shall ~~keep an independent~~ based on the global slot index, ~~i.e.~~ each of these allocations shall follow the last allocation which didn't contain Allocation Start indication.

Table 3061 H-ARQ UL MAP IE^[IS3]

Syntax	Size	Note
H-ARQ UL MAP IE() {		
Extended UIUC	Variable 4	4 bits if this IE inside a Main MAP 6 bits if this IE inside a Sub MAP Set to 0x1
Length	Variable 8	Indicates the length of the IE in bytes4 bits if this IE inside a Main MAP 8 bits if this IE inside a Sub MAP
RCID_Type	2 bits	00 = Normal CID 01 = RCID11 10 = RCID7 11 = RCID3
while (data remains) {		
Allocation Start Indication	1 bit	0: No allocation start information

		1: Allocation start information follows
If (Allocation Start Indication == 1) {		
OFDMA Symbol offset	8 bits	This value indicates start Symbol offset of subsequent sub-bursts in this H-ARQ UL MAP IE
Subchannel offset	76 bits	This value indicates start Subchannel offset of subsequent sub-bursts in this H-ARQ UL MAP IE
}		
Mode	3 bits	Indicates the mode of this IE each burst Bit #1: 0 = No H-ARQ 000 = Chase Combining = H-ARQ 001 = Incremental redundancy H-ARQ for CTC 010 = Incremental redundancy H-ARQ for convolutional code 011 – 111 Reserved Bit #0: 0 = DUUC/Length, 1 = Ncp/Nsch
N_sub_Burst	4 bits	This field indicates the number of bursts in this UL MAP IE
For (i =0 ;i < N Sub-burst; i++){		
_RCID IE()	Variable	
Dedicated UL Control Indicator	1 bit	
If (Dedicated UL Control Indicator ==1) {		
_Dedicated UL Control IE ()	variable	
} else if (Mode == 000) {		
UL UIUC Sub-Burst IE ()		
} else if (Mode == 10) {		
UL HARQ Chase Combining Sub-Burst IE ()		
} else if (Mode == 001) {		
UL HARQ IR CTC Sub-Burst IE ()		
} else if (Mode == 010) {		
UL HARQ IR CC Sub-Burst IE ()		
}		
}		
Padding	Variable	Padding to byte; shall be set to 0
}		

Table 306m UL UIUC Sub-Burst IE Format

UL UIUC Sub-Burst IE {		
UIUC	4 bits	
Repetition Coding Indication	2 bits	0b00 — No repetition coding 0b01 — Repetition coding of 2 used 0b10 — Repetition coding of 4 used 0b11 — Repetition coding of 6 used
Duration	10 bits	

†			

Table 306n UL HARQ Chase~~CC~~ Sub-Burst IE Format

HARQ Chase CC UL Sub-Burst IE {			
UIUC	4 bits		
Repetition Coding Indication	2 bits	0b00 – No repetition coding 0b01 – Repetition coding of 2 used 0b10 – Repetition coding of 4 used 0b11 – Repetition coding of 6 used	
Duration	10 bits		
ACID	4 bits		
AI_SN	1 bit		
}			

Table 306o UL HARQ IR CTC Sub-Burst IE Format

HARQ IR UL Sub-Burst IE {			
Nep	4 bits		
Nsch	4 bits		
SPID	2 bits		
ACID	4 bits		
AI_SN	1 bit		
}			

Table 306o UL HARQ IR CC Sub-Burst IE Format

HARQ Chase UL Sub-Burst IE {			
UIUC	4 bits		
Repetition Coding Indication	2 bits	0b00 – No repetition coding 0b01 – Repetition coding of 2 used 0b10 – Repetition coding of 4 used 0b11 – Repetition coding of 6 used	
Duration	10 bits		
SPID ACID	2 bits 4 bits		
ACID AI_SN	4 bits 1 bit		
AI_SN —SPID	1 bit 2 bits		
}			

[End of “Add a new section 8.4.5.4.29-3 as follows”]

Dedicated UL Control IE contains additional control information for each sub bursts.

[Add a new section 8.4.5.4.29-3.1 as follows]

8.4.5.4.29-3.1 Dedicated UL Control IE

Table 306p Dedicated UL Control IE Format

Syntax	Size	Note
Dedicated UL Control IE() {		
Length	4 bits	Length of following control information in Nibble.
Length	4 bits	Length of following control information in Nibble.
Control Header	4 bits	Bit #0 #3: Reserved
Control Information	Variable	
}		

Length

This field indicates the following control information ~~including Control Header.~~

Control Information

Variable size control information.

Control Header

~~4 bits are used to indicates following control information. All bits are reserved for future extension.~~

[End of “Add a new section 8.4.5.4.29.3.1 as follows”]

3.1.3 UL H-ARQ ACK channel definition**3.1.3.1 H-ARQ ACK Region Allocation IE**

[Add a new section 8.4.5.4.249.5 as follows]

8.4.5.4.249.5 HARQ ACK Region Allocation IE

This IE is used by BS to define a UL region to include one or more ACK channel(s) for H-ARQ supporting MSS. The IE format is shown in Table 306w. The slots in the ACKCH region are divided into two half-slots. The first half-slot is composed of tiles 012345; the second half-slot is composed of tiles 123456. In the ACKCH Region, ACK channel 2n is the first half of slot n; ACK channel (2n+1) is the second half of slot n. The slot number n is increased first along the time axis until the end of the ACKCH region, and then along the subchannel axis.

The H-ARQ enabled MSS that receives H-ARQ DL burst at frame "i" should transmit the ACK signal through the ACK channel in the ACKCH region at frame (i+j). The frame offset 'j' is defined by the “H-ARQ ACK Delay for DL Burst” field in the UCD message.

The half-subchannel offset in the ACKCH Region is determined by the order of H-ARQ enabled DL burst in the DL MAP. For example, when a MSS receives a H-ARQ enabled burst at frame i, and the burst is the n-th H-ARQ enabled burst among the H-ARQ related IEs, the MSS should transmit H-ARQ ACK at n-th half-subchannel in ACKCH Region that is allocated by the BS at frame (i+j).

~~In case of Fast ARQ the “half suchannel offset” is to be specified via an absolute value in the Extended Sub header of the PDU.~~

Each SS should specify support of either “UL ACK” channel, or “Enhanced UL ACK” (see 11.8.3.7.9). A subscriber supporting Enhanced UL ACK shall always transmit Enhanced UL ACK as defined in 8.4.5.4.17.

Table 306w. HARQ ACKCH_region MAP IE format.

Syntax	Size (bits)	Note
<u>HARQ ACKCH Region IE() {</u>		
<u>Extended UIUC</u>	4	
<u>Length</u>	4	0x3
<u>OFDMA Symbol offset</u>	8	
<u>Subchannel offset</u>	7	
<u>No. OFDMA symbols</u>	5	
<u>No. subchannels</u>	4	
<u>}</u>		

OFDMA Symbol offset

Subchannel offset

No. OFDMA Symbols

No. Subchannels

Specify the start symbol offset, the start subchannel offset, the number of allocated symbols and the number of subchannels for the H-ARQ acknowledgement region respectively.

3.1.4 DL H-ARQ ACK IE Format

[Add a new section 8.4.5.3.21~~9-6~~ as follows]

8.4.5.3.21~~9-6~~ DL H-ARQ ACK IE

This IE is used by BS to send H-ARQ acknowledgment to UL H-ARQ enabled traffic. The bit position in the bitmap is determined by the order of the H-ARQ enabled UL bursts in the UL-MAP. The frame offset "j" between the UL burst and the H-ARQ ACK-BITMAP is specified by “H-ARQ_ACK_Delay_for UL Burst” field in the DCD message. For example, when a MSS transmits a H-ARQ enabled burst at frame i and the burst is the n-th H-ARQ enabled burst in the MAP, the MSS should receive H-ARQ ACK at n-th bit of the BITMAP which is sent by the BS at frame (i+j).

The existence of this IE shall be optional.

If~~When~~ the H-ARQ ACK BITMAP IE is omitted, the H-ARQ~~absent~~, MSS should retain the transmitted H-ARQ burst and retransmit it when~~shall assume that the UL H-ARQ is not received by~~ the BS request retransmission with AI_SN. This IE may only be exist in the DL-MAP message.

Table 306x. H-ARQ_ACK IE format.

Syntax	Size (bits)	Note
Generic H-ARQ_ACK_IE() {		
Extended DIUC	4	
Length	4	
Bitmap	Variable	
}		

BITMAP

Includes H-ARQ ACK information for H-ARQ enabled UL bursts. The size of BITMAP should be equal or larger than the number of H-ARQ enabled UL-bursts. Each byte carries 8 ACK indications ordered from LSB (smallest index ACK channel) to MSB.

3.1.5 Overview of Chase CC-H-ARQ and definition of CRC

[Add new section 8.4.15.9.7 as follows]

8.4.15.9.7 Optional CC-H-ARQ support

The following optional modes exist for ~~(Chase combining~~-H-ARQ

- [Incremental redundancy for CTC – specified in 6.3.17 and in 8.4.9.2.3.5.](#)
- [Incremental redundancy for CC \(convolutional code\) – specified in 8.4.15.2 and 8.4.9.2.1.2](#)
- [Chase combining for all coding schemes specified in 8.4.15.1](#)

[These modes can be supported by the normal map and the H-ARQ map.](#)

8.4.15.1 Optional Chase H-ARQ Support

The optional Chase CC H-ARQ scheme enables BS and SS to enhance performance of ARQ based connection by means of chase combining scheme. This scheme is supported for all coding schemes. Each burst is appended with a CRC which is checked by the receiver. An uplink and a downlink ACK channels are defined (see 8.4.5.4.13 and 8.4.5.4.17). The receiver replies with an ACK in the corresponding ACK channel if the decoding succeeded and with a NACK if the decoding failed.

If the burst was not ACK-ed, the transmitter may transmit a burst with exactly the same data contents again. The receiver may combine the newly received burst with the formerly received burst(s) to enhance decoding performance.

8.4.15.1.5.9.7.1 H-ARQ Retransmission process

The process of retransmissions is controlled by the BS using the ACID (ARQ Channel ID) and AI_SN fields in the DL and UL maps. Each ARQ channel (indicated by specific ACID of 0-15) is managed separately.

When the AI_SN field in the H-ARQ channel remains the same between two H-ARQ burst allocations it indicates retransmission. In this case in the transmitter is required to retransmit the same data that was transmitted using the same ACID and AI_SN. The burst profile of the retransmission must be the same as in the first transmission, however the level of boosting and repetition may be changed.

When the AI_SN field in the H-ARQ channel is changed, it indicates transmission of new data. In this case the data stored in the transmitter and receiver for this ACID and the previously used AI_SN may be discarded.

8.4.15.1.5.9.7.2 CRC

Bursts transmitted using Chase~~CC~~ H-ARQ shall include CRC of 16 bits. The CRC is appended to MAC data after padding (before partitioning to FEC blocks and encoding as defined in 8.4.9). Padding is done so that the total length after CRC concatenation matches the size of the burst indicated by the map.

The CRC shall be CRC16-CCITT, as defined in ITU-T Recommendation X.25, and it is calculated over all the bits in the burst.

This CRC shall be used for error detection and for ACK/NACK transmission.

8.4.15.1~~5.9.7.3~~ **Concurrent transmission of UL H-ARQ bursts**

The BS may allocate more than one UL H-ARQ burst for a SS (see 8.4.4.5). The maximal number of UL bursts supported by an H-ARQ enabled SS is indicated by the capability field in 11.8.3.7.12 and includes both H-ARQ and non-HARQ bursts.

8.4.15.1~~5.9.7.4~~ **Encoding**

When using Chase~~CC~~ H-ARQ with H-ARQ DL/UL IE in the normal maps the encoding scheme is indicated by DIUC/UIUC code and the encoding process shall be the same as in non-HARQ transmission with the same DIUC/UIUC.

8.4.15.2 Optional IR H-ARQ for CC (convolutional code)

This mode of operation is similar to Chase H-ARQ (see 8.4.15.1). The specifications in 8.4.15.1 apply to this mode, except for the following differences:

1. An SPID field is supplied by the H-ARQ DL/UL MAP IE.
2. The value of SPID may be arbitrarily changed by the BS between retransmissions.
3. The encoding process is based on the non-HARQ coding scheme, except for the changes indicated in 8.4.9.2.1.2.

3.1.5.1 Distinction between IR and Chase~~CC~~ H-ARQ

[Change the title and contents of 8.4.9.2.3.5 as following]

8.4.9.2.3.5 Optional IR H-ARQ (Incremental redundancy H-ARQ) Support

3.1.5.2 Changes to distinguish existing Chase~~CC~~ H-ARQ scheme from the new one

[Add the following words in the title of 8.4.9.2.1.2 (defining IR scheme for convolutional code)]

8.4.9.2.1.2 **Incremental Redundancy H-ARQ support (optional)**

[Make the following replacements in first column of table 316a]

1st retransmission SPID=0
2nd retransmission SPID=1
3rd retransmission SPID=2
4th retransmission SPID=3

[Add the following words in the title and contents of 8.4.9.6. This section defines some encodings for Chase combining ~~CC~~ H-ARQ that are needed only for working with H-ARQ map]

8.4.9.6 **Chase Combining HARQ using H-ARQ map (optional)**

Chase Combining HARQ may be enabled for any of the existing FEC modes. When Chase combining H-ARQ is indicated

by the H-ARQ map, a change in the H-ARQ mode is signaled using the “H-ARQ Compact_DL-MAP IE format for Switch H-ARQ Mode” (see section 6.3.2.3.43.6.7). The definitions of the H-ARQ modes are defined in Table 333.

3.2 Sub-MAP Message

3.2.1 Sub-MAP Message

[Add new section 6.3.2.3.59]

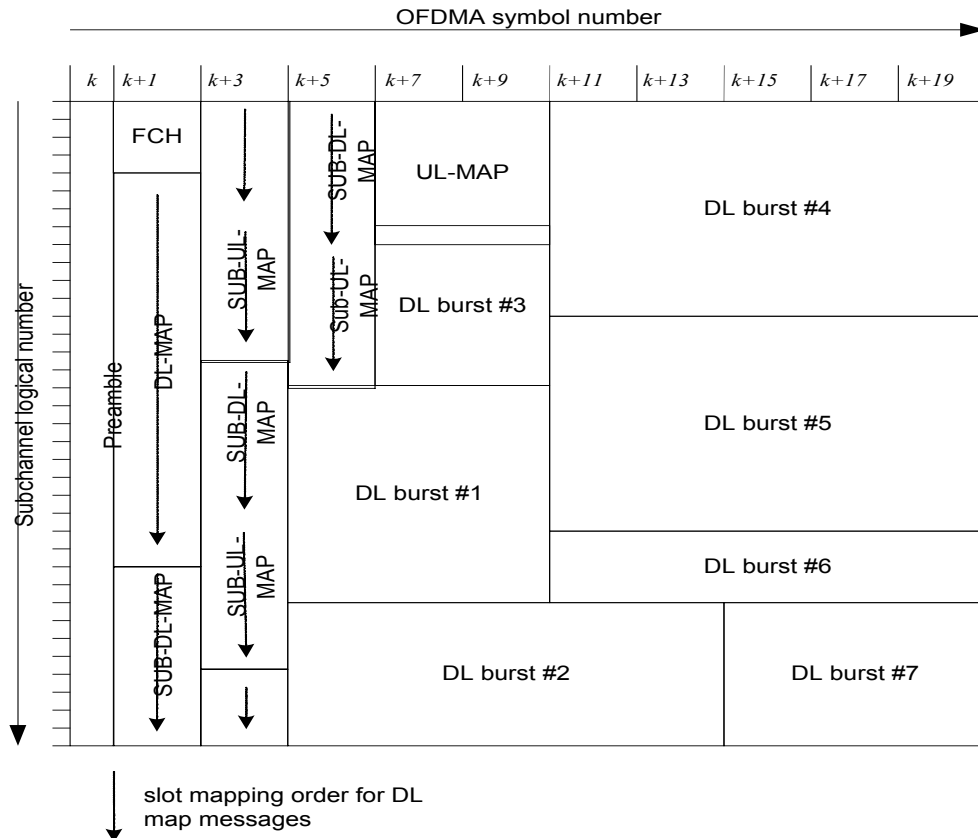

Figure 23a Sub-MAP Burst

6.3.2.3.59 Sub downlink/uplink map (SUB-DL-UL-MAP) message

This message shall only apply to OFDMA PHY.

The SUB-DL-UL-MAP message shall appear in a compressed form, in which the generic MAC header is omitted. This is indicated by setting the two most significant bits of the first data byte in the message’s PHY burst to 1 (an invalid combination for a generic MAC header).

The SUB-DL-UL-MAP format is presented in Table 107f.

Syntax	Size	Notes
SUB-DL-UL-MAP () {		
Compressed map indicator	3 bits	Set to binary 111 11 for compressed format
Map message length	10 bits	
Reserved	2 bits	Shall be set to 0
H-ARQ ACK offset indicator	1 bit	
If (H-ARQ ACK offset indicator == 1){		
DL H-ARQ ACK offset	8 bits	
UL H-ARQ ACK offset	8 bits	
}		
DL IE Count	8 bits	
For (i=1; i <= DL IE Count; i++)		
DL-MAP_IE()	Variable	
}		
UL starting slot Slot offset	11 bits	
Reserved	2 bits	Shall be set to 0
while (map data remains){		
UL-MAP_IE()	Variable	
}		
If !(byte boundary) {		
Padding Nibble	Variable	Padding to reach byte boundary.
}		
}		

Map message length

The length of the submap message in bytes including the compressed map indicator and the CRC.

H-ARQ ACK offset indicator

This field toggles the inclusion of H-ARQ offsets. If this field is '0', then the ACK offsets shall be follow the last allocation made by previous maps. An SS which failed to decode any of the previous maps shall disregard all H-ARQ allocations made by this map, if H-ARQ ACK offset indicator is '0'.

UL H-ARQ ACK offset

Indicates the ACK channel in the ACKCH Region that corresponds to the first H-ARQ enabled uplink burst specified in this map message.

DL H-ARQ ACK offset

Indicates the ACK bit index in the DL H-ARQ ACK IE that corresponds to the first H-ARQ enabled downlink burst specified in this map message.

DL IE Count

The number of DL-MAP_IE-s.

UL starting slot offset

Indicates the initial slot offset of the UL bursts defined in this map, in the zone starting from the first uplink symbol (except for H-ARQ UL MAP IE with Allocation Start Indication of '1').

A CCITT CRC 16 value is appended to the end of the burst. The CRC is computed across all bytes of the SUB-DL-UL-MAP message,.

The order of DL-MAP_IEs in the SUB-DL-MAP message shall conform to the order defined for the DL-MAP message in section 6.3.2.3.2.

The logical order in which MAC PDUs are mapped to the PHY layer bursts in the downlink is defined as the order of increasing start time of all PHY bursts in the frame regardless of the ~~DL-map~~ MAP message in which they are described. If two or more PHY bursts have the same start time, the logical order is determined according to the order of appearance in the concatenation of DL-MAP and all SUB-DL-UL-MAP messages.

The logical order in which MAC PDUs are mapped to the PHY layer bursts in the uplink is defined as the order of UL-MAP_IEs in the SUB-DL-UL-MAP message.

The SUB-DL-UL-MAP messages shall be allocated consecutively using the same uni-dimensional frequency-first slot mapping order used for the DL-MAP and H-ARQ MAP bursts. The first burst containing a SUB-DL-UL-MAP message shall be allocated immediately following the bursts containing H-ARQ MAP messages, or following the DL-MAP if no H-ARQ MAPs exist in the frame.

The INC_CID flag shall be reset to 0 in the beginning of each SUB-DL-UL-MAP message.

The physical modifier (PHY-MOD) shall be reset at the beginning of each SUB-DL-UL-MAP message and before the first UL-MAP_IE.

All DL and UL zone switch IEs (Extended DIUC 0x01, Extended UIUC 0x04) shall be defined in the main DL and UL MAPs. SUB-DL-UL-MAP shall comply with the main DL and UL MAP zone switch ~~configuration and may include UL zone switch IE for start of allocation indication~~. The SUB-DL-UL-MAP shall not include the downlink zone switch IE. Instead, the zone shall be identified by the symbol number (indicated in DL-MAP_IE and other IE-s defining allocations).

The DL-MAP_IEs in the SUB-DL-UL-MAP shall be ordered in the increasing order of the transmission start time of the relevant PHY burst/allocation. The uplink allocations in the SUB-DL-UL-MAP shall be ordered in increasing order of zones

~~DL Zone switch IEs (Extended DIUC 0x01) must not be included in the SUB-DL-UL-MAP. UL Zone switch IEs (Extended UIUC 0x04) may be included also in the SUB-DL-UL-MAP. The IE slot offset field sell be used to specify the start offset inside the zone.~~

The maximum number of SUB-DL-UL-MAP messages per frame is 3.

SUB-DL-UL-Sub-MAP message shall ~~must~~ be used only with compressed DL and appended UL MAP structure.

[Add a new section
~~Section 8.4.5.4.25-7]~~

8.4.5.2.25 UL Allocation start IE

~~[Modify table 292 as follows]~~

Syntax	Size	Notes
UL Allocation start ZONE_IE () {		
Extended UIUC	4 bits	TBDZONE = 0x04
Length	4 bits	variable Length = 0x02

OFDMA Symbol offset	8 bits	This value indicates start Symbol offset of subsequent sub-bursts in this UL Allocation start IE H-ARQ UL MAP IE
Subchannel offset If (This Zone IE appears in Sub-MAP) {	7 bits	This value indicates start Subchannel offset of subsequent sub-bursts in this UL Allocation start IE H-ARQ UL MAP IE
reserved Include Slot offset	1 bit	Shall be set to 0
} If (Include Slot offset == 1) {		

This IE shall not be used in UL-MAP; it may be used in SUB-DL-UL-MAP.

[Add the following to the end of section 8.4.5.4.7]

This IE should not be used within SUB-DL-UL-MAP.

[add the following to end of section 8.4.5.3.4 Transmit diversity (TD)/Zone switch IE format]

This IE should not be used within SUB-DL-UL-MAP

Slot offset	11 bits	The slot offset (according to data slot mapping order), relative to the start of the zone, from which to begin allocating data slots to subsequent allocations. Slot offset is implicitly set to zero if 'Include slot offset' = 0.
Reserved	5 bits	
{		
Else {		
Reserved	7 bits	
{		
} else {		
Permutation	2 bits	0b00 = PUSC permutation 0b01 = FUSC permutation 0b10 = Optional FUSC permutation 0b11 = Adjacent subcarrier permutation
PUSC_UL_IDcell	7 bits	
}		
{		

3.2.2 Sub-MAP Pointer IE

Use existing H-ARQ MAP Pointer to indicate the Sub-MAP burst. The MAP Version field in the H-ARQ MAP Pointer IE is set to 01 for Sub-MAP burst.

The Pointer IE shall be appear before any other burst allocating DL-MAP IE in DL-MAP Message.

Table 283 H-ARQ MAP or Sub-MAP Pointer IE Format

Syntax	size	Note
H-ARQ and Sub- MAP Pointer IE {		
Extended DIUC	4 bits	H-ARQ MAP Pointer = 0x07
Length = 2x N	4 bits	<u>N is the number of H-ARQ MAP or Sub MAP bursts</u>
<u>While (data remains) {</u>		
AMC DIUC	4 bits	
No. Slots	8 bits	
Repetition Coding Indication	2 bits	

MAP Version	2 bits	0b00 – H-ARQ MAP v1 0b01 – Sub-MAP
CID mask included	1 bits	0 –CID mask not included 1 – CID mask included
If (CID mask included) {		
Idle users	1 bit	Bursts for Idle users included in the Sub MAP
Sleep users	1 bit	Bursts for Sleep users included in the Sub MAP
CID Mask Length	2 bits	00: 11 bits 01: 19 bits 10: 35 bits 11: 51 bits
CID mask	13 bits n bits	n = The number of bits of CID mask is determined by CID Mask Length. When the MAP message pointed by this pointer IE includes any MAP IE for an awake mode MSS, the ((Basic CID of the MSS) MOD n 13)-the LSB of CID mask shall be set to 1. Otherwise, it shall may be set to 0.
}		
}		
}		

[Modify section 10.4, p. 274, line 37-60, text in Table 343 as shown below:]

Table 343 CIDs

CID	Value	Description
Initial Ranging	0x0000	Used by SS and BS during initial ranging process.
Basic CID	0x0001 – m	The same value is assigned to both the DL and UL connection.
Primary management	m+1 – 2m	The same value is assigned to both the DL and UL connection.
Transport CIDs, Secondary Mgt CIDs	2m+1 – 0xFE9F	For the secondary management connection, the same value is assigned to both the DL and UL connection.
Multicast CIDs	0xFEAA0 – 0xFEFE	For the downlink multicast service, the same value is assigned to all MSSs on the same channel that participate in this connection.
AAS initial ranging CID	0xFEFF	A BS supporting AAS shall use this CID when allocating a Initial Ranging period for AAS devices.
Multicast polling CIDs	0xFF00 – 0xFFFFDA	A BS may be included in one or more multicast polling groups for the purposes of obtaining bandwidth via polling. These connections have no associated service flow.
Normal mode multicast CID	0xFFFFB	Used for transmission of DL broadcast information to normal mode MSS.
Sleep mode multicast CID	0xFFFFC	Used for transmission of DL broadcast information to Sleep mode MSS.
Idle mode multicast CID	0xFFFFD	Used for transmission of DL broadcast information to Idle mode MSS.
Padding CID	0xFFFFE	Used for transmission of padding information by SS and BS.
Broadcast CID	0xFFFFF	Used for broadcast information that is transmitted on a downlink to all SS.

3.2.3

3.2.3 UL MAP Fast tracking IE

[Section 8.4.5.4.21, Modify table 298h as follows]

<u>Syntax</u>	<u>Size</u>	<u>Notes</u>
<u>UL_MAP Fast tracking IE() {</u>		
<u> Extended UIUC</u>	<u>4 bits</u>	<u>Fast-Indication = 0x03</u>
<u> Number of Length</u>	<u>4 bits</u>	<u>Variable</u>
<u> Map Index</u>	<u>2 bits</u>	<u>Index of SUB-DL-UL-MAP to which this IE refers, or zero if this IE refers to the mandatory UL-MAP.</u>
<u> Reserved</u>	<u>6 bits</u>	<u>Shall be set to zero.</u>
<u> for (i = 1; i <= n; I++) {</u>		<u>For each Fast Indication bytes 1 to n (n=Length-1)</u>
<u> Power correction</u>	<u>2 bits</u>	<u>Power correction indication: 00: no change; 01: +2dB; 10: -1dB; 11: -2dB</u>
<u> Frequency correction</u>	<u>4 bits</u>	<u>The correction is 0.1% of the carrier spacing multiplied by the 4-bit number interpreted as a signed integer (i.e. 1000: -8; ... 0000: 0; ... 0111: 7)</u>
<u> Time correction</u>	<u>2 bits</u>	<u>The correction is floor(2 / Fs) multiplied by: 00: 0; 01: 1; 10: -1; 11: Not used</u>
<u> }</u>		
<u>}</u>		

[Add the follow Section 8.4.5.3.20]8.4.5.3.20 Skip IE

This IE is sent by BS in the mandatory DL-MAP as a broadcast IE. This IE is used to indicate to mobility enabled MSS (negotiated through capability exchange in REG_REQ/RSP, defined in 11.7.13.1) whether to process subsequent IEs following the Skip_IE. There are two modes of operation. At the beginning of each DL-MAP, the processing of IEs is always enabled. When a Skip_IE is encountered, and if Mode is set to 1, the mobility enabled MSS may skip the processing of all subsequent IEs in the DL-MAP. However, when a Skip_IE with Mode set to 0 is encountered, the mobility enabled MSS may disable the processing of subsequent IEs until the next Skip_IE is encountered in the DL-MAP. When the next Skip_IE with Mode set to 0 is encountered, the MSS shall enable the processing of subsequent IEs. This process continues until the end of the DL-MAP.

Table 286 Skip IE Format

<u>Syntax</u>	<u>Size</u>	<u>Notes</u>
<u>Skip_IE() {</u>		
<u> Extended DIUC</u>	<u>4 bits</u>	<u>?</u>
<u> Length</u>	<u>4 bits</u>	
<u> Mode</u>	<u>1 bit</u>	<u>If set to 1, the MSS can skip the processing of all subsequent IEs in the DL-MAP</u> <u>If set to 0, the MSS toggle the enabling and disabling of processing of IEs following the Skip_IE, until the next Skip_IE is encountered.</u>
<u> Reserved</u>	<u>7 bits</u>	

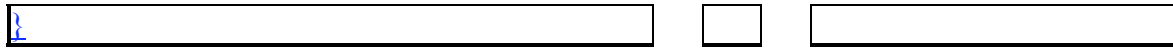

3.3 Capability Negotiation

3.3.1 MAP Capability

11.8.3.7.8 OFDMA MAP Capability

This field indicates the different MAP options supported by a WirelessMAN-OFDMA PHY. This field is not used for other PHY specifications. A bit value of 0 indicates "not supported" while 1 indicates "supported." [Support for Extended HARQ IE in Normal MAP mandates a support for Sub MAP.](#)

Type	Length	Value	Scope
155	1	bit #0: H-ARQ MAP Capability bit #1-7: reserved bit #1: Extended HARQ IE in Normal MAP capability bit #2: Sub MAP capability bit #3-7: reserved	SBC-REQ (see 6.3.2.3.23) SBC-RSP (see 6.3.2.3.24)

3.3.2 H-ARQ Burst and Buffer Capability

[Add the following text to section 11.8.3.7.12]

11.8.3.7.12 Maximum number of burst per frame capability in H-ARQ

The maximal number of uplink data burst allocations for the SS in a single UL subframe (note this number is limited to 1 in case H-ARQ is disabled)

Type	Length	Value	Scope
159	1	Maximum number of burst per HARQ enabled SS in one UL sub frame. 0 = unlimited (default)	SBC-REQ (see 6.3.2.3.23) SBC-RSP (see 6.3.2.3.24)

[Add the following text to section 11.7.8]

11.8.3.7.13 HARQ buffer capability

[Downlink/Uplink H-ARQ buffering capability indicates the maximal number of data bits the SS is able to store for downlink/uplink H-ARQ. The buffering capability is separately indicated for \$N_{ep}/N_{sch}\$ based incremental redundancy used for CTC, and for DIUC/duration based H-ARQ methods \(Chase combining and CC-IR\), and separately for uplink and downlink transmissions. The buffering capability is indicated by two parameters:](#)

1. [Number of bits per channel – this is the total number of data bits that the SS may buffer per H-ARQ channel.](#)

2. Aggregation flag – when this flag is clear, the number of bits is counted separately for each channel. When the flag is set, buffering capability may be shared between channels, as explained below.

The number of bits per channel is indicated as follows:

1. For incremental redundancy CTC (N_{EP} based): Number of bits is indicated by N_{EP} code, according to table 330.
2. For Chase combining and CC-IR (DIUC based): Number of bits is indicated by a value K=0..63 according to the following equation: $Number\ of\ bits = \text{floor}(512 \cdot 2^{K/4})$ Bits.

When aggregation flag is clear, the number of bits that were allocated in each H-ARQ channel in the last transmission must not exceed "Number of bits per channel".

When aggregation flag is set, the sum over all H-ARQ channels, of the number of bits that were allocated in the H-ARQ channel in the last transmission, must not exceed the "Number of bits per channel" multiplied by the maximum number channels supported by the SS. Note that sum total of the data bits supported is the same in both cases is the same. The number of channels supported by the SS is indicated in 11.8.3.7.3.

11.8.3.7.13.1 HARQ Incremental redundancy buffer capability

<u>Type</u>	<u>Length</u>	<u>Value</u>	<u>Scope</u>
<u>160</u>	<u>2±</u>	<u>Bits 0-3: N_{EP} value indicating downlink H-ARQ buffering capability for incremental redundancy CTC.</u> <u>Bits 4: Aggregation Flag for DL</u> <u>Bits 5-7: Reserved</u> <u>Bits 48-711: N_{EP} value indicating uplink H-ARQ buffering capability for incremental redundancy CTC.</u> <u>Bit 12: Aggregation Flag for UL</u> <u>Bits13- 15: Reserved</u>	<u>SBC-REQ</u> <u>SBC-RSP</u>

11.8.3.7.13.2 HARQ Chase combining and CC-IR buffer capability

<u>Type</u>	<u>Length</u>	<u>Value</u>	<u>Scope</u>
<u>161</u>	<u>2</u>	<u>Bits 0-5: Downlink H-ARQ buffering capability for chase combining (K).</u> <u>Bits 6: Aggregation Flag for DL</u> <u>Bits 6-7: reserved.</u> <u>Bits 8-13: Uplink H-ARQ buffering capability for chase combining (K).</u> <u>Bits 14: Aggregation Flag for UL</u> <u>Bit s14-15: reserved</u>	<u>SBC-REQ</u> <u>SBC-RSP</u>

11.8.3.7.13 — HARQ buffer capability

Downlink/Uplink H-ARQ buffering capability indicates the maximal number of data bits the SS is able to store for downlink/uplink H-ARQ over all channels. The sum over all H-ARQ channels, of the number of bits that

were transmitted in the H-ARQ channel by the BS in the last transmission, must not exceed the downlink H-ARQ buffering capability. The sum over all H-ARQ channels, of the number of bits that were allocated to the SS in the H-ARQ channel in the last transmission, must not exceed the uplink H-ARQ buffering capability. The BS may use the uplink H-ARQ buffering capability to correctly schedule allocation of H-ARQ channels to the SS. The buffering capability is indicated by a number $K=0..63$ which indicates buffering capability of

$$N = \text{floor}(512 \cdot 2^{K/4}) \text{ Bits.}$$

Buffering capability is defined separately for IR and for Chase, and separately for uplink and downlink.

11.8.3.7.13.1 HARQ Incremental redundancy buffer capability

Type	Length	Value	Scope
<u>160</u>	<u>21</u>	<p><u>Bits 0-54: Downlink H-ARQ buffering capability for incremental redundancy.</u> <u>Bits 6-7: reserved.</u> <u>Bits 8-13: Uplink H-ARQ buffering capability for incremental redundancy.</u> <u>Bits 14-15: reserved</u></p> <p>The maximal number of data bits the SS is able to store for H-ARQ. The sum over all H-ARQ channels, of the number of bits that were transmitted in the H-ARQ channel by the BS in the last transmission, must not exceed this number.</p> <p>The downlink buffering capability is indicated by a number $K=0..15$ which indicates buffering capability of</p> $N = \text{floor}(512 \cdot 2^{(K/2)}) \text{ Bits.}$ <p>Bits 5-7 reserved.</p>	<p><u>SBC-REQ</u> <u>SBC-RSP</u></p>

11.8.3.7.13.2 HARQ Chase combining buffer capability

Type	Length	Value	Scope
<u>160</u>	<u>2</u>	<p><u>Bits 0-5: Downlink H-ARQ buffering capability for chase combining.</u> <u>Bits 6-7: reserved.</u> <u>Bits 8-13: Uplink H-ARQ buffering capability for chase combining.</u> <u>Bits 14-15: reserved</u></p>	<p><u>SBC-REQ</u> <u>SBC-RSP</u></p>

Type	Length	Value	Scope
<u>160</u>	<u>2</u>	<p>Bits 0-5: Downlink H-ARQ buffering capability. Bits 6-7: reserved. Bits 8-13: Uplink H-ARQ buffering</p>	<p>SBC-REQ SBC-RSP</p>

		capability Bits 14-15: reserved	
--	--	------------------------------------	--

Downlink/Uplink H-ARQ buffering capability indicates the maximal number of data bits the SS is able to store for downlink/uplink H-ARQ over all channels. The sum over all H-ARQ channels, of the number of bits that were transmitted in the H-ARQ channel by the BS in the last transmission, must not exceed the downlink H-ARQ buffering capability. The sum over all H-ARQ channels, of the number of bits that were allocated to the SS in the H-ARQ channel in the last transmission, must not exceed the uplink H-ARQ buffering capability. The BS may use the uplink H-ARQ buffering capability to correctly schedule allocation of H-ARQ channels to the SS. The buffering capability is indicated by a number $K=0..63$ which indicates buffering capability of

$$N = \text{floor}(512 - 2^{K/4}) \text{ Bits.}$$

11.8.3.7.2 OFDMA MSS demodulator

[Apply the following change to the table:]

Type	Length	Value	Scope
151	\pm Variable	Bit #0: 64-QAM Bit #1: BTC Bit #2: CTC Bit #3: STC Bit #4: AAS Diversity Map Scan Bit #5: AAS Direct Signaling H-ARQ Chase CC Bit #6: H-ARQ CTC IR Bit #7: H-ARQ with SPID=0 only Bit #8: H-ARQ CC IR Bit #9-15 - reserved	SBC-REQ (see 6.3.2.3.23) SBC-RSP (see 6.3.2.3.24)

When the length of this TLV is 1 byte it indicates bits 8-15 are zero.

11.8.3.7.3 OFDMA MSS demodulator

[Apply the following change to the table:]

Type	Length	Value	Scope
152	\pm Variable	Bit #0: 64-QAM Bit #1: BTC Bit #2: CTC Bit #3: STC Bit #4: AAS Diversity Map Scan Bit #5: AAS Direct Signaling H-ARQ Chase CC Bit #6: H-ARQ CTC IR Bit #7: H-ARQ with SPID=0 only Bit #8: H-ARQ CC IR Bit #9-15 - reserved	SBC-REQ (see 6.3.2.3.23) SBC-RSP (see 6.3.2.3.24)
153	1	The Number of H-ARQ ACK channel	SBC-REQ (see 6.3.2.3.23) SBC-RSP (see 6.3.2.3.24)

When the length of TLV 152 is 1 byte it indicates bits 8-15 are zero.

3.4 MAC implications of H-ARQ operation

3.4.1 Changes overview

General description

~~The mechanisms described herein lead to a natural improvement to the ARQ mechanisms, in the form of Fast ARQ. It is possible to use the proposed combination of MAC ARQ functionality with H-ARQ functionality, even when the PHY does not support H-ARQ. MAC ARQ is used as described above for sequencing, re-ordering, time-keeping and synchronization.~~

~~3.4.1.1 MAC ARQ Mode for H-ARQ~~

~~Using the standard MAC ARQ mechanism over H-ARQ presents some problems. The MAC ARQ itself generates feedbacks, which are costly in bandwidth. Additionally, it is not necessarily the case that an operator will want to enable MAC ARQ, for example in UGS connections. It should be noted that UGS connections are not compatible with MAC ARQ since there is no way to allocate bandwidth for MAC ARQ retransmissions or feedbacks. The proposal of this document is to define a new 802.16 ARQ mode for support of H-ARQ. Under this mode, all regular MAC ARQ parameters are defined, e.g. BLOCK_LIFETIME, WINDOW_SIZE, SYNC_LOSS_TIMEOUT, etc. However, the receiver MAC under this mode shall not generate MAC ARQ feedbacks. Rather, it is the responsibility of the underlying H-ARQ mechanism to send and receive H-ARQ ACK signaling. The proposal of this document is that the transmitter PHY will generate ARQ Feedback messages for its own transmitter MAC layer and thus allow integration of these two mechanisms. In other words, the transmitter H-ARQ receives H-ARQ ACK signals from the receiver H-ARQ. The transmitter H-ARQ shall convert these H-ARQ ACK signals into MAC ARQ feedbacks and pass them to the transmitter MAC ARQ, on the same machine. Thus, both H-ARQ and MAC ARQ can coexist, without the need to send ACK signals at both levels; the H-ARQ ACK signaling suffices.~~

~~To sum, H-ARQ provides retransmissions and ACK signaling. MAC ARQ provides sequencing, reordering, time-keeping for PDUs and synchronization between the receiver and transmitter ARQs.~~

3.4.1.1 Replay Attack Windowing

A standard mechanism in 802.16 security is replay attack protection. This is achieved by discarding any packet with a Packet Number (PN) which is lower than the highest received PN for a certain Security Association (SA). This mechanism assumes reception of PDUs at the MAC in order from the PHY. This assumption is not valid if H-ARQ is used for this CID, since H-ARQ transmits PDUs from a single CID over a number of H-ARQ channels without committing to the order at the receiver. Therefore, if a PDU is received incorrectly, H-ARQ will retransmit on this particular H-ARQ channel while receiving normally on all the other H-ARQ channels. This single PDU will be received out of order for example.

In order to prevent replay attacks even when PDU order is not guaranteed, the mechanism should be extended as follows. The receiver shall maintain a PN window for each SA. Any PDU received with a PN which is less than the beginning of the window shall be discarded as a replay attempt. Additionally, the receiver shall track which PNs have been received within the PN window. If a PDU is received with a PN that has already been received, it shall be discarded as a replay attempt. Reception of PNs which are greater than the highest received PN for an SA shall advance the PN window forward to cover this newly received PN.

3.4.2 Specific text changes to the Standard

~~*[Change in section 6.3.4.6.3]*~~
~~*[add to end of section]*~~

~~If H-ARQ is enabled for a connection, it is possible for the receiver not to generate ARQ Feedback messages. Instead, the transmitter PHY shall use HARQ signaling to emulate ARQ Feedback indications. See section 6.3.17.6~~

~~*[Change in section 6.3.17]*~~
~~*[add to end of section]*~~

~~H-ARQ is enabled on a CID basis. An H-ARQ enabled CID must have ARQ enabled as well for this CID. See section 6.3.17.6~~

~~*[Insert new section 6.3.17.6]*~~

~~**H-ARQ and MAC-ARQ Interaction**~~

~~H-ARQ enabled connections shall have regular ARQ (MAC-ARQ) enabled for them as well. However, since acknowledgement signaling is taken care of at the H-ARQ level, the receiver MAC may not generate ARQ Feedback Messages for acknowledgment. Instead, the transmitter PHY may emulate ARQ Feedback Messages, according to the H-ARQ acknowledgements received, and shall forward these ARQ Feedbacks to the transmitter MAC. ARQ Discard and ARQ Reset messages shall be transmitted normally.~~

~~The ARQ state machines shall be aware that a certain connection is H-ARQ enabled and may configure not to generate ARQ Feedback Messages in this case.~~

~~*[Change in section 7.5.1.2.4]*~~
~~*[add to end of section]*~~

~~The receiver shall maintain a PN window whose size is specified by the PN_WINDOW_SIZE parameter per SA as defined in 11.9.36. Any received PDU with a PN lower than the beginning of the PN window shall be discarded as a replay attempt. The receiver shall track PNs within the PN window. Any PN that is received more than once shall be discarded as a replay attempt. Upon reception of a PN which is greater than the end of the PN window, the PN window shall be advanced to cover this PN~~

~~*[Insert new section 11.18.6]*~~

~~**11.8.6 PN Window Size**~~

~~Specifies the size capability of the receiver PN window per SAID. The receiver shall track PNs within this window to prevent replay attacks (see 7.5.1.2.4).~~

<u>Type</u>	<u>Length</u>	<u>Value</u>	<u>Scope</u>
44	<u>2</u>	<u>PN Window Size in PNs</u>	<u>SBC-REQ, SBC-RSP</u>

~~*[Insert new section 11.13.18.10]*~~

~~**11.13.18.10 ARQ Feedback Generation**~~

~~Specifies whether the receiver MAC shall generate ARQ Feedback messages. It is useful in any case when the only requirement from the ARQ level is ordering rather than retransmission for example, in H-ARQ and Fast-ARQ enabled connections (see 6.3.17.6).~~

Type	Length	Value	Scope
■	1	0 = Generate ARQ Feedbacks (default) 1 = Do not generate ARQ Feedbacks	DSA-REQ, DSA-RSP, REG-REQ, REG-RSP

[Insert new section 11.13.32]

11.13.32 H-ARQ Service Flows

Specifies whether the connection uses H-ARQ or not.

Type	Length	Value	Scope
44	<u>1</u>	<u>0 = Non H-ARQ (default) 1 = H-ARQ Connection</u>	<u>DSA-REQ, DSA-RSP, REG-REQ, REG-RSP</u>

3.4.1.2 Remedy 2: Changes to include Fast ARQ

General description

Fast-ARQ is used for retransmissions and ACK signaling.

Fast-ARQ uses the same UL-ACK-channel proposed by H-ARQ. However, Fast-ARQ does not involve Chase Combining, but only regular PDU retransmissions. The information indicating the UL-ACK slot is prepended to each PDU when using Fast-ARQ. The UL-ACK slot is inserted into the PDU using the ESF field.

The benefits of Fast-ARQ over MAC-ARQ are clear: it is far less costly in bandwidth, it allows for extremely fast ARQ feedbacking using the H-ARQ defined UL-ACK channel, and it requires no bandwidth allocation for its feedbacks.

The mechanisms described herein lead to a natural improvement to the ARQ mechanisms, in the form of Fast-ARQ. It is possible to use the proposed combination of MAC-ARQ functionality with H-ARQ functionality, even when the PHY does not support H-ARQ. This can be achieved as follows:

- 1)MAC-ARQ is used as described above for sequencing, re-ordering, time-keeping and synchronization.
- 2)Fast-ARQ is used for retransmissions and ACK signaling.

Fast-ARQ uses the same UL-ACK-channel proposed by H-ARQ. However, Fast-ARQ does not involve Chase Combining, but only regular PDU retransmissions. The information indicating the UL-ACK slot is prepended to each PDU when using Fast-ARQ. The UL-ACK slot is inserted into the PDU using the ESF field.

~~The benefits of Fast-ARQ over MAC-ARQ are clear: it is far less costly in bandwidth, it allows for extremely fast ARQ feedback using the H-ARQ defined UL-ACK channel, and it requires no bandwidth allocation for its feedbacks.~~

~~3.4.1.3 Replay Attack Windowing~~

~~A standard mechanism in 802.16 security is replay attack protection. This is achieved by discarding any packet with a Packet Number (PN) which is lower than the highest received PN for a certain Security Association (SA). This mechanism assumes reception of PDUs at the MAC in order from the PHY. This assumption is not valid if H-ARQ is used for this CID, since H-ARQ transmits PDUs from a single CID over a number of H-ARQ channels without committing to the order at the receiver. Therefore, if a PDU is received incorrectly, H-ARQ will retransmit on this particular H-ARQ channel while receiving normally on all the other H-ARQ channels. This single PDU will be received out of order for example.~~

~~In order to prevent replay attacks even when PDU order is not guaranteed, the mechanism should be extended as follows. The receiver shall maintain a PN window for each SA. Any PDU received with a PN which is less than the beginning of the window shall be discarded as a replay attempt. Additionally, the receiver shall track which PNs have been received within the PN window. If a PDU is received with a PN that has already been received, it shall be discarded as a replay attempt. Reception of PNs which are greater than the highest received PN for an SA shall advance the PN window forward to cover this newly received PN.~~

~~3.4.1.4 Extended Subheader Field (ESF)~~

~~The current MAC PDU format is very limited in introducing additional information fields which need to be conveyed along with the PDU. A recent contribution has enhanced the PDU with the MSF bit indicating an additional field containing the Mode Selection Feedback subheader. This document proposes to extend this bit to allow mini-TLVs to be used within~~

~~a MAC PDU. This allows the standard to introduce new information fields easily and in a scalable way, whereas today the MSF bit and other values change the GMH header directly in a restricting and inflexible way.~~

~~The mini-TLVs are composed of a 4-bit Type field, 4-bit Length field in octets and the value itself. Thus, fields of up to 16 octets can be used. The overhead for any field is 1 octet. For example, the Mode Selection Feedback subheader will become 2 octets instead of 1 octet as it is defined today.~~

~~The MSF bit in the GMH will be overridden to become the Extended Subheader Fields (ESF) bit. If it is 1, immediately following the GMH will be the ESF octet indicating the total length of the mini-TLVs following. The ESF octet will be followed by mini-TLVs, each mini-TLV is at least 1 octet in length and up to 16 octets in length.~~

3.4.2 Specific text changes to the Standard

~~[Change in section 6.3.2.1.1]~~

~~Figure 19a~~

~~Change MSF (1) to ESF (1)~~

~~Table 5a~~

Name	Length (Bits)	Description
<remove MSF>		
ESF	1	Extended Subheader Field. If ESF =

		<p>0, the ESF is absent. If ESF=1, the ESF is present and will follow the GMH immediately. (See section 6.3.2.2.7). An MSS shall set this bit to 1 only if it has successfully negotiated the support of ESF with the BS through the capabilities exchange dialog (SBC-REQ/RSP).</p>
--	--	---

~~[Change in section 6.3.2.2]~~

~~[Modify the following sentences]~~

~~FiveFiveSix types of subheaders may be present in a MAC PDU with generic MAC header. The per-PDU subheaders (i.e., Mode Selection Feedback, Mesh, Fragmentation, FASTFEEDBACK Fast-feedback Allocation and Grant Management) may be inserted in MAC PDUs immediately following the Generic MAC header. If both the Fragmentation subheader and Grant Management subheader are indicated, the Grant Management subheader shall come first. If the Mesh subheader is indicated, it shall precede all other subheaders. In the downlink, the FAST-FEEDBACK Fast-feedback Allocation subheader shall always appear as the last per-PDU subheader, while in the uplink the Mode Selection Feedback~~

~~subheader shall always appear as the last per-PDU subheader. The Mode Selection Feedback subheader, if indicated in UL Generic MAC header, shall always appear as the last per-PDU subheader in a UL MAC PDU.~~

~~Add the following to end of section~~

~~The ESF bit in the GMH indicates that the Extended Subheader Field is present. Using this field, a number of additional subheaders can be used within a PDU. The ESF field shall always appear immediately after the GMH, and before all other subheaders. The ESF field and all subheaders related to it are not encrypted. (See section 6.3.2.2.7)~~

~~[Insert new section 11.13.32]~~

~~H-ARQ/Fast-ARQ Service Flows~~

~~Specifies whether the connection uses H-ARQ or Fast-ARQ.~~

Type	Length	Value	Scope
■	1	0 = Non H-ARQ (default) 1 = H-ARQ Connection 2 = Fast-ARQ Connection	DSA-REQ, DSA-RSP, REG-REQ, REG-RSP

~~[Add the following section 6.3.2.2.7]~~

~~6.3.2.2.7 Extended Subheader Field~~

~~The Extended Subheader Field subheader is specified in Table 13. The Extended Subheader Field, when used, shall always appear immediately after the GMH and before all other subheaders, as described in 6.3.2.2. The ESF field and all mini-TLVs related to it shall not be encrypted.~~

~~Table 13~~

Name	Length (Bits)	Description
Total length (in octets) of mini-TLVs	8	Indicates the total length of all the mini-TLVs following the ESF subheader. The length is specified in octets.

~~[Change in section 6.3.4.6.3]~~

~~[add to end of section]~~

~~If H-ARQ is enabled for a connection, it is possible for the receiver not to generate ARQ Feedback messages. Instead, the transmitter PHY shall use HARQ signaling to emulate ARQ Feedback indications. See section 6.3.17.6~~

~~[Change in section 6.3.17]~~

~~*[add to end of section]*~~

~~H-ARQ is enabled on a CID basis. An H-ARQ enabled CID must have ARQ enabled as well for this CID. See section 6.3.17.6~~

~~*[Insert new section 6.3.17.6]*~~

~~6.3.17.6 H-ARQ and MAC-ARQ Interaction~~

~~H-ARQ enabled connections shall have regular ARQ (MAC-ARQ) enabled for them as well. However, since acknowledgement signaling is taken care of at the H-ARQ level, the receiver MAC shall may not generate ARQ Feedback Messages for acknowledgment. Instead, the transmitter PHY shall may emulate ARQ Feedback Messages, according to the H-ARQ acknowledgements received, and shall forward these ARQ Feedbacks to the transmitter MAC. ARQ Discard and ARQ Reset messages shall be transmitted normally.~~

~~The ARQ state machines shall be aware that a certain connection is H-ARQ enabled and shall may configure not to generate ARQ Feedback Messages in this case, using.~~

~~*[Insert new section 6.3.17.7]*~~

~~6.3.17.7 Fast-ARQ~~

~~Fast-ARQ is a form of ARQ whereby retransmissions and acknowledgements are handled much like in H-ARQ, using an ACK channel. However, in Fast-~~

~~ARQ the PHY takes no part in reconstructing the data like in IR or Chase Combining. Rather, retransmissions are done on whole PDUs much like in regular ARQ.~~

~~This allows for fast acknowledgements and retransmissions, without necessitating to slow mechanisms like Bandwidth Requests.~~

~~Fast-ARQ enabled connections shall use a UL-ACK channel defined for H-ARQ. Every PDU transmitted in the DL shall indicate the ACK slot that shall be used for acknowledging it; this information shall be pre-pended to the PDU using the ESF subheader. As defined in 6.3.17.6, Fast-ARQ enabled connections shall have ARQ enabled for them as well. However, the regular ARQ mechanism shall not generate ARQ Feedback messages. The transmitter Fast-ARQ shall emulate ARQ Feedbacks for its own transmitter MAC based on the ACK indications received in the ACK channels.~~

~~*[Change in section 7.5.1.2.4]*~~

~~*[add to end of section]*~~

~~The receiver shall maintain a PN window whose size is specified by the PN_WINDOW_SIZE parameter per SA as defined in 11.9.36. Any received PDU with a PN lower than the beginning of the PN window shall be discarded as a replay attempt. The receiver shall track PNs within the PN window. Any PN that is received more than once shall be discarded as a replay attempt. Upon reception of a PN which is greater than the end of the PN window, the PN window shall be advanced to cover this PN~~

~~*[Change in section 11.8.2]*~~

~~11.8.2 Capabilities for Construction and Transmission of MAC PDUs~~

Type	Length	Value	Scope
4	1	<p>Bit #2: Specifies support for ESF capability (see 6.3.2.2.7)</p> <p>Bit #3-#7: Reserved, shall be set to zero</p>	SBC-REQ, SBC-RSP

~~[Insert new section 11.18.6]~~

~~11.8.6 PN Window Size~~

~~Specifies the size capability of the receiver PN window per SAID. The receiver shall track PNs within this window to prevent replay attacks (see 7.5.1.2.4).~~

Type	Length	Value	Scope
■	2	PN Window Size in PNs	SBC-REQ, SBC-RSP

~~[Insert new section 11.13.18.10]~~

~~11.13.18.10 ARQ Feedback Generation~~

~~Specifies whether the receiver MAC shall generate ARQ Feedback messages. It is useful in any case when the only requirement from the ARQ level is ordering rather than retransmission. For example, in For H-ARQ or and Fast-ARQ enabled connections, even though ARQ is used, ARQ Feedback messages may be disabled (see 6.3.17.6).~~

Type	Length	Value	Scope
■	1	<p>0 = Generate ARQ Feedbacks (default)</p> <p>1 = Do not generate ARQ Feedbacks (H-ARQ/ Fast-ARQ)</p>	<p>DSA-REQ, DSA-RSP, REG-REQ, REG-RSP</p>

~~[Insert new section 11.13.32]~~

~~11.13.32H-ARQ/Fast-ARQ Service Flows~~

~~Specifies whether the connection uses H-ARQ or Fast-ARQ.~~

Type	Length	Value	Scope
------	--------	-------	-------

Type	Length	Value	Scope
■	1	0 = Non H-ARQ 1 = H-ARQ Connection 2 = Fast-ARQ Connection	DSA-REQ, DSA-RSP, REG-REQ, REG-RSP

[Insert new section 11.20]

11.20 Mini-TLV Encodings

~~The format of mini-TLVs is specified in Table 11.20.1. Mini-TLVs are used with the Extended Subheader Field (see section 6.3.2.2.7). The list of defined mini-TLVs is given in Table 11.20.2.~~

~~Table 11.20.1~~

Name	Length (Bits)	Description
Type	4	Mini-TLV Type (0-15)
Length	4	Mini-TLV Length in octets (0-15 octets) not including the Type and Length fields
Value	<Indicated by the Length field in	The Mini-TLV Value

	octets>	
--	-------------------	--

~~Table 11.20.2~~^[e5]UL

Type	Name	Length (Octets)	Description
0b0000	<i>Reserved</i>		<i>Reserved</i>
0b0001	Mode Selection Feedback	1	See 11.20.1
0b0010	UL-ACK Slot Indication	1	See 11.20.2
0b0011-0b1111	<i>Reserved</i>		<i>Reserved</i>

DL

Type	Name	Length (Octets)	Description
0b0000-0b1111	<i>Reserved</i>		<i>Reserved</i>

~~[Insert new section 11.20.1]~~~~11.20.1 Mode Selection Feedback mini-TLV~~

<move section 6.3.2.2.7 here>

~~[Insert new section 11.20.2]~~

~~11.20.2 H-ARQ ACK half sub-channel offset~~

~~The H-ARQ ACK half sub-channel offset indication is used in Fast-ARQ enabled connections. For each PDU in the DL, the BS shall indicate in the extended subheader (ESF) the parameters for the ACK slot to be used in the UL H-ARQ ACK Channel. The format of this mini-TLV is specified in Table x.x.x.~~

~~Table x.x.x~~

Name	Length (Octets)	Description
H-ARQ ACK half sub-channel offset	1	Absolute value of the half subchannel offset in the HARQ ACK channel in which an acknowledgment should be transmitted for this PDU.