

2003-05-29

IEEE 802.16e-03/07r2

~~Draft Amendment to IEEE Standard for
Local and Metropolitan Area Networks~~

Part 16: Air Interface for Broadband Wireless Access Systems - Amendment 4: Mobility Enhancements

Sponsor
LAN MAN Standards Committee
of the
IEEE Computer Society
and the
IEEE Microwave Theory and Techniques Society



Abstract: This Amendment updates and expands IEEE Std 802.16-2001 to allow for mobility.

Keywords: WirelessMAN™ standards, metropolitan area network, broadband wireless access network, millimeter waves, microwaves, mobility

This page intentionally left blank.

Contents

6.2.2.3.37 Mesh Centralized Scheduling (MSH-CSCH) message.....	1
6.2.5.1 Unsolicited Grant Service.....	1
6.2.5.2 Real-Time Polling service.....	1
6.2.5.3 Non-Real-Time Polling service.....	2
6.2.13.2 Service flows.....	2
6.2.13.8.4 Dynamic Service Change (DSC).....	2
8.4.2.2 Derived parameter definitions.....	3
8.4.2.4 Parameters of transmitted signal.....	3
8.4.3.1 Randomization.....	3
8.4.3.2.1 Concatenated Reed-Solomon / convolutional code (RS-CC).....	3
8.4.3.3 Interleaving.....	3
8.4.3.4.1 Data modulation.....	4
8.4.3.5 Example OFDM UL RS-CC encoding.....	4
8.4.3.6 Preamble structure and modulation.....	5
8.4.4.1 PMP.....	5
8.4.5.1 DL-MAP PHY Synchronization Field.....	6
8.5.4.3 DL Frame Prefix.....	6
8.5.5.2 DL-MAP Information Element format.....	7
8.5.5.3 UL-MAP Information Element format.....	8
10.1 Global Values.....	9
11.4.1.2.7 WirelessMAN-OFDM/OFDMA FFT sizes.....	10
11.4.1.2.8 WirelessMAN-OFDM Focused Contention Support.....	10
11.4.8.11 Service flow scheduling type.....	10
11.4.8.12 Request/transmission policy.....	10
11.4.8.15 Fixed-length versus variable-length SDU indicator.....	11
11.4.8.16 SDU size.....	11
11.4.9.4.4 ATM Classifier Error Parameter Set.....	11

Figures

Tables

Table 116al—Bit interleaved block sizes.....	4
Table 116am—OFDM PHY synchronization field.....	6
Table 116an—OFDMA DL Frame Prefix.....	7
Table 116ao—OFDMA DL-MAP_Information_Element format.....	8
Table 116bp—OFDMA UL-MAP Information Element format.....	9
Table 118b—Parameters and constants.....	9

~~Draft Amendment to IEEE Standard for
Local and Metropolitan Area Networks~~

**Part 16: Air Interface for Broadband
Wireless Access Systems -
Amendment 4: Mobility Enhancements**

NOTE-The editing instructions contained in this amendment/corrigendum define how to merge the material contained herein into the existing base standard IEEE Standard 802.16-2001 and its amendments IEEE 802.16a-2003 and 802.16c-2002 to form the comprehensive standard.

The editing instructions are shown *bold italic*. Four editing instructions are used: *change*, *delete*, *insert*, and *replace*. *Change* is used to make small corrections in existing text or tables. The editing instruction specifies the location of the change and describes what is being changed by using strike through (to remove old material) and underscore (to add new material). *Delete* removes existing material. *Insert* adds new material without disturbing the existing material. Insertions may require renumbering. If so, renumbering instructions are given in the editing instruction. *Replace* is used to make large changes in existing text, subclauses, tables, or figures by removing existing material and replacing it with new material. Editorial notes will not be carried over into future editions because the changes will be incorporated into the base standard.

1
2
3
4
5
6
7
8
9
10
11
12
13
14
15
16
17
18
19
20
21
22
23
24
25
26
27
28
29
30
31
32
33
34
35
36
37
38
39
40
41
42
43
44
45
46
47
48
49
50
51
52
53
54
55
56
57
58
59
60
61
62
63
64
65

Change section title to the following:

[Section 1.3 of P802.16/D7-2002]

1.3 Baseline Reference Model

[Insert the following text into Section 1.3.1 of P802.16/D7-2002 .]

1.3.1 Network Model for Mobile Communications

1.3.1.1 Network reference model

1.3.1.1.1 Entities

The network reference model consists of BS units covering a certain area, and connected by a backbone network. Several such networks, owned by different operators may coexist in the same service area. Each backbone network may contain centralized AAA (Authorization, Authentication and Accounting), management, provisioning or other specialized servers. Specifically, those servers responsible for authentication and service authorization are collectively referred to as ASA-server(s) and may be single, multiple, centralized or distributed. The operation of these servers with the BS and MSS is specified to the extent of defining the control messages.

Table 0b1—Mobility Related Entities

Reference Point	Elements to be Specified by 802.16E
MSS	Mobile Subscriber Station, contains MAC (CS), PHY layers
BS	Base Station Sector: a single MAC entity covers a single sector. BS, at the network side, supports functionality similar to Foreign Agent of Mobile IP working in "foreign agent care-of address" mode.
ASA Server(s)	Authentication and Service Authorization Server servicing the whole operator's network. These servers are optional, and may be implemented as a distributed entity.

Figure 0b1 shows an example of such a network, where two networks operated by different operators coexist in the same service area. BS #1 is the serving BS for the depicted MSS. BS #2 and BS #3 are neighbor BS. Should the depicted MSS move closer to BS #2, as drawn by dotted line BS #2 might be the target BS for an HO. Should the depicted MSS continue movement

Figure 0b1—Network Model Example

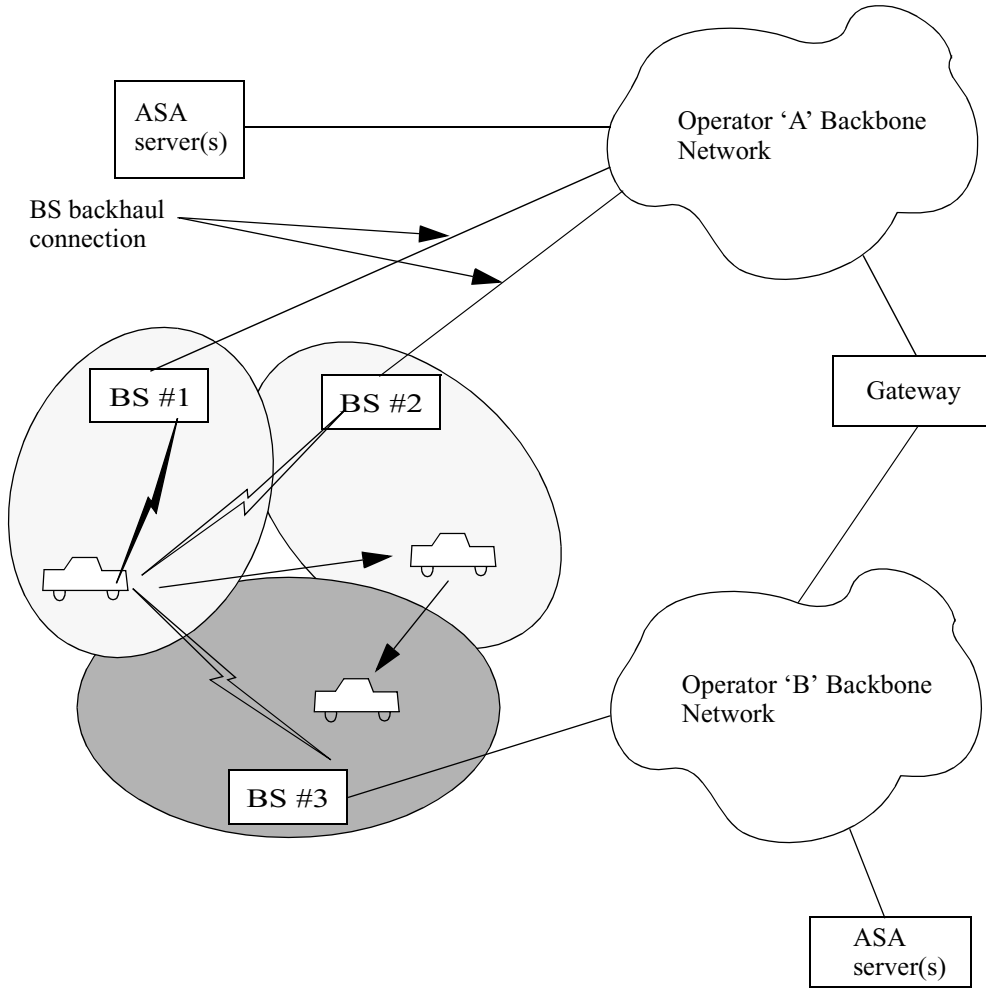
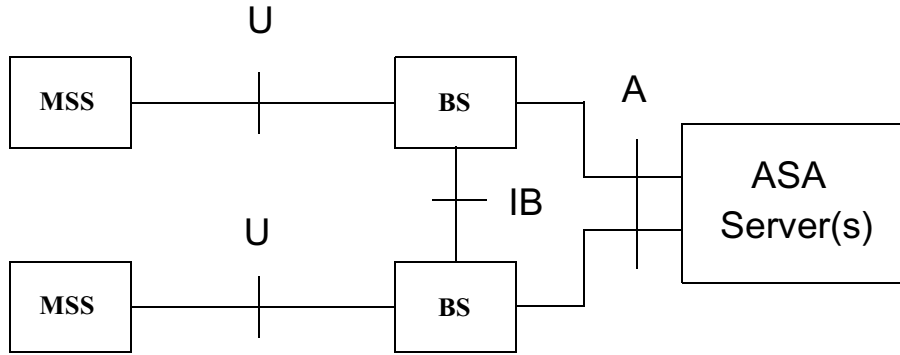

Figure 0b2 shows the network reference model in the control plane.

1
2
3
4
5
6
7
8
9
10
11
12
13
14
15
16
17
18
19
20
21
22
23
24
25
26
27
28
29
30
31
32
33
34
35
36
37
38
39
40
41
42
43
44
45
46
47
48
49
50
51
52
53
54
55
56
57
58
59
60
61
62
63
64
65

Figure 0b2—Network Reference Model, Control Plane



The following reference points are present at the control plane network model

Table 0b2—Reference Points at Control Plane

Reference Point	Elements to be Specified by 802.16E	Comments
U	PHY, MAC (including CS) operations, Mobility Sub-layer messages exchange	
IB	BS-to-BS messages	Transport protocol is not specified
A	Messages serving MSS authentication and service authorization functions	Transport protocol is not specified

Note: In the case a BS is implemented as a set of BS controlled by a single central controller, IB reference point is located in the controller. This makes inter-cell and intra-cell HO indistinguishable.

1
2
3
4
5
6
7
8
9
10
11
12
13
14
15
16
17
18
19
20
21
22
23
24
25
26
27
28
29
30
31
32
33
34
35
36
37
38
39
40
41
42
43
44
45
46
47
48
49
50
51
52
53
54
55
56
57
58
59
60
61
62
63
64
65

1.3.1.1.2 MSS Protocol Stack

No difference here compared to IEEE 802.16a standard.

1.3.1.1.3 BS Protocol Stack

The following picture displays BS protocol stack

Figure 0b3—BS Protocol Stack

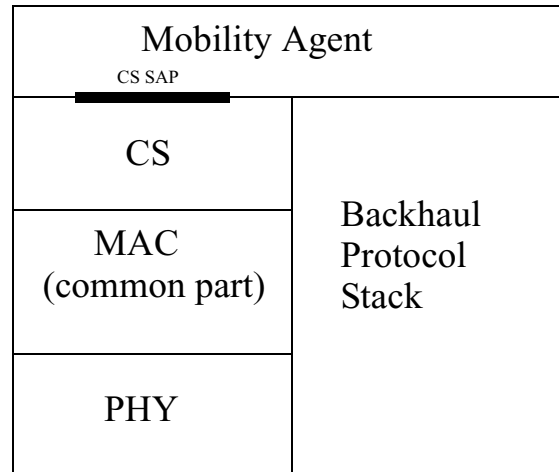

1.3.1.1.3.1 Mobility Agent (MA) Operations

In addition to regular 802.16 layers, the stack contains Mobility Agent (MA) layer. The functions of MA are similar to functions of Foreign Agent of Mobile IP working in "foreign agent care-of address" mode. Nevertheless, we avoid direct specification of Mobile IP as a protocol that implements mobility features from the backbone side.

MA provides the following functions,

- Termination of tunnel carrying data from MSS home network including de-capsulation of incoming data units

- Communication to CS about:

- After arrival of new MSS to the cell, creation of new connections. This includes

- Creation of new classifier(s) to forward data to the connections

- Specification of proper QoS per connection

- After MS departure, deletion of connections and classifiers

1.3.1.1.4 MSS Service Context

Network Service is defined as a service provided to the MSS by the network through a single MAC connection with particular connectivity and MAC parameters (including QoS properties). Connectivity properties are defined by specification of MSS network address in its Home Network.

MSS Service Context specifies the set of network services authorized for a given MSS. It is composed of the following elements:

Table 0b3—MSS Service Context

Context Element	Meaning
MSS 48-bit MAC address unique identifier	48-bit unique identifier used by MSS on initial network. This ID does not change while MSS passes from one BS to another. During HO it is used to refer to specific connectivity (addressing) and properties of MAC connections (including QoS properties)
Number N of Network Service IEs	Number of Network Service Information Elements (NSIEs). Each SIE corresponds to a single data connection
N x NSIE	The structure of SIE is specified below
Number M of Security Association	Number M of Security Associations established for the MSS.
M x SAIE	TBD

Table 0b4—Service Information Element(SIE) Contents

Field	Meaning
Address of MSS at Home Network	IP address of MSS at its Home Network. This address does not change while MSS travels from one BS to another. [?]
MAC Connection Parameters	Connection parameters as specified in , section 6.1.1.1.2

Figure 0b4—Network Structure (control plane) and HO

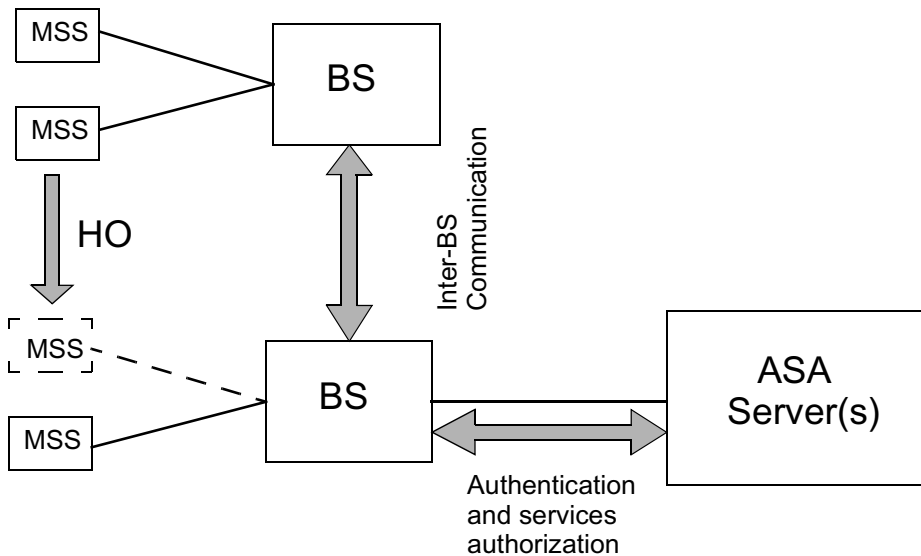

1
2
3
4
5
6
7
8
9
10
11
12
13
14
15
16
17
18
19
20
21
22
23
24
25
26
27
28
29
30
31
32
33
34
35
36
37
38
39
40
41
42
43
44
45
46
47
48
49
50
51
52
53
54
55
56
57
58
59
60
61
62
63
64
65

1.3.1.1.5 Transfer of Control Information During HO

Figure 0b5—Network Structure (data plane) and HO

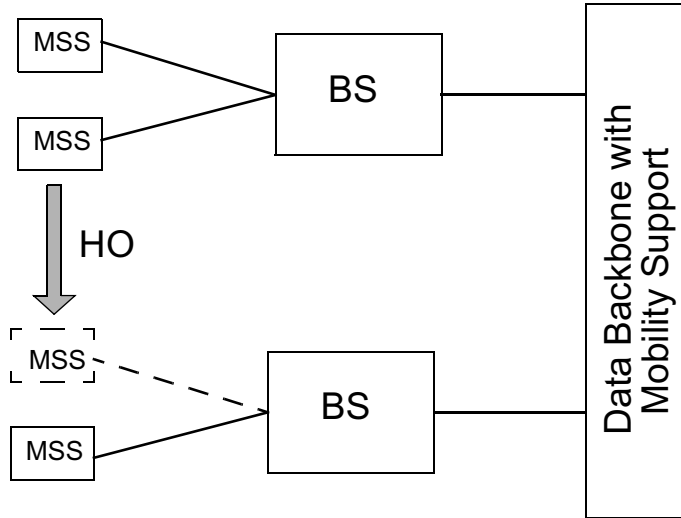

1.3.1.2 MAC layer HO procedures

This section contains the procedures performed during HO on the air-interface.

1.3.1.2.1 Network topology acquisition

1.3.1.2.1.1 Network topology advertisement

A BS shall broadcast information about the network topology using the NBR-ADV MAC message. An MSS may decode this message to find out information about the parameters of neighbor BS. Each MSS will thus be able to synchronize quickly with neighbor BS.

1.3.1.2.1.2 MSS Scanning of neighbor BS

A BS may allocate time intervals to MSS's for the purpose of seeking and monitoring neighbor BS suitability as targets for HO. Such a time interval will be referred to as a **scanning interval**.

An MSS may request an allocation of a scanning interval using the SCN-REQ MAC message. The MSS indicates in this message the duration of time it requires for the scan, based on its PHY capabilities.

Upon reception of this message, the BS shall respond with placement of a Scanning_IE in the DL-MAP. The Scanning_IE shall either grant the requesting MSS a scanning interval that is at least as long as requested by that MSS, or deny the request. The BS may also place unsolicited Scanning_IE.

An MSS, upon detection of a Scanning_IE addressed to it in the DL-MAP, shall use the allocated interval to seek for neighbor BS. When neighbor BS are identified, the MSS shall attempt to synchronize with their downlink transmissions, and estimate the quality of the PHY connection.

1.3.1.2.1.3 Association Procedure

An MSS may use this interval for ranging as well as for the association procedure. When associating with a neighbor BS, the MSS shall not only synchronize with neighbor BS downlink, but shall also perform two additional stages called **association-initial-ranging** and **association-pre-registration**. Association-initial-ranging is performed by transmitting a RNG-REQ MAC message as specified in IEEE Std 802.16-2001 “Part 16: Air Interface for Fixed Broadband Wireless Access Systems” section 6.2.9.5 with the extensions specified in section Ranging Request/Response RNG-REQ/RSP. Upon reception of a RNG-RSP message with the **prediction of service level** parameter set to 2, the MSS marks the target BS as Associated. Information on Association is reported to the Serving BS. The target BS may store information on newly associated MSS. Association state of specific MSS at the BS shall be aged-out after ASC-AGING-TIMER timeout.

1.3.1.2.2 HO process

The section defines the HO process in which an MSS migrates from the air-interface provided by one BS to the air-interface provided by another BS. The HO process belongs to the break-before-make type and consists of the following stages:

HO initiation, the decision to start the process is taken

Termination of service with the serving BS, where all connections belonging to the MSS are terminated, and the context associated with them (i.e. information in queues, ARQ state-machine, counters, timers, etc.) is discarded

Network re-entry in target BS, where the MSS re-enters the network using a fast network entry procedure. After network re-entry, connection belonging to the MSS are re-established based on the availability of resources in the target BS.

The HO process, and its similarity to the initial network entry process, is depicted in Figure 0b6.

Figure 0b6—HO and Initial Network Entry

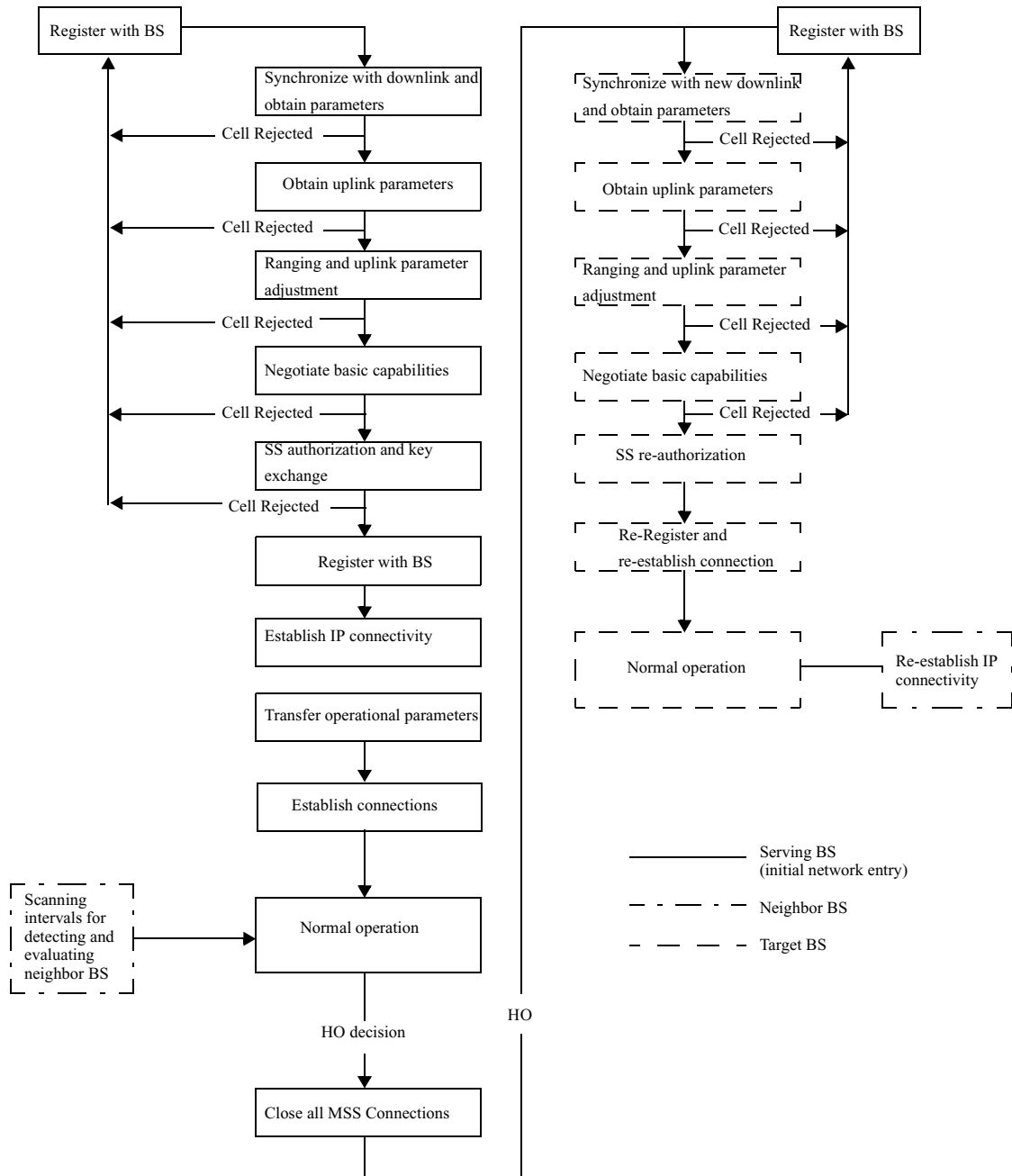

1.3.1.2.2.1 Cell Selection

Cell selection is a terminology use to refer to situations where an MSS leaves a BS before getting to the normal-operation state. Such procedure does not involve termination of existing connections and their re-opening in the target BS. An MSS may perform a cell selection if such an action is necessary with respect to its

PHY signal quality. In such a case the MSS shall restart the initial re-entry sequence or the HO sequence as applicable. No action is required from the BS during an cell selection.

Figure 0b7—Example of cell selection procedure

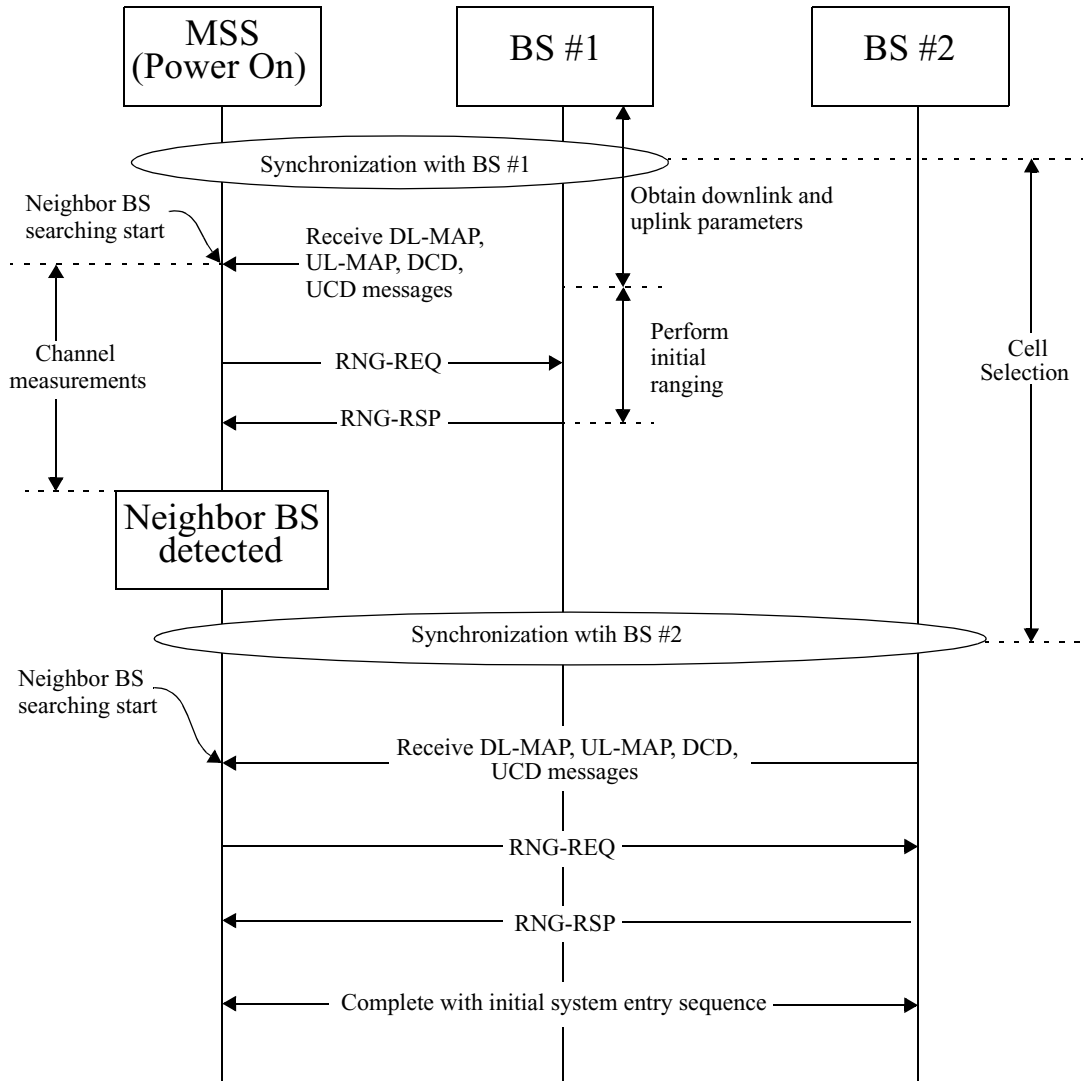

1.3.1.2.2.2 HO initiation

Either an MSS or a BS may initiate a HO by transmitting the MSSHO-REQ or BSHO-REQ MAC messages. It is anticipated that in most situations the MSS will be the initiator of the HO, but sometimes a BS may be the initiator of a HO to facilitate load sharing among BS.

When MSSHO-REQ is sent by an MSS, the MSS may indicate possible target BS (from signal quality point of view). When sent by a BS, the BS may indicate the recommended target BS (based on their capability to

1 meet the MSS QoS requirements). The MSSHO-REQ message may include an indication of the estimated
2 time for performing the HO.
3

4 At the BS side, before sending BSHO-REQ or after receiving a MSSHO-REQ message, the BS shall notify
5 neighboring BS through the backbone of the HO request. The BS shall further acquire from the neighbor BS
6 information regarding their capability of serving the requesting MSS. See section Ranging Request/
7 Response RNG-REQ/RSP for specification of the communication through the backbone network, and the
8 information exchanged between BS.
9

10
11
12
13
14 After receiving MSSHO-REQ or BSHO-REQ message, the receiving party shall respond with a HO-RSP
15 MAC message. When sent by a BS, the HO-RSP message may indicate a recommended target BS. The
16 MSS, at the risk that if it chooses an alternative target BS, it might receive a degraded level of service, may
17 ignore this recommendation (this includes staying with its serving BS, i.e. skipping the HO). The HO-RSP
18 message may also includes an estimation of the time when the HO would take.
19

20 21 **1.3.1.2.2.3 Termination with the serving BS** 22

23
24 After the [MSS/BS]HO-REQ/HO-RSP handshake is completed, the MSS may begin the actual HO. This is
25 done by sending a HO-IND MAC message.
26

27 Upon reception of a HO-IND MAC message, the BS may close all connections and discard MAC state
28 machines and MPDUs associated with the MSS.
29

30 31 **1.3.1.2.3 Drops and corrupted HO attempts** 32

33 A drop is defined as the situation where an MSS has stopped communication with its serving BS (either in
34 the downlink, or in the uplink) before the normal HO sequence outlined in Cell Selection and Termination
35 with the serving BS has been completed.
36

37
38 An MSS can detect a drop by its failure to demodulate the downlink, or by exceeding the RNG-REQ retries
39 limit allowed for the periodic ranging mechanism. A BS can detect a drop by exceeding the RNG-REQ
40 retries limit allowed for the periodic ranging mechanism.
41

42
43 When the MSS has detected a drop, it shall attempt network re-entry with its preferred target BS as outlined
44 in section Re-entry with the target BS. When the BS has detected a drop, it shall react as if a HO-IND MAC
45 message has been received from the dropped MSS.
46

47 48 **1.3.1.2.3.1 Re-entry with the target BS** 49

50 When re-entry with the target BS takes place, the target BS as well as all neighbor BS are aware of the HO in
51 progress (except in a drop situation). At re-entry, the MSS performs the steps as shown in Figure 0b6.
52

53 54 55 56 **1.3.1.2.3.1.1 Synchronize with downlink and obtain parameters** 57

58 For MSS that have used their scanning interval to synchronize with target BS and have decoded the NBR-
59 ADV message, this stage should be immediate. In other situations this procedure defaults to the one speci-
60 fied for initial network entry.
61
62
63
64
65

1.3.1.2.3.1.2 Obtain uplink parameters

For MSS's that have decoded the NBR-ADV message, this stage should be immediate. In other situations this procedure defaults to the one specified for initial network entry.

1.3.1.2.3.1.3 Ranging and uplink parameters adjustment

For MSS's that have used their scanning interval to do ranging with target BS this stage should be immediate. Otherwise, this stage is similar to the one performed at initial network entry. During this stage the MSS is assigned a new basic and primary management CID in the target BS.

As opposed to initial network entry, where this stage is performed on contention basis, here the ranging opportunity may be allocated individually by the BS based on an MSS's 48-bit MAC address identifier. This identifier is forwarded to the target BS via the backbone network (see section Backbone network HO procedures). This is done using the Fast_UL_ranging_IE() (see Fast ranging (Paging) Information Element) in the UL-MAP. When an initial ranging opportunity is not allocated individually, this procedure defaults to the one specified for initial network entry.

1.3.1.2.3.1.4 Negotiate basic capabilities

This stage is identical to the one performed during initial network entry.

1.3.1.2.3.1.5 MSS re-authorization

During this stage the MSS performs the re-authorization part of the PKM protocol used at initial network entry (see IEEE Std 802.16-2001 "Part 16: Air Interface for Fixed Broadband Wireless Access Systems" section 7.2). The BS authenticates the user and as the security context has not changed (it is transferred from the old BS via backbone, see section Backbone network HO procedures) the security sub-layer can continue in normal operation.

[More details should be provided here]

1.3.1.2.3.1.6 Re-register and re-establish provisioned connections

This stage is equivalent to several stages performed during initial network entry. In this stage the MSS re-registers with the BS, and receives on the registration response a conversion table that maps the connections it had with its previous serving BS to a new set of connections on the current serving BS. In doing so, the MSS skips the **establish-IP-connectivity** stage, where it is assigned an IP address for management purposes. This stage is not really skipped during HO, instead it is postponed until the normal-operation stage is reached. The **transfer-operational-parameters** and the **time-of-day establishment** stage are skipped as none of the information contained in the configuration file, nor the time-of-day is expected to change. The MSS attempts the re-registration by sending the normal REG-REQ MAC message. At this stage the MSS has already provides its 48-bit MAC address identifier, and the BS can recognize that the MSS is performing a HO. The BS REG-RSP shall therefore include TLV values for re-establishing the provisioned connections (see section REG-RSP TLVs for connection re-establishment).

1.3.1.2.3.1.7 Commence Normal Operation

At this stage, normal operation commences. The MSS shall re-establish its IP connectivity as specified at initial network entry. Figure <INSERT HERE> shows how a complete HO process might look like in the time domain.

1.3.1.2.4 HO completion

[This section should discuss the following:

Post HO operations (mostly applicable if make-before-break HO is supported)

]

1.3.1.3 Setup and negotiations

[This section should discuss the following:

- Setup and negotiation procedures related to the HO
- PHY dependent parameters and associated handshake
- The model for coexistence of fixed and mobile-SS on the same air-interface instance

[Table 0a in section 6.2.2.3.6 of P802.16a/D7-2002]

Table 0a—Air Interface Nomenclature

Designation	Applicability	PHY specification	Additional MAC requirements	Options	Duplexing alternative
WirelessMAN-SC	10-66 GHz	8.2			TDD FDD
WirelessMAN-SCa	2-11 GHz licensed bands	8.3		AAS (6.2.7.7) ARQ (6.2.4) STC (8.3.3) mobile	TDD FDD
WirelessMAN-OFDM	2-11 GHz licensed bands	8.4		AAS (6.2.7.7) ARQ (6.2.4) Mesh (6.2.6.7) STC (8.4.6) mobile	TDD FDD
WirelessMAN-OFDMA	2-11 GHz licensed bands	8.5		AAS (6.2.7.7) ARQ (6.2.4) STC (8.5.8) mobile	TDD FDD
WirelessHUMAN	2-11 GHz license-exempt bands	[8.3, 8.4 or 8.5] and 8.6	DFS (6.2.14)	AAS (6.2.7.7) ARQ (6.2.4) Mesh (6.2.6.7) (with 8.4 only) STC (8.3.3/8.4/8.5.8)	TDD

[This text should be added to section 6.2.2.3.6 in IEEE Std 802.16-2001 “Part 16: Air Interface for Fixed Broadband Wireless Access Systems”]

3.2.2 Serving BS

For any mobile subscriber station (MSS), the serving BS is the BS with which the MSS has recently performed registration at initial network-entry or during an HO.

3.2.3 Target BS

The BS that an MSS intends to be registered with at the end of a HO.

3.2.4 Neighbor BS

For any MSS, a neighbor BS is a BS whose downlink transmission can be demodulated by the MSS.

3.2.5 Monitored BS

A BS that is monitored by the MSS during its scanning interval.

3.2.6 Selected BS

A subset of Monitored BS, which is selected as potential Target BS.

3.69 Mobile Subscriber Station (MSS)

A subscriber station that supports communications while in motion.

3.70 Handoff (HO)

The process in which an MSS migrates from the air-interface provided by one BS to the air-interface provided by another BS. Two HO variants are defined:

- Hard HO: A HO where service with the new BS starts after a disconnection of service with the old BS.
- Soft HO: A HO where service with the new BS starts before disconnection of the service with the old BS.

3.71 Scanning Interval

A time period intended for monitoring neighbor BS by the MSS, to determine their suitability as targets for HO.

3.72 Mobility Agent (MA):

A higher layer agent which is responsible for mobility.

6.1.3 MAC Service Definition for Mobility Support**6.1.3.1 Primitives for Communication Between CS and MA****6.1.3.1.1 MA to CS: CS_CREATE_CONNECTION.request****6.1.3.1.1.1 Function****6.1.3.1.1.2 Semantics of the service primitive****6.1.3.1.1.3 When generated**

Generated to trigger creation of new connection servicing a newly arrived MSS; specifies classifier(s) to forward data to the connections and QoS parameters for the connection

6.1.3.1.1.4 Effect of receipt

[TBD Parameters]

6.1.3.1.2 MA to CS: CS_CREATE_CONNECTION.response**6.1.3.1.2.1 Function****6.1.3.1.2.2 Semantics of the service primitive****6.1.3.1.2.3 When generated****6.1.3.1.2.4 Effect of receipt**

[TBD Parameters]

6.1.3.1.3 MA to CS: CS_TERMINATE_CONNECTION.request/response**6.1.3.1.3.1 Function****6.1.3.1.3.2 Semantics of the service primitive****6.1.3.1.3.3 When generated**

Generated to trigger termination of connection(s) after an MSS leaves the cell

1 **6.1.3.1.3.4 Effect of receipt**

2
3 *[TBD Parameters]*

4
5
6 **6.1.3.1.4 MA to CS: CS_SDU.request**

7
8 **6.1.3.1.4.1 Function**

9
10 **6.1.3.1.4.2 Semantics of the service primitive**

11
12 **6.1.3.1.4.3 When generated**

13
14
15 Generated to send an SDU to MAC

16
17 **6.1.3.1.4.4 Effect of receipt**

18
19
20 *[TBD Parameters]*

21
22 **6.1.3.1.5 CS to MA: CS_MSS_ARRIVAL.indication**

23
24 **6.1.3.1.5.1 Function**

25
26
27 Signals MSS arrival at the cell

28
29 **6.1.3.1.5.2 Semantics of the service primitive**

30
31 **6.1.3.1.5.3 When generated**

32
33 **6.1.3.1.5.4 Effect of receipt**

34
35
36 *[TBD Parameters]*

37
38 **6.1.3.1.6 CS to MA: CS_MS_DEPARTURE.indication**

39
40 **6.1.3.1.6.1 Function**

41
42
43 Signals MSS departure from the cell

44
45 **6.1.3.1.6.2 Semantics of the service primitive**

46
47 **6.1.3.1.6.3 When generated**

48
49 **6.1.3.1.6.4 Effect of receipt**

50
51
52 *[TBD Parameters]*

53
54
55
56
57
58
59
60
61
62
63
64
65

1 **6.1.3.1.7 CS to MA: CS_SDU.indication**

2
3 **6.1.3.1.7.1 Function**

4
5 **6.1.3.1.7.2 Semantics of the service primitive**

6
7 **6.1.3.1.7.3 When generated**

8
9
10 Generated to signal arrival of an SDU from the backhaul connection

11
12 **6.1.3.1.7.4 Effect of receipt**

13
14
15 *[TBD Parameters]*

16
17 **6.2.2.3.40 Sleep Request message (MOB_SLP-REQ)**

18
19
20 SS supporting sleep-mode uses the MOB_SLP-REQ message to request permission from the BS to enter
21 sleep-mode. The MOB_SLP-REQ message is sent from the SS to the BS on the SS's basic CID.
22

23
24
25 **Table 56aa—Sleep-Request (MOB_SLP-REQ) message format**

26
27

Syntax	Size	Notes
SLP-REQ_Message_Format() {		
Management message type = 45	8 bit	
min-sleeping interval	6 bit	
max-sleeping window	10 bit	
listening interval	8 bit	
}		

28
29
30
31
32
33
34
35
36
37
38
39
40
41

42
43
44 Parameters shall be as follows:

45
46 **Min window**

47 Requested start value for the sleep interval (measured in MAC frames).

48
49 **Max window**

50 Requested stop value for the sleep interval (measured in MAC frames).

51
52 **Listening interval**

53 Requested listening interval (measured in MAC frames).

54
55 **6.2.2.3.41 Sleep Response message (MOB_SLP-RSP)**

56
57 The MOB_SLP-RSP message shall be sent from BS to an SS on the SS's basic CID in response to an
58 MOB_SLP-REQ message. The SS shall enter sleep-mode using the parameters indicated in the message.
59
60
61

62
63 **Table 56ab—Sleep-Response (MOB_SLP-RSP) message format**

1
2
3
4
5
6
7
8
9
10
11
12
13
14
15
16
17
18
19
20
21
22
23
24
25
26
27
28
29
30
31
32
33
34
35
36
37
38
39
40
41
42
43
44
45
46
47
48
49
50
51
52
53
54
55
56
57
58
59
60
61
62
63
64
65

Syntax	Size	Notes
MOB_SLP-RSP_Message_Format() {		
Management message type = 46	8 bit	
Sleep-approved	1 bit	0: Sleep-mode request denied 1: Sleep-mode request approved
If (Sleep-approved == 0) {		
Reserved	7 bit	
} else {		
Start-time	7 bit	
min-sleeping window	6 bit	
max-sleeping window	10 bit	
listening interval	8 bit	
}		
}		

Parameters shall be as follows:

Sleep approved

Defines whether or not the request to enter sleep-mode has been approved by the BS.

Start-time

The number of MAC frames (not including the frame in which the message has been received) until the SS shall enter the first sleep-interval.

Min window

Start value for the sleep interval (measured in MAC frames).

Max window

Stop value for the sleep interval (measured in MAC frames).

Listening interval

Value for the listening interval (measured in MAC frames).

6.2.2.3.42 Traffic Indication message (MOB_TRF-IND)

This message is sent from BS to SS on the broadcast CID. The message is intended for SS's that are in sleep-mode, and is sent during those SS's listening-intervals. The message indicates whether there has been traffic addressed to each SS that is in sleep-mode. An SS that is in sleep-mode during its listening-interval shall decode this message to seek an indication addressed to itself.

When an SS awakens, it will check the frame number to ensure that it did not lose frame synchronization with the BS, if it does not find any positive indication in the MOB_TRF-IND message, it will consider this as a negative indication and shall return to sleep mode.

Table 56ac—Traffic-Indication (MOB_TRF-IND) message format

Syntax	Size	Notes
TRF-IND_Message_Format() {		
Management message type = 47	8 bit	
Num-positive	8 bit	
for (i=0; i< Num-positive; i++) {		
CID	16 bit	Basic CID of the SS
}		
}		

Parameters shall be as follows:

Num-positive

Number of CIDs on the positive indication list.

[This text should be added to section 6.2.2.3.5 in IEEE Std 802.16-2001 “Part 16: Air Interface for Fixed Broadband Wireless Access Systems”]

CID at MAC Header – Shall always be the Initial Ranging CID.

An MSS may use the RNG-REQ message in its scanning interval for associating with a neighbor BS. When associating with a neighbor BS, the MSS shall send the RNG-REQ message with the following TLV parameters,

SS MAC Address – A 48-bit unique identifier for the MSS.

MSS Association Channel ID – An identifier of the downlink channel on which the MSS is currently registered. This is an 8-bit field. The downlink channel identifier should be unique networkwide.

[This text should be added to section 6.2.2.3.6 in IEEE Std 802.16-2001 “Part 16: Air Interface for Fixed Broadband Wireless Access Systems”]

When a BS sends a RNG-RSP message in response to a RNG-REQ message containing an **MSS Association Channel ID TLV**, the BS may include the following TLV parameter in the RNG-RSP message,

Service Level Prediction _ This value indicates the level of service the MSS can expect from this BS. The following encodings apply:

0 = No service possible for this MSS.

1 = Some service is available for the MSS.

2 = Service with QoS specified at ASA server (for the MSS identified by the 48-bit MAC address) is available.

This is an 8-bit field.

The following TLVs shall be included in the REG-RSP for MSS's recognized by the BS through their 48-bit MAC address (provided in the RNG-REQ message) as MSS's that are performing HO,

CID_updtae – The CID_update is a TLV value that provides a shorthand method for renewing a connection used in the previous serving BS. The TLV specifies a CID in the new serving BS that shall replace a CID used in the previous serving BS. All the service flows and parameters associated with the old CID remain unchanged. (See).

Connection_Info – The Connection_Info is a compound TLV value that encapsulates the **Service Flow Parameters** and the **CS Parameter Encodings** TLVs allowed on the DSA-RSP. This TLV enables the new serving BS to renew a connection used in the previous serving BS, but with different QoS settings.

[add the following new MAC messages after section 6.2.2.3.42]

6.2.2.3.43 Neighbor Advertisement (MOB_NBR-ADV) message

An NBR-ADV message shall be broadcasted by a BS at a periodic interval () to define the characteristics of neighbor BS.

Table 56ad—MOB_NBR-ADV Message Format

Syntax	Size	Notes
MOB_NBR-ADV_Message_Format() {		
Management Message Type = ?	8 bits	
N_NEIGHBORS	8 bits	
For (j=0 ; j<N_NEIGHBORS ; j++) {		
Neighbor BS-ID	48 bits	
Configuration Change Count	8 bits	
Physical Frequency	32 bits	
TLV Encoded Neighbor information	Variable	TLV specific
}		
}		

A BS shall generate MOB_NBR-ADV messages in the format shown in Table 56ad. The following parameters shall be included in the MOB_NBR-ADV message,

N_Neighbors – Number of advertised neighbor BS

For each advertised neighbor BS, the following parameters shall be included:

Neighbor BS-ID – Same as the **Base Station ID** parameter in the DL-MAP message of neighbor BS

Configuration Change Count – Incremented by one (modulo 256) whenever any of the values relating to this neighbor BS change. If the value of this count in a subsequent MOB_NBR-ADV message remains the same, the MSS can quickly to disregard the TLV encoded information

Physical Frequency – DL center frequency (kHz).

All other parameters are coded as TLV value (see TBD).

For each advertised neighbor BS, the following TLV parameters may be included,

DCD_settings – The DCD_settings is a compound TLV value that encapsulates a DCD message that may be transmitted in the advertised BS downlink channel. This information is intended to enable fast synchronization of the MSS with the advertised BS downlink.

UCD_settings – The UCD_settings is a compound TLV value that encapsulates a UCD message that may be transmitted in the advertised BS downlink channel. This information is intended to enable fast synchronization of the MSS with the advertised BS uplink.

6.2.2.3.44 Scanning Interval Allocation Request (MOB_SCN-REQ) message

A MOB_SCN-REQ message may be transmitted by an MSS to request a scanning interval for the purpose of seeking neighbor BS, and determining their suitability as targets for HO.

Table 56ae—MOB_SCN-REQ Message Format

Syntax	Size	Notes
MOB_SCN-REQ_Message_Format() {		
Management Message Type = ?	8 bits	
Scan Duration	16 bits	Units are frames.
}		

An MSS shall generate MOB_SCN-REQ messages in the format shown in Table 56ae. The following parameters shall be included in the MOB_SCN-REQ message,

Scan Duration – The requested period of time for the scan. The units are PHY-dependent, as specified in .

6.2.2.3.45 BS HO Request (MOB_BSHO-REQ) message

The BS may transmit a MOB_BSHO-REQ message when it wants to initiate an HO. The message shall be transmitted on the basic CID.

Table 56af—MOB_BSHO-REQ Message Format

Syntax	Size	Notes
MOB_BSHO-REQ_Message_Format() {		
Management Message Type = ?	8 bits	
N_Recommended	8 bits	
For (j=0 ; j<N_NEIGHBORS ; j++) {		

Neighbor BS-ID	48 bits	
}		
}		

A BS shall generate MOB_BSHO-REQ messages in the format shown in Table 56af. The following parameters shall be included in the MOB_BSHO-REQ message,

N_Recommended – Number of recommended neighbor BS

For each recommended neighbor BS, the following parameter shall be included,

Neighbor BS-ID – Same as the Base Station ID parameter in the DL-MAP message of neighbor BS

6.2.2.3.46 MSS HO Request (MOB_MSSHO-REQ) message

The MSS may transmit an MOB_MSSHO-REQ message when it wants to initiate an HO. The message shall be transmitted on the basic CID.

Table 56ag—MOB_MSSHO-REQ Message Format

Syntax	Size	Notes
MOB_MSSHO-REQ_Message_Format() {		
Management Message Type = ?	8 bits	
N_Recommended	8 bits	
For (j=0 ; j<N_NEIGHBORS ; j++) {		
Neighbor BS-ID	48 bits	
BS S/(N+I)	8 bits	
}		
}		

An MSS shall generate MOB_MSSHO-REQ messages in the format shown in Table 56ag. The following parameters shall be included in the MOB_MSSHO-REQ message,

N_Recommended – Number of recommended neighbor BS

For each recommended neighbor BS, the following parameters shall be included,

Neighbor BS-ID – Same as the **Base Station ID** parameter in the DL-MAP message of neighbor BS

BS S/(N + I) – This parameter indicates the signal to noise and interference ratio measured by the MSS from the particular BS. The value shall be interpreted as an unsigned byte with units of 0.25dB.

6.2.2.3.47 HO Response (MOB_HO-RSP) message

Either an MSS or a BS shall transmit an MOB_HO-RSP message upon reception of MOB_HO-REQ message. The message shall be transmitted on the basic CID.

Table 56ah—MOB_HO-RSP Message Format

Syntax	Size	Notes
MOB_HO-RSP_Message_Format() {		
Management Message Type = ?	8 bits	
Estimated HO time	8 bits	
N_Recommended	8 bits	
For (j=0 ; j<N_NEIGHBORS ; j++) {		
Neighbor BS-ID	48 bits	
BS rating	8 bits	This parameter exists only when the message is sent by the BS
}		
}		

A BS or MSS shall generate MOB_HO-RSP messages in the format shown in Table 56ah. The following parameters shall be included in the MOB_HO-RSP message,

Estimated HO time – Estimated number of MAC frames until the HO will take place. A value of zero in this parameter signifies that this parameter should be ignored.

N_Recommended – Number of recommended neighbor BS

For each recommended neighbor BS, the following parameters shall be included,

Neighbor BS-ID – Same as the **Base Station ID** parameter in the DL-MAP message of neighbor BS

BS rating – This parameter exists only when the BS sends the MOB_HO-RSP message. The parameter indicates the relative level to which the target BS could meet the MSS QoS requirements. A value of zero in this parameter signifies that this parameter should be ignored.

6.2.2.3.48 HO Indication (MOB_HO-IND) message

An MSS shall transmit a MOB_HO-IND message for final indication that it is about to perform a HO. The message shall be transmitted on the basic CID.

Table 56ai—MOB_HO-IND Message Format

Syntax	Size	Notes
MOB_HO-IND_Message_Format() {		
Management Message Type = ?	8 bits	

TLV Encoded Information	Variable	TLV specific
}		

An MSS shall generate MOB_HO-IND messages in the format shown in Table 56ai. If Privacy is enabled, the MOB_HO-IND message shall include the following TLV value,

HMAC Tuple (see 11.4.10 in IEEE 802.16-2001) – The HMAC Tuple Attribute contains a keyed Message digest (to authenticate the sender).

6.2.16 Sleep-mode for mobility-supporting SS

6.2.16.1 Introduction

Sleep-mode is a mode in which SS's supporting mobility may power down. Sleep-mode is intended to enable mobility-supporting SS's to minimize their energy usage while staying connected to the network. Implementation of power-save mode is optional.

An SS that supports sleep-mode can be in one of two modes:

- Awake
- Sleep

When an SS is in awake-mode, it is receiving and transmitting PDUs in a normal fashion. When the SS is in a sleep-mode, it does not send or receive PDUs. In sleep-mode the SS may power down.

Two intervals are defined:

Sleep-interval

A time duration, measured in whole MAC frames, where the SS is in sleep-mode. During consecutive sleep periods the sleep-interval shall be updated using an exponentially increasing algorithm with adjustable minimum and maximum limits.

Listening-interval

Length, measured in whole frames, of the listening interval. During this interval the SS shall decide whether to stay awake or go back to sleep based on an indication from the BS. The Listening-interval duration is negotiated between the BS and the SS.

Before entering sleep-mode the SS shall inform the BS and obtain its approval. The BS may buffer (or it may drop) incoming PDUs addressed to the sleeping SS, and shall send notification to the SS in its awakening periods about whether data has been addressed for it.

An SS shall awake according to the sleep-interval and check whether there were PDUs addressed for it. If such PDUs exist, it shall remain awake. An SS may terminate sleep-mode and return to awake-mode any-time (i.e. there is no need to wait until the sleep-interval is over). If the BS receives an MPDU from an SS that is supposed to be in sleep-mode, the BS shall assume that the SS is no longer in sleep-mode.

Traffic indication message (TRF-IND) shall be sent by the BS on the broadcast CID periodically. If the number of positive indications is zero, the BS sends an empty indication message, that is, TRF-IND message with num-positive=0.

1 When its sleep-interval timeouts, the SS shall awake to listen to the DL transmissions until it receives a
2 TRF-IND message. If there is a positive indication to the SS, it shall remain awake. Otherwise, the SS may
3 return to its sleep-mode.
4

5
6 In this way, the listening interval parameter is no longer needed to be negotiated between SS and BS in the
7 SLP-REQ and SLP-RSP messages. The interval between two TRF-IND messages sent by the BS is the max-
8 imum listening interval for all SS's supporting sleep-mode. It can be sent in the SLP-RSP message only.
9

10 11 12 13 **6.2.16.2 Sleep-interval update algorithm**

14
15 An SS shall enter sleep-mode after receiving an SLP-RSP message from the BS. In the first time it enters
16 sleep-mode, it shall use the min-sleeping window value for the sleep interval. If during the following listen-
17 ing interval the BS has not signaled that traffic has been addressed for the SS, the SS shall re-enter sleep-
18 mode an double the duration of the sleep-interval. This procedure shall be repeated as long as the resulting
19 sleep-interval does not exceed the max-sleeping window value.
20
21

22 **6.2.16.3 Traffic indication signaling**

23
24 A BS shall notify each SS in sleep-mode, during its listening-interval, if traffic has been addressed to it.. The
25 indication is sent on the TRF-IND broadcast message. The SS shall examine the MAC frame number from
26 the PHY Synchronization Field and shall verify it synchronization with the BS. If the expected MAC frame
27 number is different than found frame number, the SS shall return into awake mode.
28
29

30
31 If the SS did not find any positive indication with it's CID in the TRF-IND it shall consider this as a negative
32 indication and shall continue in sleep mode.
33
34
35
36
37
38
39
40
41
42
43
44
45
46
47
48
49
50
51
52
53
54
55
56
57
58
59
60
61
62
63
64
65

6.2.16.4 Example of sleep-mode operation

Figure 59b1—Example of sleep-mode operation

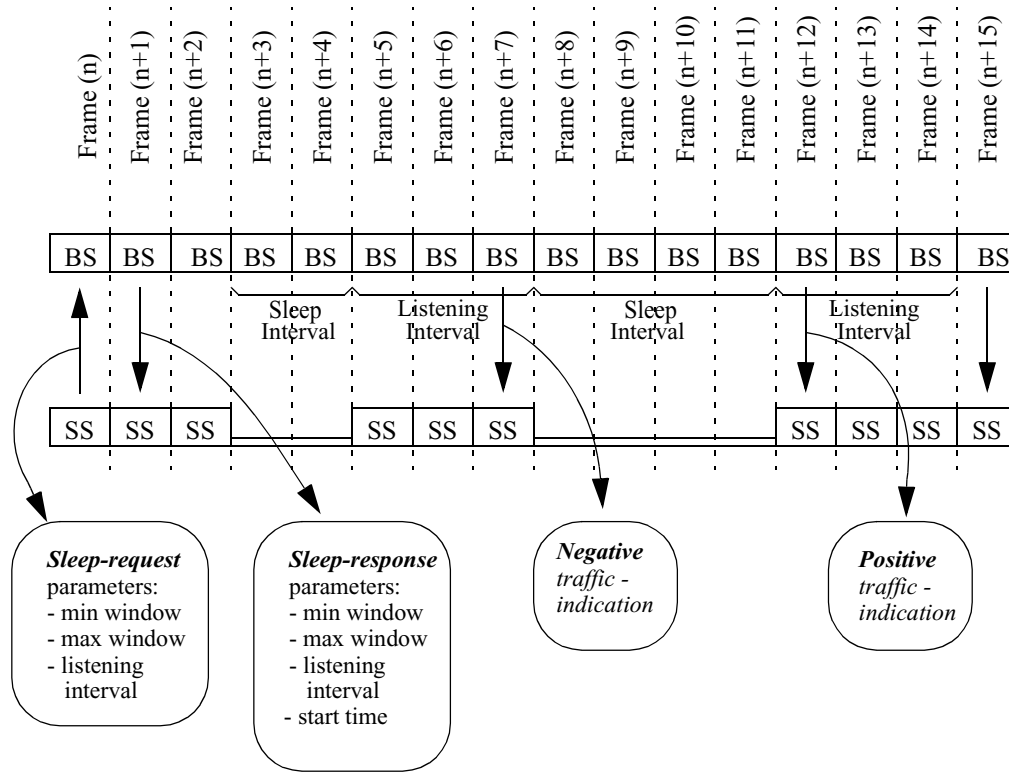

[Insert the following text after section 8.3.1.4.5.2]

8.3.1.4.5.2.1 Scanning Information Element

A Scanning_IE shall be placed in the DL-MAP message by a BS in response to an SCN-REQ message sent by an MSS. The Scanning_IE shall be placed in the extend DIUC (extension code = ?) within a DL-MAP IE. A value of zero in the Scan Duration field shall be interpreted as denial of the SCN-REQ. A BS may also send an unsolicited Scanning_IE.

The format of the IE is PHY dependent as shown in Figure 116w1.

Table 116w1—SCa PHY Scanning IE Format

Syntax	Size	Notes
Scanning_IE {		
CID	16 bits	MSS's basic CID

Scan Start	8 bits	Offset (in units of min-slots) to the start of the scanning interval from the mini-slot boundary specified by the downlink Allocation_Start_Time
Scan Duration	8 bits	Duration (in units of MAC frames) where the MSS may scan for neighbor BS.
}		

[Insert the following after section 8.3.1.4.5.3]

8.3.1.4.5.3.1 Fast ranging (Paging) Information Element

A Fast_UL_ranging_IE may be placed in the UL-MAP message by a BS to provide a non-contention based initial-ranging opportunity. The Fast_UL_ranging_IE shall be placed in the extend UIUC (extension code = ?) within a UL-MAP IE.

The format of the IE is PHY dependent as shown in Figure 116z1.

Table 116z1—Fast Ranging Format IE: SCa PHY

Syntax	Size	Notes
Fast_UL_ranging_IE {		
MAC address	48 bits	MSS's MAC address as provided on the RNG_REQ message on initial system entry
UIUC	4 bits	UIUC ≠ 15. A four-bit code used to define the type of uplink access and the burst type associated with that access.
Offset	12 bits	Indicates the start time, in units of minislots, of the burst relative to the Allocation Start Time given in the UL-MAP message. The time instants indicated by offsets are the transmission times of the first symbol of the burst including preamble.
Reserved	4 bits	
}		

[Insert the following after section 8.4.4.3.5]

8.4.4.3.6 Fast ranging (Paging) Information Element

A Fast_UL_ranging_IE may be placed in the UL-MAP message by a BS to provide a non-contention based initial-ranging opportunity. The Fast_UL_ranging_IE shall be placed in the extend UIUC (extension code = ?) within a UL-MAP IE.

The format of the IE is PHY dependent as shown in Figure 116ao1.

Table 116ao1—Fast Ranging Format IE: OFDM PHY

Syntax	Size	Notes
--------	------	-------

Fast_UL_ranging_IE {		
MAC address	48 bits	MSS's MAC address as provided on the RNG_REQ message on initial system entry
UIUC	4 bits	UIUC ≠ 15. UIUC ≠ 4. A four-bit code used to define the type of uplink access and the burst type associated with that access.
Duration	12 bits	The Duration indicates the length, in units of OFDM symbols, of the allocation. The start time of the first allocation shall be the Allocation Start Time given in the UL-MAP message.
Reserved	4 bits	
}		

[Insert the following text after 8.4.5.2.4]

8.4.5.2.5 Scanning Information Element

A Scanning_IE shall be placed in the DL-MAP message by a BS in response to an SCN-REQ message sent by an MSS. The Scanning_IE shall be placed in the extend DIUC (extension code = ?) within a DL-MAP IE. A value of zero in the Scan Duration field shall be interpreted as denial of the SCN-REQ. A BS may also send an unsolicited Scanning_IE.

The format of the IE is PHY dependent as shown in <table>.

Table 116aw1—OFDM PHY Scanning IE Format

Syntax	Size	Notes
Scanning_IE {		
CID	16 bits	MSS's basic CID
Scan Start	8 bits	Indicates the scanning interval start time, in units of OFDM symbol duration, relative to the start of the first symbol of the PHY PDU (including preamble) where the DL-MAP message is transmitted.
Scan Duration	8 bits	Duration (in units of MAC frames) where the MSS may scan for neighbor BS.
}		

[Insert after section 8.5.1.1]

8.5.1.2 System aspects

There are several deployment scenarios for the OFDMA mode, the two major types are:

- Multi Cell Multi Frequency Network (MFN)
- Multi Cell Single Frequency Network (SFN)

1 The first option is the regular multi-cell with different frequencies allocated to each sector. Another possibil-
2 ity in OFDMA is to work with the SFN option, which means that each sector would use a logical entity of
3 Sub-Channels (which will include several sub-channels). SFN allows the usage of a single channel to be
4 divided into logical entities, rather than splitting into smaller physical units, this way the frequency diver-
5 sity of each logical entity still has the same properties as the basic channel.
6

7
8 The key features of using the SFN architecture are:
9

- 10 — ·Bandwidth sharing between sectors
- 11 — ·Flexible deployment, without the need to change RF components.
- 12 — ·Capacity increase in a multi sector configuration (by using the same principles as CDMA)
- 13 — ·Easy extension of existing deployments
- 14 — ·Faster handoffs
- 15 — ·Soft handoff possibility without the need to switch RF channels
- 16 — ·Frequency diversity

17
18
19
20
21
22 The PHY layer supports this splitting seamlessly, but has to be aware that:
23

- 24 — ·Not all sub-channels might be used in the logical channel.

25
26
27
28
29 *[Insert after section 8.5.4.2]*
30

31 **8.5.4.3 Preamble only signal**

32 A preamble only symbol shall be added to the DL transmission; this preamble shall be located before the
33 first the frame preamble (defined in section 8.5.9.4.3.1) as shown in Figure 128av1. This preamble could be
34 used in a multi-cell deployment for estimation, relative location calculation between base-stations and
35 knowledge about the reception power and quality of the surrounding base-stations.
36
37
38
39
40
41
42
43
44
45
46
47
48
49
50
51
52
53
54
55
56
57
58
59
60
61
62
63
64
65

Figure 128av1—Preamble Location within the frame transmission in TDD/FDD

1
2
3
4
5
6
7
8
9
10
11
12
13
14
15
16
17
18
19
20
21
22
23
24
25
26
27
28
29
30
31
32
33
34
35
36
37
38
39
40
41
42
43
44
45
46
47
48
49
50
51
52
53
54
55
56
57
58
59
60
61
62
63
64
65

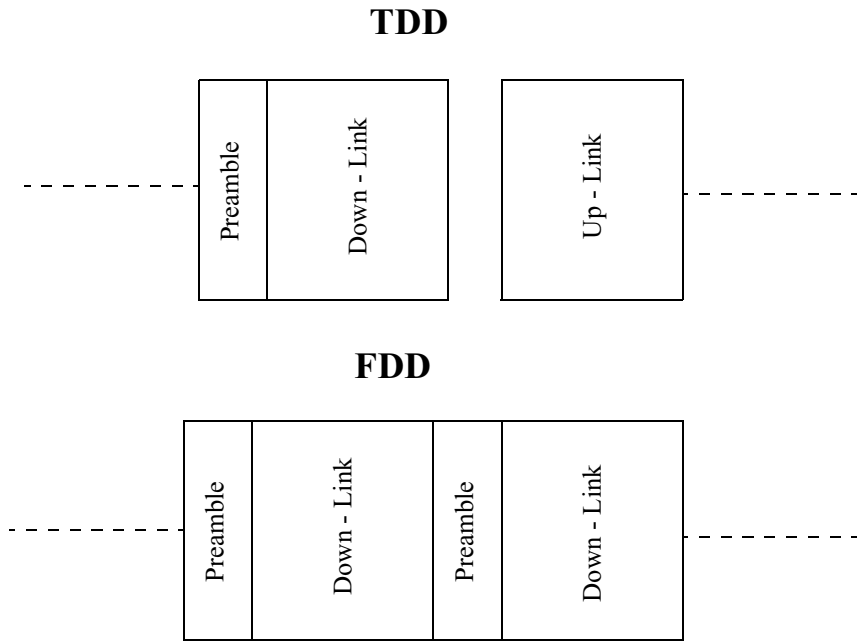

The preamble will be transmitted on the carrier indices that obey the following formula:

$$PN_{ID} = UsedCarriers_{mod(6)}$$

(65a)

where:

- PN_{ID}
An integer 0-5, setting the carriers location and PN sequence used
- $UsedCarriers$
The indices of the carrier to modulate

As can be noticed from the formula for which PN_{ID} differs in their modulo 6 calculation we have 6 different preambles, this will allow to work in a 6 sector deployment with each sector transmitting different preambles even for a single frequency deployment.

The modulation of the pilots shall be set accordingly to section 8.5.9.4.3, the initialization of the PRBS shall be set according to the following table:

Table 116bi1—PRBS Initialization

PN_{ID}	PRBS Initialization
0	[1111111111]
1	[00011101010]
2	[11001010111]
3	[10111000101]
4	[01010100011]
5	[01110001100]

The modulation of the pilots in the frame preamble specified in section 8.5.9.4.3.1 shall be set according to the following table:

Table 116bi2—Pilot Modulation

PN_{ID}	PRBS Initialization
0	[01010101010]
1	[00011101010]
2	[10011010011]
3	[01000101010]
4	[11100100011]
5	[00111001111]

[Insert after section 8.5.4.6]

8.5.4.7 Logical channels (for 802.16e)

When the SFN scheme is deployed, each sector may be allocated with a different set of sub-channels as the usable resource.

The set of sub-channels, which is allocated to each BS, shall be referred as *Logical Channel*.

Each BS shall be allocated with a specific logical channel through the management layer.

The allocation of logical channels to the BSs may be dynamic and can be dependent of the current load distribution within the cell, i.e. if BS₁ does not have many registered SSs, while BS₂ approaching it's maximum capacity with current allocation, then the sub-channels can be moved from BS₁'s logical channel to BS₂ logical channel.

[In section 8.5.5.2 DL-MAP Information Element format:]

Change number of bits of **OFDM Symbol offset** field from 10 to 9.

Change number of bits of **Boosting**¹ field from 2 to 3.

Changed the possible values of the **Boosting** field as follows: 000: normal (not boosted); 001: +3dB; 010: +6dB; 011: +9dB; 100: -3dB; 101: -6dB; 110: -9dB; 111: -12dB;

[Insert after section 8.5.5.2]

8.5.5.2.1 DL-MAP information IE

The mini sub-channel Numbering shall be done as follows:

Table 116bm1—OFDMA DL-MAP Information Element format

Syntax	Size	Notes
DL-Map_Information_Element() {		
DIUC	4 bits	
if (DIUC == 15) {		
Extended DIUC dependent IE	Variable	AAS_DL_IE()
} else {		
OFDM Symbol offset	8 bits	
Subchannel offset	5 bits	
Boosting	3 bits	000: normal (not boosted); 001: +6dB; 010: -6dB; 011: +9dB; 100: +3dB; 101: -3dB; 110: -9dB; 111: -12dB;
No. OFDM Symbols	8 bits	
No. Subchannels	5 bits	
Mini_Subchannel index	3 bits	000 – no mini subchannels used; 001 – mini subchannel 1 is allocated 010 – mini subchannel 2 is allocated 011 – mini subchannel 3 is allocated 100 – mini subchannel 4 is allocated 101 – mini subchannel 5 is allocated 110,111 – reserved
}		
}		

[Insert the following text after 8.5.5.2.3]

8.5.5.2.4 Scanning Information Element

A Scanning_IE shall be placed in the DL-MAP message by a BS in response to an SCN-REQ message sent by an MSS. The Scanning_IE shall be placed in the extend DIUC (extension code = ?) within a DL-MAP IE.

¹* This field should be moved from UL-MAP IE to DL-MAP IE due to an editorial error, and should be fixed in the errata process.

A value of zero in the Scan Duration field shall be interpreted as denial of the SCN-REQ. A BS may also send an unsolicited Scanning_IE.

The format of the IE is PHY dependent as shown in Figure 116bo1.

Table 116bo1—OFDMA PHY Scanning IE Format

Syntax	Size	Notes
Scanning_IE {		
CID	16 bits	MSS's basic CID
Scan Start	8 bits	The offset of the OFDM symbol in which the scanning interval starts. Measured in OFDM symbols from the time specified by the Allocation_Start_time field in the DL-MAP
Scan Duration	8 bits	Duration (in units of MAC frames) where the MSS may scan for neighbor BS.
}		

Table 8: Scanning_IE format

[Insert after section 8.5.5.3]

8.5.5.3.1 UL-MAP information IE

The mini sub-channel Numbering shall be done as follows:

Table 116bq1—OFDMA UL-MAP Information Element format

Syntax	Size	Notes
UL-Map_Information_Element() {		
CID	16 bits	
UIUC	4 bits	
if (UIUC == 4) {		
CDMA_Allocation_IE()	52 bits	
} else if (UIUC == 15) {		
Extended UIUC dependent IE	Variable	Power_Control_IE() or AAS_UL_IE()
} else {		
OFDM Symbol offset	10 bits	
Subchannel offset	6 bits	
No. OFDM Symbols	8 bits	

No. Subchannels	5 bits	
Mini_Subchannel index	3 bits	000 – no mini subchannels used; 001 – mini subchannel 1 is allocated 010 – mini subchannel 2 is allocated 011 – mini subchannel 3 is allocated 100 – mini subchannel 4 is allocated 101 – mini subchannel 5 is allocated 110,111 – reserved
}		
}		

[Insert the following after section 8.5.5.3.4]

8.5.5.3.5 Fast ranging (Paging) Information Element

A Fast_UL_ranging_IE may be placed in the UL-MAP message by a BS to provide a non-contention based initial-ranging opportunity. The Fast_UL_ranging_IE shall be placed in the extend UIUC (extension code = ?) within a UL-MAP IE.

The format of the IE is PHY dependent as shown in Figure 116bt1.

Table 116bt1—Fast Ranging Format IE: OFDMA PHY

Syntax	Size	Notes
Fast_UL_ranging_IE {		
MAC address	48 bits	MSS MAC address as provided on the RNG_REQ message on initial system entry
UIUC	4 bits	UIUC ≠ 15. A four-bit code used to define the type of uplink access and the burst type associated with that access.
OFDM Symbol offset	10 bits	The offset of the OFDM symbol in which the burst starts, the offset value is defined in units of OFDM symbols and is relevant to the Allocation Start Time field given in the UL-MAP message.
Subchannel offset	6 bits	The lowest index OFDMA subchannel used for carrying the burst, starting from subchannel 0.
No. OFDM Symbols	10 bits	The number of OFDM symbols that are used to carry the UL Burst
No. Subchannels	6 bits	The number OFDMA subchannels with subsequent indexes, used to carry the burst.
Reserved	4 bits	
}		

[Insert after section 8.5.5.3.4]

8.5.5.3.5 UL-MAP Fast tracking indication

The UL-MAP Fast Indication in an UL-MAP entry used to provide fast power, time and frequency indications\corrections to SS's that have transmitted in the previous MAC frame.

The extended UIUC=15 shall be used for this IE with sub-code 0x03

The CID used in the Information Element should be a broadcast CID.

Table 116bt2—UL fast tracking Information Element

Syntax	Size	Notes
UL_Fast_tracking_IE() {		
extended UIUC	4 bit s	Fast-Indication = 0x03
Number of Elements	8 bit s	Number of Fast Indication bytes
for ($i = 1; i \leq n; i++$) {		For each Fast Indication bytes 1 to n ($n = \text{Number of Element field}$)
Power correction	2	Power correction indication, 00: no change; 01: +2dB; 10: -1dB; 11: -2dB
Frequency correction	4	Frequency correction. Units are PHY-specific For OFDM/OFDMA: The correction is 0.1% of the carrier spacing multiplied by the 4-bit number interpreted as a signed integer (i.e. 1000: -8; ... 0000: 0; ... 0111: 7)
Time correction	2	Time offset correction. Units are PHY-specific For OFDM/OFDMA: The correction is $\text{floor}(2 / F_s)$ multiplied by, 00: 0; 01: 1; 10: -1; 11: Not used
}		
}		

The UL Fast tracking IE is an optional field in the UL_MAP. When this IE is sent it provides an indication about corrections that should be applied by SS's that have transmitted in the pervious UL MAC frame. Each

1 Indication byte shall correspond to one unicast allocation-IE that has indicated an allocation of an uplink
 2 transmission slot in the previous UL_MAP. The order of the indication bytes shall be the same as the order
 3 of the unicast allocation-IE in the UL-MAP.
 4

5
 6 *[Insert after section 8.5.6.1.2]*
 7

8 8.5.6.4 Mini Sub-Channels (for 802.16e) 9

10 The OFDMA Sub-Channel shall be further divided into smaller granularity mini Sub-Channels in order to
 11 gain more power concentration and better granularity.
 12

13 8.5.6.4.1 DL Mini Sub-Channels 14

15 The regular Sub-Channel in the DL shall be further divided into 6 mini sub-channels. The regular sub-chan-
 16 nel includes 48 data carriers, and a burst consists 3 time symbols, in order to keep backward compatibility
 17 and not change the MAC frame structure the mini sub-channel will consists 8 carriers and a mini burst will
 18 consist 3 time symbol, this will give us a total of 24 data carriers per burst (1/6 the granularity of a regular
 19 burst).
 20
 21
 22

23 The formula that defines what are the carrier indices allocated to a mini sub-channel out from the regular
 24 sub-channel:
 25

$$26 \quad mCarrier[j, k, i] = Carrier[6j + k, i]$$

27
 28
 29
 30
 31
 32
 33
 34
 35
 36
 37 where:

38
 39 $mCarrier[j, k, i]$ defines carrier j of mini sub-channel k within subchannel i ,
 40 $carrier[x, y]$ defines carrier x of sub-channel y , as defined in 8.5.6.1.2.
 41
 42

43 This structure enables each mini sub-channel to have the best frequency diversity, but still maintain a simple
 44 derivation from the regular sub-channel.
 45

46 The usage of regular sub-channels and mini sub-channels is allowed in the system and therefore coexistence
 47 with 802.16a user is possible (a sub-channel that is divided into mini sub-channels will be used only in this
 48 structure).
 49
 50

51 8.5.6.4.2 UL Mini Sub-Channels 52

53 The regular Sub-Channel in the UL shall be further divided into 5 mini sub-channels. The 53 carriers of the
 54 regular sub-channel will be divided into 3 mini sub-channels each including 11 carriers and another 2 mini
 55 sub-channels each including 10 carriers.
 56
 57

58 The carriers which obey the following formula, are allocated to one mini sub-channel:
 59
 60
 61
 62
 63
 64
 65

1
2
3
4
5
6
7
8
9
10
11
12
13
14
15
16
17
18
19
20
21
22
23
24
25
26
27
28
29
30
31
32
33
34
35
36
37
38
39
40
41
42
43
44
45
46
47
48
49
50
51
52
53
54
55
56
57
58
59
60
61
62
63
64
65

$$Carrier[j, i]_{mod(5)} = k$$

where:

$Carrier[j, i]$ defines carrier j of subchannel i as defined in 8.5.6.1.2
 k defines mini sub-channel k .

The structure of the mini sub-channel includes 8 data carriers and 2/3 pilot carriers.

Figure 128bb1 depicts the mini sub-channel organization:

Figure 128bb1—Mini Sub-Channel Organization and Structure

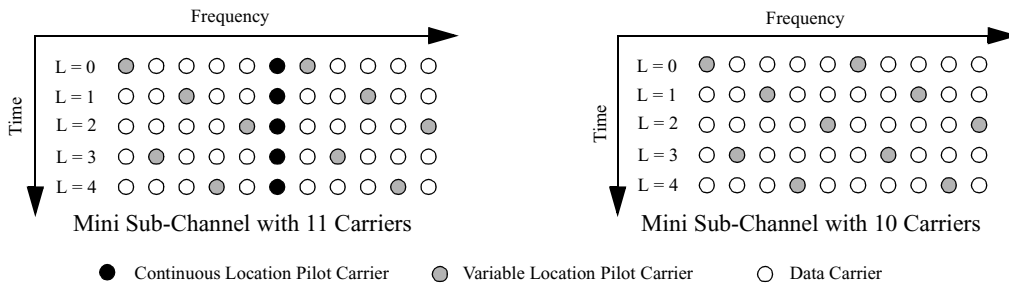

The structure proposed will enable a module 5 MAC frame structure, with maximum frequency diversity.

8.5.6.4.3 Randomization

The randomization procedure will be performed as specified in section 8.5.9.1, with the same initialization procedure. The Sub-Channel offset, which sets the 6 LSB bits of the randomizer, shall be taken from the LSB bits of the mini Sub-Channel numbering.

8.5.6.4.4 FEC

The FEC option proposed shall include CTC and performed per mini burst, with the following parameters (and performed as described in section 8.5.9.2.3):

Table 116by1—FEC Options

Modulation	Data Block Size (Bytes)	Coded Block Size (Bytes)	Code Rate	N	P0	P1	P2	P3
QPSK	3	6	—					
QPSK	4.5	6	—					
16QAM	6	12	—					
16QAM	9	12	—					

64QAM	9	18	2/3					
64QAM	13.5	18	–					

8.5.6.4.5 Interleaving

The interleaving shall be performed per mini burst, as described in section 8.5.9.3.

The parameters for the interleaver are:

Table 116by2—Interleaving

Modulation	Coded Bits Per Block (Ncbps)	Modulo used (d)
QPSK	48	16
16QAM	96	18
64QAM	144	16

8.5.6.4.6 Modulation

As described in section 8.5.9.4.

8.5.6.4.7 Pilots Modulation

The modulation of the pilots shall be set accordingly to section 8.5.9.4.3, the initialization of the PRBS shall be set according to the following table:

Table 116by3—PRBS Initialization

<i>PN_{ID}</i>	PRBS Initialization
0	[1111111111]
1	[00011101010]
2	[11001010111]
3	[10111000101]
4	[01010100011]
5	[01110001100]

The modulation of the pilots in the frame preamble specified in section 8.5.9.4.3.1 shall be set according to the following table:

Table 116by4—Frame Preamble Pilot Modulation

<i>PN_{ID}</i>	PRBS Initialization
------------------------	---------------------

1
2
3
4
5
6
7
8
9
10
11
12
13
14
15
16
17
18
19
20
21
22
23
24
25
26
27
28
29
30
31
32
33
34
35
36
37
38
39
40
41
42
43
44
45
46
47
48
49
50
51
52
53
54
55
56
57
58
59
60
61
62
63
64
65

0	[01010101010]
1	[00011101010]
2	[10011010011]
3	[01000101010]
4	[11100100011]
5	[00111001111]

10.1 Global Values

Add the following values to table 118:

Table 118a1—Parameters and Constants

System	Name	Time Reference	Minimum Value	Default Value	Maximum Value
SS	Min_Sleep_Interval	Minimum sleeping time allowed to SS	2ms		
SS	Max_Sleep_Interval	Maximum sleeping time allowed to SS			5s
SS	Listening_Interval	The time duration during which the SS, after waking up and synchronizing with the DL transmissions, can demodulate downlink transmissions and decides whether to stay awake or go back to sleep			

[Add the following values to table 118a]

Table 118a2—Parameters and Constants

System	Name	Time reference	Min. value	Default value	Max value
BS	NBR-ADV interval	Nominal time between transmission of NBR-ADV messages			1s
BS	ASC-AGING-TIMER	Nominal time for aging of MSS associations	0.1s		

10.1.0.1 Ranging Request/Response RNG-REQ/RSP

11.1.4 REG-RSP TLVs for connection re-establishment

[Add the following rows to table 127a]

Table 127b—REG-RSP Encodings

Name	Type (1 byte)	Length (1 byte)	Value (Variable-length)
CID_update	?	16-bits	CID in the previous serving BS
		16-bits	Replacement CID in the current serving BS
Connection_Info	?	Variable	The Connection_Info is a compound TLV value that encapsulates the Service Flow Parameters and the CS Parameter Encodings TLVs allowed on the DSA-RSP message. All the rules and settings that apply to the TLVs when used in the DSA-RSP message apply to the contents encapsulated in this TLV.

[Insert the following section after 11.1.6]

11.1.7 NBR-ADV Message Encodings

Table 127c—NBR-ADV Encodings

Name	Type (1 byte)	Length (1 byte)	Value (Variable-length)
DCD_settings	?	Variable	The DCD_settings is a compound TLV that encapsulates an entire DCD message (excluding the generic MAC header). All the rules and settings that apply to the DCD message apply to the contents encapsulated in this TLV.
UCD_settings	?	Variable	The UCD_settings is a compound TLV value that encapsulates an entire UCD message (excluding the generic MAC header). All the rules and settings that apply to the UCD message apply to the contents encapsulated in this TLV.

[Insert a new Annex]

Annex C Backbone network HO procedures

[This section should contain the procedures performed on backbone to support HO such that BS from different manufacturers are interoperable. The section should address issues such as,

- Centralized HO controller and/or distributed decision
- The information that should be exchanged (Post-HO, Pre-HO and during HO)
- Information exchange model (publishing, on request, combined)

- The transport protocol to use
- Formal definition of the messages

C.1 Backbone network services

The backbone network provides a backhaul transmission path to the BS, and may provide other services at the control plane level. shows a list of services provided to the BS through backbone network. Some of these services may be provided by other means (highlighted).

Table C1—Backbone Network Services

Service	Possible methods for providing service	Comments
Backhaul for traffic	-	Transport protocol is not specified
Provide a BS with the identity of its neighbors	Get info from ASA server Configuration (network management)	Options (1) and (2) are really the same, the only difference is where the configuration is done
Provide a BS with the identity of the ASA server	ASA server publishes its presence Configuration (network management)	Message format and transport protocol need to be specified for interoperability
Advertise the fact that a certain MSS has registered with a certain BS	BS notifies ASA server BS notifies neighbor BS	Message format and transport protocol need to be specified for interoperability
Provide a BS information about a certain MSS	ASA server provides information Serving BS provides information (or network management if serving BS cannot be found)	Message format and transport protocol need to be specified for interoperability
Information exchange during HO	ASA server is in the middle BS to BS direct exchange	Message format and transport protocol need to be specified for interoperability

As evident from , it is possible to exchange information between BS directly or through the ASA server. In that respect the protocol used for information exchange on the backbone can regard the ASA server as another BS, and therefore no special message will be required with regards to the ASA server.

C.2 Backbone network communication primitives

The primitives described in this section may be used for communication with peer BS or with an ASA server through the backbone.

C.2.1 I-am-host-of message

This message is sent by a BS to notify other BS (or the ASA server) that a certain MSS is registered with it. The message shall be sent upon MSS registration, and periodically (TBD period). The message might trigger

a neighbor BS to request more information on the MSS (either directly from the sender BS, or from the ASA server). The message contains the following information,

Table C2—I-am-host-of Message

Field	Size	Notes
Message Type = ?	8-bit	
Sender BS-ID	48-bit	Base station unique identifier (Same number as that broadcasted on the DL-MAP message)
Target BS-ID	48-bit	Base station unique identifier (Same number as that broadcasted on the DL-MAP message)
Time Stamp	32-bit	Number of milliseconds since midnight GMT (set to 0xffffffff to ignore)
Num Records	16-bit	Number of MSS identity records
For (j=0; j<Num Records; j++) {		
MSS unique identifier	48-bit	48-bit unique identifier used by MSS on initial network entry
}		
Security field	TBD	A means to authenticate this message
CRC field	32-bit	IEEE CRC-32

C.2.2 MSS-info-request message

This message may be sent from one BS to another (or to the ASA server) to request information about an MSS. Typically the message will be sent as a reaction to reception of an *I-am-host-of* message, or in cases where an MSS is trying to re-enter the network after a HO. The message contains the following information,

Table C3—MSS-info-request Message

Field	Size	Notes
Message Type = ?	8-bit	
Sender BS-ID	48-bit	Base station unique identifier (Same number as that broadcasted on the DL-MAP message)
Target BS-ID	48-bit	Base station unique identifier (Same number as that broadcasted on the DL-MAP message)
Time Stamp	32-bit	Number of milliseconds since midnight GMT (set to 0xffffffff to ignore)
Num Records	16-bit	Number of MSS identity records
For (j=0; j<Num Records; j++) {		
MSS unique identifier	48-bit	48-bit unique identifier used by MSS (as provided by the MSS or by the <i>I-am-host-of</i> message)
}		

Security field	TBD	A means to authenticate this message
CRC field	32-bit	IEEE CRC-32

C.2.3 MSS-info-response message

This message may be sent from one BS to another (or from the ASA server) to provide information about an MSS. Typically the message will be sent in response to an *MSS-info-request* message. The message contains the following information,

Table C4—MSS-info-response Message

Field	Size	Notes
Message Type = ?	8-bit	
Sender BS-ID	48-bit	Base station unique identifier (Same number as that broadcasted on the DL-MAP message)
Target BS-ID	48-bit	Base station unique identifier (Same number as that broadcasted on the DL-MAP message)
Time Stamp	32-bit	Number of milliseconds since midnight GMT (set to 0xffffffff to ignore)
Num Records	16-bit	Number of MSS identity records
For (j=0; j<Num Records; j++) {		
MSS unique identifier	48-bit	48-bit unique identifier used by MSS (as provided by the MSS or by the <i>I-am-host-of</i> message)
N_NSIE		Number of Network Service Information Elements
For (k=0; k<N_NSIE; k++) {		
Field Size	16-bit	Size of TLV encoded information field below
TLV encoded information	Variable	TLV information as allowed on a DSA-REQ MAC message
}		
N_SAIE		Number of Security Association Information Elements
For (k=0; k<N_SAIE; k++) {		
Field Size	16-bit	Size of TLV encoded information field below
TLV encoded information	Variable	TLV information as allowed on a PKM-xxx MAC messages
}		
Field Size	16-bit	Size of TLV encoded information field below
TLV encoded information	Variable	TLV information as allowed on a SBC-REQ MAC message
}		
Security field	TBD	A means to authenticate this message
CRC field	32-bit	IEEE CRC-32

C.2.4 HO-notification message

This message is sent by a BS to advertise an MSS intention to perform HO. The message is typically sent to neighbor BS to be referred in BSHO-REQ message or MSSHO-REQ message. The message serves to alert the target base stations that a HO event is going to happen. The message contains the following information,

Table C5—HO-notification Message

Field	Size	Notes
Message Type = ?	8-bit	
Sender BS-ID	48-bit	Base station unique identifier (Same number as that broadcasted on the DL-MAP message)
Target BS-ID	48-bit	Base station unique identifier (Same number as that broadcasted on the DL-MAP message)
Time Stamp	32-bit	Number of milliseconds since midnight GMT (set to 0xffffffff to ignore)
Num Records	16-bit	Number of MSS identity records
For (j=0; j<Num Records; j++) {		
MSS unique identifier	48-bit	48-bit unique identifier used by MSS (as provided by the MSS or by the <i>I-am-host-of</i> message)
Estimated Time to HO	16-bit	In milliseconds, relative to the time stamp, value 0 of this parameter indicates that no actual HO is pending
Required BW	8-bit	Bandwith which is required by MSS (to gurarantee minimum packet data transmission)
Required OoS	8-bit	Quality of Service level — Unsolicited Grant Service (UGS) — Real-time Polling Service (rtPS) — Non-real-time Polling Service (nrtPS) — Best Effort Service (BE)
}		
Security field	TBD	A means to authenticate this message
CRC field	32-bit	IEEE CRC-32

C.2.5 HO-notification-response message

This message is sent from one BS to another BS, typically in response to a *HO-notification* message. The message serves to provide the BS that sent the *HO-notification* message with information about the level of service the MSS could expect if it transitions to this BS. The message contains the following information,

Table C6—HO-notification-response Message

Field	Size	Notes
Message Type = ?	8-bit	
Sender BS-ID	48-bit	Base station unique identifier (Same number as that broadcasted on the DL-MAP message)
Target BS-ID	48-bit	Base station unique identifier (Same number as that broadcasted on the DL-MAP message)
Time Stamp	32-bit	Number of milliseconds since midnight GMT (set to 0xffffffff to ignore)
Num Records	16-bit	Number of MSS identity records
For (j=0; j<Num Records; j++) {		
MSS unique identifier	48-bit	48-bit unique identifier used by MSS (as provided by the MSS or by the <i>I-am-host-of</i> message)
QoS Estimated	8-bit	Bandwidth which is provided by BS (to guarantee minimum packet data transmission) TBD how to set this field
BW Estimated	8-bit	Quality of Service level — Unsolicited Grant Service (UGS) — Real-time Polling Service (rtPS) — Non-real-time Polling Service (nrtPS) — Best Effort
ACK/NACK	1-bit	Acknowledgement or Negative acknowledgement — 1 is Acknowledgement which means that the neighbor BS accepts the HO-notification message from the serving BS — 0 is Negative acknowledgement which means that the neighbor BS may not accept the HO-notification message from the serving BS
}		
Security field	TBD	A means to authenticate this message
CRC field	32-bit	IEEE CRC-32

C.2.6 HO-notification-confirm message

This message is sent from one BS to another BS, typically in response to an *HO-notification-response* message. The message serves to provide the BS that sent the *HO-notification-response* message with information about the level of service and capability. The message contains the following information:

Table C7—HO-notification Message

Field	Size	Notes
Message Type = ?	8-bit	
Sender BS-ID	48-bit	Base station unique identifier (Same number as that broadcasted on the DL-MAP message)

1	Target BS-ID	48-bit	Base station unique identifier (Same number as that broadcasted on the DL-MAP message)
2			
3	Time Stamp	32-bit	Number of milliseconds since midnight GMT (set to 0xffffffff to ignore)
4			
5	Num Records	16-bit	Number of MSS identity records
6			
7	For (j=0; j<Num Records; j++) {		
8			
9	MSS unique identifier	48-bit	48-bit universal MAC address of the MSS (as provided to the BS on the RNG-REQ message)
10			
11	QoS Estimated	8-bit	Bandwidth which is provided by BS (to guarantee minimum packet data transmission) TBD how to set this field
12			
13	BW Estimated	8-bit	Quality of Service level
14			— Unsolicited Grant Service (UGS)
15			— Real-time Polling Service (rtPS)
16			— Non-real-time Polling Service (nrtPS)
17			— Best Effort Service (BE)
18			
19			
20			
21			
22			
23	}		
24			
25	Security field	TBD	A means to authenticate this message
26			
27	CRC field	32-bit	IEEE CRC-32
28			
29			
30			
31			
32			

C.2.7 Example of Backbone Network HO procedure

Figure C.1—Example of HO call flow by MS

1
2
3
4
5
6
7
8
9
10
11
12
13
14
15
16
17
18
19
20
21
22
23
24
25
26
27
28
29
30
31
32
33
34
35
36
37
38
39
40
41
42
43
44
45
46
47
48
49
50
51
52
53
54
55
56
57
58
59
60
61
62
63
64
65

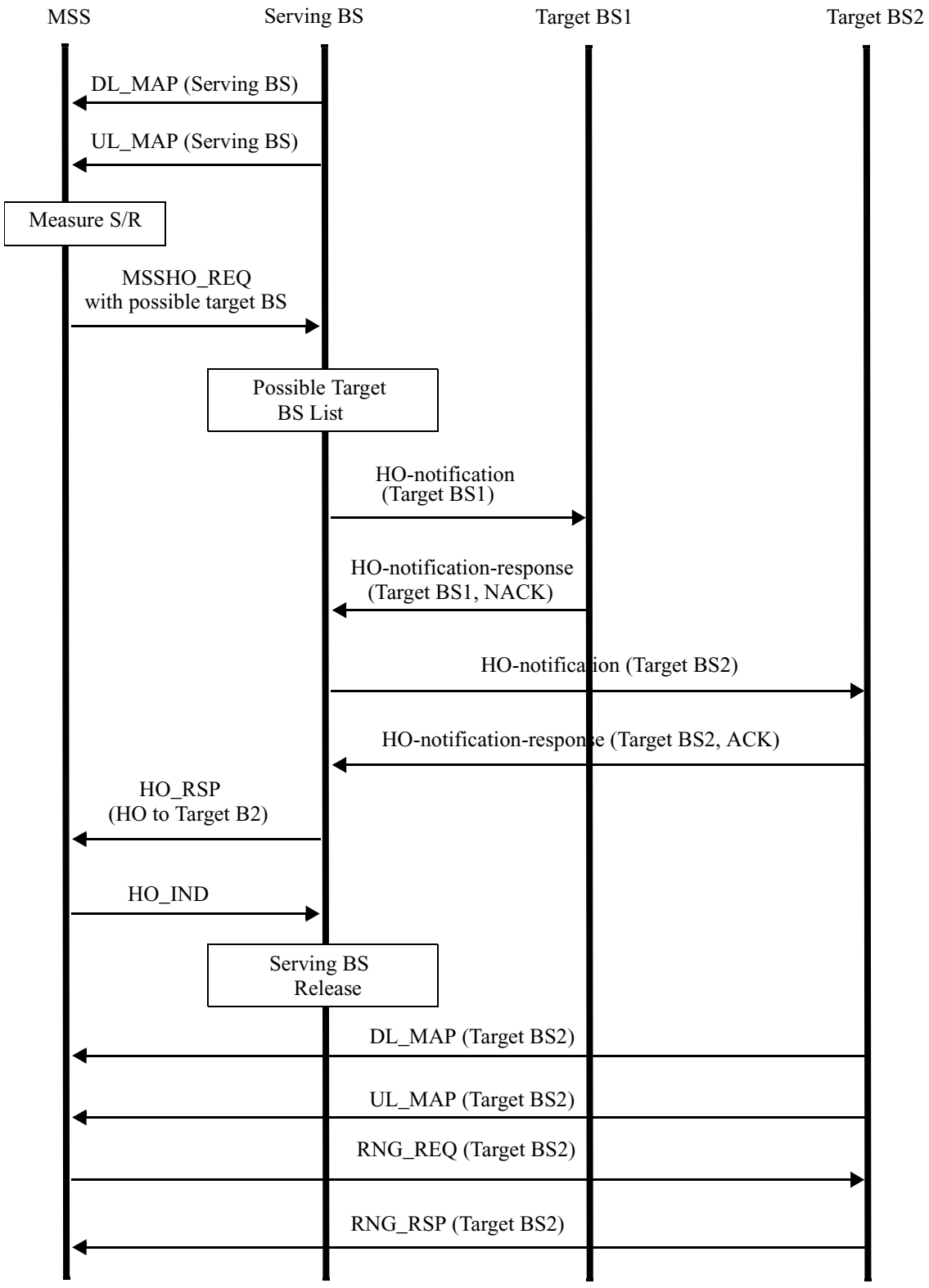
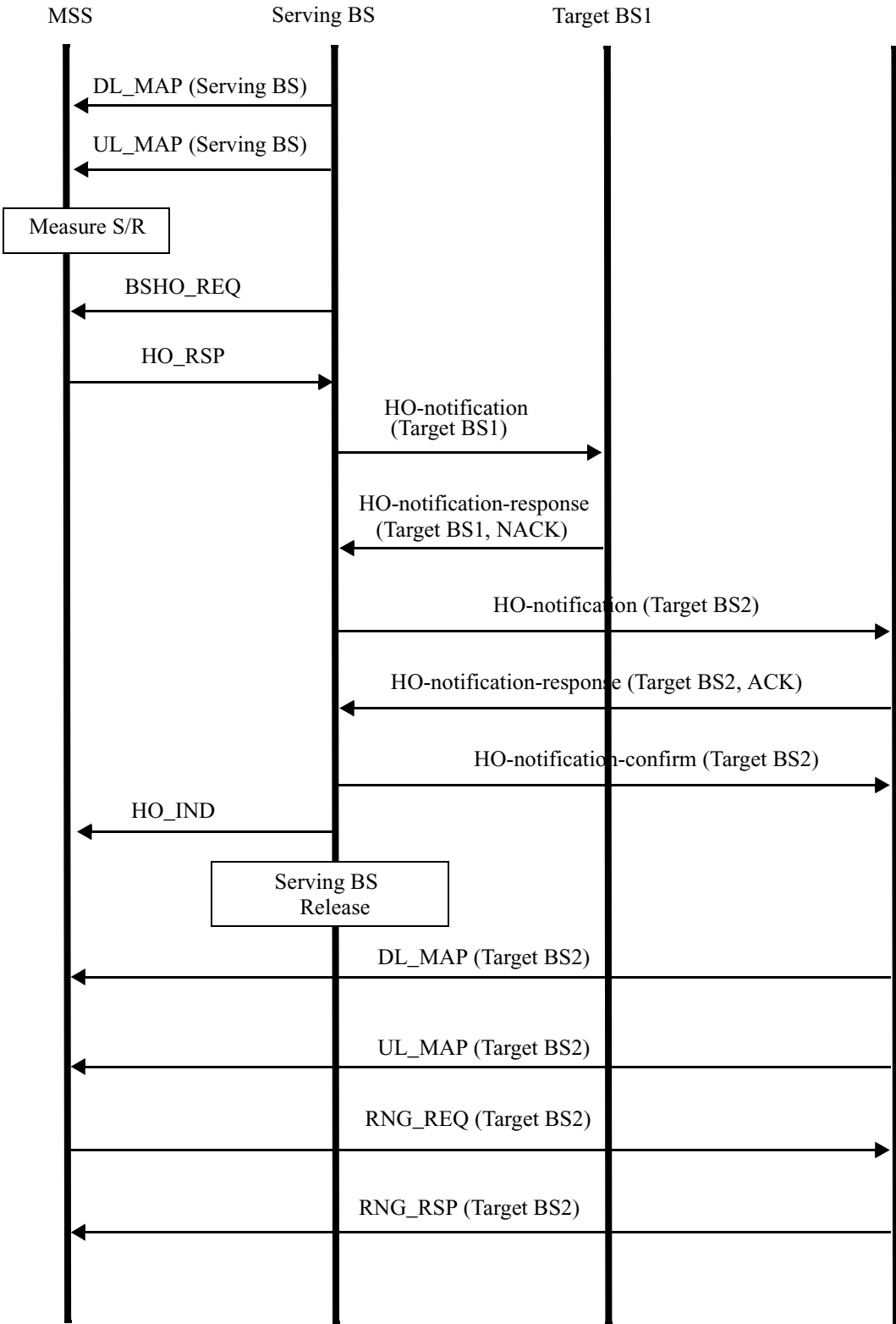

Figure C.2—Example of HO call flow by BS

1
2
3
4
5
6
7
8
9
10
11
12
13
14
15
16
17
18
19
20
21
22
23
24
25
26
27
28
29
30
31
32
33
34
35
36
37
38
39
40
41
42
43
44
45
46
47
48
49
50
51
52
53
54
55
56
57
58
59
60
61
62
63
64
65



C.3 Backbone network communication protocol

TBD

C.4 Convergence sub-layer HO procedures

C.4.1 Supported convergence sub-layers

[This section should discuss the types of convergence sub-layer that are supported (i.e. IPv4, IPv6, Ethernet, or others)]

C.4.2 SAP for higher layer protocols

This section defines the services between the MAC and higher layers for supporting the HO process. In some scenarios the higher layers may use information provided by the MAC layer HO process to optimize their HO process and reduce the overall HO duration.

The information is defined as set of messages sent by the MAC layer to the higher layers, providing indication of particular events before and after MAC layer HO.

C.4.2.1 MSS Movement

Occurs at the MSS, indication that the MSS has registered to a new Target BS.

C.4.2.2 Serving BS Pre-HO

Occurs at the Serving BS, indication that a MAC layer HO of a certain MSS is about to take place.

C.4.2.3 Target BS Pre-Ho

Occurs at the Target BS, indication that a MAC layer HO of a certain MSS is about to take place.

C.4.2.4 BS Post-HO

Occurs at the Target BS or MSS, indication that a MAC layer HO between the MSS and the Target BS has been completed.

C.4.2.5 Serving BS-Link Loss

Occurs at the Serving BS, indication that MAC layer link between the Serving BS and a certain MSS has been lost.