

The Impact of SC-FDMA on UL SDMA

Document Number: IEEE C802.16m-08/137r2

Date Submitted: 2008-03-11

Source:

Michael Erlihson, Doron Ezri, Oded Redlich, Shimi Shilo, Mark Geles, Roy Maiberger michaele@runcom.co.il
Runcom Technologies
Moshe Levi St. 11,
Rishon LeZion 75658, Israel

Re:

TGm Uplink multiple access rapporteur chairs' report.

Purpose:

To discuss the impact of SC-FDMA on UL SDMA.

Notice:

This document does not represent the agreed views of the IEEE 802.16 Working Group or any of its subgroups. It represents only the views of the participants listed in the "Source(s)" field above. It is offered as a basis for discussion. It is not binding on the contributor(s), who reserve(s) the right to add, amend or withdraw material contained herein.

Release:

The contributor grants a free, irrevocable license to the IEEE to incorporate material contained in this contribution, and any modifications thereof, in the creation of an IEEE Standards publication; to copyright in the IEEE's name any IEEE Standards publication even though it may include portions of this contribution; and at the IEEE's sole discretion to permit others to reproduce in whole or in part the resulting IEEE Standards publication. The contributor also acknowledges and accepts that this contribution may be made public by IEEE 802.16.

Patent Policy:

The contributor is familiar with the IEEE-SA Patent Policy and Procedures:

<<http://standards.ieee.org/guides/bylaws/sect6-7.html#6>> and <<http://standards.ieee.org/guides/opman/sect6.html#6.3>>.

Further information is located at <<http://standards.ieee.org/board/pat/pat-material.html>> and <<http://standards.ieee.org/board/pat>>.

Introduction

- SC-FDMA has been recently proposed by some companies as an alternative to OFDMA for the UL of 802.16m, due to roughly 2dB lower PAPR (in the time domain).
- However, in spatial multiplexing (SM), SC-FDMA makes ML decoding impractical, and one has to resort to very suboptimal decoders such as ZF or MMSE.

Introduction – cont.

- The degradation inflicted by suboptimal decoding in the case of Collaborative MIMO with 2 Rx antennas at the BS was investigated in [C80216m-08_045] and [UL MA_ link performance result_revised_LGE].
- Here we consider the case of 4×4 UL SDMA, in which the degradation due to SC-FDMA is significantly larger (about 10dB worse than OFDMA).

MIMO in OFDMA

- Block diagram for MIMO in OFDMA:

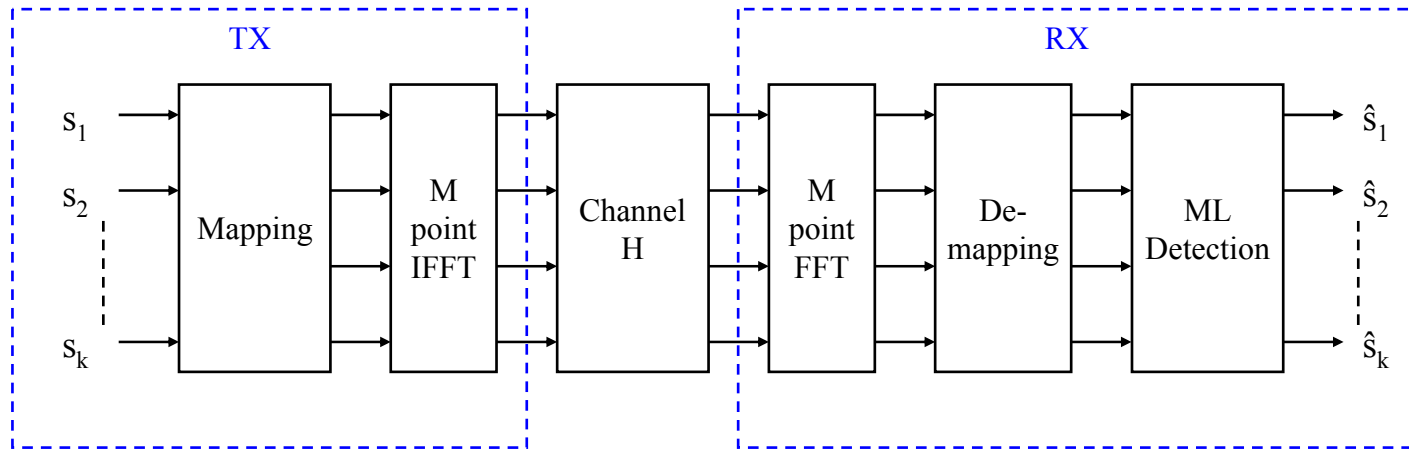

- After FFT, each subcarrier can be written as:

$$\mathbf{y} = \mathbf{H}\mathbf{s} + \text{noise}$$

where $\mathbf{s} \in \text{QAM}^k$.

- In a 4 x 4 scenario, this would require a search over $\{\text{constellation size}\}^4$.

MIMO in SC-FDMA

- Block diagram for MIMO in SC-FDMA:

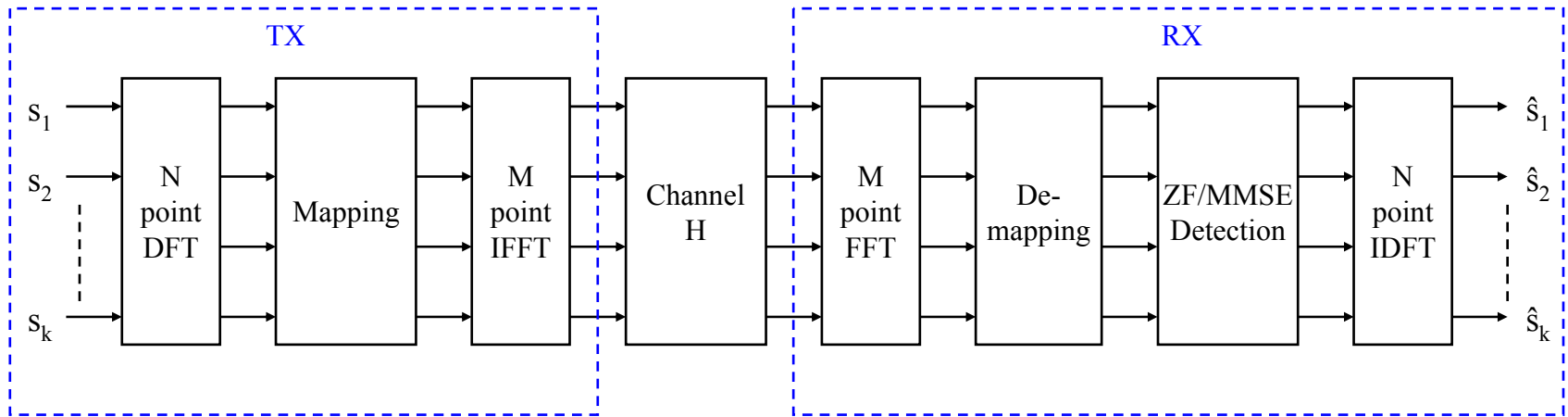

- After FFT, each subcarrier can be written as:

$$\mathbf{y} = \mathbf{H}\mathbf{x} + \text{noise}$$

where \mathbf{x} is a combination of kN symbols (DFT result).

- In a 4×4 scenario, this would require a search over $\{\text{constellation size}\}^{4N}$ – too much for ML!!!

MIMO in SC-FDMA – cont.

- The high search complexity requires simplified sub-optimal algorithms, such as Zero Forcing or MMSE.
- Higher performance sub-optimal schemes such as DFE impose a very high complexity.

Some Analytical Background

- Let us look at the Diversity Order and Array Gain of MMSE vs. that of ML, for M transmit & N receive antennas:

	Diversity Order	Array Gain
ML	N	$N-M+1$
MMSE	N/M	$(N-M+1)/M$

- In a 4×4 scenario, the difference is 6dB in array gain + 4th order diversity which amounts to roughly 10dB at $\text{PER} = 10^{-1}$

Simulation Results

- We compare the performance of 4x4 UL SDMA with ML (OFDMA) and MMSE (SC-FDMA) detectors with the following assumptions:
 - Ped-B 3km/h.
 - Uncorrelated channels.
 - QPSK rate $\frac{1}{2}$ with CTC.
 - Perfect channel knowledge.
 - FEC Block Size = 480 bits.

Simulation Results – cont.

Bit Error Rate for OFDMA (ML) vs. SC-FDMA (MMSE)

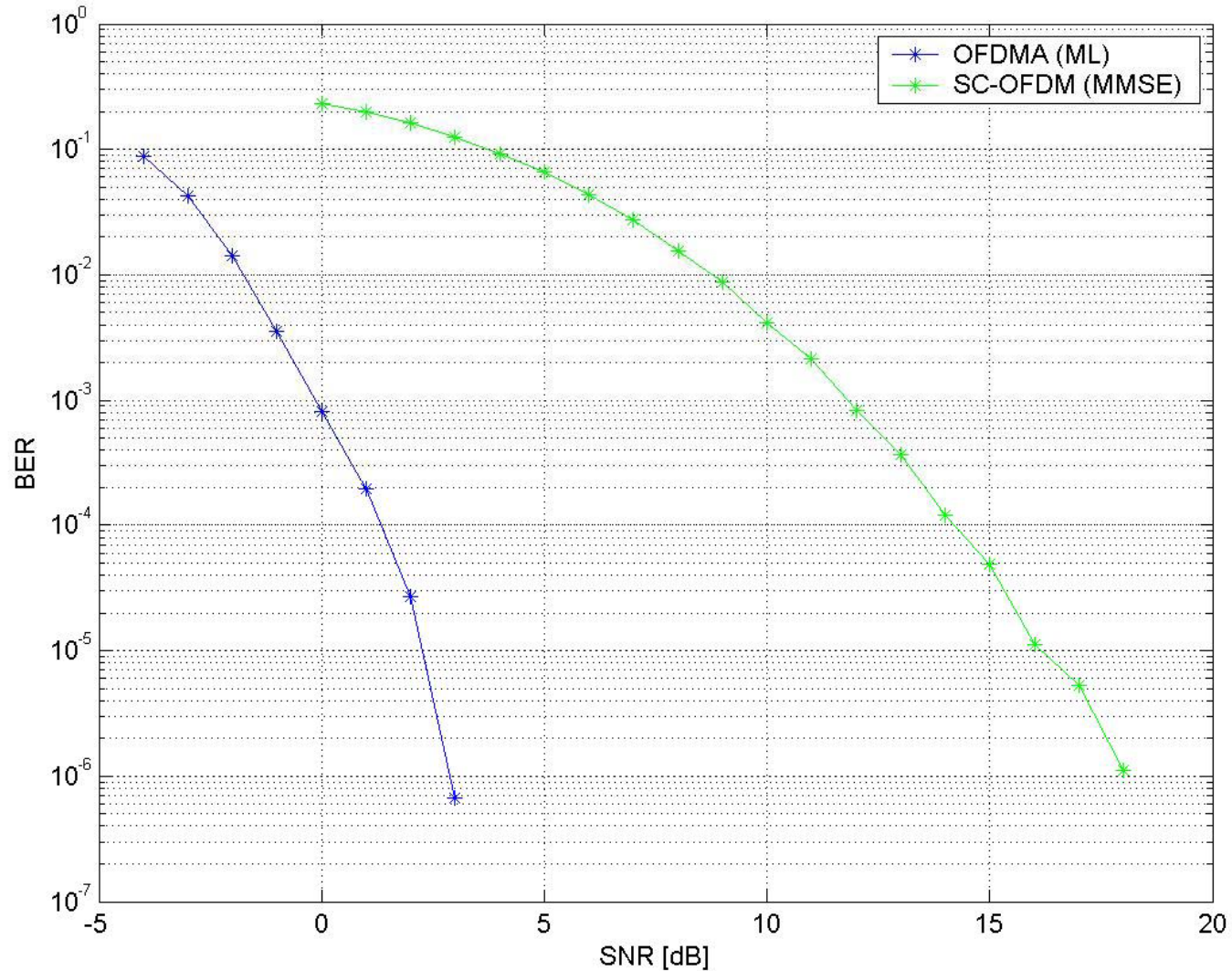

Simulation Results – cont.

Block Error Rate for OFDMA (ML) vs. SC-FDMA (MMSE)

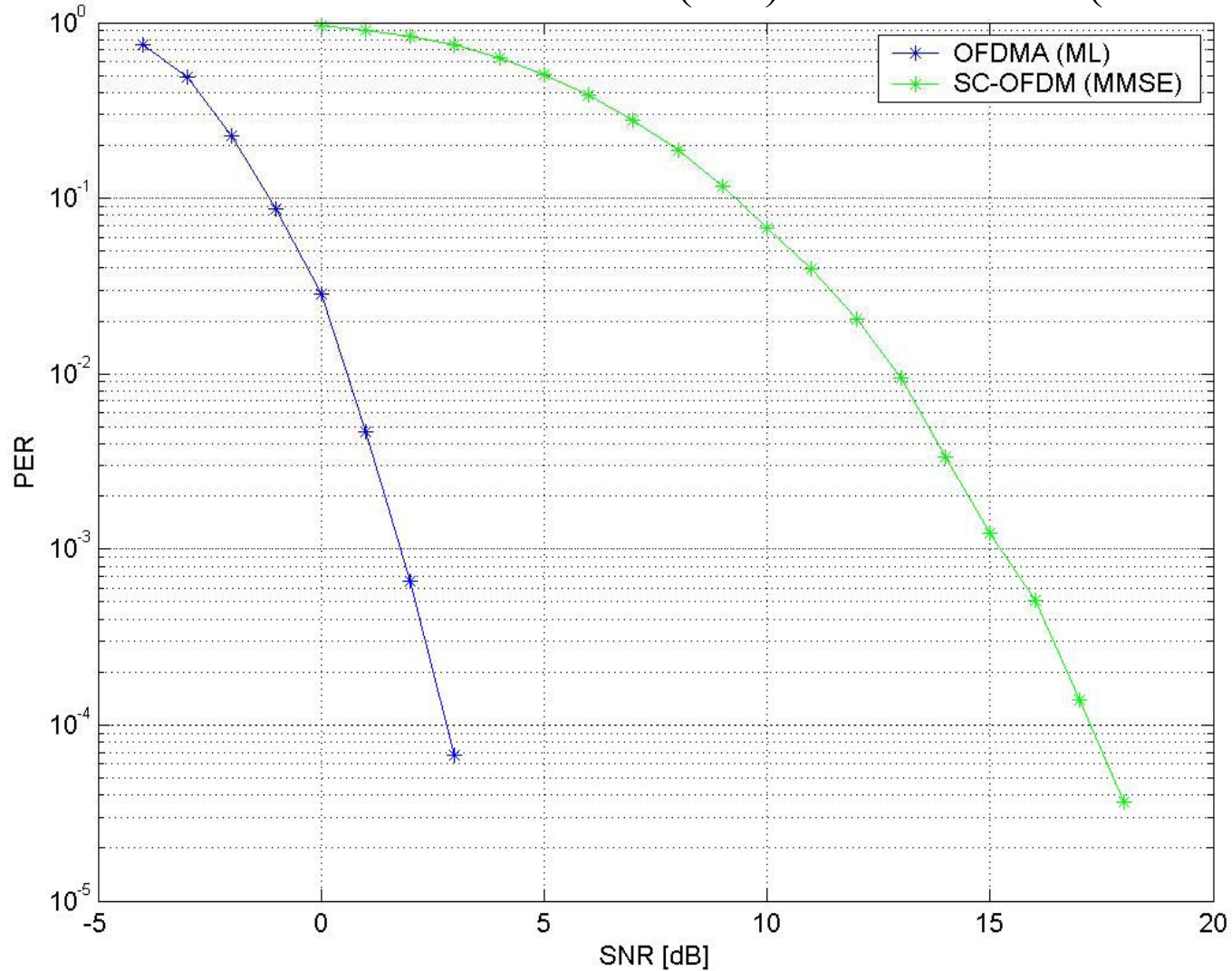

Conclusions

- At $\text{PER} = 10^{-1}$ there is a 10dB gap between SC-FDMA (MMSE) & OFDMA (ML)
- Taking SC-FDMA's 2dB lower PAPR into account, OFDMA still has an 8dB advantage
- Even when assuming a realistic near optimal ML scheme for OFDMA (decreasing performance by $\sim 2\text{dB}$) and a better performing scheme for SC-FDMA, there is still a large gap in favor of OFDMA!

Conclusions – cont.

- If 16m considers PAPR reduction as an important issue, plenty of alternatives are available: SLM, TR, XNN technology, etc.
- These schemes reduce the PAPR without compromising the UL SDMA performance.
- Having taken into account the UL SDMA performance degradation caused by SC-FDMA, we conclude that OFDMA should be used as the UL transmission scheme.