

Design of Resource Allocation Unit Structure for IEEE 802.16m

IEEE 802.16 Presentation Submission Template (Rev. 9)

Document Number:

IEEE C802.16m-08/188r3

Date Submitted:

2008-03-10

Source:

Taeyoung Kim, Jeongho Park, Junsung Lim, Jaeweon Cho, David Mazzaresse
Hoky Choi, Jaehee Cho, Heewon Kang, Yungsoo Kim, DS Park
Samsung Electronics Co., Ltd.
416 Maetan-3, Suwon, 443-770, Korea

Voice: +82-31-279-0202
E-mail: ty33.kim@samsung.com

Venue:

IEEE 802.16m-08/005, "Call for Contributions on Project 802.16m System Description Document (SDD)".
Target topic: "Downlink Physical Resource Allocation Unit", "Pilot Structures as relevant to downlink MIMO".

Base Contribution:

None

Purpose:

To be discussed and adopted by TGM for the 802.16m SDD

Notice:

This document does not represent the agreed views of the IEEE 802.16 Working Group or any of its subgroups. It represents only the views of the participants listed in the "Source(s)" field above. It is offered as a basis for discussion. It is not binding on the contributor(s), who reserve(s) the right to add, amend or withdraw material contained herein.

Release:

The contributor grants a free, irrevocable license to the IEEE to incorporate material contained in this contribution, and any modifications thereof, in the creation of an IEEE Standards publication; to copyright in the IEEE's name any IEEE Standards publication even though it may include portions of this contribution; and at the IEEE's sole discretion to permit others to reproduce in whole or in part the resulting IEEE Standards publication. The contributor also acknowledges and accepts that this contribution may be made public by IEEE 802.16.

Patent Policy:

The contributor is familiar with the IEEE-SA Patent Policy and Procedures:

<<http://standards.ieee.org/guides/bylaws/sect6-7.html#6>> and <<http://standards.ieee.org/guides/opman/sect6.html#6.3>>.

Further information is located at <<http://standards.ieee.org/board/pat/pat-material.html>> and <<http://standards.ieee.org/board/pat>>.

Outline

- Scope and Goal
- Requirements
- Rationale
- DL Resource Allocation Unit Design
- Proposed RU structure
- Proposed DL Subchannelization
- Proposed DL reference signal
- Proposed text for SDD
- Annex A, B

Scope and Goal

- Scope
 - This contribution is about symbol and pilot structure.
 - It is desirable to determine symbol and pilot structure considering each other based on various requirements and physical functionalities
- Goal
 - To Propose Integrated Symbol and Pilot Structure which is viable to support physical functionalities and to meet requirements

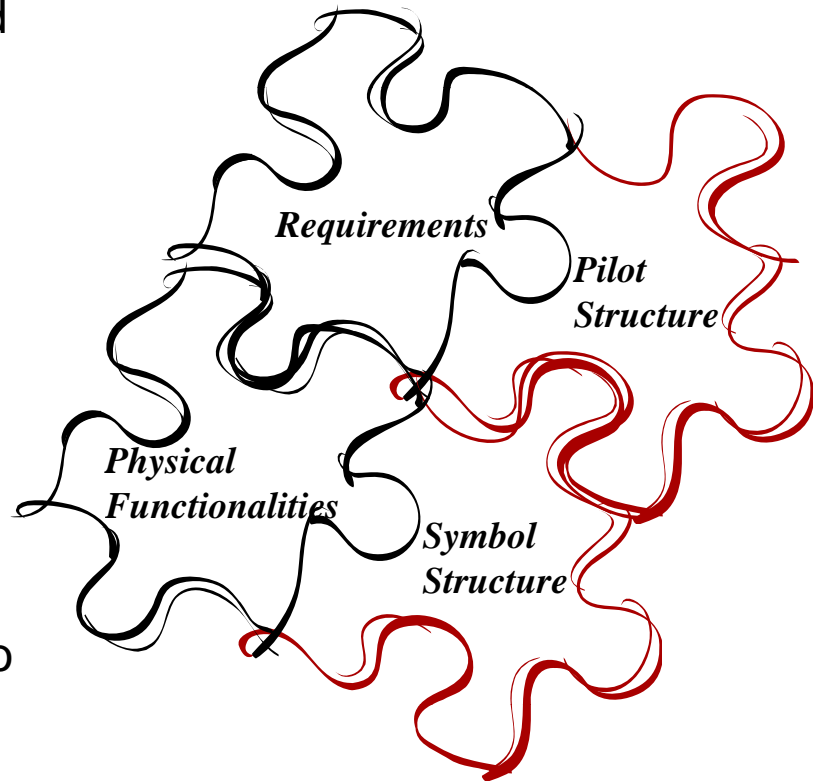

Requirements for RU Structure

- Frame and Subframe Structure

- Hierarchical frame structure
(Refer to C802.16m-08/118r1)

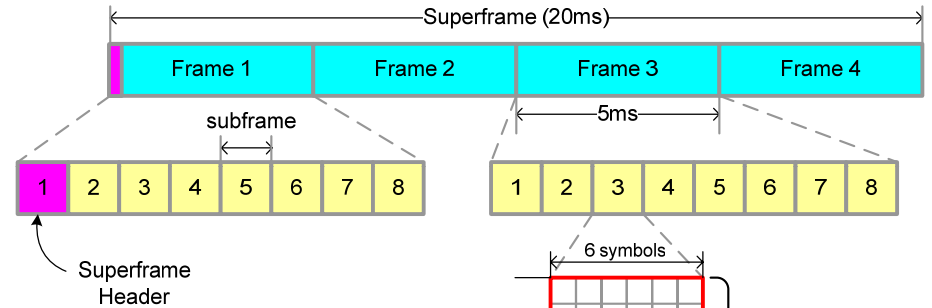

- Requirements for Resource allocation Unit (RU)

- To support band selection and diversity RU in FDM
(Refer to C802.16m-08/187 for further details)
- To support OL/CL-MIMO with different ant. configure

- Requirements for Pilot Structure

- Pilot overhead : $< 17.0\%$ for 2Tx, $< 22.2\%$ for 4Tx
(Refer to Annex A for further details)
- Adjacent pilot distance : < 4 tones & < 6 symbols
(Refer to Annex B for further details)

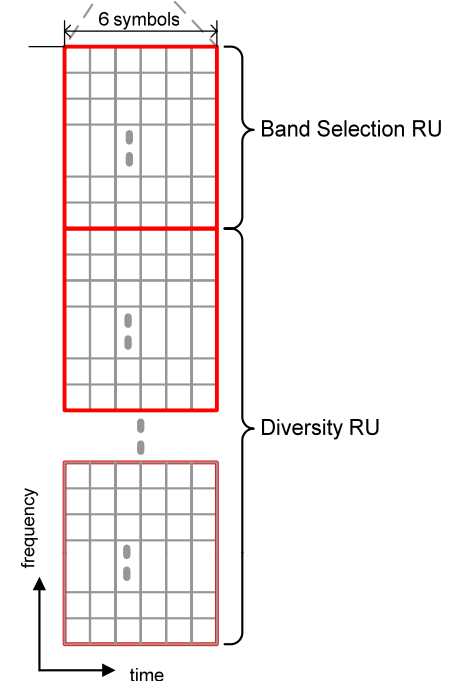

Rationale for RU Structure (1/3)

- Categorize subchannelization in terms of *pilot type* and the *size of a block* for a RU
 - A block is defined as a physically contiguous group of X subcarriers by Y symbols.
 - Pilot type: common pilot vs. dedicated pilot
 - Block size: large vs. small (even including a tone)

	Large block	Small block
Common		necessary
Dedicated		?

- Necessity for Small Block
 - To support small packet with full frequency diversity gain
 - such as DL control channel (including MAP), TCP ACK, VoIP
- Why NOT Dedicated Pilot for Small Block?
 - Inefficiency to incorporate a number of pilots within a small block
 - Low channel estimation performance due to restriction of pilot number

The support of *Small Block with Common pilot* should be mandatory for reliable transmission of essential DL control signal

Rationale for RU Structure (2/3)

- Necessity for Large Block
 - Efficient to support band selection subchannel (e.g. AMC in legacy system)
 - Efficient to utilize CL-MIMO (e.g. Precoding, Beamforming)
 - Eligible to contain sufficient number of pilots within one block
- Which Type of Pilot is more Suitable to Large Block ?
 - Case I : Large block with common + mandatory
 - Case II : Large block with dedicated + mandatory

	Large Block	Small Block
Common	case I	mandatory
Dedicated	case II	

Note that Large Block doesn't preclude to be used as diversity resource allocation unit

Rationale for RU Structure (3/3)

- Comparative Analysis

		Case I	Case II
Utilization of common pilot on channel estimation		High	Mediocre
Overhead	Need of BF/code book index indication	Yes	No
	Burden for 4Tx pilots	High	Low
	Additional common pilot/midamble for CQI/PMI	No	Yes
	Need of De-boosting power level indication for data ⁽¹⁾	Yes	No
Interference estimation accuracy		Low	High

⁽¹⁾: Assuming that MAP is multiplexed with data in FDM manner. Separate coding and power boosting is applied.
 See contribution IEEE C802.16m-08/185 for more details

Case II is more well-matched to *mandatory* compared to Case I.

We propose to use *small block with common pilot* and *large block with dedicated pilot* to effectively support for DL data traffic and control message.

DL Resource Allocation Unit Design

- Proposed Resource Allocation Unit (RU)
 - Size
 - 18 subcarriers x 6 OFDMA symbols (freq x time)
 - 108 subcarriers for data and pilot
 - Type
 - Diversity RU structure (large block and small block)
 - Band selection RU structure (large block only)
 - Large block has the size of 18 subcarriers and 6 symbols
- Pilot Patterns

	Block size	Pilot type	Total Pilot OH	Tx Ant.
Pilot Pattern A	Small	Common	11.1%	2 Tx
Pilot Pattern B	Large	Dedicated	11.1%	2 Tx
Pilot Pattern C (Low density)	Large	Dedicated	11.1%	4 Tx
Pilot Pattern D (High density)	Large	Dedicated	22.2%	4 Tx

Note that the pilot patterns is allowable to be changed for optimization

Proposed RU Structure (1/2)

- Pilot Pattern A

Parameter	Value
# of total usable subcarriers	864
# of RUs per subframe	24 @ 5MHz BW 48 @ 10MHz BW 96 @ 20MHz BW
# of data tones per RU	96
Pilot Type	<i>Common pilot</i>
Pilot OH per antenna	5.55 %

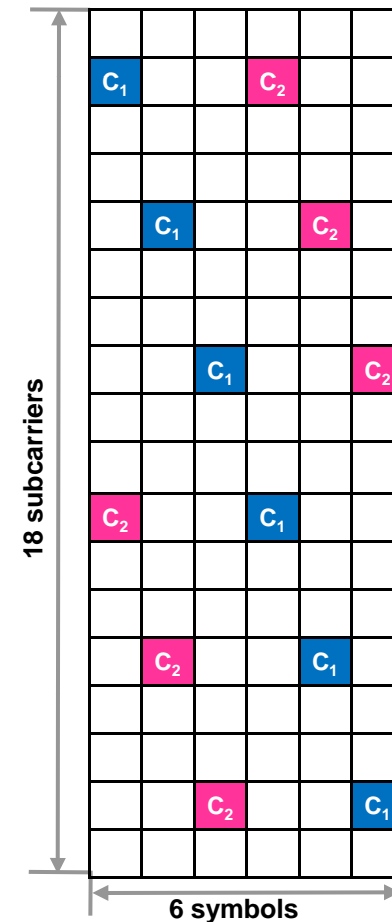

C_1 Antenna #1 C_2 Antenna #2

Proposed RU Structure (2/2)

- Pilot Pattern B:
 - Same as Pilot pattern A except that pilot type is dedicated one
- Pilot Pattern C, D:

Parameter		Value
# of total usable subcarriers		864
# of RUs per subframe		24 @ 5MHz BW 48 @ 10MHz BW 96 @ 20MHz BW
# of data tones per RU	Pilot pattern B, C	96
	Pilot pattern D	78
Pilot Type		<i>Dedicated pilot</i>
Pilot OH per antenna	Pilot pattern B	5.55 %
	Pilot pattern C	2.77 %
	Pilot pattern D	5.55 %

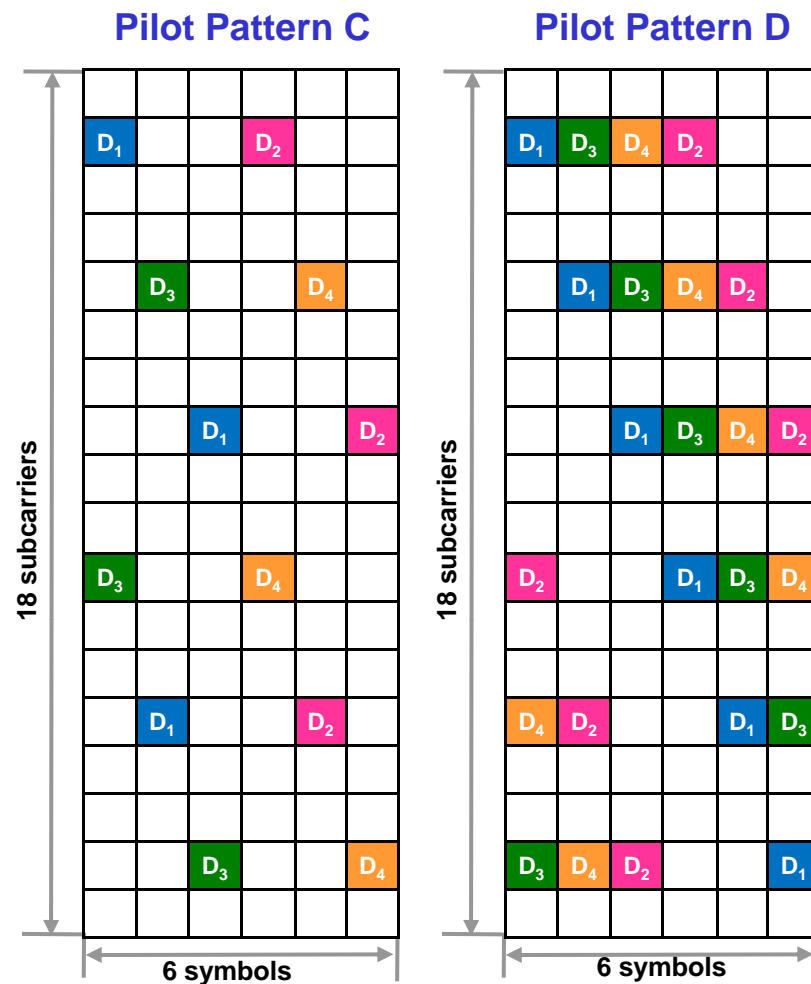

Overall Subchannelization Procedure

- Support
 - FFR of [Reuse 1, Reuse N] x FDM of [Diversity, Band selection]

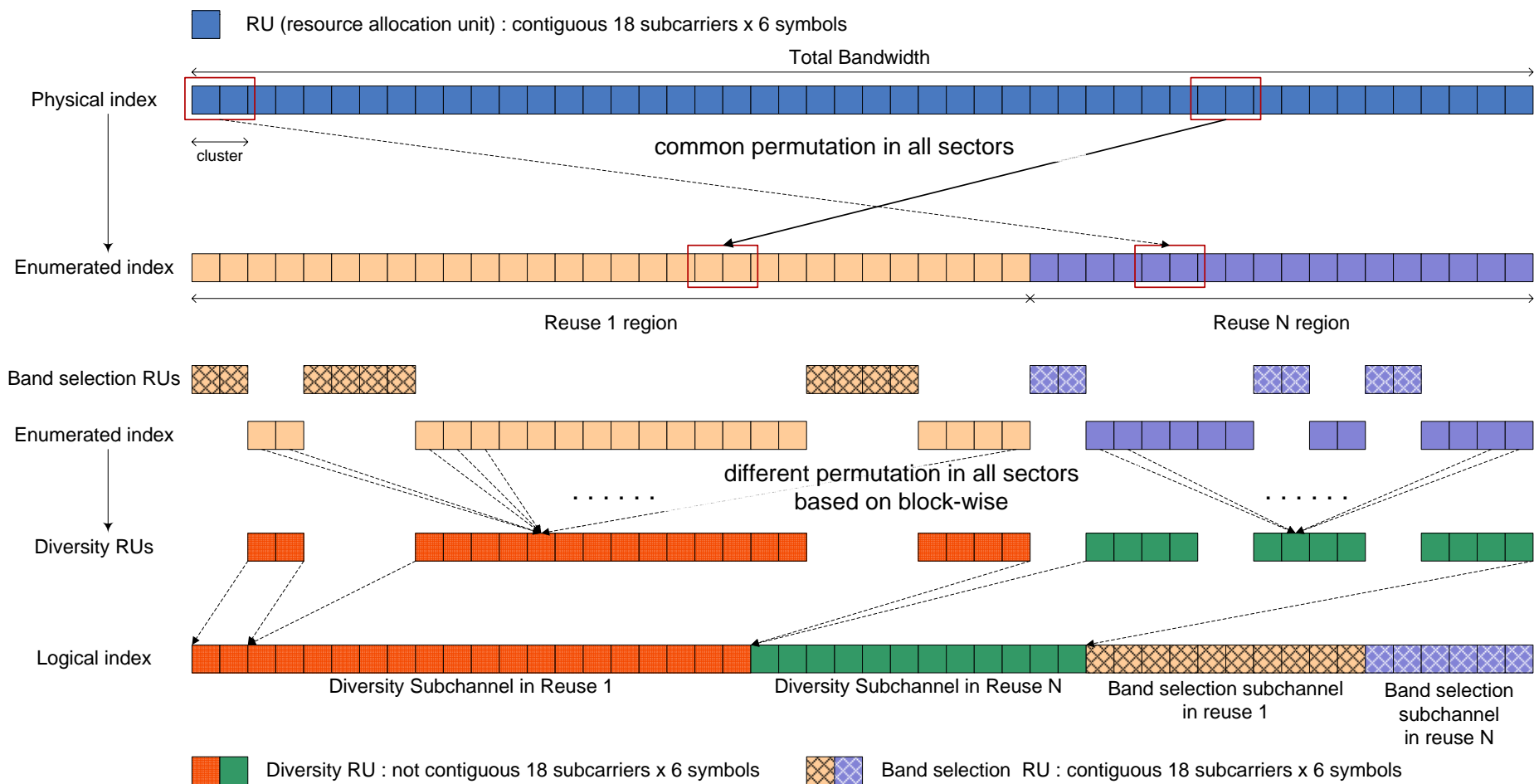

Diversity Subchannelization Procedure

- Example

- Diversity RU with small block

- Tone (ex. 1x1 block size) based permutation : MAP and small size packet
 - Mini-RU (ex. 6x6 block size) based permutation : DL control channel (e.g. ACK/NACK)

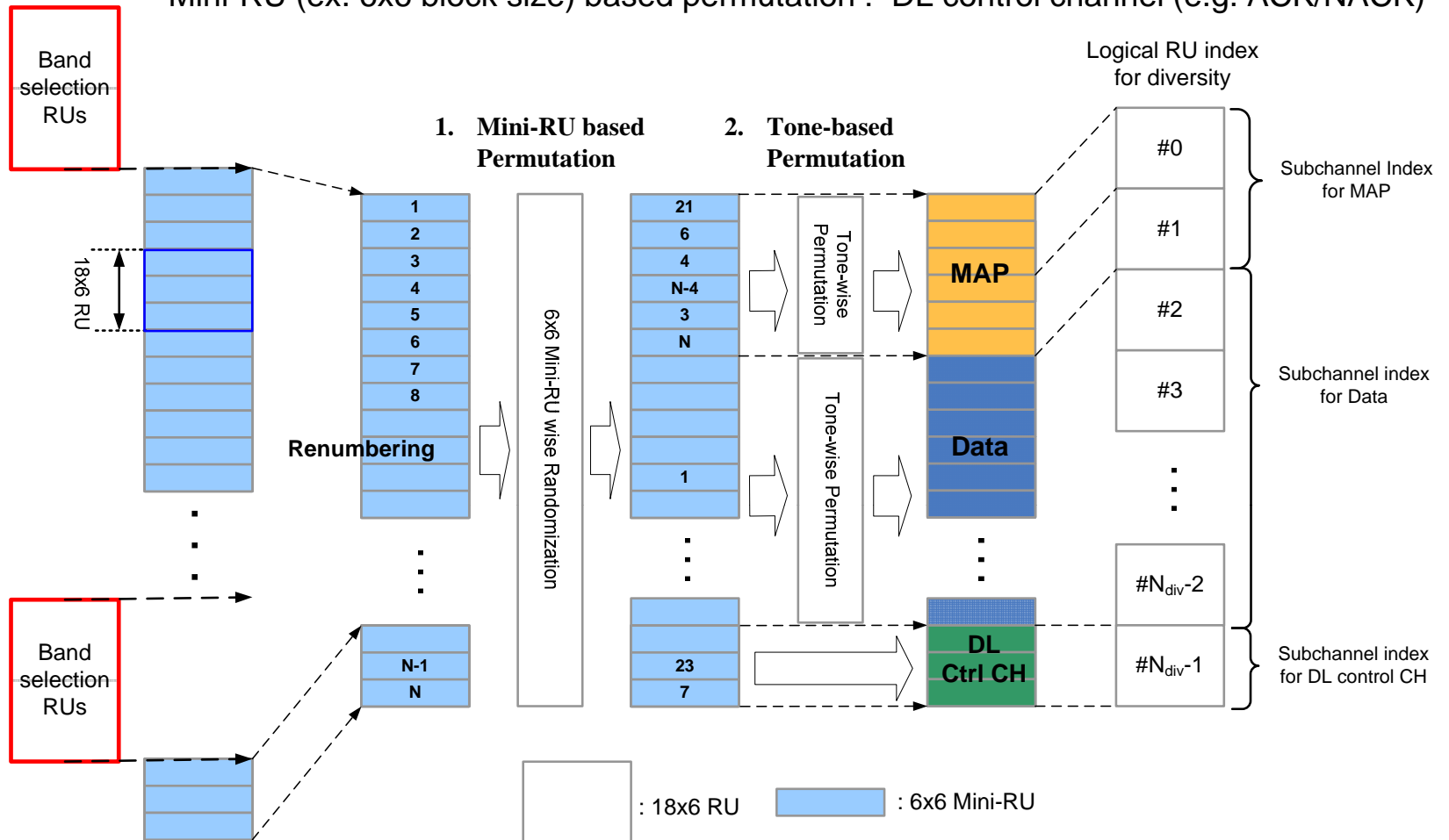

DL Reference Signal

- Transmission for CQI and PMI feedback
 - Periodicity: Once a frame (5ms)
 - Reference signal should be able to support maximum number of Tx stream.

- Example

- DL:UL = 5:3
- Pilot pattern C is not used in the subframe to which DL reference signal belongs

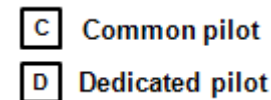
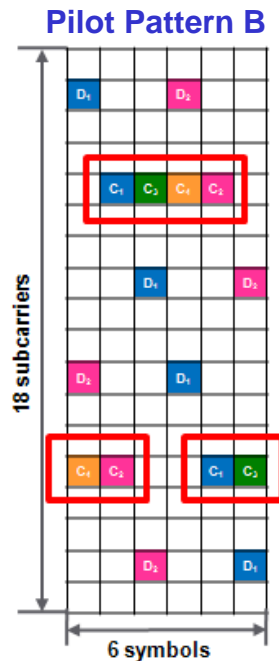
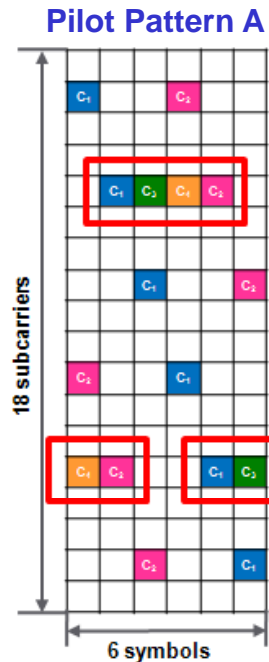
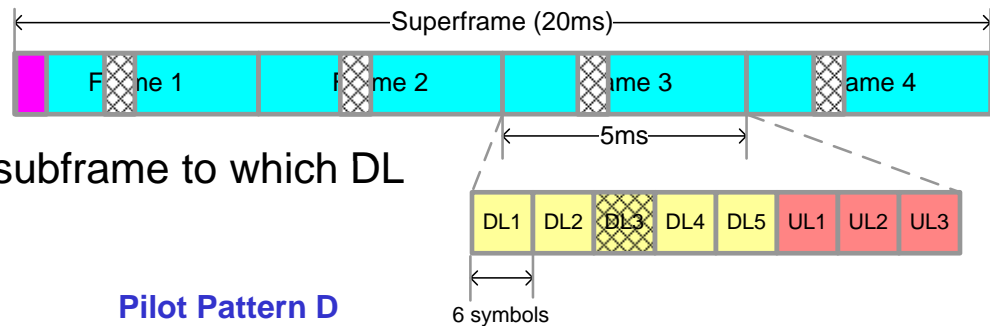

Summary

- Proposed Symbol and Pilot Structure

Multiplexing of diversity and band selection subchannel				FDM	
Resource allocation unit size				18 tones x 6 symbols	
DL Data	Diversity subchannel	Block size for permutation		Small (TBD)	Large (18 x 6)
		Pilot type		Common	Dedicated
		Pilot overhead per Ant.	2Tx	5.55%	5.55%
			4Tx	2.77%	Low : 2.77% High : 5.55%
	Band selection subchannel	Pilot type		Dedicated	
		Pilot overhead per Ant.	2Tx	5.55%	
	4Tx		Low : 2.77% High : 5.55%		
DL control	MAP	Block size for permutation		Small (TBD)	
	etc	Block size for permutation		Small (TBD)	
	Pilot type		Common		
Reference signal for CQI		Tx frequency		200Hz	
		Overhead		0.23% per Antenna	
Supportable physical functionality				FFR, OL/CL MIMO	

Proposed Text for SDD (1/3)

Insert the following text into SDD Section 11 in IEEE 802.16m-08/003

- Section 11.x: DL Symbol Structures

DL resource allocation unit (RU) should have the size of 18 contiguous or non-contiguous subcarriers and 6 symbols. Therefore, it should contain 108 subcarriers including data and pilot tones.

DL resource allocation unit (RU) should be composed of one block or multiple blocks. A block is physically contiguous group of X subcarriers by Y symbols.

The size of a block should be variable according to the type of resource allocation unit.

- Section 11.x: Diversity Resource Allocation Unit

Diversity RU should be composed of multiple blocks which are spread out whole frequency band.

- Section 11.x: Band Selection Resource Allocation Unit

Band selection RU should be a block which has the size of 18 subcarriers by 6 symbols.

Proposed Text for SDD (2/3)

- Section 11.x: DL Pilot Pattern

There are 4 pilot patterns according to pilot type and available number of transmit antennas.

Pattern A and B should be used for 2 transmit antennas. Pattern C and D should be used for 4 transmit antennas.

Pattern A should be used as the common pilot in diversity RU. Pattern B, C and D should be used as the dedicated pilot in diversity and band selection RU.

(Add figures of pilot patterns as following.)

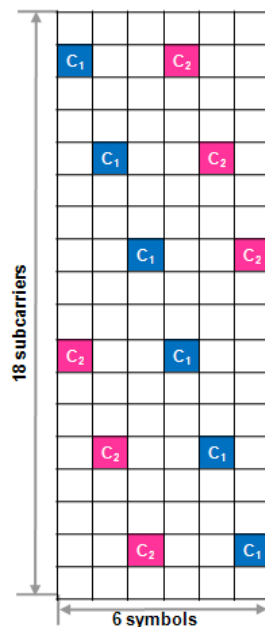

(a) Pilot Pattern A

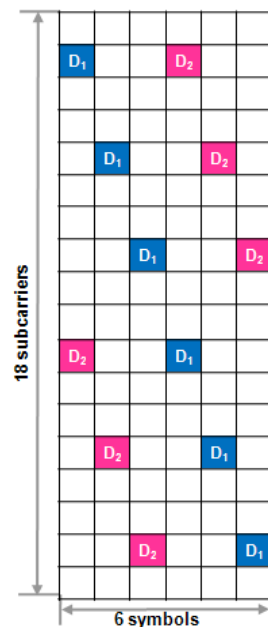

(b) Pilot Pattern B

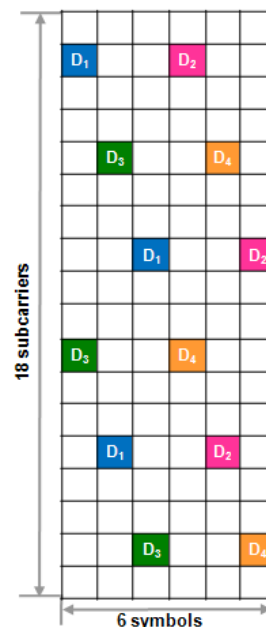

(c) Pilot Pattern C

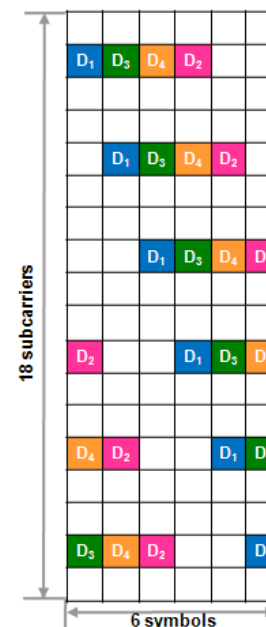

(d) Pilot Pattern D

■ D₁ Antenna #1
 ■ D₂ Antenna #2
 ■ D₃ Antenna #3
 ■ D₄ Antenna #4

Proposed Text for SDD (3/3)

- Section 11.x: DL Subcarrier Mapping to Resource Allocation Unit

Overall procedure of DL subcarrier mapping to RU should be like below :

1. Common permutation with cluster (A cluster is the multiples of a block with the size of 18 x 6)
2. Divide total clusters into reuse 1 region and reuse N region exclusively
3. Reserve clusters for band selection RU in each reuse region
4. Sector permutation with the required block size
5. Logical indexing for all diversity RU and band selection RU

(Add the figure at page 11 in this slide).

- Section 11.x: DL reference signal

DL reference signal should be transmitted on one of the DL subframes once a frame (5msec).

Annex A: Normalized peak data rate

- TGm SRD requirement (*6.1 in SRD-80216m-07_002r4*)

Requirement type	Link direction	MIMO configuration	Normalized peak data rate (bps/Hz)
Baseline	Downlink	2x2	8.0
Target	Downlink	4x4	15.0

- Proposed symbol and pilot structure

Overhead	2x2 (Type A, B)	4x4	
		Type C	Type D
Guard band OH	5.5 %		
CP OH (1/8)	11.1 %		
Superframe header OH	3.09 %		
Pilot OH	11.1%	11.1%	22.2%
Idle time OH	1.26 %		
Total OH	28.55%	28.55%	37.48%
Normalized peak data rate (bps/Hz)	8.6	17.1	15.0

Assumption : 64QAM, code rate 1, and the other features are based on C802.16m-08/062r1

Annex B: Mobility support

- TGm SRD requirement (7.3 in SRD-80216m-07_002r4)

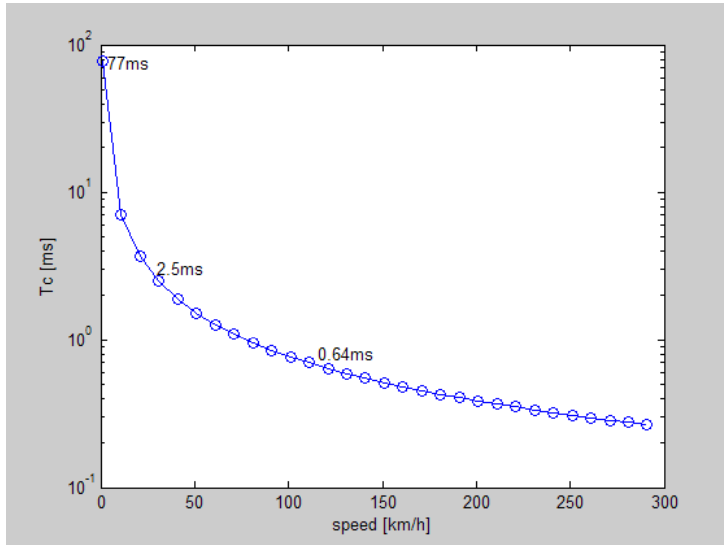

"- Optimized for Stationary, Pedestrian 0 - 10 km/h
 - Graceful degradation as a function of vehicular speed for Vehicular 10 - 120 km/h"

MS Speed and coherence time (Cor > 0.5)*

km/h	1	10	30	100	120	200	250	300
Tc (ms)	77	70	2.5	0.77	0.64	0.38	0.31	0.27
symbol	770	680	24.3	7.5	6.2	3.7	3	2.6

* Steele, R. Ed., Mobile Radio Communications, IEEE Pres, 1994

3~4 symbol-distance is desirable for Cor >> 0.5

Delay profile and coherence BW**

tap profile	coherence BW		# of tones	recommended distance (tone x symbol)
	Cor.> 0.9	Cor.>0.5		
Ped A	430kHz	4300kHz	39.3	(16 x 3)
Ped B	31.65kHz	316.5kHz	2.9	(3 x 3)
Veh A	53.48kHz	534.8kHz	4.9	(4 x 3)

** Lee, W.C.Y., Mobile Cellular Telecommunications Systems, McGraw Hill Publications, New York, 1989

Proposed symbol and pilot structure

	2Tx		4Tx
Pattern A	(3 x 3)	Pattern C	(6 x 3)
Pattern B		Pattern D	(3 x 1)

39 tone (PedA), 3~5 tone (PedB, VehA) - distance is desirable for Cor > 0.9