

Proposed UL Symbol Structure for 802.16m

IEEE 802.16 Presentation Submission Template (Rev. 9)

Document Number:

IEEE C802.16m-08/283

Date Submitted:

2008-05-05

Source:

Jeongho Park, Taeyoung Kim, Suryong Jeong,
Hyunkyuu Yu Jaeweon Cho, Heewon Kang, Hokyuu Choi, DS Park
Samsung Electronics Co., Ltd
416 Maetan-3, Suwon 443-770, Korea

Voice: +82-31-279-7528

E-mail: jeongho.jh.park@samsung.com

Venue:

IEEE 802.16m-08/005, "Call for Contributions on Project 802.16m System Description Document (SDD)",
on topic of 'Uplink Physical Resource Allocation Unit (Resource blocks and Symbol Structures)' and 'UL Pilot Structure'

Base Contribution:

None

Purpose:

To be discussed and adopted by TGM for the 802.16m SDD

Notice:

This document does not represent the agreed views of the IEEE 802.16 Working Group or any of its subgroups. It represents only the views of the participants listed in the "Source(s)" field above. It is offered as a basis for discussion. It is not binding on the contributor(s), who reserve(s) the right to add, amend or withdraw material contained herein.

Release:

The contributor grants a free, irrevocable license to the IEEE to incorporate material contained in this contribution, and any modifications thereof, in the creation of an IEEE Standards publication; to copyright in the IEEE's name any IEEE Standards publication even though it may include portions of this contribution; and at the IEEE's sole discretion to permit others to reproduce in whole or in part the resulting IEEE Standards publication. The contributor also acknowledges and accepts that this contribution may be made public by IEEE 802.16.

Patent Policy:

The contributor is familiar with the IEEE-SA Patent Policy and Procedures:

<<http://standards.ieee.org/guides/bylaws/sect6-7.html#6>> and <<http://standards.ieee.org/guides/opman/sect6.html#6.3>>.

Further information is located at <<http://standards.ieee.org/board/pat/pat-material.html>> and <<http://standards.ieee.org/board/pat>>.

Outline

- for 16m Green Field (= TDM based Legacy Support)
 - Summary
 - Uplink Symbol Structure
 - Rationales for each PRU
 - Subchannelization Procedure
- for FDM based Legacy Support
 - Summary
 - Considerations
 - Coexistence Concept
 - Resource Separation
- Proposed Text

**1. for 16m Green Field
(= TDM based Legacy Support)**

Summary

- 3 Types of PRU Structure
 - Type A: 1 PRU = 18×6 (subcarriers \times symbols)
 - Type B: 1 PRU = 6×6
 - Type C: 1 PRU = 3×6
- Pilot Structure
 - 1 Tx, CSM and 2Tx are considered
 - 11% per Antenna Pilot Density for 1Tx
 - 5.5 % per Antenna Pilot Density for 2Tx and CSM

UL Symbol Structure

- PRU Type A

- 1 PRU = 18 subcarriers × 6 symbols
- LRU structure
 - 1 LRU = 1 PRU
 - 96 data tones and 12 pilot tones
- Pilot density per antenna
 - 11% for 1Tx
 - 5.5% for 2Tx and CSM
- For localized resource allocation unit (LLRU)
- For diversity resource allocation unit (DRU) of large size packet



그림 바꾸기

UL Symbol Structure

- PRU Type B

- 1 PRU = 6 subcarriers × 6 symbols
- LRU structure
 - 1 LRU = 3 PRUs
 - 96 data tones and 12 pilot tones
- Pilot density per antenna
 - 11% for 1Tx
 - 5.5% for 2Tx and CSM
- For diversity resource allocation unit (DRU) of small size packet

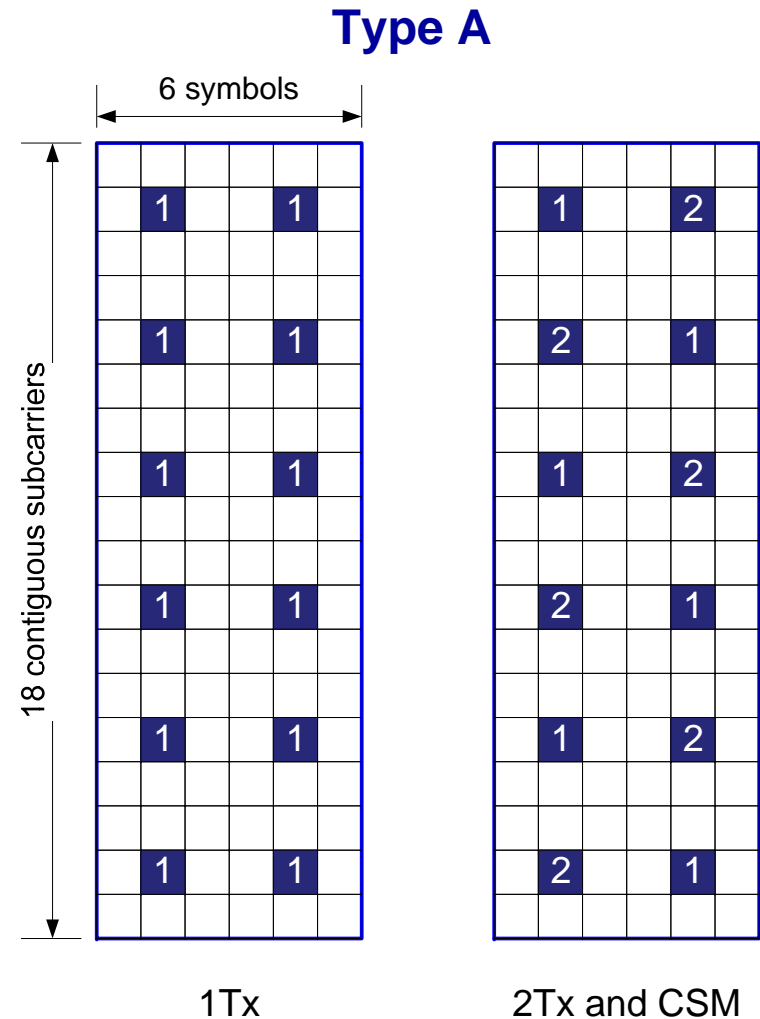
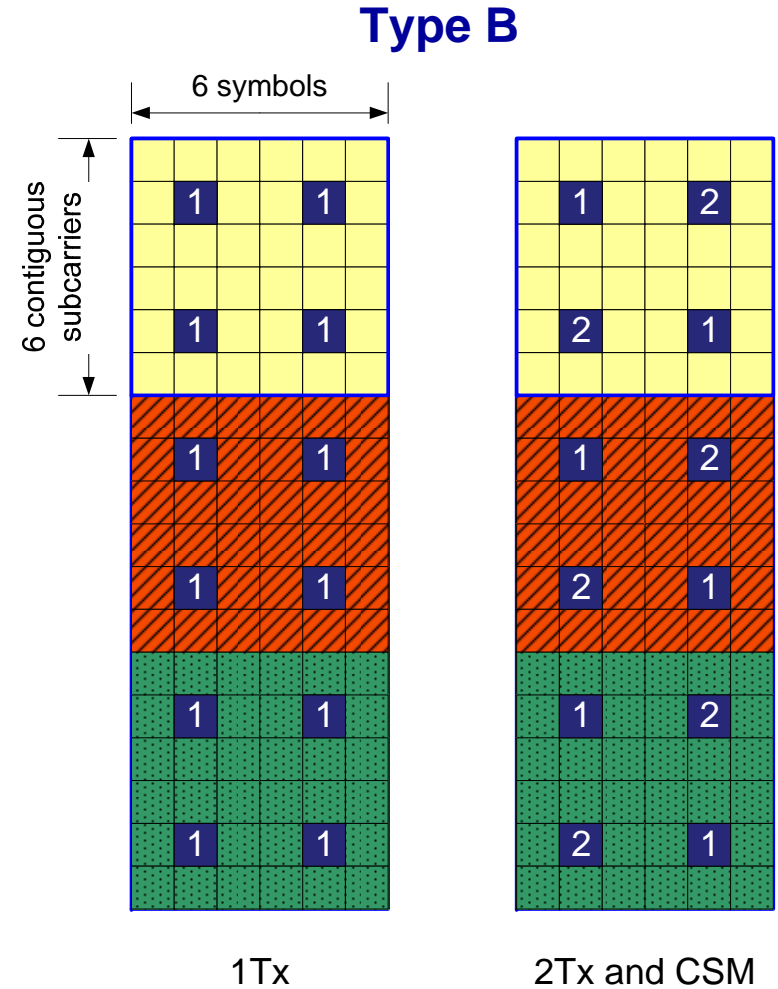

UL Symbol Structure

- PRU Type C
 - 1 PRU = 3 subcarriers × 6 symbols
 - LRU structure
 - 1 LRU = 3 PRUs
 - 48 data tones and 6 pilot tones
 - Pilot density per antenna
 - 11% for 1Tx
 - For control message and control channel

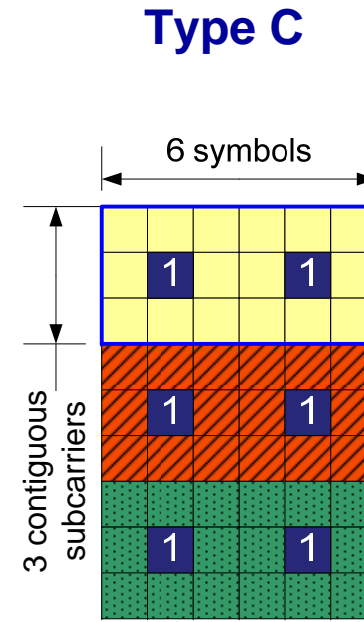

Rationale for PRU Type A

- Same Structure to Downlink PRU
 - This enable to leverage DL/UL reciprocity in TDD systems
- Better Channel Estimation Performance
 - Channel estimation would benefit from a large number of dedicated pilots in a big-size tile, especially in case of 2Tx or CSM
 - LLS comparison
 - CSM antenna pattern of Type A and Type B
 - Nep 480
 - QPSK, 1/2
 - VehA 30km/h
 - 4Rx Antennas

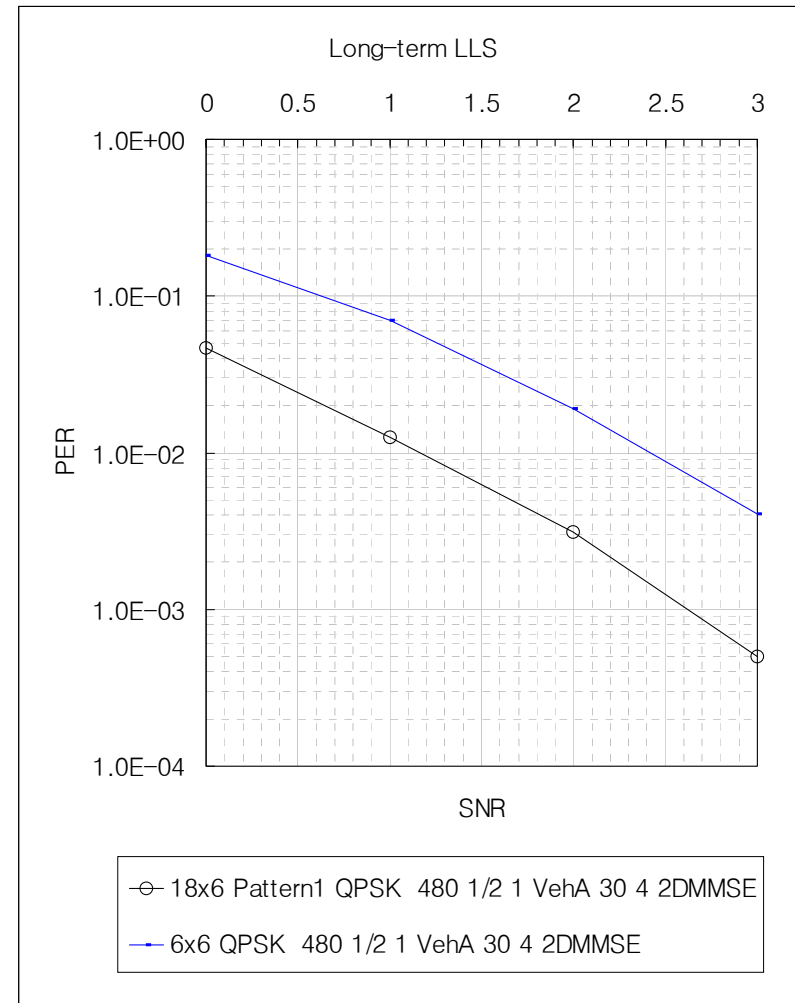

Rationale for PRU Type B (1/2)

- Better Frequency Diversity
 - Small packet will be maintained in 16m
 - Such like TCP ACK etc
- LLS verification
 - SNR gap due to freq. diversity btw PRU type A and PRU type B
 - Real channel estimation (2D MMSE)
 - Pilot pattern for 1 Tx
 - 2 Rx antennas and MCS QPSK 1/2

Small size packet ← → Large size packet

Case / Target PER		Nep Size			
		96	192	384	960
Ped B 3km/h	1%	2	1.6	0.5	0
	10%	0.4	0.4	0	0
Veh A 30km/h	1%	2.2	1.3	0.1	-0.6
	10%	0.6	0.1	-0.4	-0.4
Veh A 120km/h	1%	2.2	1.2	-0.2	-0.6
	10%	0.4	0	-0.6	-0.6

When Nep < 384, Type B is much better than A purely because of frequency diversity gain

Rationale for PRU Type B (2/2)

- SLS Verification for
 - Performance comparison with various PRU size
 - Total 4 different tile size (based on legacy PUSC 4x3 tile)
 - Tile 1. 1 subchannel = Six 4x3
 - Tile 2. 1 subchannel = Three 8x3
 - Tile 3. 1 subchannel = Two 12x3
 - Tile 4. 1 subchannel = One 24x3 tiles
 - Case I : Packet size is small
 - Only 2 subchannels are assigned to a user
 - Type 3 & type 4 has lack of freq. diversity
 - Case II : Packet size is large
 - 7 subchannels are assigned to a user
 - Full freq. diversity for all tile types

* Simulation conditions and assumptions are aligned with NGMN scenario in 802.16m EMD except

- number of users per sector (40/sector)
- number of assigned subchannels (Case I : 2, Case II : 7)
- channel model & mix : ITU PedB 100%

Case I

HARQ	OFF	OFF	OFF	OFF	ON	ON	ON	ON
Tile Type	4x3	8x3	12x3	24x3	4x3	8x3	12x3	24x3
Sector	2.1231	2.0232	1.9096	1.82	2.2089	2.1403	2.0984	2.0189
Tput(Mbps)	0.0%	4.7%	10.1%	14.3%	0.0%	3.1%	5.0%	8.6%
Cell edge	5.3	5.3	4.7	4.25	6.55	6.25	6.29	6.2
Tput(kbps)	0.0%	0.0%	11.3%	19.8%	0.0%	4.6%	4.0%	5.3%

Case II

HARQ	OFF	OFF	OFF	OFF	ON	ON	ON	ON
Tile Type	4x3	8x3	12x3	24x3	4x3	8x3	12x3	24x3
Sector	1.9663	1.9597	1.9592	1.9	2.1035	2.0844	2.0679	2.0438
Tput(Mbps)	0.0%	0.3%	0.4%	3.4%	0.0%	0.9%	1.7%	2.8%
Cell edge	4.42	4.41	4.3	4.2	6.15	6.15	5.592	5.58
Tput(kbps)	0.0%	0.2%	2.7%	5.0%	0.0%	0.0%	9.1%	9.3%

Only with large tile, system performance would be degraded especially when packet size is small

→ Type B can be good complement to Type A for small packet

Rationale for PRU Type C

- Current 16e has MAC header
 - Which size is only 48 bits (ex. BR request)
 - HARQ is not applied to
 - This might be retained in 16m
- Currently Used Feedback Header*
 - RoHC related
 - RoHC Feedback Header (under 10B)
 - RoHC-TCK ACK (min. 6B)
- New Control Message and Control Channel
 - Which could be designed as under 96 data tones
- These need guaranteed transmission has sufficient frequency diversity

→ *Type C can be good solution for control and header transmission*

Subchannelization Procedure

- Requirements
 - Sufficient frequency diversity for diversity resource allocation
 - Able to reserve preferred band for B. AMC allocation
 - FFR supportable
- High Level Concept

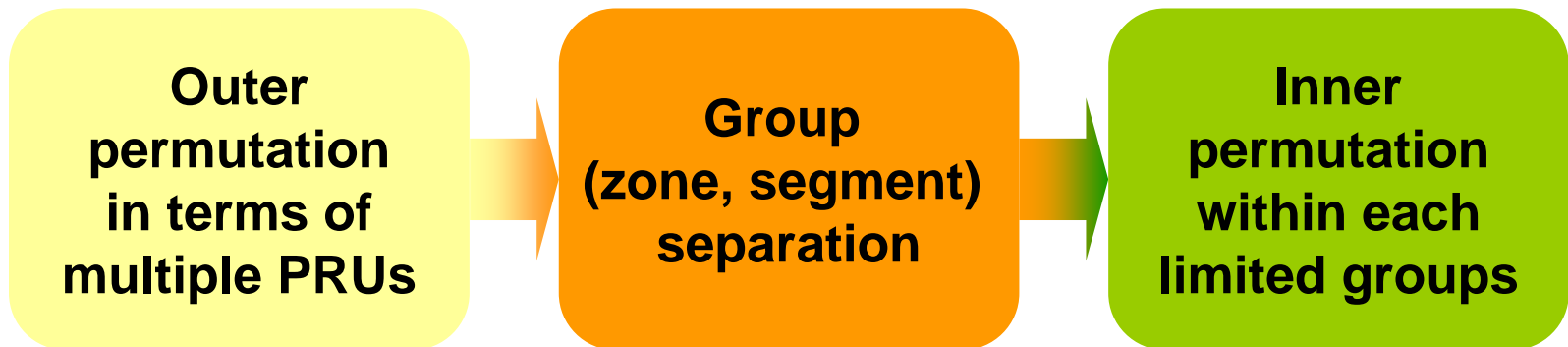

Subchannelization Procedure

- Details of Procedure

□ 18 contiguous tones (type A)

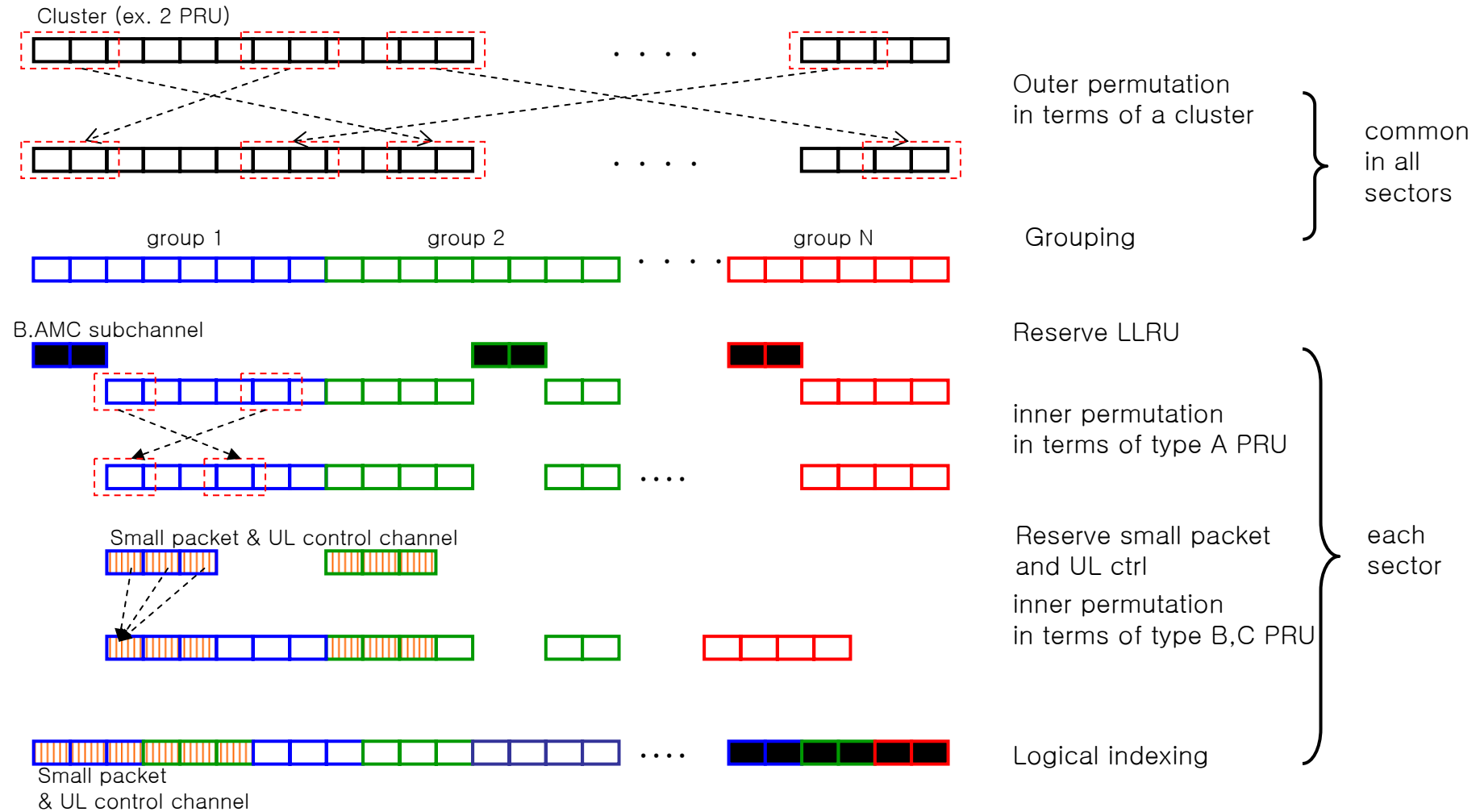

Diversity Resource Allocation

B.AMC Resource Allocation

2. for FDM based Legacy Support

Summary

- Objectives
 - To Find a Way 16e/16m Coexist based on FDM-manner
 - 16m Symbol Structure Design is Restricted due to Coexistence
- Requirements
 - 16m should not give rise to constraint on 16e operation
 - 16m should be comparable to stand-alone mode
- Proposed UL Diversity SubCH (DRU)
 - 'E-PUSC (Enhanced PUSC) ' represents proposed subchannel structure
 - A DRU is composed of five 4x6 tiles
 - 1 DRU : 120 tones (96 data, 24 pilots for 1Tx, 2Tx and CSM)
- Proposed UL B.AMC SubCH (LLRU)
 - A subchannel is 2x6 bins structures (18 subcarriers × 6 symbols)
 - 1 LLRU : 108 tones (96 data, 12 pilots for 1Tx, 2Tx and CSM)

Considerations

- UL Legacy Subchannel Types*
 - PUSC w/wo subchannel rotation
 - B. AMC of 2×3 bins
- Legacy and 16m coexistence in FDM manner
 - 16m diversity and B. AMC subchannel should be supported respectively
 - Legacy PUSC is mandatory because of Fast-feedback channels**

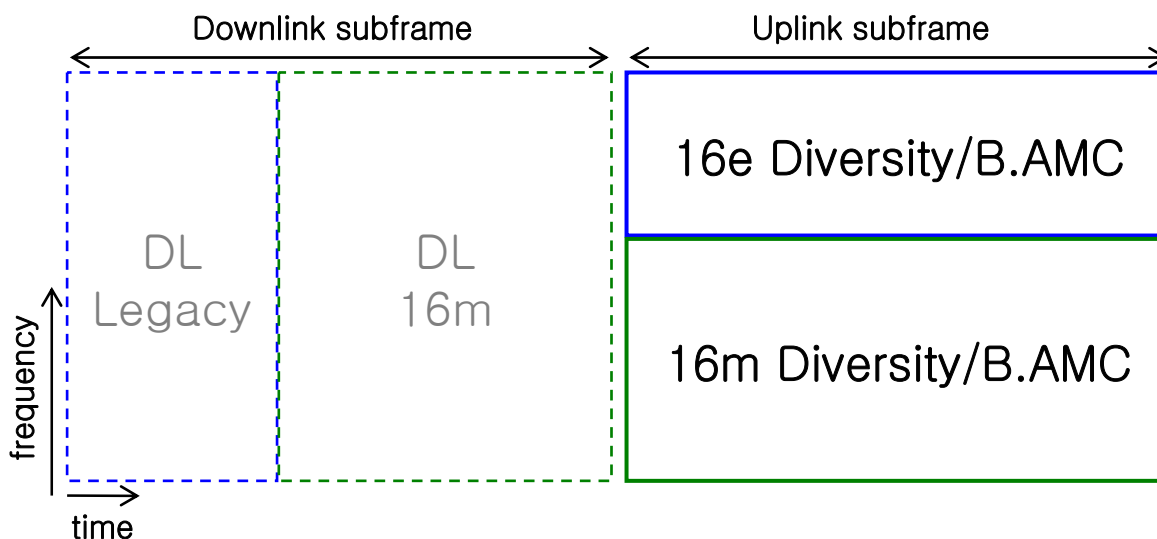

* WiMAX Forum™ Mobile System Profile Release 1.0 Approved Specification (4.1.2.2 of Revision 1.5.0: 2007-11-17)

16 ** Refer to 8.4.5.4.10 Fast-feedback channels and 8.4.5.4.25 HARQ ACK Region Allocation IE in SPEC Rev2/D3

Coexistence Concept (1/4)

- Possible Ways to Support 16m Diversity and B.AMC

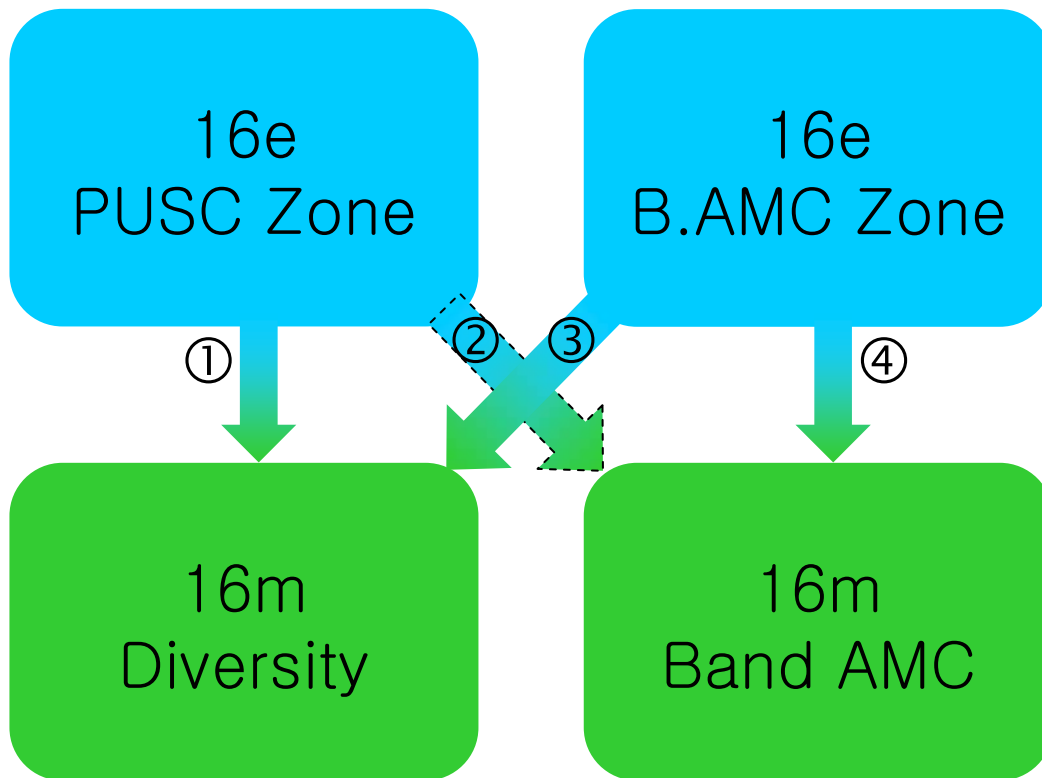

1	Adequate
2	Inadequate
3	Possible
4	Adequate

Coexistence Concept (2/4)

- Approach 1

- **Without** New 16m Diversity Structure
- Only 16e B.AMC zone supports 16m services

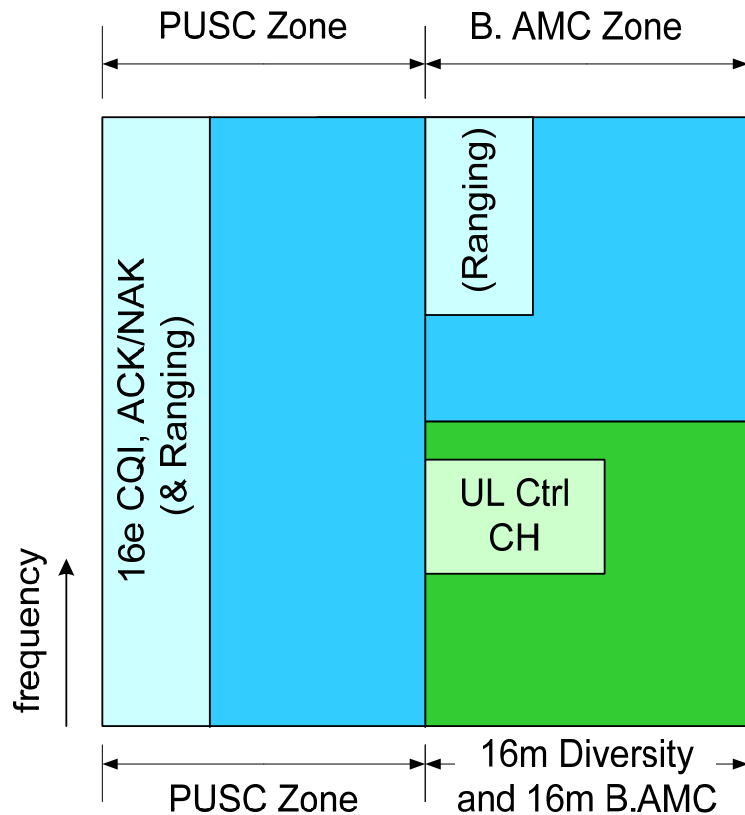

- Approach 2

- **With** New 16m Diversity Structure
- 16e PUSC and B.AMC zone support 16m services

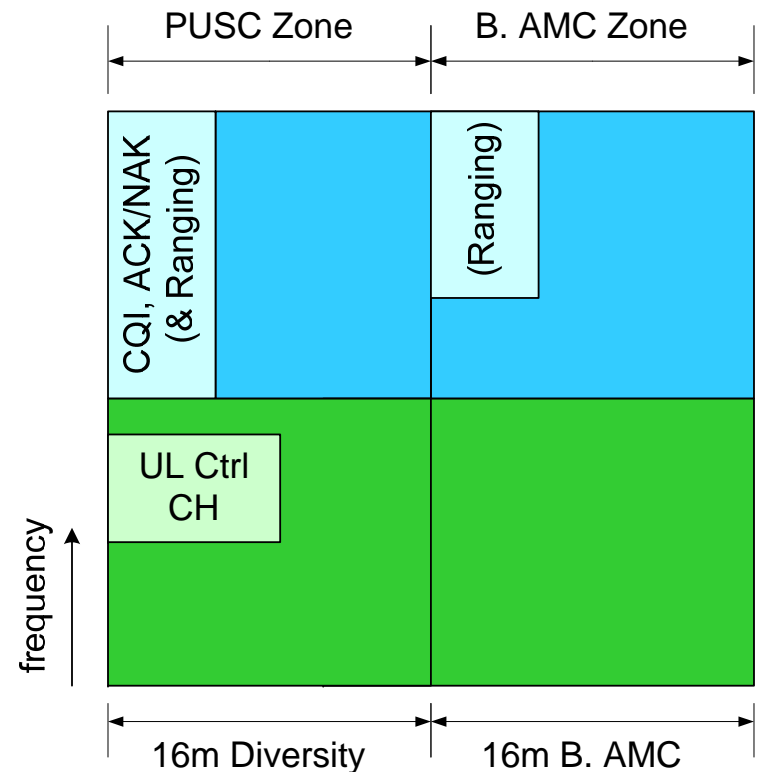

Coexistence Concept (3/4)

- Case Study

- When legacy system is operating with PUSC only

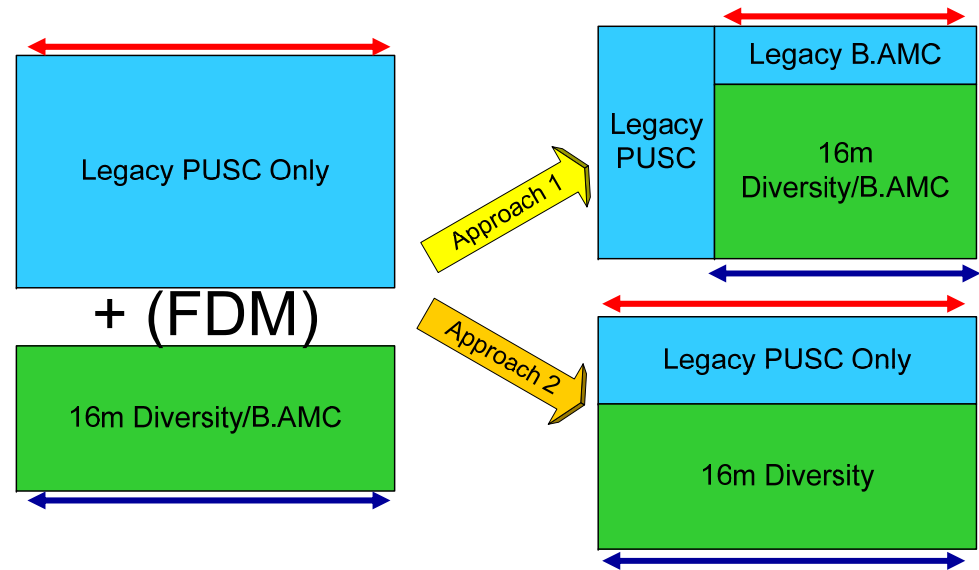

	Approach 1	Approach 2
Legacy view	<ul style="list-style-type: none"> - Need forced B.AMC zone - CSM not applicable in B.AMC zone - Concern about cell coverage 	<ul style="list-style-type: none"> - CSM supportable in PUSC zone
16m view	<ul style="list-style-type: none"> - Lower hardware complexity - Shorter UL coverage 	<ul style="list-style-type: none"> - Longer UL coverage - Higher hardware complexity

→ Taking everything into consideration, approach 2 is desirable.

Coexistence Concept (4/4)

- Proposed Scheme

- 16m subchannel types synchronize with 16e subchannel types
- 16m subchannel can be newly designed to enhance system performance

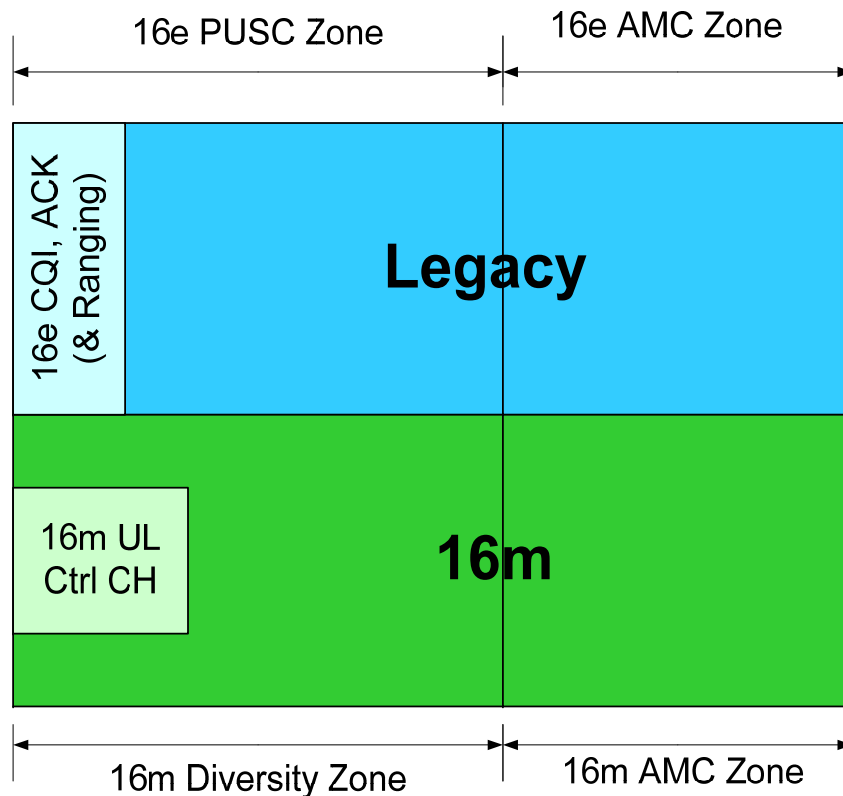

- Q) How to divide frequency domain resources into legacy and 16m ?

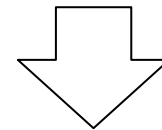

- A) By **UCD bitmap**

Resource Separation - for Diversity

- Proposed Approach

- Separation using UCD subchannels bitmap

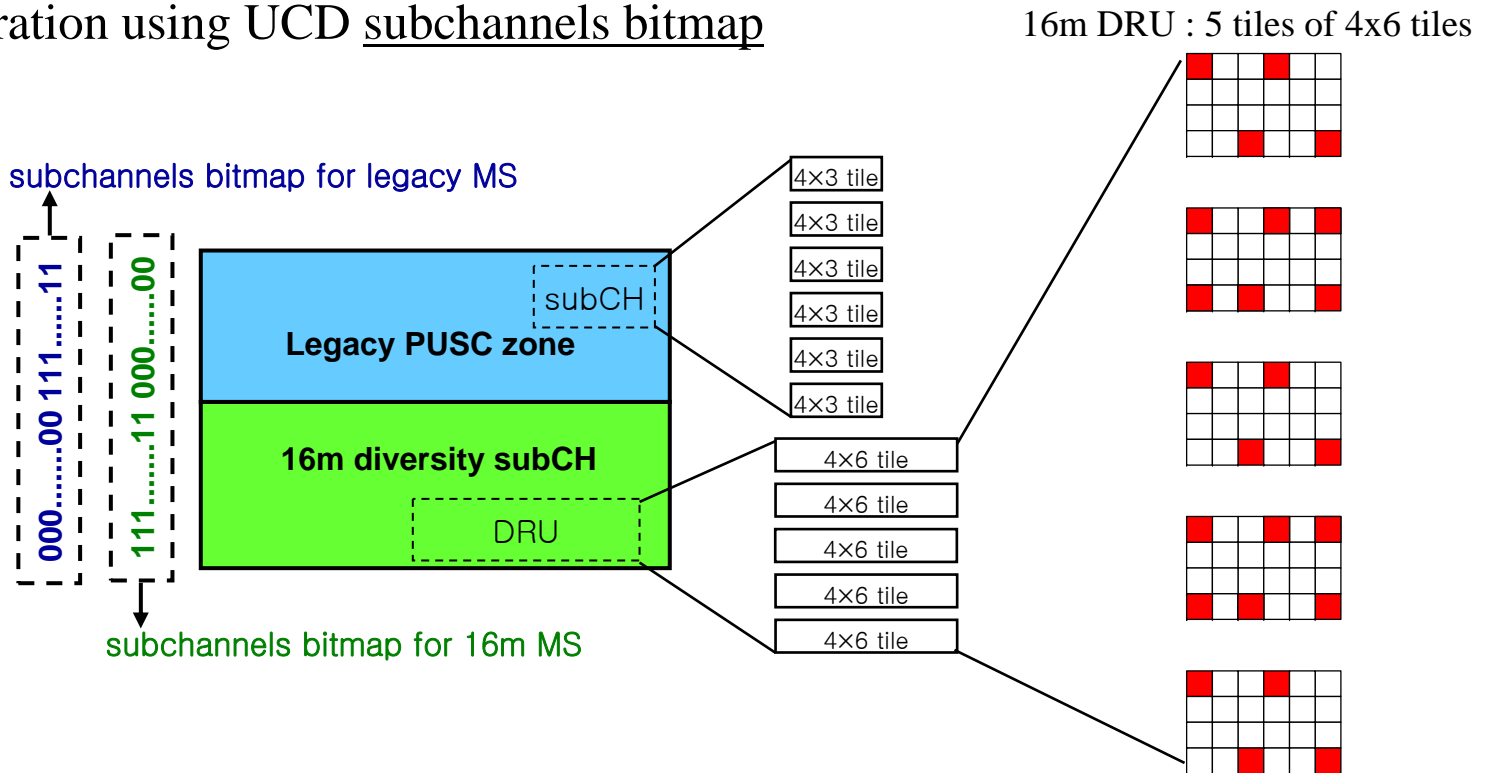

- Proposed approach can guarantee de-coupled subchannelization btw legacy and 16m
- The only signaling newly required for 16m is a kind of legacy UCD subchannels bitmap

Resource Separation - for Band AMC

- Proposed Approach

- Separation using UCD physical bands bitmap

16m LLRU :
18 subcarriers by 6 symbols

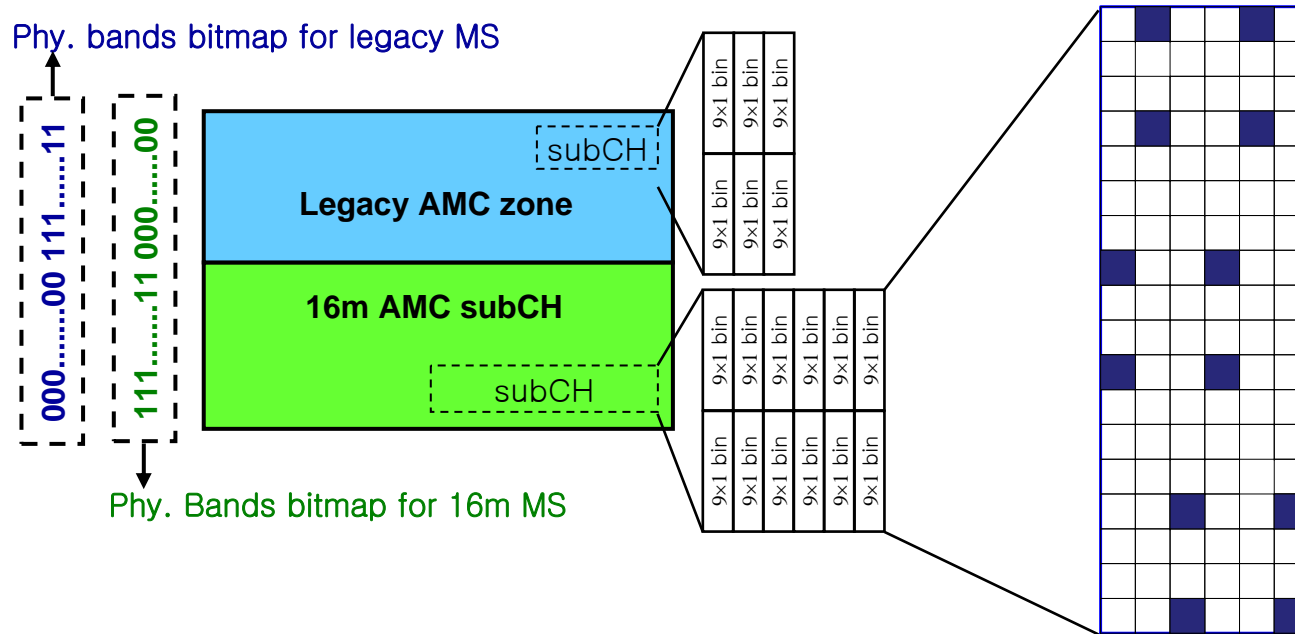

- The only signaling newly required for 16m is a kind of legacy UCD physical bands bitmap

E-PUSC – DRU

- Legacy 16e PUSC (4x3 tile)

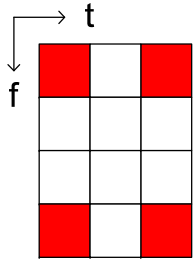

- Data tones / SubCH = 48
- Pilot OH = $4/12 = 33.3\%$

- E-PUSC (4x6 tile-based)

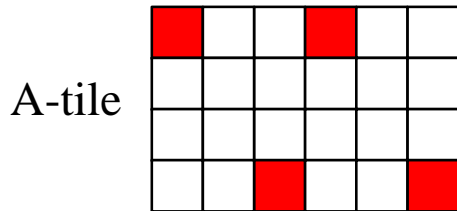

- Design Req : (1) Low Pilot OH (but more than 2 pilots in tile)
 (2) PUSC compatible (extension of 4x3 tile structure)
 (3) 96 data tones per subchannel

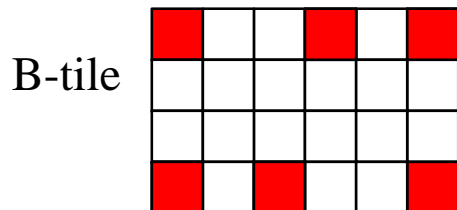

- 1 SubCH = $3 \times \text{A-tiles} + 2 \times \text{B-tile}$
- Data tones = 96
- Pilot density = $(4/24) \times 4/5 + (8/24) \times 1/5 = 20\%$ (1Tx, 2Tx and CSM)

DRU – Subchannelization Procedure

Maximize Commonality

- E-PUSC subchannelization can use legacy PUSC permutation as it is
- Only enumeration process is newly required

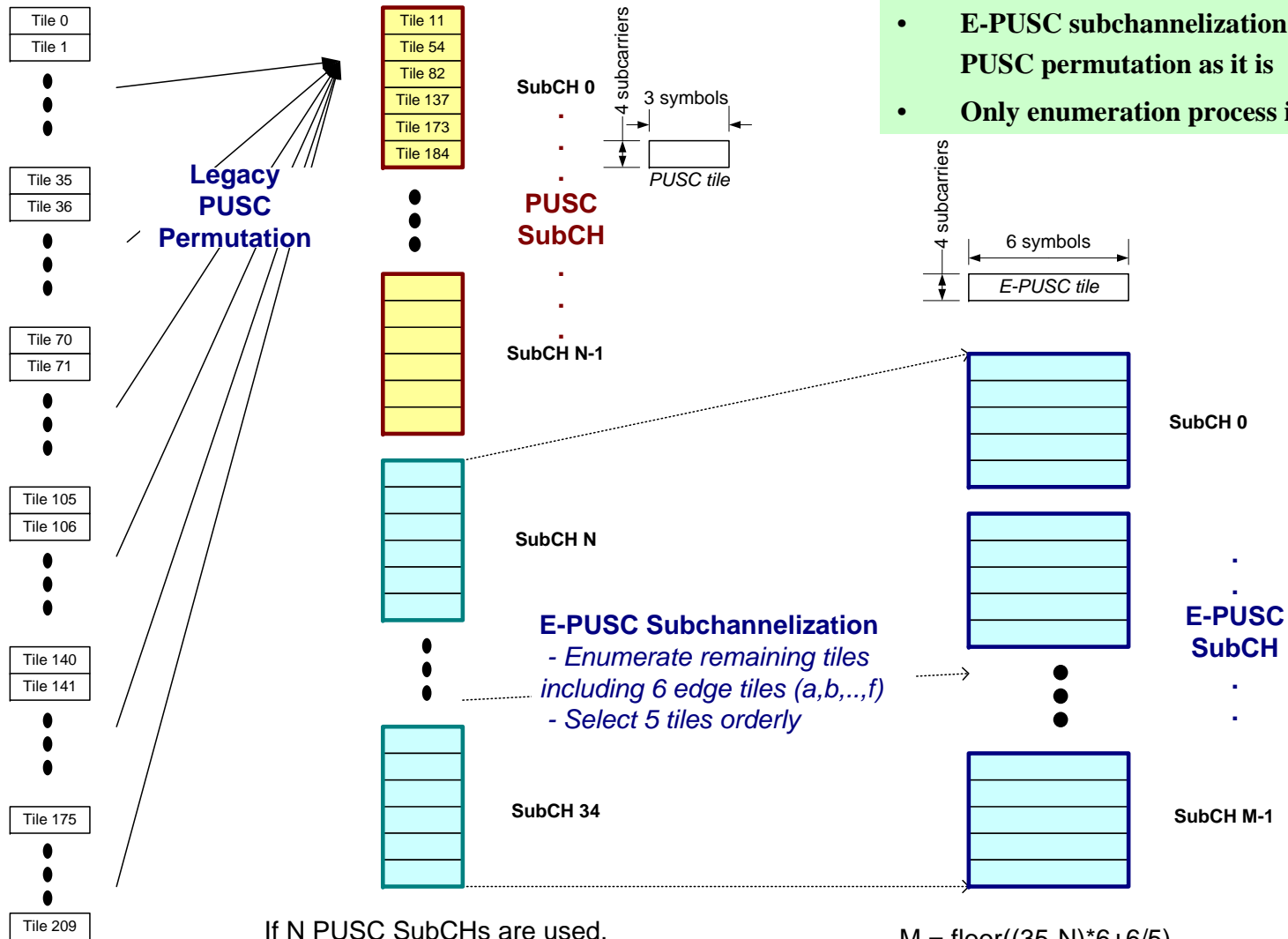

If N PUSC SubCHs are used,
 $(35-N)*6$ tiles will be left.

$$M = \text{floor}((35-N)*6+6/5)$$

LLRU – Subchannelization Procedure

- LLRU Subchannelization

- By using physical bands bitmap
- 1 physical band = 2 subchannels in B.AMC = 4 bins = 2 LLRU in 16m

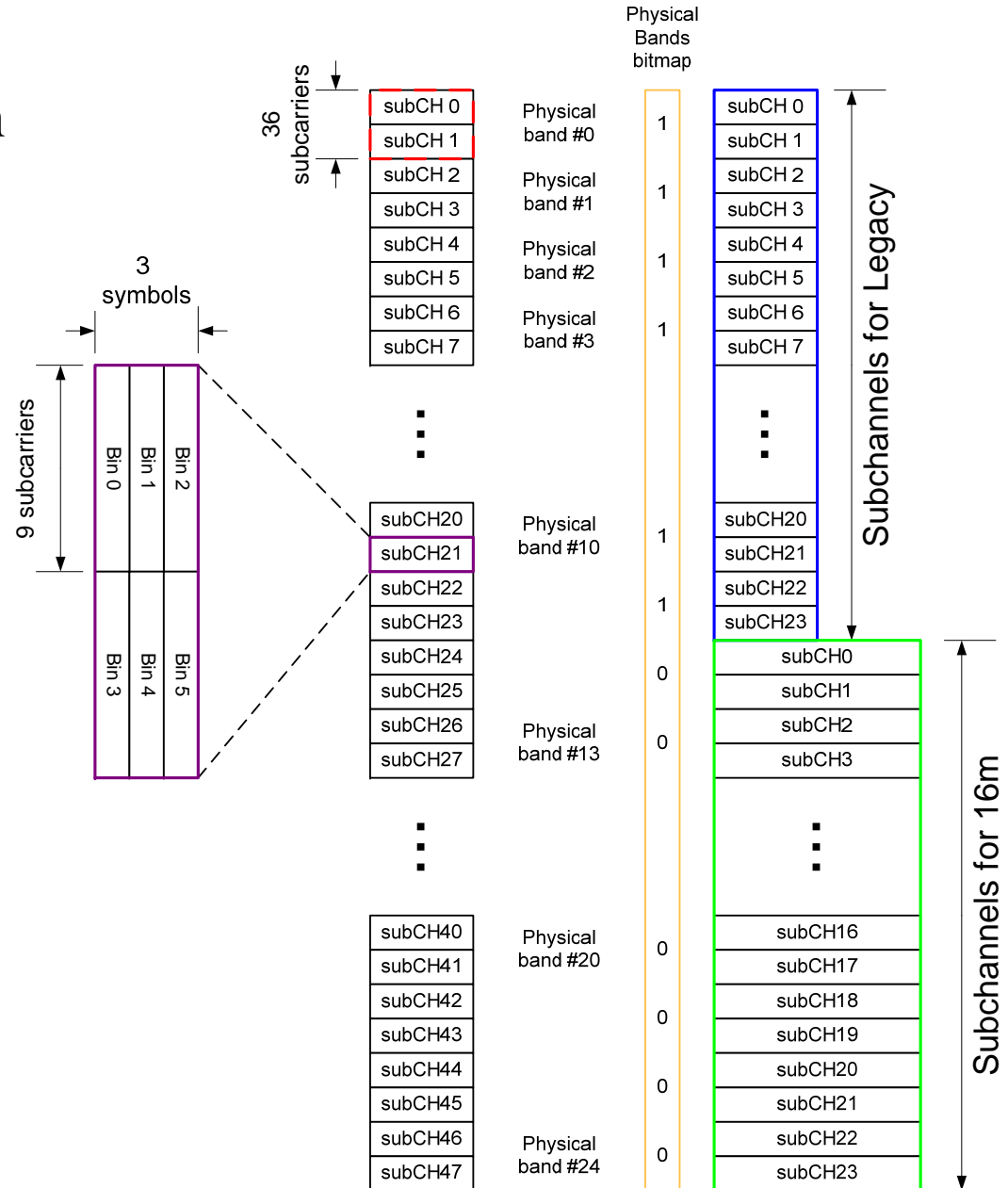

Proposed Text

Insert the following text into SDD Section 11 in IEEE 802.16m-08/003r1

Section 11.6 Uplink Physical Structure

Section 11.6.1 Physical and Logical Resource Unit

A physical resource unit (PRU) is the basic physical unit for resource allocation that comprises P_{sc} consecutive subcarriers by N_{sym} consecutive OFDMA symbols. For uplink PRU, three kinds of P_{sc} are used. The first one (type A) is 18, the second one (type B) is 6 and the third one (type C) is 3. N_{sym} equals to 6 for regular subframes and equals to 5 for irregular subframes.

A logical resource unit (LRU) is the basic logical unit for resource allocation that comprises L_{sc} subcarriers by N_{sym} consecutive OFDMA symbols. In the case of localized allocations, L_{sc} is equal either to 18 or 9. Therefore, one LRU should contain 108 tones for type A and type B PRU, or 54 tones for type C PRU including data and pilot tones for regular subframes.

Section 11.6.1.1 Distributed Resource Unit

The distributed resource unit (DRU) can be used to achieve frequency diversity gain. The minimum unit for forming the uplink DRU can be equal to any one of three PRU types.

Section 11.6.1.2 Localized Resource Unit

The localized resource unit (LLRU) can be used to achieve frequency-selective scheduling gain. The LLRU contains a group of subcarriers which are contiguous across the localized resource allocations. The size of the uplink LLRU equals to type A.

Proposed Text

Insert the following text into SDD Section 11 in IEEE 802.16m-08/003r1

11.6.2 Subchannelization and Resource Unit Mapping

11.6.2.1 Basic LRU and PRU Structure

Three types of LRU and PRU structure should be figure 11.6.2.1-1, figure 11.6.2.1-2 and figure 11.6.2.1-3

Type A

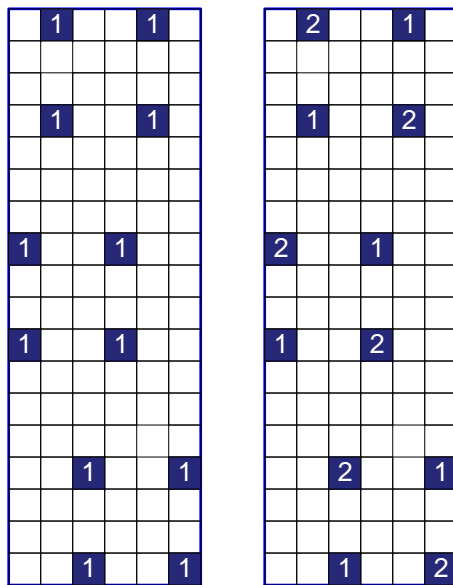

1Tx

2Tx and CSM

figure 11.6.2.1-1

Type B

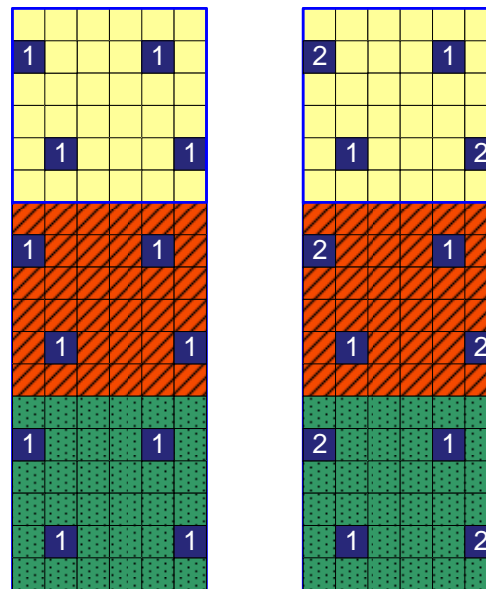

figure 11.6.2.1-2

Type C

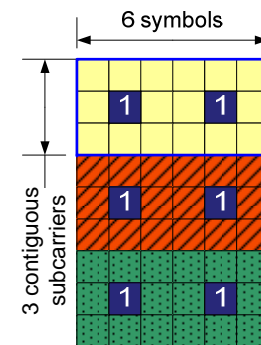

figure 11.6.2.1-3

Proposed Text

Insert the following text into SDD Section 11 in IEEE 802.16m-08/003r1

11.6.2.2 Resource Unit Mapping

Overall procedure of downlink subcarrier mapping to resource unit should be like below:

1. Outer permutation with cluster (A cluster can one or the multiples of type A PRU)
2. Divide total clusters into N groups which are separated exclusively in frequency domain
3. Reserve required clusters for LLRU in each group
4. Inner permutation in terms of type B and type C PRU
5. Logical indexing for all DRU and LLRU

Proposed Text

Insert the following text into SDD Section 11 in IEEE 802.16m-08/003r1

11.7 FDM based Legacy Support Mode

16m should be able to coexist with legacy system in FDM manner.

11.7.1 Physical and Logical Resource Unit

A physical resource unit (PRU) is the basic physical unit for resource allocation that comprises Psc consecutive subcarriers by Nsym consecutive OFDMA symbols. For uplink PRU in FDM based legacy support mode, two kinds of Psc are used. The first one is 18, the second one is 4.

A logical resource unit (LRU) is the basic logical unit for resource allocation that comprises Lsc subcarriers by Nsym consecutive OFDMA symbols. In the case of localized allocations, Lsc is equal either to 18 or 20. Therefore, one LRU should contain 108 tones for 18 Psc or 120 tones for 4 Psc.

Section 11.7.1.1 Distributed Resource Unit

The distributed resource unit (DRU) can be used to achieve frequency diversity gain. The minimum unit for forming the uplink DRU is equal to any one of two kinds of PRUs.

Section 11.7.1.2 Localized Resource Unit

The localized resource unit (LLRU) can be used to achieve frequency-selective scheduling gain. The LLRU contains a group of subcarriers which are contiguous across the localized resource allocations. The size of the uplink LLRU equals to the PRU which has 18 Psc.

Proposed Text

*Insert the following text into SDD Section 11 in IEEE
802.16m-08/003r1*

11.7.2 Subchannelization and Resource Unit Mapping

11.7.2.1 Basic LRU and PRU Structure

Three types of LRU and PRU structure should be figure
11.7.2.1-1 and figure 11.7.2.1-2

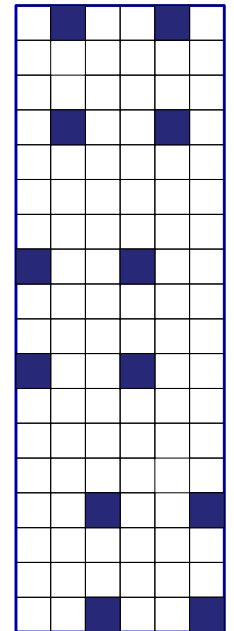
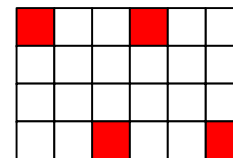
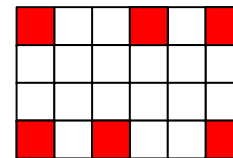
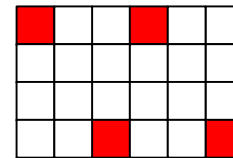
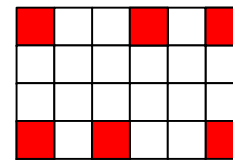
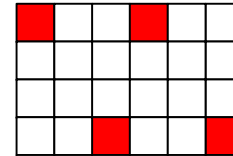

figure 11.7.2.1-1

figure 11.7.2.1-2