

IEEE 802.16m Uplink Control Channel Design Details and Updates

Document Number:

IEEE C802.16m-09/066

Date Submitted:

2009-01-07

Source:

Fan Wang, Weimin Xiao, Bishwarup Mondal, Weidong Yang, Amitava Ghosh

Mark Cudak, Fred Vook, Bill Hillery, Eugene Visotsky, Anup Talukdar

Motorola

E-mail: fanw@motorola.com

*<<http://standards.ieee.org/faqs/affiliationFAQ.html>>

Base Contribution:

IEEE C802.16m-09/066

Abstract:

Provide technical justification/details for UL PHY control structure contributions C802.16m-09/239, 240, 241.

Purpose:

Provide technical justification/details for UL PHY control structure contributions C802.16m-09/239, 240, 241

Notice:

This document does not represent the agreed views of the IEEE 802.16 Working Group or any of its subgroups. It represents only the views of the participants listed in the "Source(s)" field above. It is offered as a basis for discussion. It is not binding on the contributor(s), who reserve(s) the right to add, amend or withdraw material contained herein.

Release:

The contributor grants a free, irrevocable license to the IEEE to incorporate material contained in this contribution, and any modifications thereof, in the creation of an IEEE Standards publication; to copyright in the IEEE's name any IEEE Standards publication even though it may include portions of this contribution; and at the IEEE's sole discretion to permit others to reproduce in whole or in part the resulting IEEE Standards publication. The contributor also acknowledges and accepts that this contribution may be made public by IEEE 802.16.

Patent Policy:

The contributor is familiar with the IEEE-SA Patent Policy and Procedures:

<<http://standards.ieee.org/guides/bylaws/sect6-7.html#6>> and <<http://standards.ieee.org/guides/opman/sect6.html#6.3>>.

Further information is located at <<http://standards.ieee.org/board/pat/pat-material.html>> and <<http://standards.ieee.org/board/pat>>.

LTE CQICH Overhead

- ❑ CQICH allocation size (minimum unit)
 - 12 subcarriers by 14 symbols (1ms)
- ❑ CQICH load
 - 6 CQI channels by CDM
- ❑ CQICH overhead: 28 tones/CQICH channel

16m Fast Feedback (CQICH) Design

- ❑ 1 LRU (3 distributed tiles) shared by 4 CQICH
 - Pilot subcarriers are shared using CDM
 - Data subcarriers are shared using CDM
 - CDM has link budget advantage over TDM/FDM
 - **CQICH overhead: 27 tones/CQICH channel → Slightly lower overhead than LTE**
 - With only 3 CQICH (Samsung/Intel design), CQICH overhead 36 tones/CQICH → 28.6% higher than LTE
- ❑ To improve coverage, the tiles are allocated “time first”
 - Tile hopping in different subframes
 - Details in the next slides
- ❑ Support WB and NB CQICH feedback
- ❑ CQICH can also be transmitted with data using in-band control

Hierarchical CDM/TDM/FDM

- ❑ 2x2 block support 4 CQICH with CDM
 - 4 CQICH symbols CDM over 2x2 time/frequency contiguous tones → immune to time/frequency selective fading
- ❑ 2x6 block by concatenating 3 2x2 blocks with TDM
 - The middle 2x2 block can carry pilot symbols in order to support coherent detection
- ❑ 6x6 DRU tile by concatenating 3 2x6 blocks with FDM
- ❑ 3 DRU tiles form one control channel PRU
 - DRU tiles should be allocated “time first” in order to improve control channel coverage → take full advantage of MS tx power
 - DRU tiles should be allocated at different frequency in order to provide frequency diversity

16m CQICH Control Tile

- ❑ Coherent detection with pilot
- ❑ 1 control PRU shared by 4 CQICH channel
 - Spreading codes from MUB are used to further reduce the adjacent cell interference
- ❑ Each CQICH consists of 18 data symbols
 - Each symbol is QPSK modulated
 - Each symbol is further spread by a 4-bit orthogonal sequence
- ❑ Primary/basic CQICH
 - 72 18-symbol QPSK sequences
 - 64 sequences for 6-bit CQI information
 - 8 sequences for other purposes: BR indicator, etc.
- ❑ Secondary/enhanced CQICH
 - 12-bit enhanced CQICH
 - TB-CC (R=1/3) with QPSK modulation

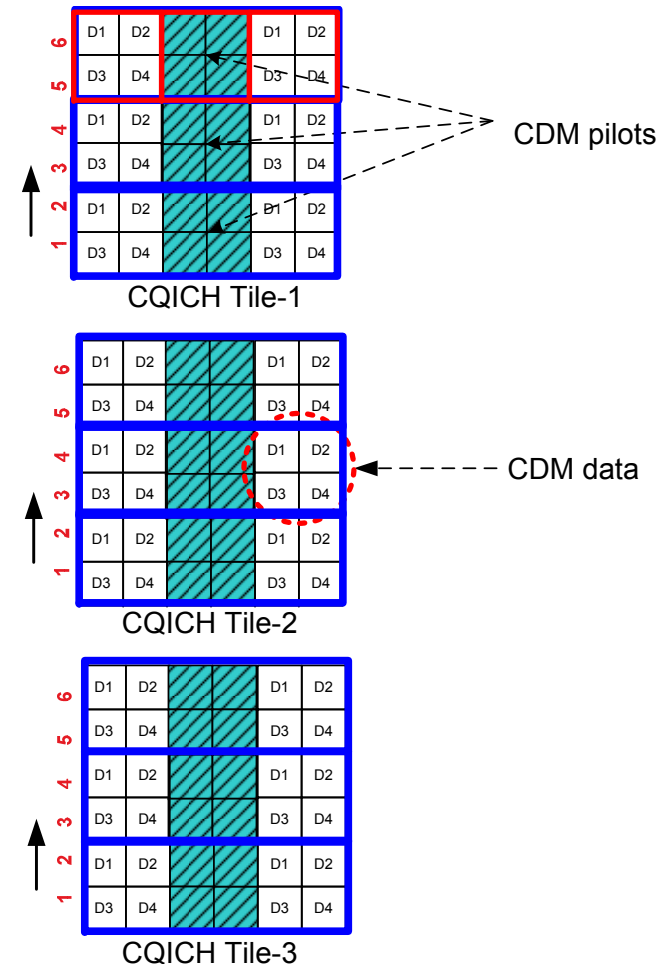

16m CQICH Tile Allocation

- ❑ 3 control tiles are allocated for each control PRU
- ❑ Tiles are allocated time-first
 - Link budget advantage in taking full advantage of MS tx power
 - Improved coverage

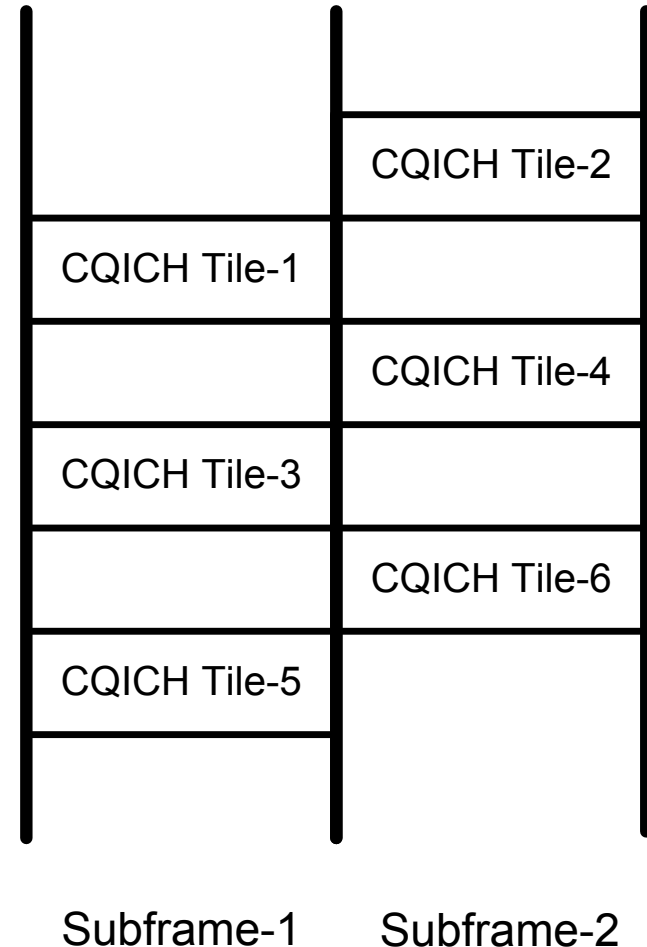

Adjacent Cell Interference Reduction using Spreading Codes from MUB

- ❑ Spreading codes from MUB provides least cross interference
- ❑ Five sets of MUB can be used for the length-4 CDM codes
 - For example: sector-1 uses Matrix-A, sector-2 uses Matrix-B, etc.

$$\mathbf{A} = \mathbf{U} \begin{bmatrix} 1 & 1 & 1 & 1 \\ 1 & 1 & -1 & -1 \\ 1 & -1 & -1 & 1 \\ 1 & -1 & 1 & -1 \end{bmatrix}, \mathbf{B} = \mathbf{U} \begin{bmatrix} 1 & 1 & 1 & 1 \\ -1 & -1 & 1 & 1 \\ -i & i & i & -i \\ -i & i & -i & i \end{bmatrix}, \mathbf{C} = \mathbf{U} \begin{bmatrix} 1 & 1 & 1 & 1 \\ -i & -i & i & i \\ -i & i & i & -i \\ -1 & 1 & -1 & 1 \end{bmatrix}, \mathbf{D} = \mathbf{U} \begin{bmatrix} 1 & 1 & 1 & 1 \\ i & i & -i & -i \\ 1 & -1 & -1 & 1 \\ -i & i & -i & i \end{bmatrix}, \mathbf{E} = \mathbf{U} \begin{bmatrix} 1 & 0 & 0 & 0 \\ 0 & 1 & 0 & 0 \\ 0 & 0 & 1 & 0 \\ 0 & 0 & 0 & 1 \end{bmatrix}$$

(72, 18) QPSK Sequences

	1	2	3	4	5	6	7	8	9	10	11	12	13	14	15	16	17	18
1	Q3	Q1	Q0	Q0	Q2	Q2	Q1	Q2	Q3	Q2	Q1	Q1	Q2	Q0	Q1	Q2	Q3	Q3
2	Q3	Q2	Q3	Q2	Q3	Q1	Q2	Q3	Q1	Q3	Q0	Q2	Q1	Q1	Q2	Q3	Q3	Q2
3	Q3	Q0	Q0	Q0	Q3	Q0	Q3	Q2	Q2	Q0	Q2	Q3	Q1	Q0	Q0	Q0	Q3	Q1
4	Q3	Q3	Q0	Q3	Q1	Q2	Q2	Q1	Q1	Q3	Q2	Q2	Q3	Q2	Q0	Q3	Q0	Q0
5	Q0	Q2	Q0	Q3	Q3	Q2	Q0	Q3	Q3	Q3	Q3	Q2	Q1	Q3	Q1	Q1	Q1	Q0
6	Q1	Q2	Q0	Q1	Q0	Q2	Q3	Q2	Q0	Q1	Q1	Q2	Q1	Q2	Q0	Q1	Q0	Q2
7	Q0	Q0	Q3	Q1	Q0	Q1	Q2	Q3	Q0	Q3	Q1	Q0	Q3	Q0	Q0	Q0	Q1	Q3
8	Q1	Q1	Q0	Q2	Q1	Q0	Q2	Q3	Q2	Q0	Q1	Q3	Q2	Q3	Q2	Q2	Q0	Q0
9	Q0	Q2	Q3	Q1	Q2	Q1	Q0	Q0	Q2	Q0	Q2	Q2	Q3	Q3	Q0	Q2	Q2	Q2
10	Q2	Q0	Q0	Q1	Q3	Q0	Q1	Q2	Q1	Q1	Q3	Q2	Q3	Q1	Q3	Q2	Q1	Q3
11	Q1	Q1	Q3	Q3	Q2	Q1	Q2	Q1	Q2	Q2	Q2	Q0	Q0	Q1	Q3	Q1	Q0	Q2
12	Q0	Q0	Q3	Q1	Q1	Q3	Q0	Q2	Q2	Q3	Q1	Q2	Q2	Q2	Q2	Q0	Q0	Q2
13	Q0	Q0	Q0	Q2	Q1	Q0	Q1	Q0	Q0	Q2	Q2	Q2	Q1	Q1	Q1	Q1	Q2	Q1
14	Q2	Q3	Q0	Q2	Q1	Q1	Q0	Q0	Q2	Q1	Q0	Q0	Q2	Q1	Q0	Q0	Q3	Q3
15	Q3	Q1	Q3	Q3	Q0	Q1	Q0	Q3	Q1	Q1	Q3	Q1	Q0	Q3	Q1	Q1	Q0	Q0
16	Q0	Q2	Q0	Q0	Q1	Q3	Q3	Q3	Q1	Q1	Q2	Q0	Q0	Q1	Q2	Q3	Q2	Q3
17	Q2	Q1	Q0	Q1	Q3	Q2	Q1	Q0	Q0	Q0	Q2	Q0	Q3	Q2	Q2	Q0	Q3	Q1
18	Q3	Q3	Q3	Q0	Q1	Q2	Q2	Q3	Q1	Q0	Q3	Q3	Q2	Q2	Q1	Q2	Q1	Q1
19	Q2	Q3	Q0	Q3	Q0	Q3	Q1	Q3	Q2	Q3	Q1	Q1	Q0	Q3	Q3	Q1	Q2	Q2
20	Q2	Q0	Q3	Q3	Q0	Q2	Q3	Q0	Q3	Q1	Q2	Q2	Q2	Q0	Q2	Q3	Q1	Q2
21	Q1	Q0	Q3	Q3	Q2	Q3	Q3	Q3	Q0	Q0	Q0	Q1	Q3	Q1	Q0	Q2	Q3	Q1
22	Q3	Q3	Q3	Q2	Q2	Q3	Q0	Q1	Q0	Q0	Q1	Q3	Q0	Q0	Q2	Q1	Q0	Q3
23	Q0	Q1	Q0	Q3	Q0	Q0	Q0	Q1	Q0	Q2	Q0	Q3	Q3	Q3	Q3	Q3	Q3	Q2
24	Q3	Q0	Q0	Q1	Q2	Q2	Q3	Q0	Q1	Q2	Q0	Q0	Q1	Q3	Q3	Q2	Q1	Q1
25	Q1	Q3	Q0	Q3	Q2	Q1	Q1	Q2	Q0	Q0	Q3	Q0	Q1	Q3	Q1	Q3	Q1	Q2
26	Q1	Q0	Q3	Q2	Q3	Q2	Q0	Q2	Q2	Q2	Q1	Q3	Q0	Q2	Q1	Q3	Q2	Q0
27	Q2	Q2	Q3	Q2	Q2	Q0	Q3	Q2	Q0	Q2	Q2	Q1	Q2	Q3	Q3	Q0	Q2	Q0
28	Q2	Q2	Q3	Q0	Q0	Q0	Q0	Q1	Q1	Q3	Q1	Q0	Q2	Q1	Q1	Q2	Q1	Q1
29	Q1	Q3	Q3	Q0	Q3	Q3	Q2	Q0	Q1	Q2	Q3	Q3	Q2	Q3	Q1	Q1	Q3	Q3
30	Q3	Q1	Q3	Q2	Q0	Q3	Q2	Q1	Q3	Q0	Q3	Q0	Q1	Q2	Q0	Q2	Q2	Q3
31	Q2	Q1	Q0	Q0	Q2	Q0	Q3	Q0	Q3	Q3	Q0	Q2	Q0	Q2	Q1	Q0	Q1	Q3
32	Q1	Q1	Q3	Q0	Q1	Q2	Q1	Q1	Q1	Q0	Q0	Q2	Q1	Q0	Q3	Q0	Q2	Q0
33	Q2	Q2	Q3	Q1	Q1	Q3	Q1	Q3	Q3	Q2	Q3	Q3	Q0	Q0	Q0	Q3	Q0	Q1
34	Q0	Q3	Q3	Q0	Q3	Q0	Q1	Q0	Q3	Q1	Q1	Q1	Q1	Q2	Q3	Q3	Q0	Q0
35	Q0	Q2	Q0	Q2	Q3	Q3	Q2	Q1	Q2	Q1	Q0	Q1	Q3	Q0	Q1	Q0	Q1	Q1
36	Q1	Q3	Q0	Q1	Q0	Q1	Q3	Q1	Q3	Q3	Q3	Q1	Q0	Q0	Q2	Q2	Q3	Q0

	1	2	3	4	5	6	7	8	9	10	11	12	13	14	15	16	17	18
37	Q1	Q3	Q2	Q2	Q0	Q0	Q3	Q0	Q1	Q0	Q3	Q3	Q0	Q2	Q3	Q0	Q1	Q1
38	Q1	Q0	Q1	Q0	Q1	Q3	Q0	Q1	Q3	Q1	Q2	Q0	Q3	Q3	Q0	Q1	Q1	Q0
39	Q1	Q2	Q2	Q2	Q1	Q2	Q1	Q0	Q0	Q2	Q0	Q1	Q3	Q2	Q2	Q2	Q1	Q3
40	Q1	Q1	Q2	Q1	Q3	Q0	Q0	Q3	Q3	Q1	Q0	Q0	Q1	Q0	Q2	Q1	Q2	Q2
41	Q2	Q0	Q2	Q1	Q1	Q0	Q2	Q1	Q1	Q1	Q1	Q1	Q1	Q0	Q3	Q1	Q3	Q2
42	Q3	Q0	Q2	Q3	Q2	Q0	Q1	Q0	Q2	Q3	Q3	Q0	Q3	Q0	Q2	Q3	Q2	Q0
43	Q2	Q2	Q1	Q3	Q2	Q3	Q0	Q1	Q2	Q1	Q3	Q2	Q1	Q2	Q2	Q2	Q3	Q1
44	Q3	Q3	Q2	Q0	Q3	Q2	Q0	Q1	Q0	Q2	Q3	Q1	Q0	Q1	Q0	Q0	Q2	Q2
45	Q2	Q0	Q1	Q3	Q0	Q3	Q2	Q2	Q0	Q2	Q0	Q0	Q1	Q1	Q2	Q0	Q0	Q0
46	Q0	Q2	Q2	Q3	Q1	Q2	Q3	Q0	Q3	Q3	Q1	Q0	Q1	Q3	Q1	Q0	Q3	Q1
47	Q3	Q3	Q1	Q1	Q0	Q3	Q0	Q3	Q0	Q0	Q2	Q2	Q3	Q1	Q3	Q1	Q3	Q0
48	Q2	Q2	Q1	Q3	Q3	Q1	Q2	Q0	Q0	Q1	Q1	Q3	Q0	Q0	Q0	Q2	Q2	Q0
49	Q2	Q2	Q2	Q0	Q3	Q2	Q3	Q2	Q2	Q0	Q0	Q0	Q3	Q3	Q3	Q3	Q0	Q3
50	Q0	Q1	Q2	Q0	Q3	Q3	Q2	Q2	Q0	Q3	Q2	Q2	Q0	Q3	Q2	Q2	Q1	Q1
51	Q1	Q3	Q1	Q1	Q2	Q3	Q2	Q1	Q3	Q3	Q1	Q3	Q2	Q1	Q3	Q3	Q2	Q2
52	Q2	Q0	Q2	Q2	Q3	Q1	Q1	Q1	Q3	Q3	Q0	Q2	Q2	Q3	Q0	Q1	Q0	Q1
53	Q0	Q3	Q2	Q3	Q1	Q0	Q3	Q2	Q2	Q2	Q0	Q2	Q1	Q0	Q0	Q2	Q1	Q3
54	Q1	Q1	Q1	Q2	Q3	Q3	Q0	Q0	Q1	Q3	Q2	Q1	Q1	Q0	Q0	Q3	Q0	Q3
55	Q0	Q1	Q2	Q1	Q2	Q1	Q3	Q1	Q0	Q1	Q3	Q3	Q2	Q1	Q1	Q3	Q0	Q0
56	Q0	Q2	Q1	Q1	Q2	Q0	Q1	Q2	Q1	Q3	Q0	Q0	Q0	Q2	Q0	Q1	Q3	Q0
57	Q3	Q2	Q1	Q1	Q0	Q1	Q1	Q1	Q2	Q2	Q2	Q3	Q1	Q3	Q2	Q0	Q1	Q3
58	Q1	Q1	Q1	Q0	Q0	Q1	Q2	Q3	Q2	Q2	Q3	Q1	Q2	Q2	Q0	Q3	Q2	Q1
59	Q2	Q3	Q2	Q1	Q2	Q2	Q2	Q3	Q2	Q0	Q2	Q1	Q1	Q1	Q1	Q1	Q1	Q0
60	Q1	Q2	Q2	Q3	Q0	Q0	Q1	Q2	Q3	Q0	Q2	Q2	Q3	Q1	Q1	Q0	Q3	Q3
61	Q3	Q1	Q2	Q1	Q0	Q3	Q3	Q0	Q2	Q2	Q1	Q2	Q3	Q1	Q3	Q1	Q3	Q0
62	Q3	Q2	Q1	Q0	Q1	Q0	Q2	Q0	Q0	Q0	Q3	Q1	Q2	Q0	Q3	Q1	Q0	Q2
63	Q0	Q0	Q1	Q0	Q0	Q2	Q1	Q0	Q2	Q0	Q0	Q3	Q0	Q1	Q1	Q2	Q0	Q2
64	Q0	Q0	Q1	Q2	Q2	Q2	Q2	Q3	Q3	Q1	Q3	Q2	Q0	Q3	Q3	Q0	Q3	Q3
65	Q3	Q1	Q1	Q2	Q1	Q1	Q0	Q2	Q3	Q0	Q1	Q1	Q0	Q1	Q3	Q3	Q1	Q1
66	Q1	Q3	Q1	Q0	Q2	Q1	Q0	Q3	Q1	Q2	Q1	Q2	Q3	Q0	Q2	Q0	Q0	Q1
67	Q0	Q3	Q2	Q2	Q0	Q2	Q1	Q2	Q1	Q1	Q2	Q0	Q2	Q0	Q3	Q2	Q3	Q1
68	Q3	Q3	Q1	Q2	Q3	Q0	Q3	Q3	Q3	Q2	Q0	Q3	Q2	Q1	Q2	Q1	Q2	Q0
69	Q0	Q0	Q1	Q3	Q3	Q1	Q3	Q1	Q1	Q0	Q1	Q1	Q2	Q2	Q2	Q1	Q2	Q3
70	Q2	Q1	Q1	Q2	Q1	Q2	Q3	Q2	Q1	Q3	Q3	Q3	Q3	Q0	Q1	Q1	Q2	Q2
71	Q2	Q0	Q2	Q0	Q1	Q1	Q0	Q3	Q0	Q3	Q2	Q3	Q1	Q2	Q3	Q2	Q3	Q3
72	Q3	Q1	Q2	Q3	Q2	Q3	Q1	Q3	Q1	Q1	Q3	Q2	Q2	Q0	Q0	Q1	Q2	Q2

$$Q0 = \exp\left(j \frac{\pi}{4}\right);$$

$$Q1 = \exp\left(j \frac{3\pi}{4}\right);$$

$$Q2 = \exp\left(-j \frac{3\pi}{4}\right);$$

$$Q3 = \exp\left(-j \frac{\pi}{4}\right);$$

Cross Code Interference

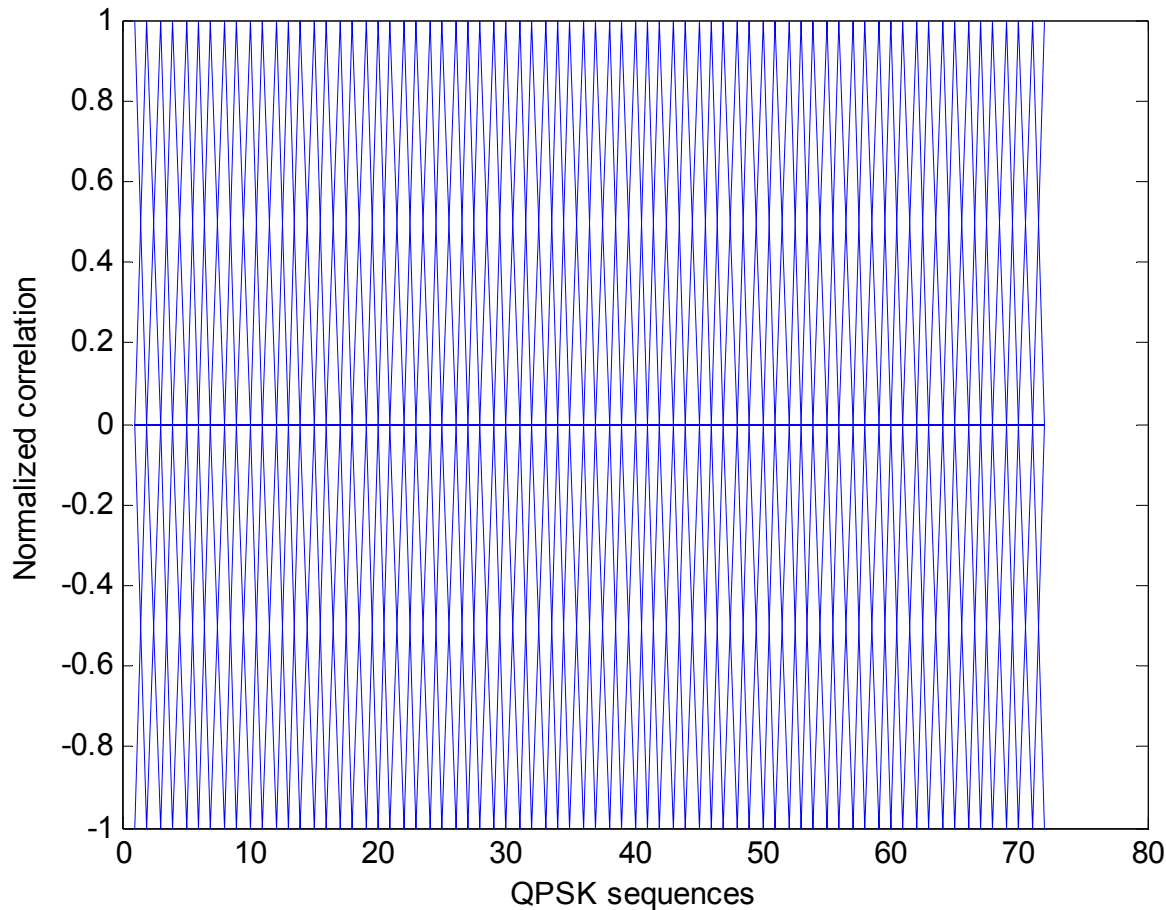

- ❑ Cross correlation between any pair of 72 sequences ≤ 0
- ❑ Slightly better link performance than the (64, 18) sequences in C80216m-UL_PHY_Ctrl-08_058

An Alternative Set of Sequences

- ❑ An alternative set of complex sequences that have similar property can be made by DFT matrix $[F; -F; jF; -jF]$ where F is the 18×18 DFT matrix
- ❑ Link performance is slightly worse than the set of $(72, 18)$ QPSK sequences

16m CQI Information Content (Primary Fast Feedback)

- ❑ Support 72 values (sequences)
- ❑ 64 values for CINR feedback
 - Physical CINR feedback
 - 48 values for mean CINR (-10 dB to 38 dB with 1dB step)
 - 8 values for standard deviation of CINR over frequency
 - Provide a better characterization of frequency selective fading channel
 - 8 values standard deviation of CINR over time
 - Provide a better characterization of time selective fading channel
 - Effective CINR feedback
 - Up to 64 values of MCS
 - Narrow band CINR feedback (B-AMC type)
 - Best-6 subband differential feedback
- ❑ 4 values for rank indication (RI=1, 2, 4, 8)
- ❑ 1 value for bandwidth request indicator
- ❑ 3 values reserved

16m CQI Information Content (Standard Deviations of Physical CINR)

- ❑ Standard deviation of CINR over time
 - Provide a characterization of time varying fading channel
 - 16e spec provides two options:
 - dB based STD is preferred
 - Linear value based STD needs to be normalized

- ❑ Standard deviation of CINR over frequency
 - Provide a characterization of frequency selective fading channel

16m CQI Information Content (Secondary Fast Feedback)

- ❑ Closed loop MIMO CQI feedback
 - 6-bit CQI, 4-bit PMI (rotate for best-6 bands), 2-bit rank indication
 - Additional PMI (such as narrow band PMI) can be feedback with in-band control
 - Other contents are FFS

CQICH Timing

- ❑ MS (or by the request of Bs) may choose to feedback mean of CINR, standard deviations of CINR, rank indication, narrow band CINR, etc
- ❑ CQI is feedback on CQICH periodically
 - Standard deviation can be inserted with lower frequency
- ❑ RI (rank indicator) can be inserted with low frequency
- ❑ WB CQI and NB CQI can be interlaced, with NB CQI report having higher frequency

CQICH Timing

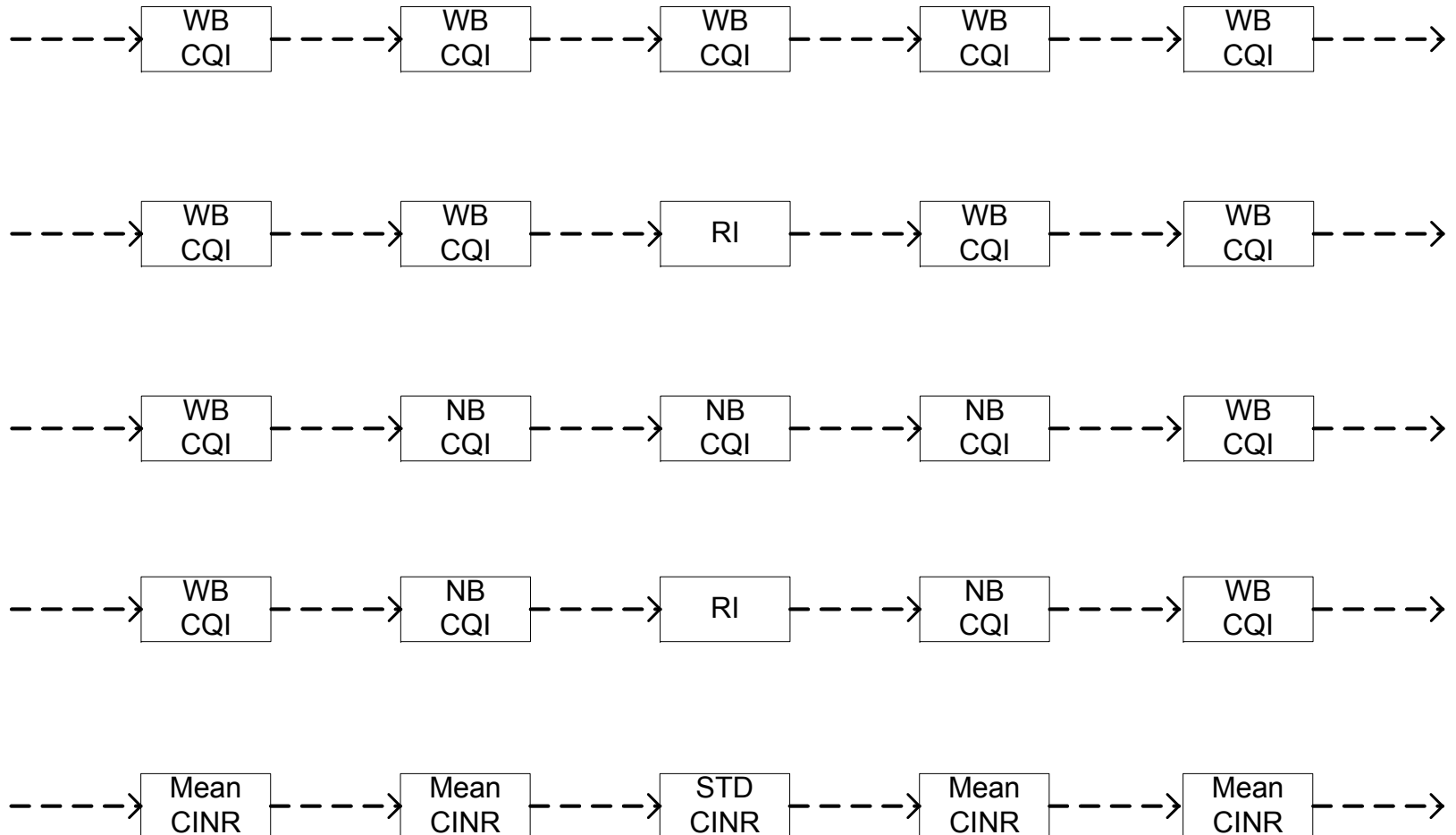

Link Simulation Parameters

Parameter	Value
NFFT	1024
Carrier frequency	2.6 GHz
# Tx antennas	1
# Rx antennas	2
Antenna spacing	4λ
CCH design	Motorola, Samsung-982r2 (Intel 937r2)
Channel model	PB3, VA120, VA350
Pilots	no pilot boost, orthogonal pilots for 4 UL users
Receiver	MRC for CQICH, correlator for ACK
UL channel estimator	average
Packet size	6 info-bits for CQICH

CQICH Performance 1

□ VA120 (per-tone SNR)

□ PB3 (per-tone SNR)

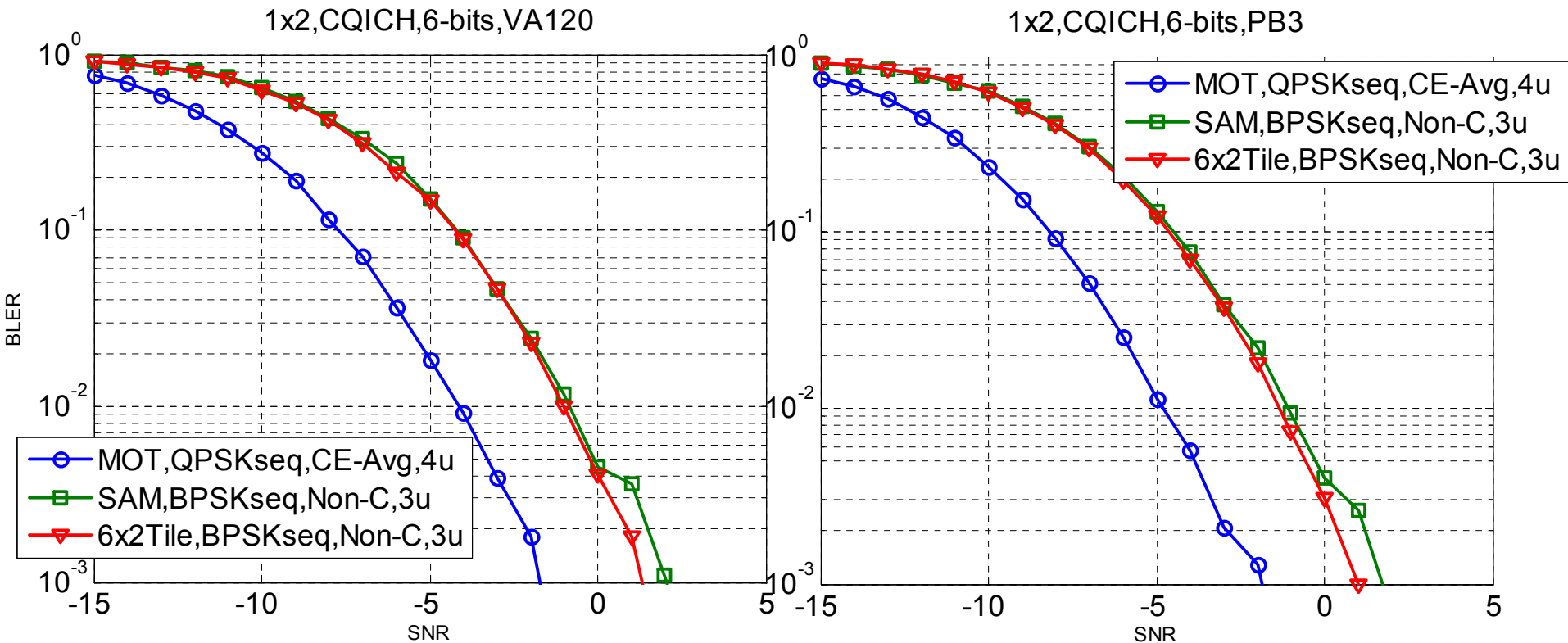

□ Motorola proposal CDM over 3x subcarriers

- Relative performance shifted by $10 \cdot \log_{10}(3) = 4.78$ dB between per_tone_SNR and per_infobit_SNR

CQICH Performance 2

VA350

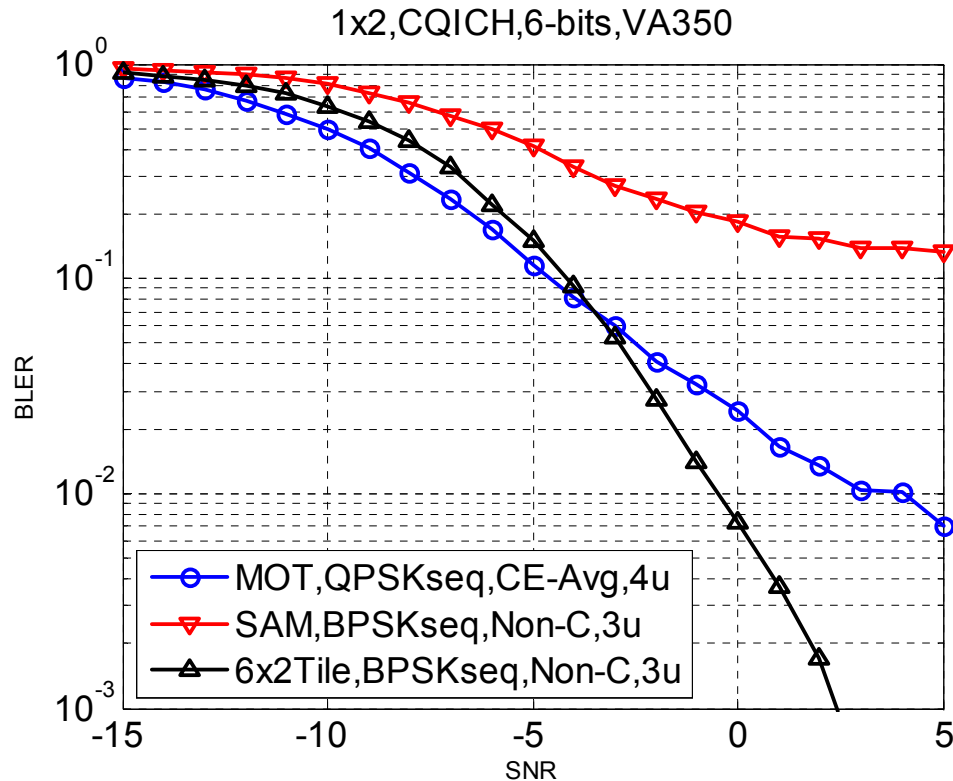

- ❑ MOT design avoids interference floor at high speed
- ❑ 2x6 design results can be further improved with more advanced receiver

CQICH Performance 3

□ VB3

□ HT3

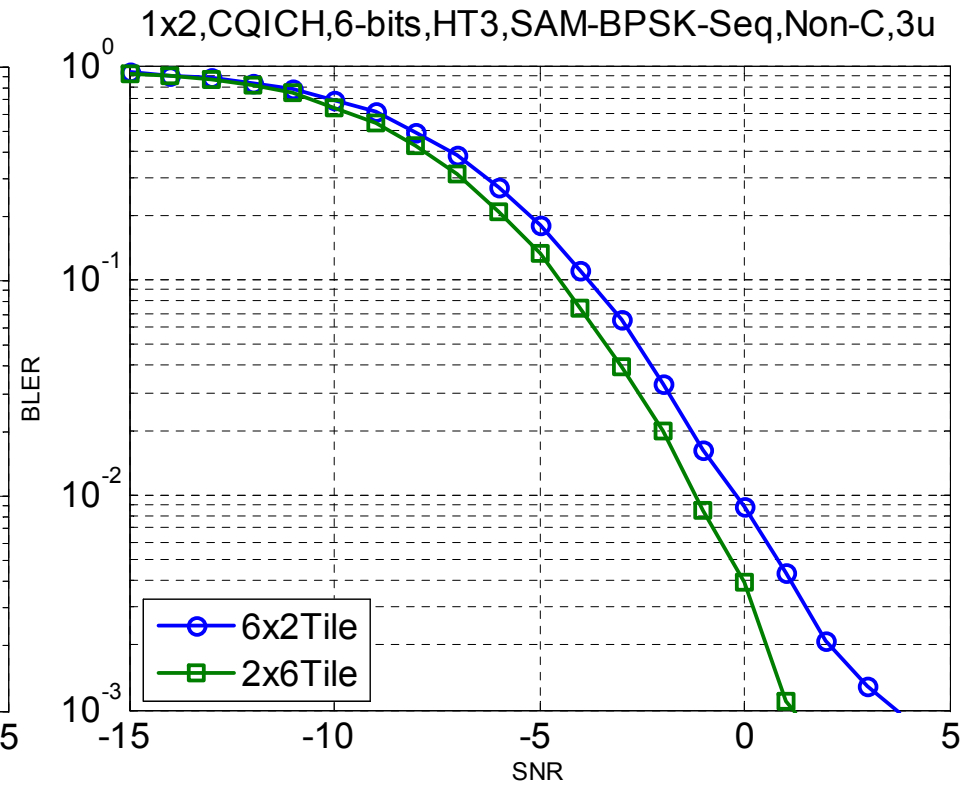
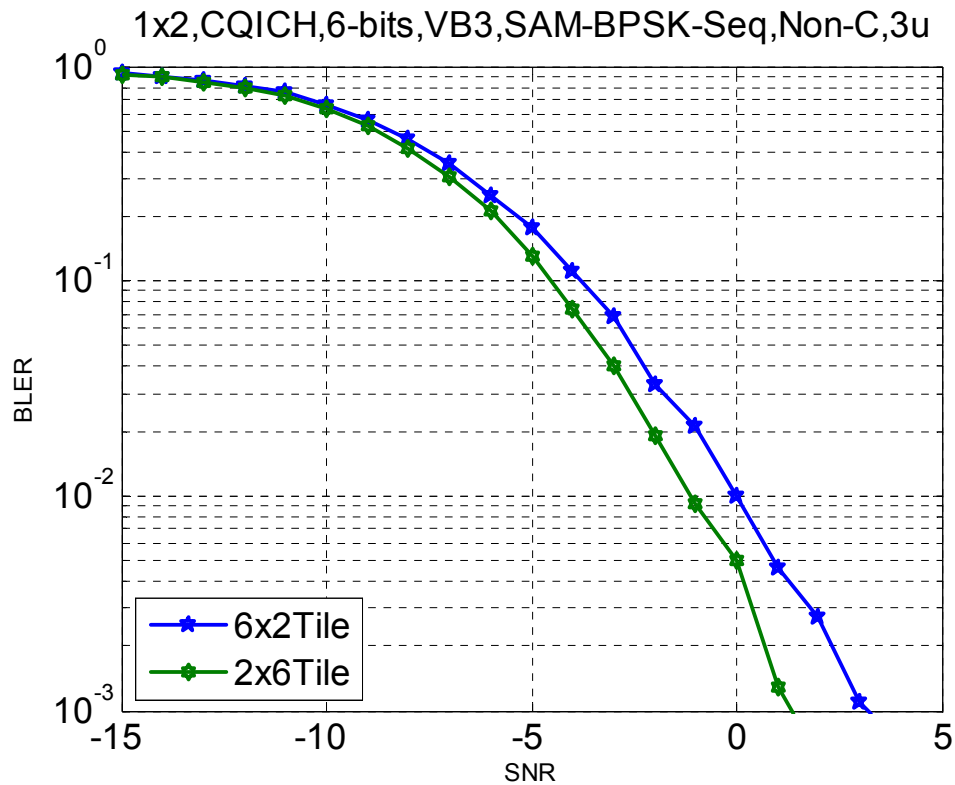

Performance Comparison

- ❑ Non-coherent (BPSK) vs Coherent (QPSK) w/ CDM
 - Non-coherent (BPSK) is about 1dB better in SNR per info bit
 - Coherent (QPSK) w/ CDM provides 33% more user capacity
 - ~1.25 dB gain over non-coherent design
 - Further, Coherent (QPSK) w/ CDM supports 72 sequences vs 64 sequences in non-coherent (BPSK)

2x6 vs 6x2

- ❑ All 2x6 design can be adapted for 6x2 tile structure
- ❑ 2x6
 - Advantages
 - Same tile structure for both green field & legacy modes
 - Disadvantage
 - Performance degradation in extreme high speed (350 kmph)
- ❑ 6x2
 - Advantages
 - Better performance in extreme high speed (350 kmph)
 - Disadvantages
 - Require a new tile structure for legacy mode → Complicate 16m design
 - Possibly 4x3 or 4x6
 - Performance degradation in high delay spread channels

High Speed vs High Delay Spread

- ❑ High speed impact
 - 350kmph, 2.6 GHz $\rightarrow f_d=843$ Hz \rightarrow coherence time $\sim 1/f_d=1.3$ ms
 - 6 OFDM symbols $\rightarrow 0.62$ ms
 - High speed channel degrades 2x6 performance
- ❑ High delay spread impact
 - Some fading channels (e.g. Veh-B, COST 259 HT) have delay spread up to 10 to 20 μ s
 - Channel models are not in 16m EVM, but well-known in real world
 - Ped-B, Veh-A have only delay spread up to 3~4 μ s
 - 16m CP 11.4 μ s
 - DS 10 μ s \rightarrow coherence frequency $\sim 1/DS=100$ kHz
 - 6 subcarriers $\rightarrow 65.6$ kHz
 - High delay spread channel may degrade 6x2 performance

HARQ Feedback Channel

LTE ACK/NACK Overhead

- ❑ ACK/NACK allocation size (minimum unit)
 - 12 subcarriers by 14 symbols (1ms)
- ❑ ACK/NACK load
 - 18 ACK/NACK channels by CDM
- ❑ **ACK/NACK overhead: 9.3 tones/ACK/NACK channel**

16m ACK/NACK Design

- ❑ 1 PRU (3 distributed tiles) shared by 18 ACK/NACK
 - Data subcarriers are shared using CDM
 - CDM has link budget advantage over TDM/FDM
 - ACK/NACK overhead: 9 tones/ACK/NACK channel
- ❑ To improve coverage, the tiles are allocated “time first”
 - Tile hopping in different subframes
 - Details in the next slides
- ❑ ACK/NACK can also be transmitted with data
- ❑ Support non-coherent detection on ACK/NACK channel

16m ACK/NACK Control Tile

- ❑ Non-coherent detection
- ❑ 1 control PRU shared by 18 ACK/NACK channel
- ❑ Each FMT (2x6) consists of two 2x3 blocks
- ❑ Each 2x3 block is shared by 6 ACK channels with CDM
 - 1st 2x3 block contains a sequence from set A
 - 2nd 2x3 block contains a sequence from set B
- ❑ 3 FMTs are spread in frequency for diversity

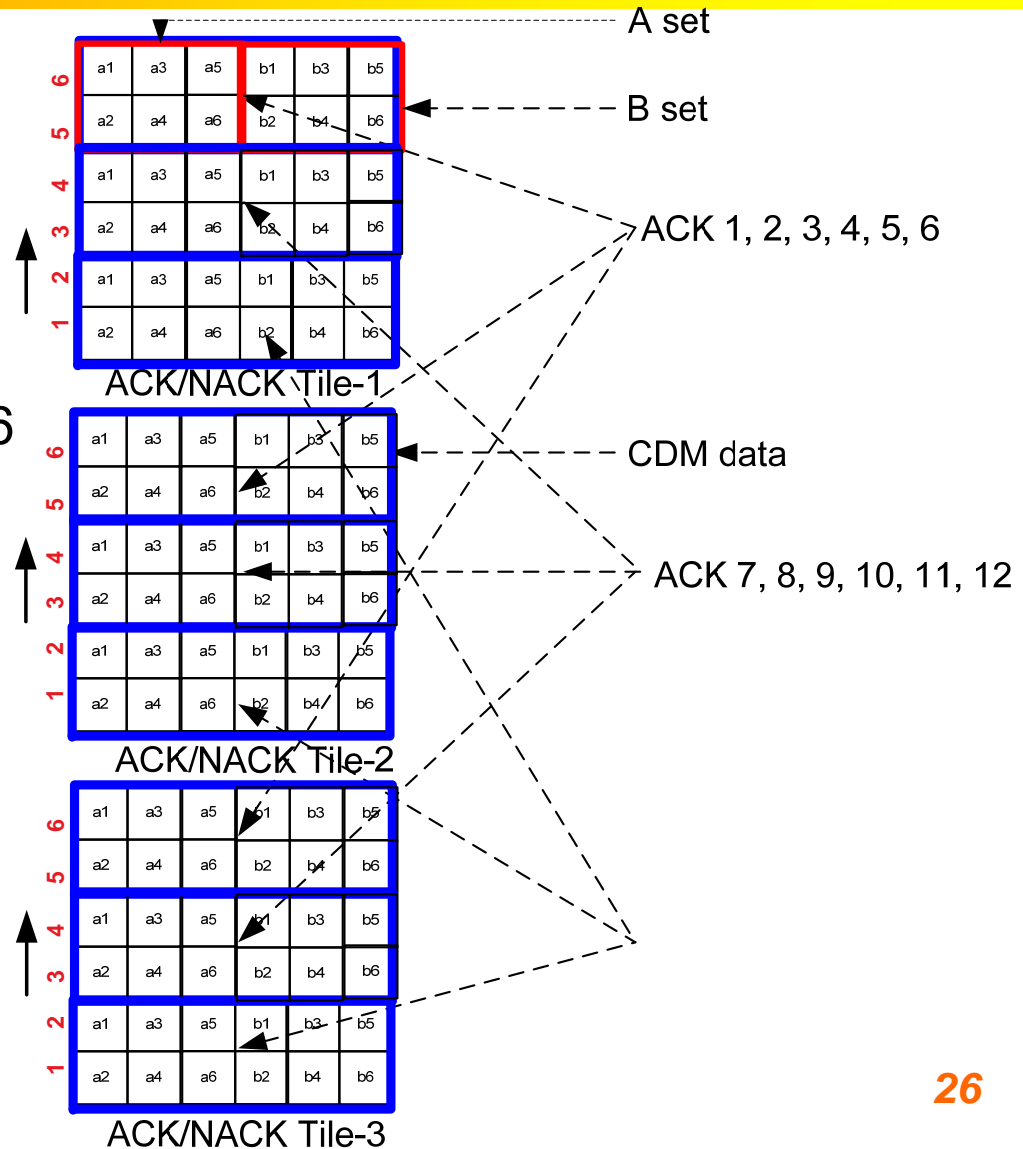

Sequence and Symbol Mapping

- For partially loaded cells users are allocated sequences in order from **U1** to **U6**
- Each user has two sequences: ACK & NACK

$$\begin{aligned}
 Q_0 &= 1 \\
 Q_1 &= -1 \\
 Q_2 &= j \\
 Q_3 &= -j \\
 Q_4 &= \exp(-j2\pi/3) \\
 Q_5 &= \exp(j\pi/3) \\
 Q_6 &= \exp(2\pi/3) \\
 Q_7 &= \exp(-j\pi/3) \\
 Q_8 &= \exp(-j5\pi/6) \\
 Q_9 &= \exp(j\pi/6) \\
 Q_{10} &= \exp(j5\pi/6) \\
 Q_{11} &= \exp(-j\pi/6)
 \end{aligned}$$

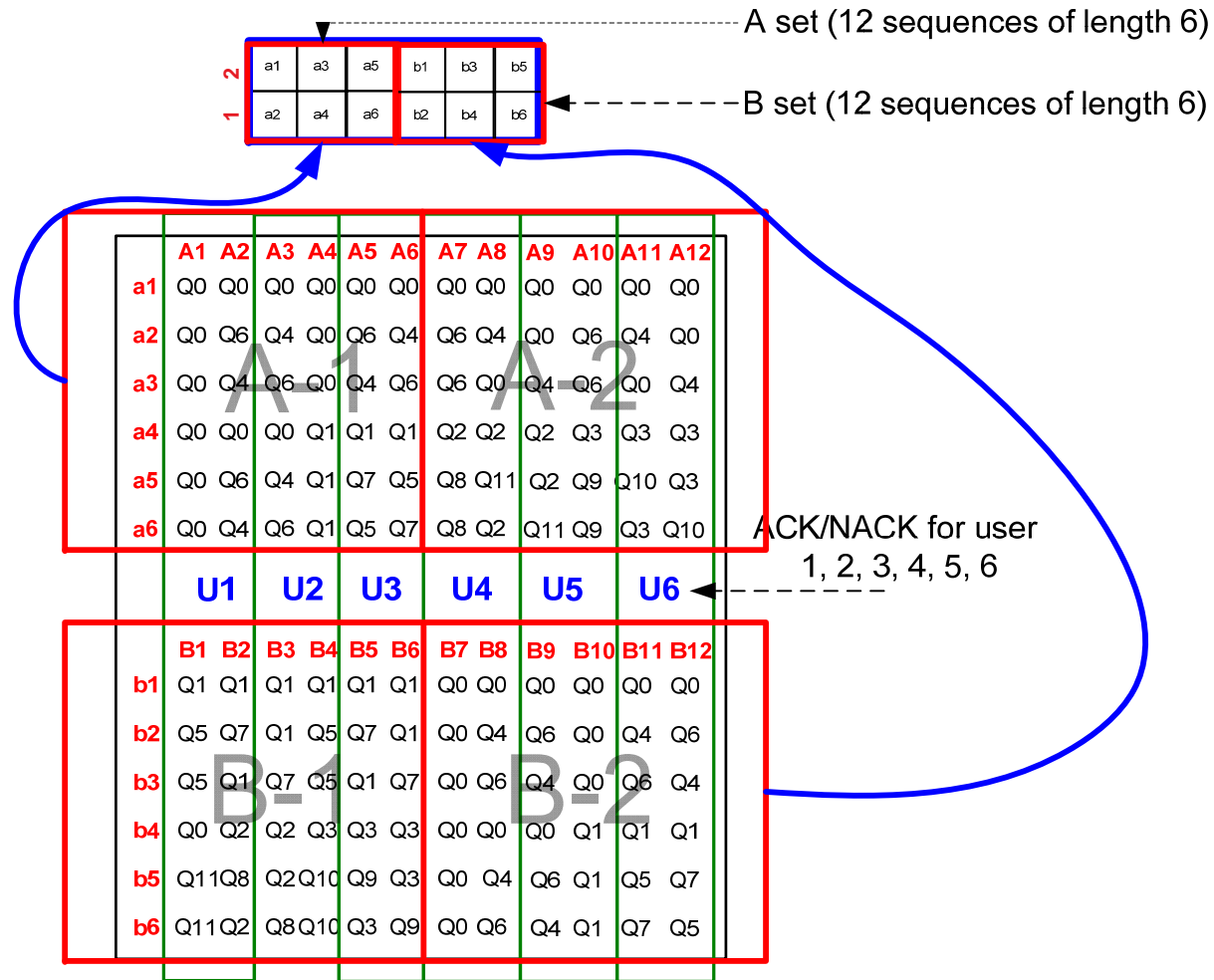

Cross sequence interference

- ❑ Twelve 12-symbol sequences to transmit ACK/NACK for up to 6 users
 - E.g. Two sequence in U1, ACK/NACK for user-1
- ❑ Low cross sequence interference for slow-fading channel
 - Twelve sequences are mutually orthogonal
- ❑ Low cross sequence interference for fast-fading channel
 - Four sets of orthogonal 6-symbol sequences (A-1, A-2, B-1, B-2)
 - Cross interference between any pair of sequences from A-1 and A-2 is low
 - Cross interference between any pair of sequences from B-1 and B-2 is low
 - Only requires channel to be time-coherent over 3 OFDM symbol-time
 - Robust design for high speed MS
- ❑ Users should be allocated in the order from U1 to U6 to minimize the cross user interference for high speed MS

16m ACK/NACK Control Tile Allocation

- ❑ 3 control tiles are allocated for each control PRU
- ❑ Tiles are allocated time-first
 - Link budget advantage in taking full advantage of MS tx power
 - Improved coverage

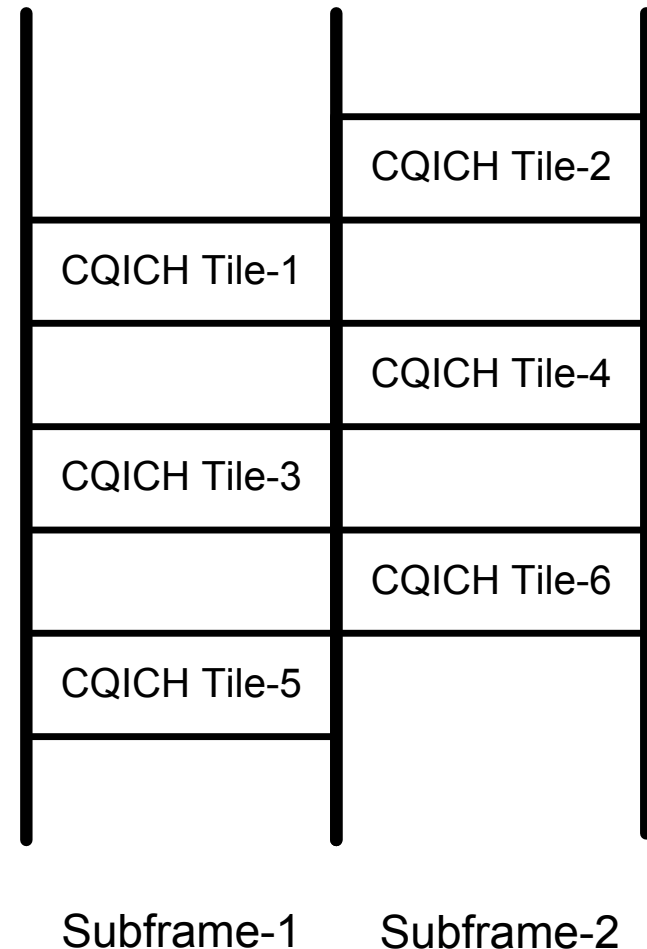

16m ACK/NACK Detection

- ❑ ACK: packet has been received correctly
- ❑ NACK: packet has been received, but incorrectly
- ❑ DTX: DL allocation signal might be missed by MS, or MS ACK/NACK signal is missed

Support Subframe Bundling

- ❑ Multiple DL subframes can be bundled together
- ❑ One ACK/NACK is assigned for each DL allocation across the bundled subframes
 - One allocation corresponds to one DL allocation message
 - 1-bit for SCW
- ❑ Location of ACK/NACK is indicated in DL resource allocation → DL allocation index
 - ACK/NACK for persistent allocation should be allocated before regular allocations
 - DL allocation index should include number of persistent allocations

Link Simulation Parameters

Parameter	Value
NFFT	1024
Carrier frequency	2.6 GHz
# Tx antennas	1
# Rx antennas	2
Antenna spacing	4 λ
Receiver	correlator for ACK
Channel model	PB3, VA120, VA350

ACK performance

ACK miss

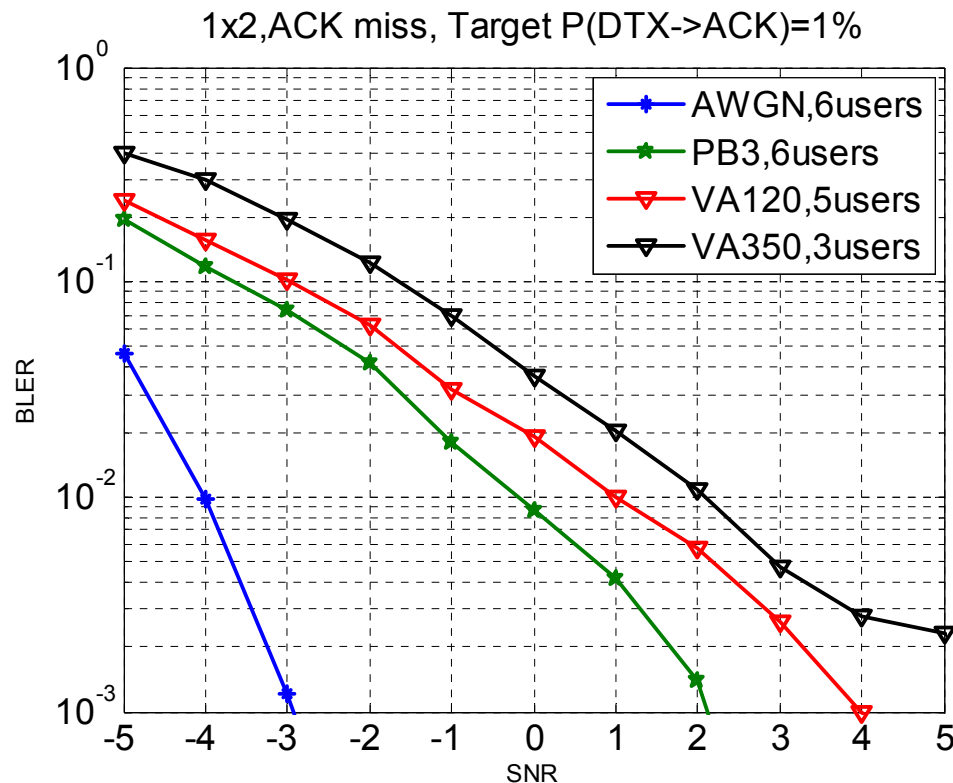

- ❑ MOT design avoids interference floor at high speed
- ❑ Performance can be further improved with more advanced receiver

ACK performance

□ VB3

1x2,6users,ACK miss,VB3

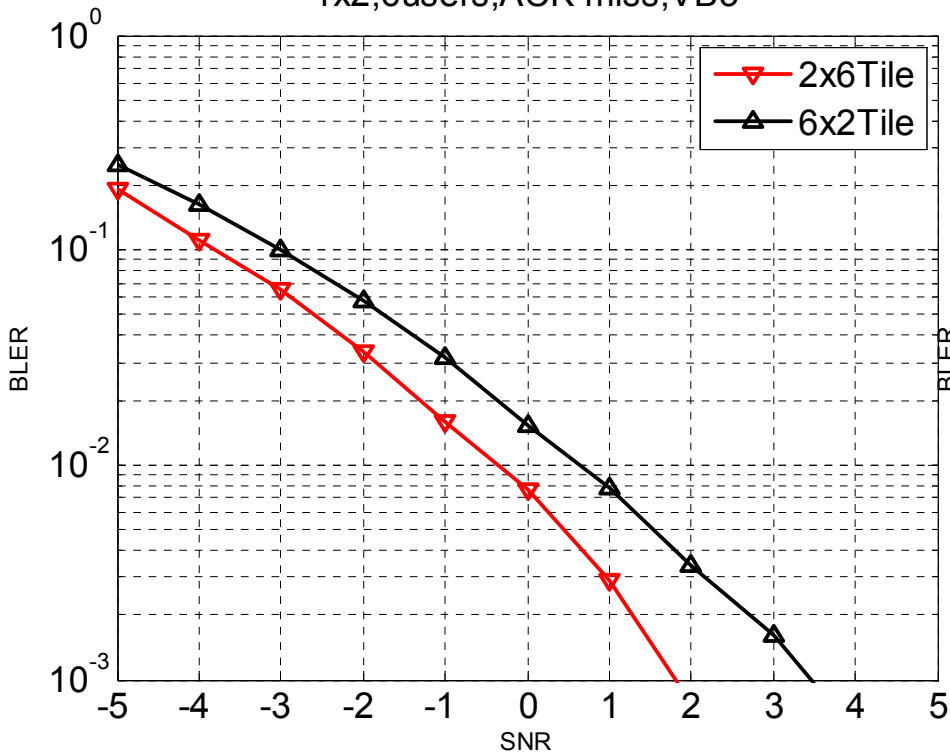

□ HT3,3users

1x2,3users,ACK miss,HT3

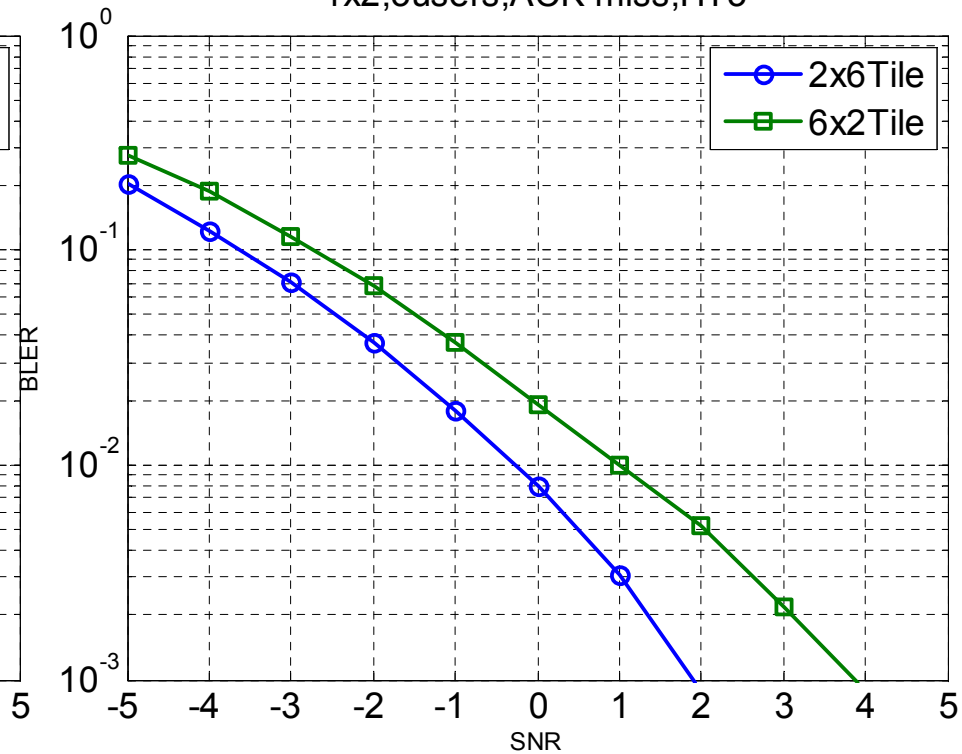

Performance Summary

- ❑ In general agreement of using non-coherent design for ACK/NACK
- ❑ Proposed complex sequences have minimum cross user interference at high speed
 - Orthogonal over 2×3 block if less than 3 users
 - Slight increasing of cross user interference if more than 3 users

Bandwidth Request Indicator Channel

16m Bandwidth Request Channel Design

- ❑ Bandwidth request channel prefer to have same PHY structure for green field mode (16m only) and legacy mode (FDM with legacy UL PUSC)
 - Simplify transmitter and receiver design w/o too many operation modes and configurations
 - Same design philosophy as UL fast feedback channel and HARQ feedback channel
- ❑ Bandwidth request indicator is transmitted using a similar control channel structure as UL HARQ feedback (slide-17)
- ❑ 12 users per 2x6 tile is supported to transmit 1-bit/user BWR indicator