

Title: Improvements in System Performance due to simultaneous transmission of E-MBS and Unicast

Document Number: S802.16m-08/361

Date Submitted: May 06 2008

Source: Improvements in System Performance due to simultaneous transmission of E-MBS and Unicast

Kaushik Josiam, Farooq Khan, Jiann-an Tsai, Zhouyue Pi Voice:+972 761-7000 k.josiam@samsung.com

Samsung Telecommunications America

1301 E. Lookout Dr

Richardson TX 75082

Venue:

Session #55, 12-15 May 2008

Base Document: C802.16m-08/361.pdf

Purpose: To discuss and adopt the superposition coding scheme for broadcast and unicast symbols into 802.16m SDD .

Notice

This document does not represent the agreed views of the IEEE 802.16 Working Group or any of its subgroups. It represents only the views of the participants listed in the "Source(s)" field above. It is offered as a basis for discussion. It is not binding on the contributor(s), who reserve(s) the right to add, amend or withdraw material contained herein.

Release:

The contributor grants a free, irrevocable license to the IEEE to incorporate material contained in this contribution, and any modifications thereof, in the creation of an IEEE Standards publication; to copyright in the IEEE's name any IEEE Standards publication even though it may include portions of this contribution; and at the IEEE's sole discretion to permit others to reproduce in whole or in part the resulting IEEE Standards publication. The contributor also acknowledges and accepts that this contribution may be made public by IEEE 802.16.

Patent Policy:

The contributor is familiar with the IEEE-SA Patent Policy and Procedures:<<http://standards.ieee.org/guides/bylaws/sect6-7.html#6>> and <<http://standards.ieee.org/guides/opman/sect6.html#6.3>>.

Further information is located at <<http://standards.ieee.org/board/pat/pat-material.html>> and

<<http://standards.ieee.org/board/pat>>.

Improvements in System Performance due to **simultaneous transmission of E-MBS and Unicast**

Kaushik Josiam, Farooq Khan,
Jiann-an Tsai, Zhouyue Pi
Samsung Telecommunications America
Richardson, TX, USA

Superposition Coding

Of broadcast and unicast signals

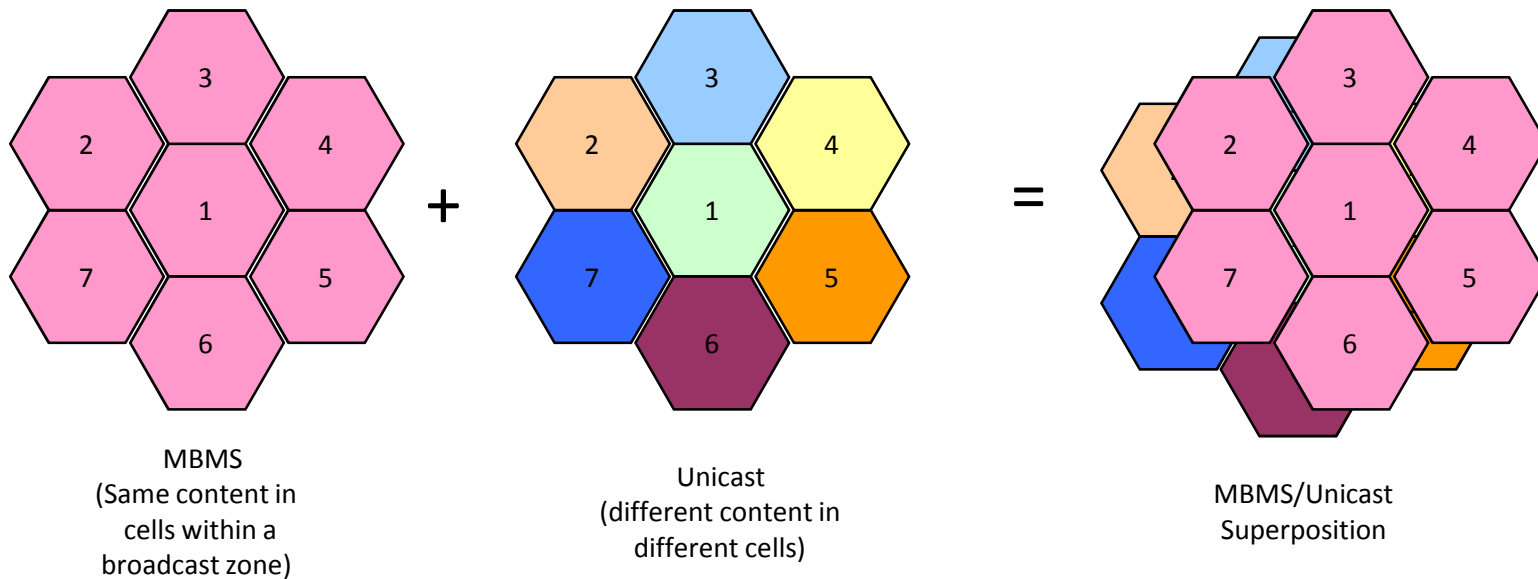

Spectrum Efficiency target for MBMS in LTE: 1 bps/Hz

Geometry: Unicast vs. Broadcast

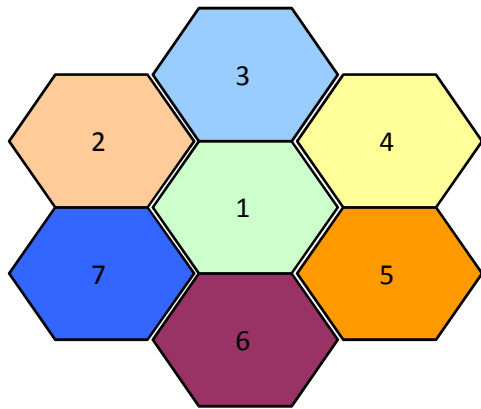

Unicast
(different content in
different cells)

$$SINR_{unicast} = \frac{P}{fP + N_0}$$

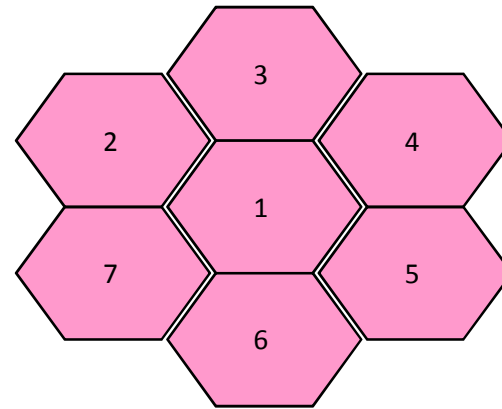

MBMS
(Same content in
cells within a
broadcast zone)

$$SINR_{broadcast} = \frac{KP}{N_0}$$

Unicast traffic is **interference limited**; broadcast is not.

Interference limited Unicast

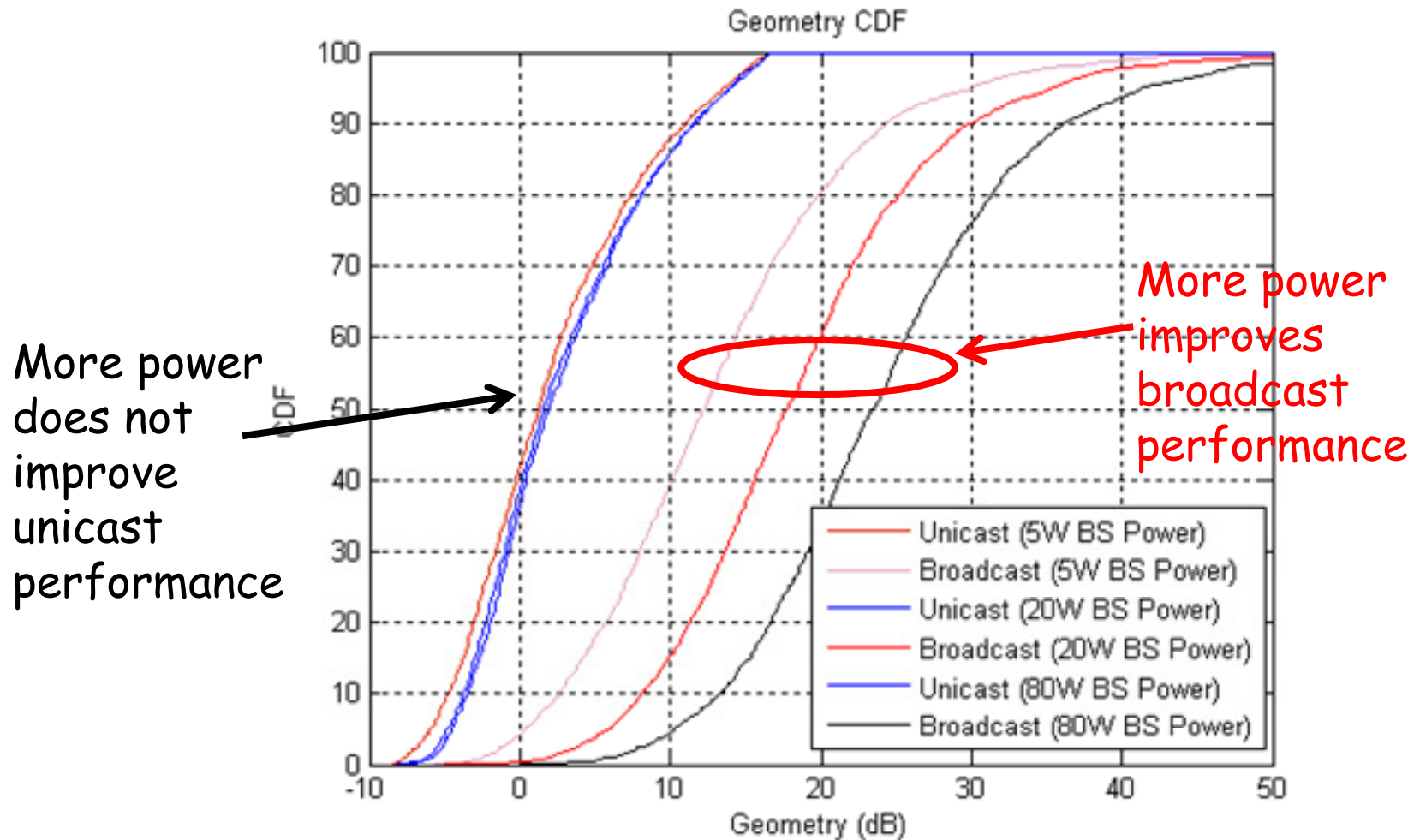

Superposition MIMO

Split power budget between unicast and MBMS signals

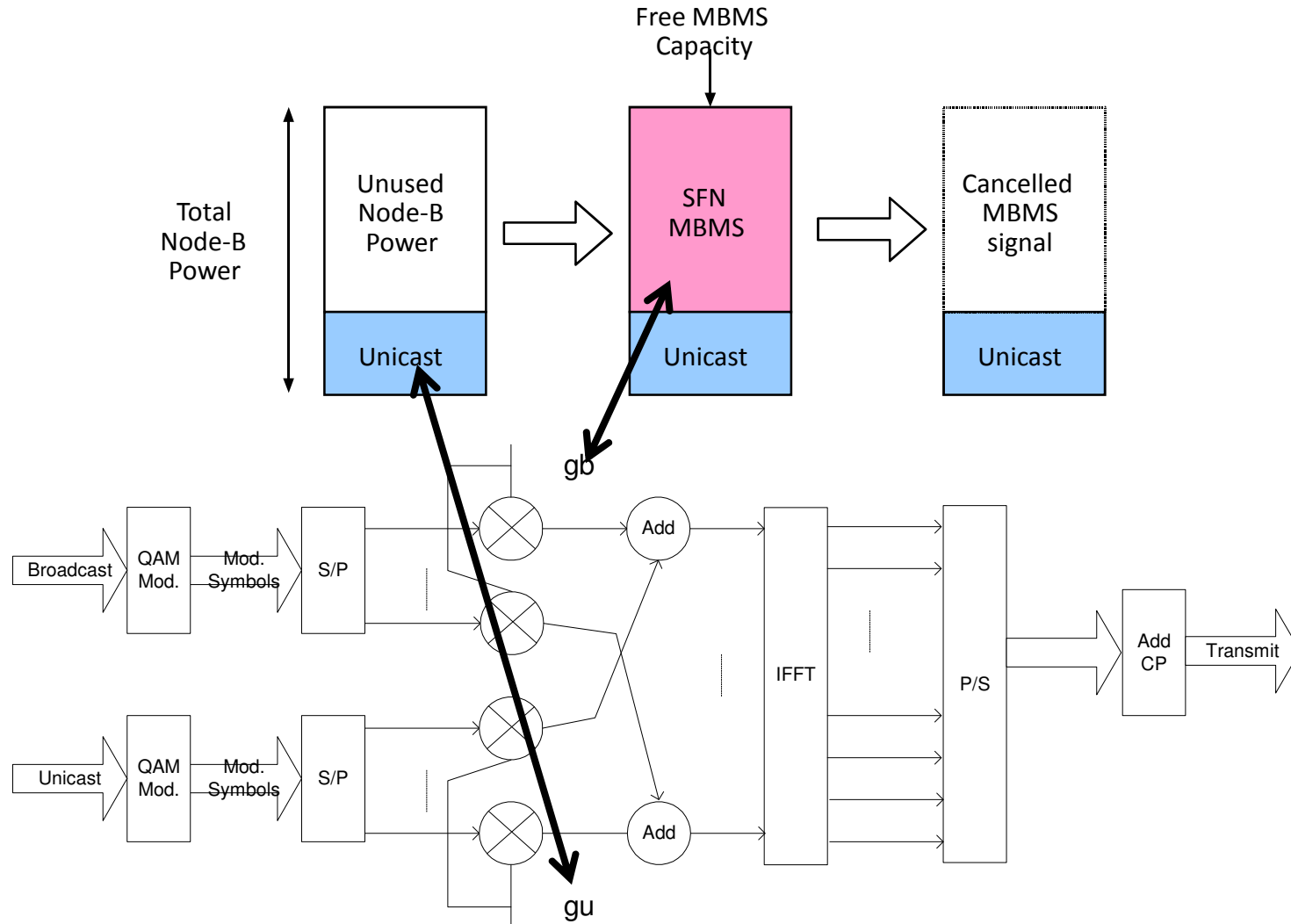

Interference cancellation

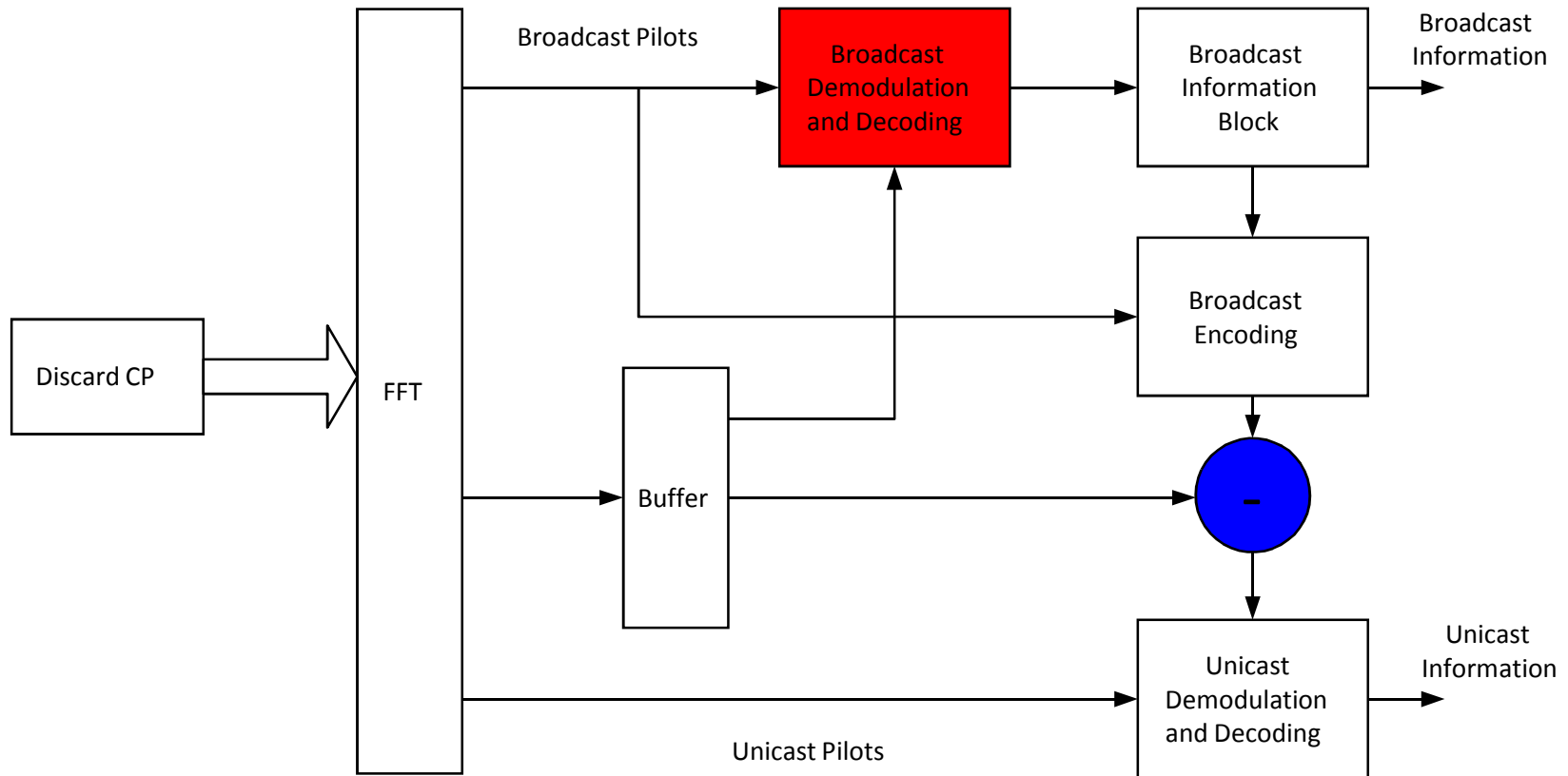

Decode broadcast MBMS signal first & cancel it from received signal to decode unicast symbols

Spectral Efficiency with superposition

$$C_{broadcast} = \log_2 \left(1 + \frac{\sum_i P_{Bi}}{\sum_i P_{Ui}} \right) \approx \log_2 \left(1 + \frac{P_B}{P_U} \right) \quad [b/s/Hz]$$

For broadcast, the SINR is proportional to the power ratio P_B/P_U

$$C_{unicast} = \log_2 \left(1 + \frac{P_U}{I_{BSIC} + fP_U + N_0} \right) \quad [b/s/Hz]$$

Residual interference due to imperfect interference cancellation



Noisy channel estimates

Spectral Efficiency curve - I

Perfect channel estimates for both broadcast & unicast signals

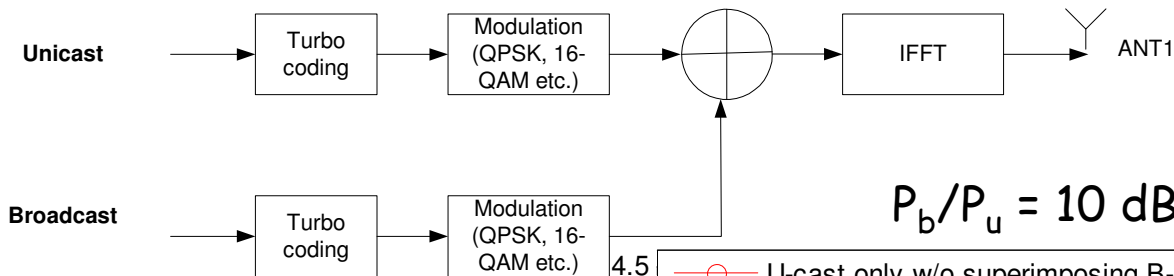

Single stream unicast and broadcast traffic

No deterioration in unicast rates due to superposition

QPSK + 2/3 coding rate: 4/3 bps/Hz

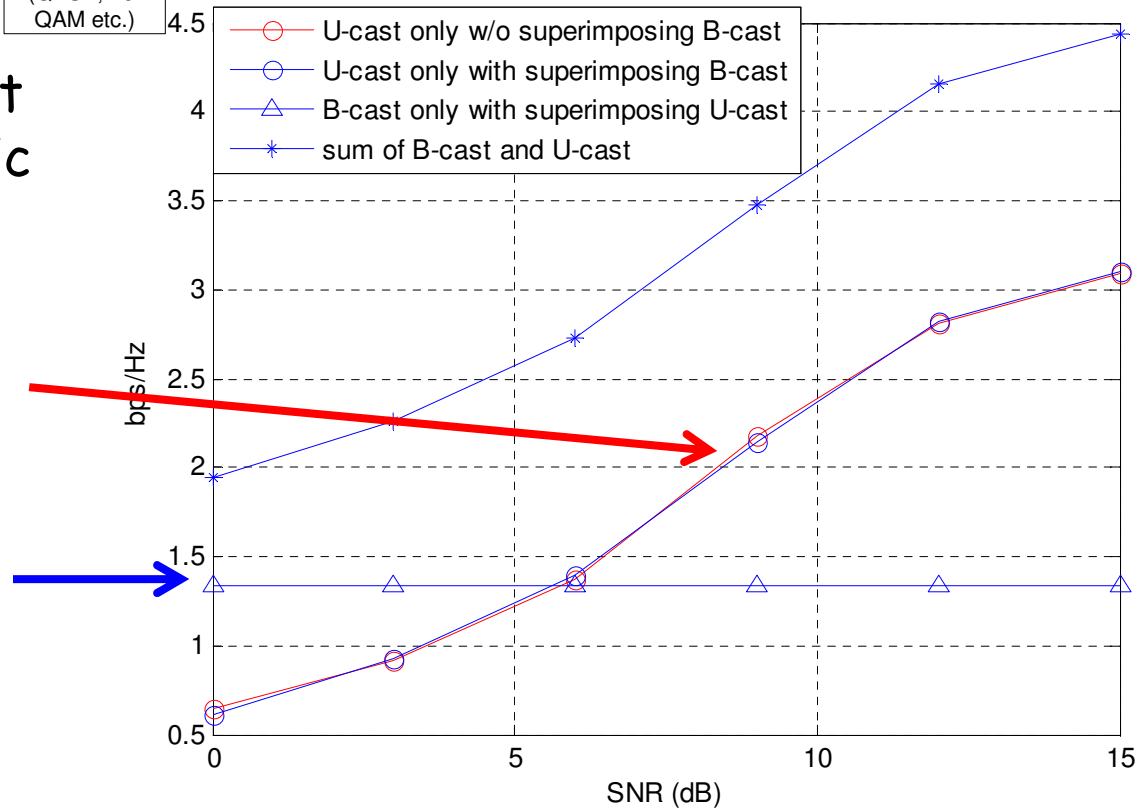

Spectral Efficiency curve - II

Imperfect channel estimates for broadcast

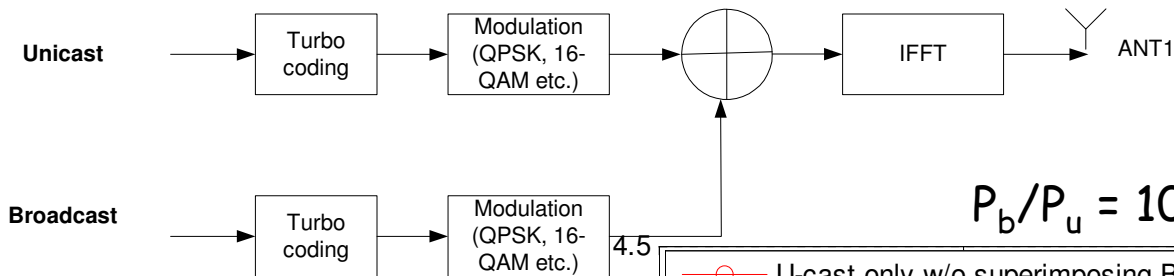

Single stream unicast and broadcast traffic

Small deterioration in unicast rates due to superposition

QPSK + 2/3 coding rate: 4/3 bps/Hz

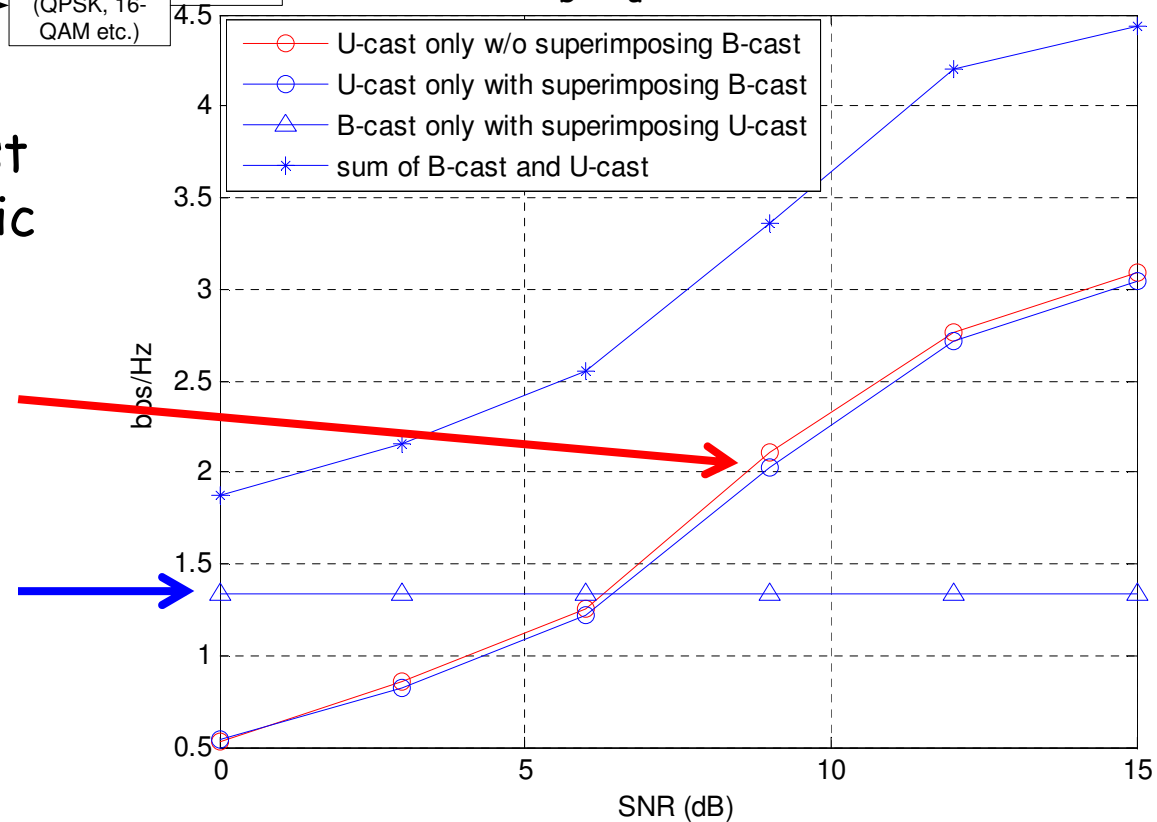

Superposition MIMO

Two streams for unicast and a single stream for MBMS

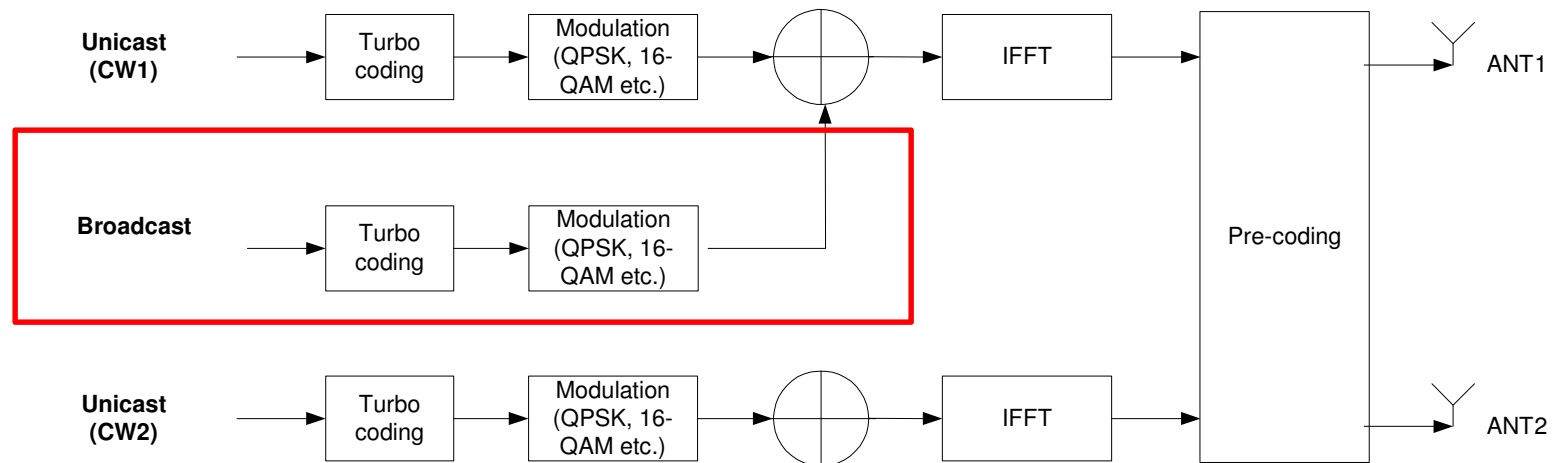

Superposition MIMO

Two streams for both unicast and MBMS

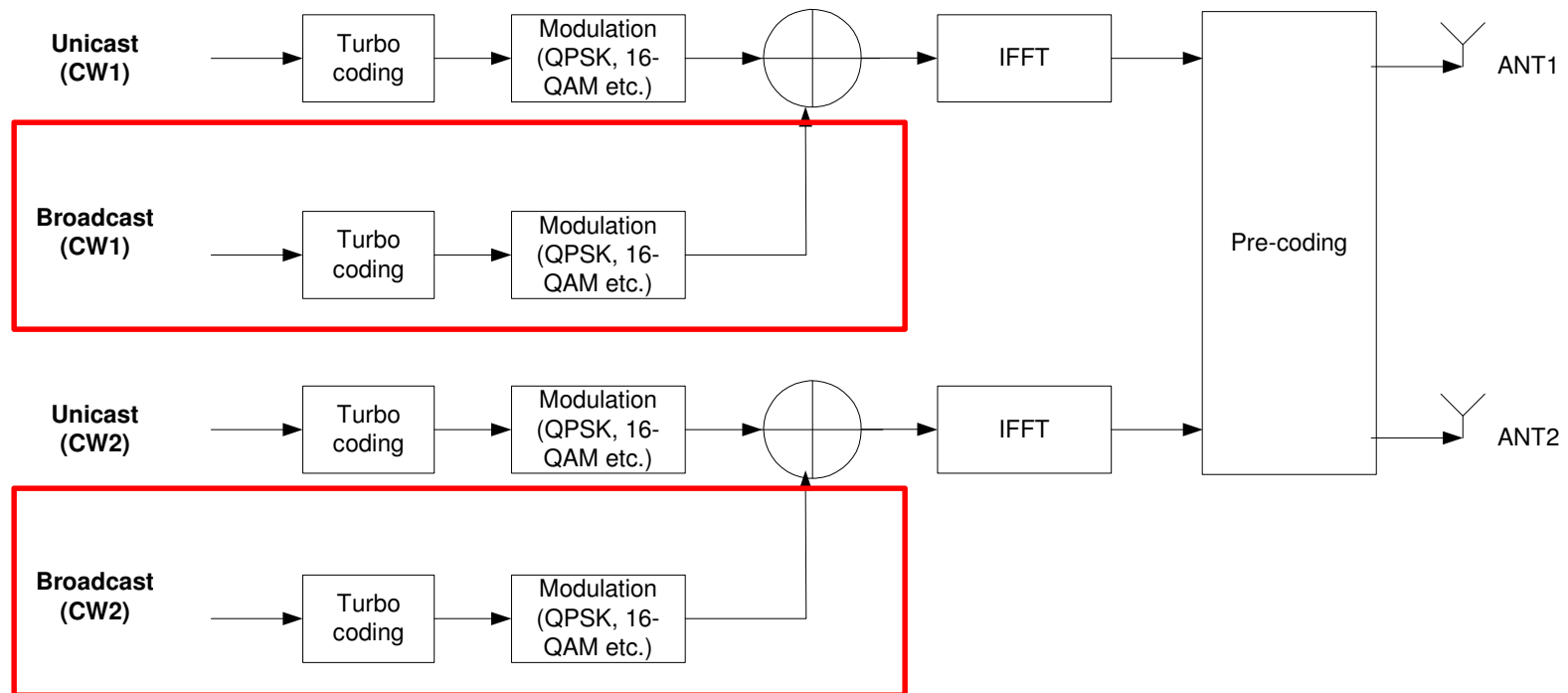

Superposition MIMO

Receiver Operation: **Decode MBMS streams** first and then decode Unicast streams

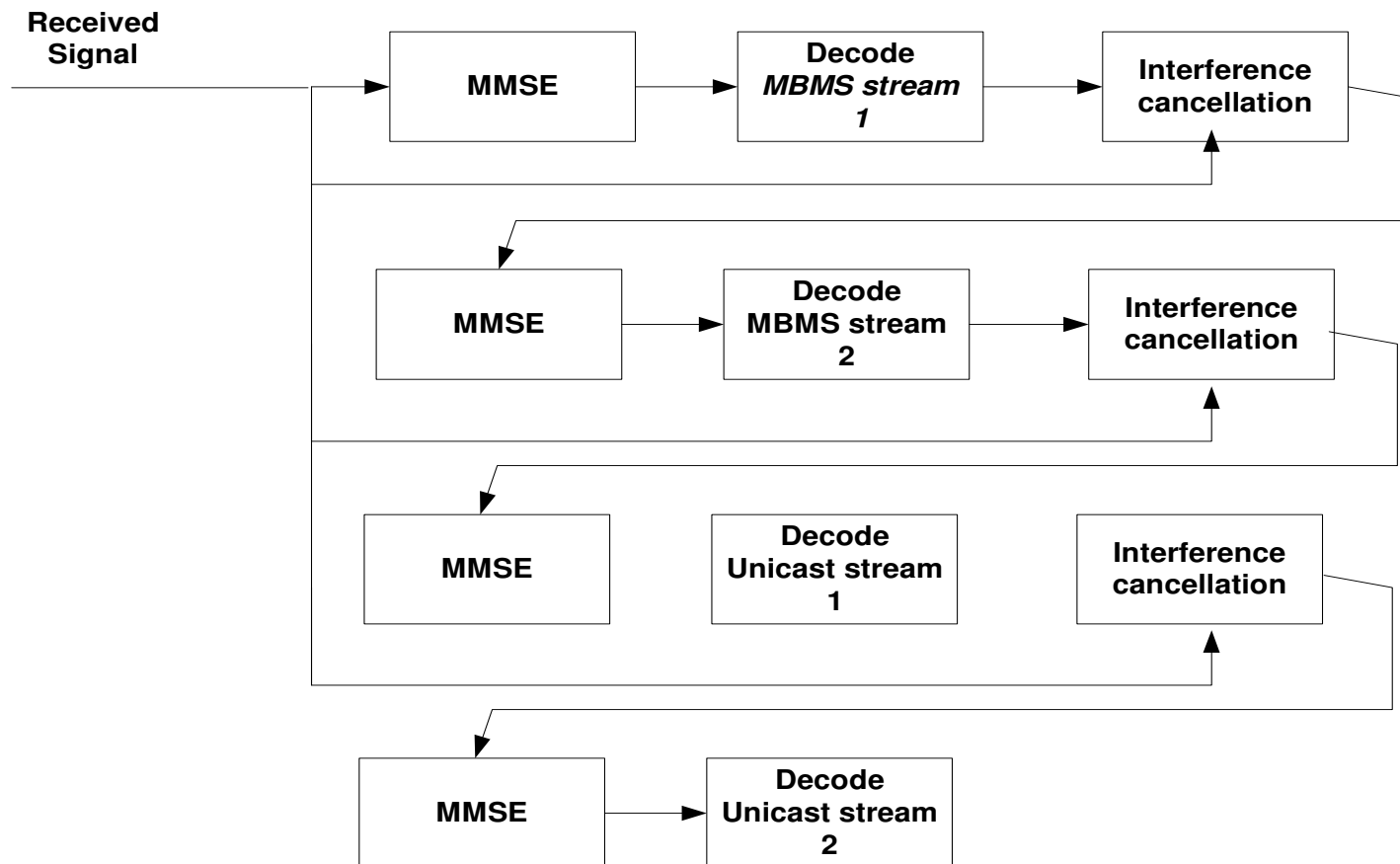

System Simulations: Throughput

> 100% improvement in throughput

	Unicast THP	Broadcast THP	Total	5% User THP
Base Line w/o MBMS Superposition	1.90	0	1.90	0.0667
Base Line with MBMS Superposition	1.89	2	3.89	0.0677
PARC w/o MBMS Superposition	2.17	0	2.17	0.0708
PARC with MBMS Superposition	2.16	2.66	4.82	0.0690

System View: Fairness

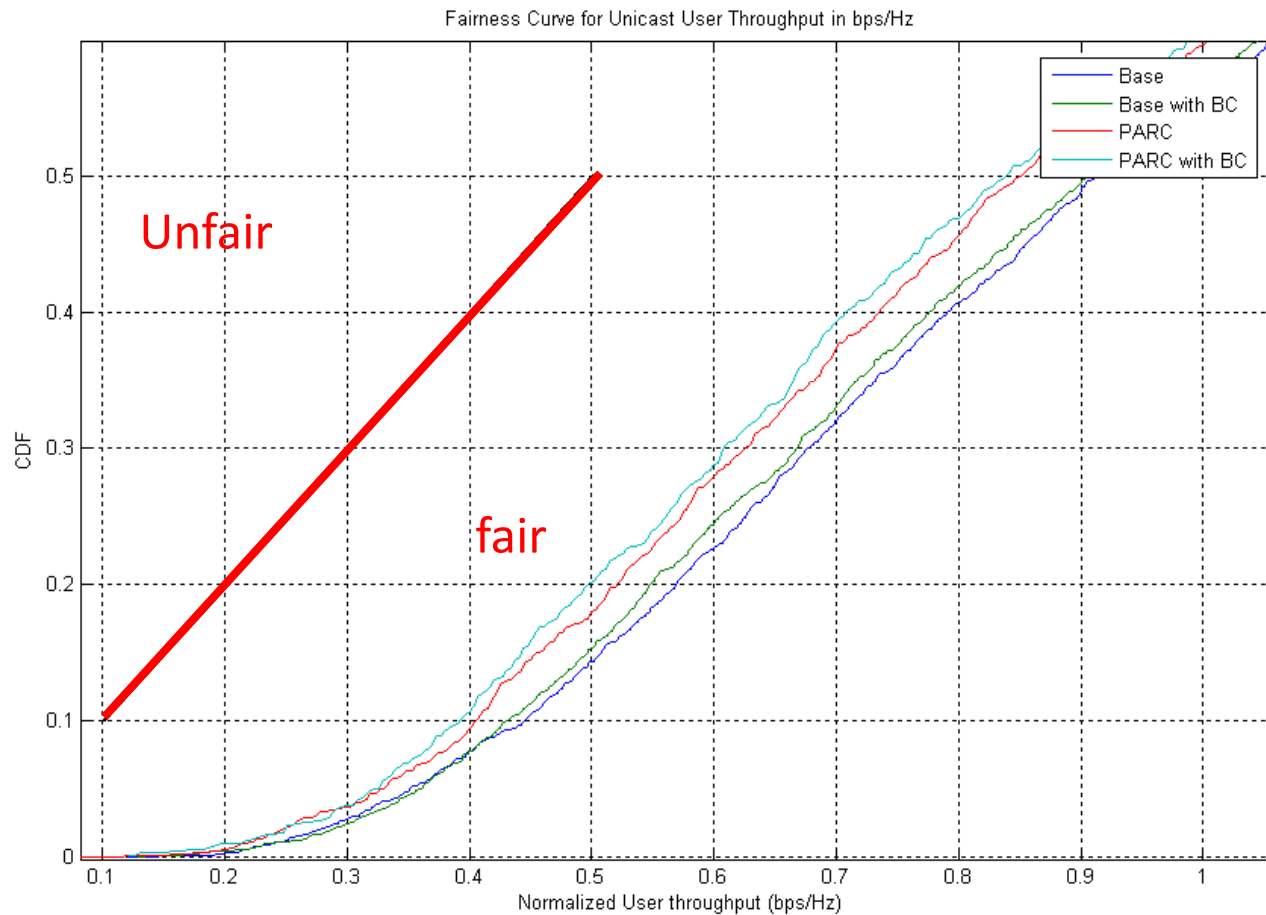

Summary

- More bang for the bucks
 - For a little extra power, superposition achieves **improves overall system throughput and spectral efficiency** without adversely affecting unicast rates
 - Simple receiver operation – MMSE with SIC
- **Slight loss in unicast rates due to imperfect interference cancellation**
 - Impact due to imperfect channel estimation
 - Mitigate loss by using a dense packing of power boosted broadcast reference signals.