



Updated results of PIE metrics calculations

Presented by Yu Sun

IEEE 802.3aq 10GBASE-LRM Task Force – November, 2004

Outline

- The dependency of PIE metrics on input pulse shape and propagation distance were presented in Ottawa meeting
- The statistics of PIE metrics for Cambridge 81 fiber was presented
- PIE metrics of new 108 fiber are calculated

Simulation setup and PIE calculation

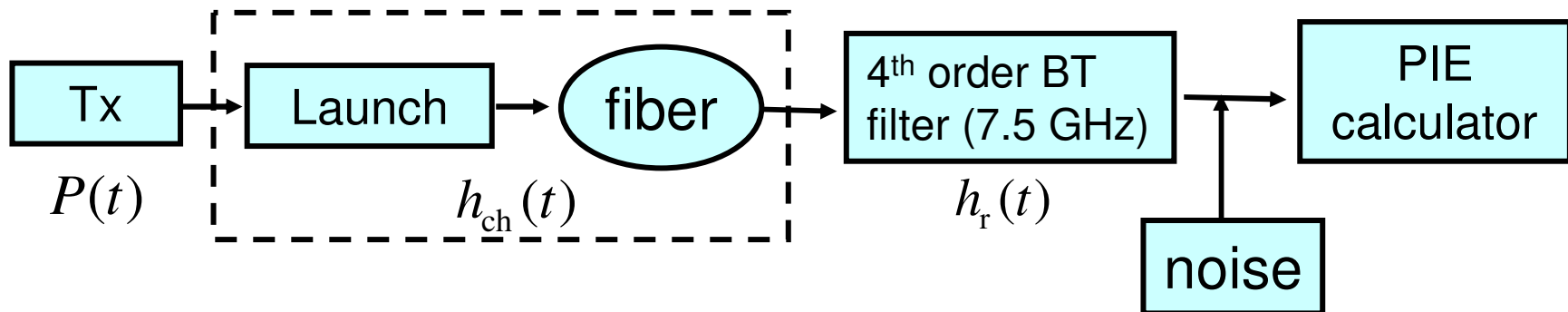

- Channel is simulated using **Cambridge new release (108 fibers)**
- Composite pulse response $h(t) = p(t) * h_{ch}(t) * h_r(t)$
- Noise is a constant (bhoja_1_0704.pdf)

$$\sigma^2 = 10^{(\text{ESNR} - 2 * \text{optical dispersion penalty}) / 10}, \text{ where}$$

$$\text{ESNR} = 17\text{dB (BER} = 10^{-12}\text{)};$$

$$\text{optical dispersion penalty} = 6\text{dB}$$

Effect of input pulse width on PIE metrics

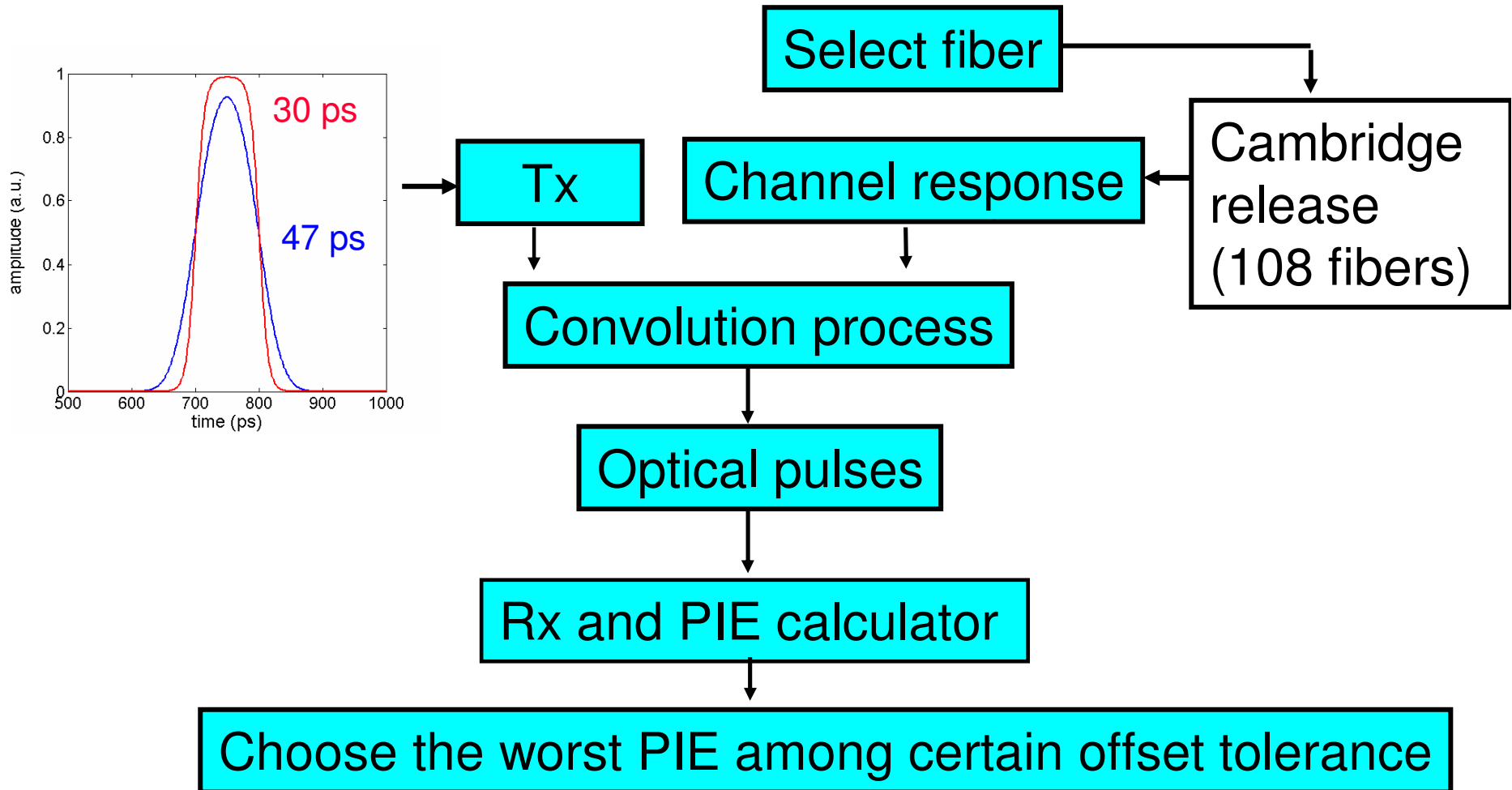

The process is repeated for all 108 fibers.
30 ps rising time is used in all simulations

IEEE 802.3aq 10GBASE-LRM Task Force – November, 2004

Worst pulse examples (220m)

Offset launch

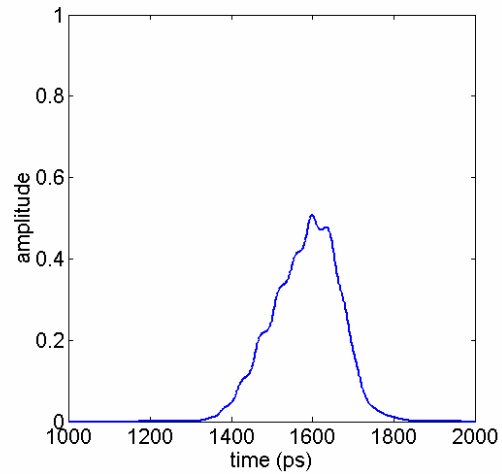

Center launch

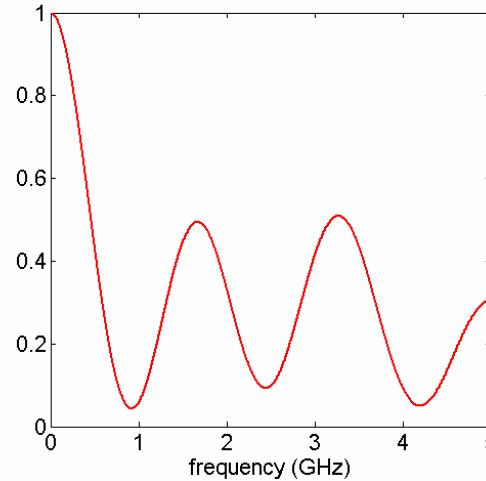
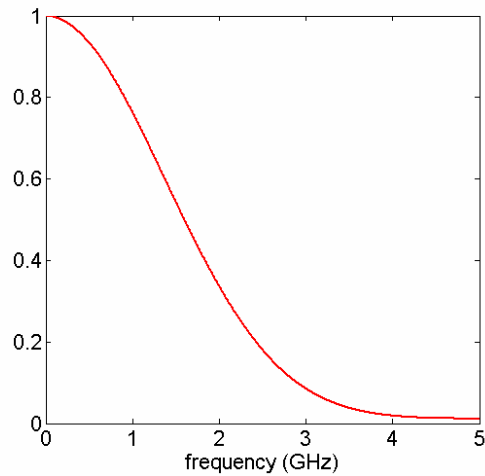
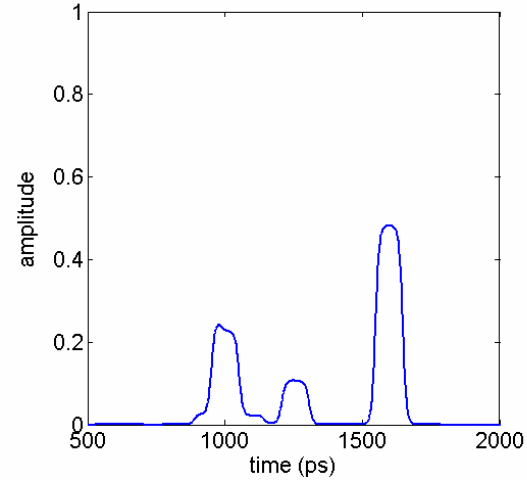

PIE metrics of 220 m fiber

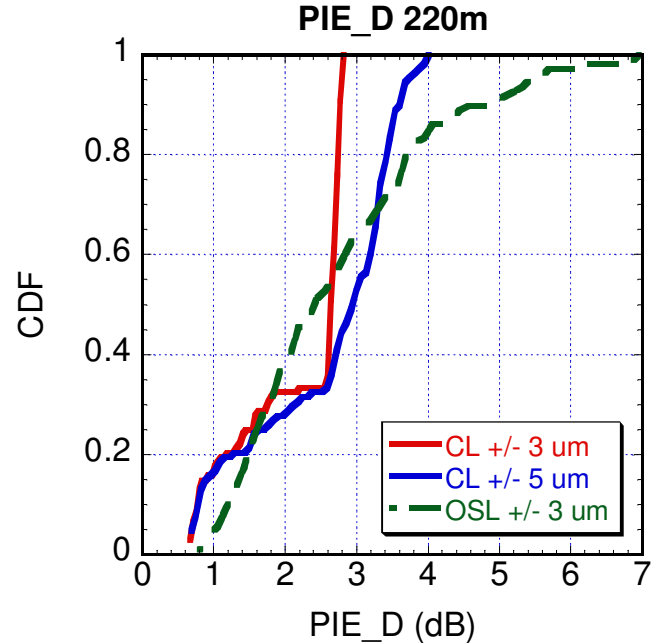
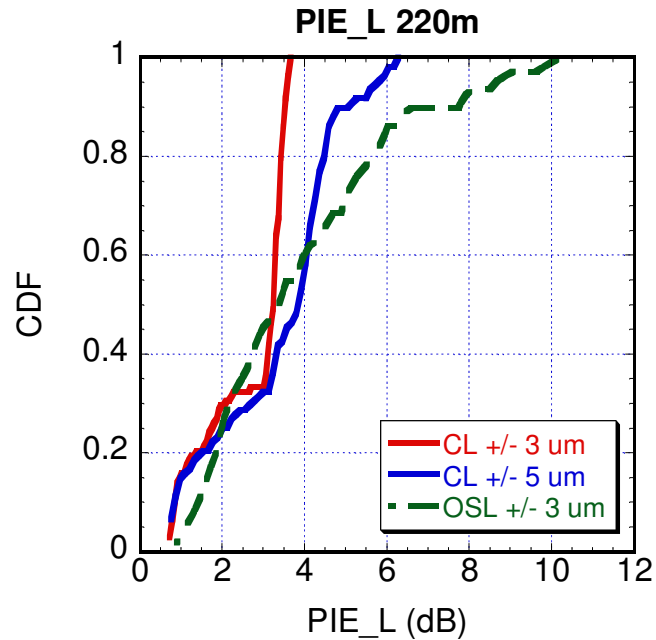

% of < 4.5 dB	PIE_L	PIE_D
CL +/- 3 μm	100 (100)	100 (100)
CL +/- 5 μm	86 (100)	100 (100)
OSL +/- 3 μm	65 (92)	89 (100)

Red number: percentage of <4.5 dB for 81 fibers

IEEE 802.3aq 10GBASE-LRM Task Force – November, 2004

PIE metrics of 300 m fiber

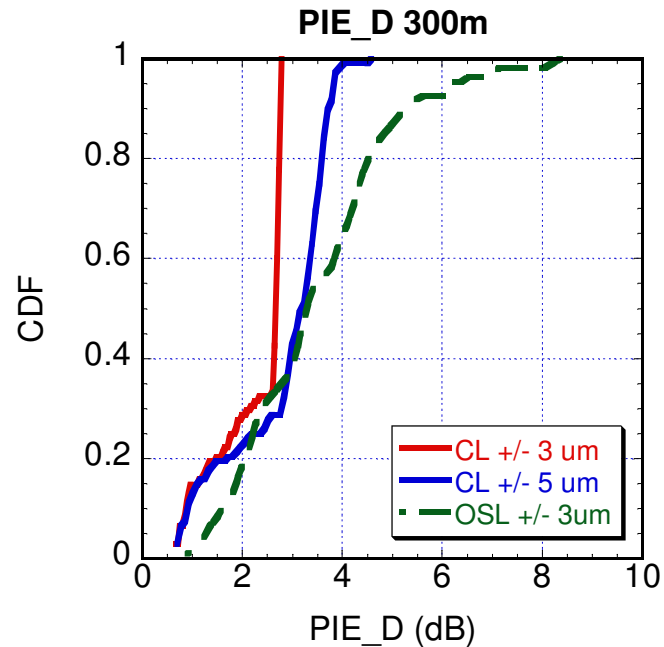
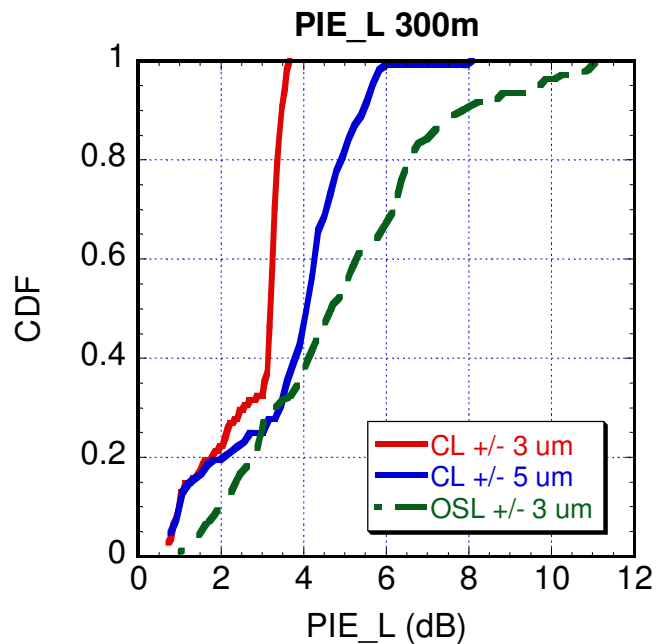

% of < 4.5 dB	PIE_L	PIE_D
CL +/- 3 μm	100 (100)	100 (100)
CL +/- 5 μm	71 (100)	99 (100)
OSL +/- 3 μm	47 (70)	79 (95)

Red number: percentage of <4.5 dB for 81 fibers

IEEE 802.3aq 10GBASE-LRM Task Force – November, 2004

Proposed multimode fiber link

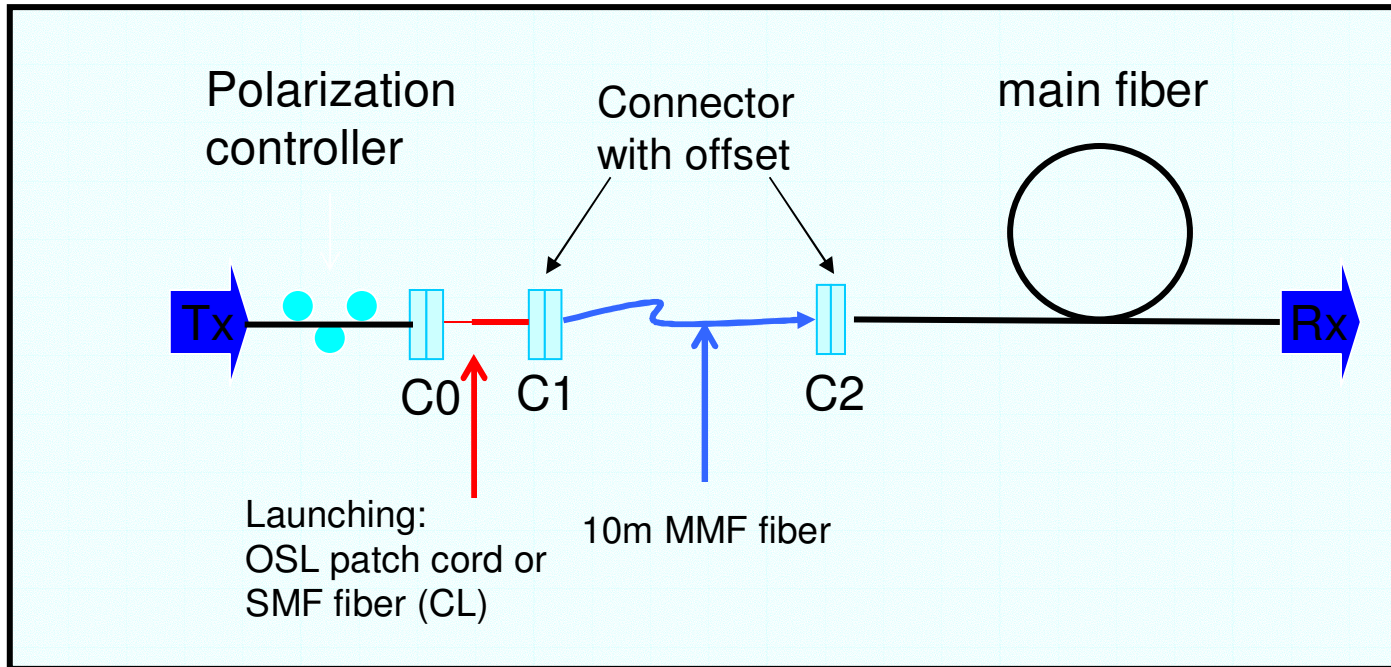

Case I : $C1 = C2 = 5 \mu\text{m}$

Case II : $C1 = C2 = 7 \mu\text{m}$

Baseline pulse shape comparison

— Optium in-house simulator
- - - Cambridge release 3.1

Fiber 15, offset 17 μm

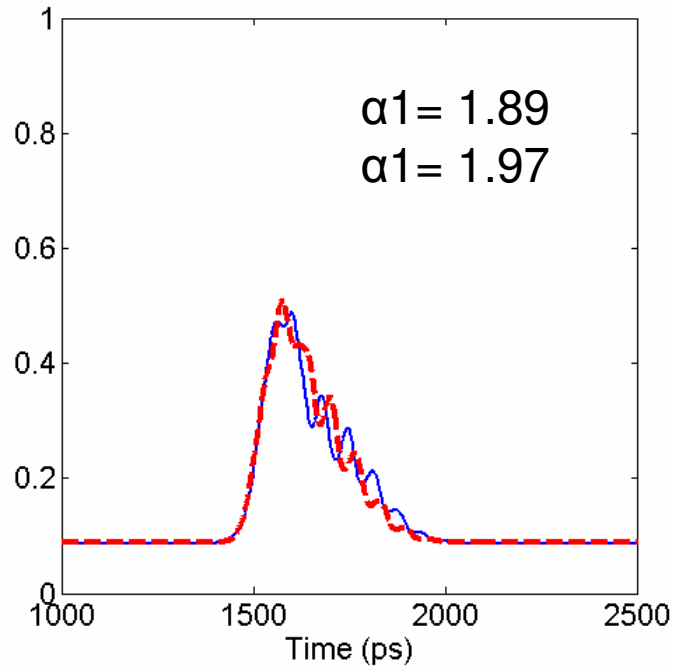

Fiber 63, offset 17 μm

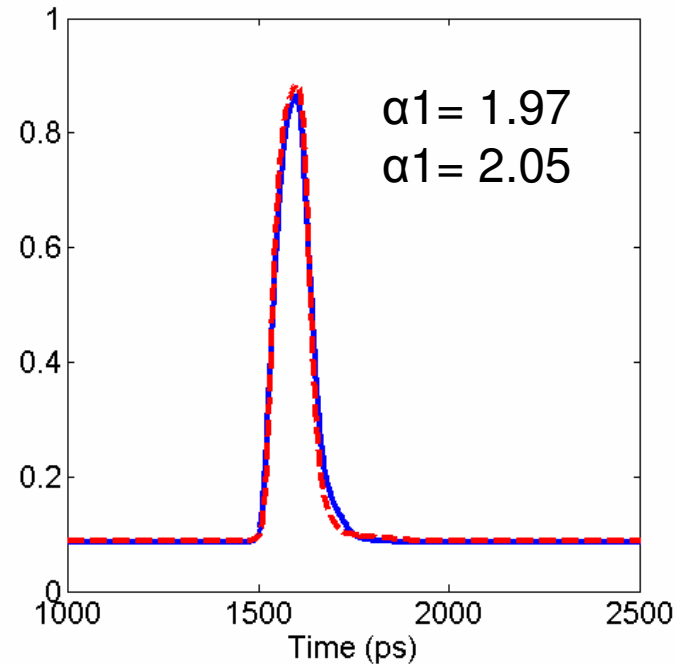

18 modal groups are included

Channel modeling using in-house simulator

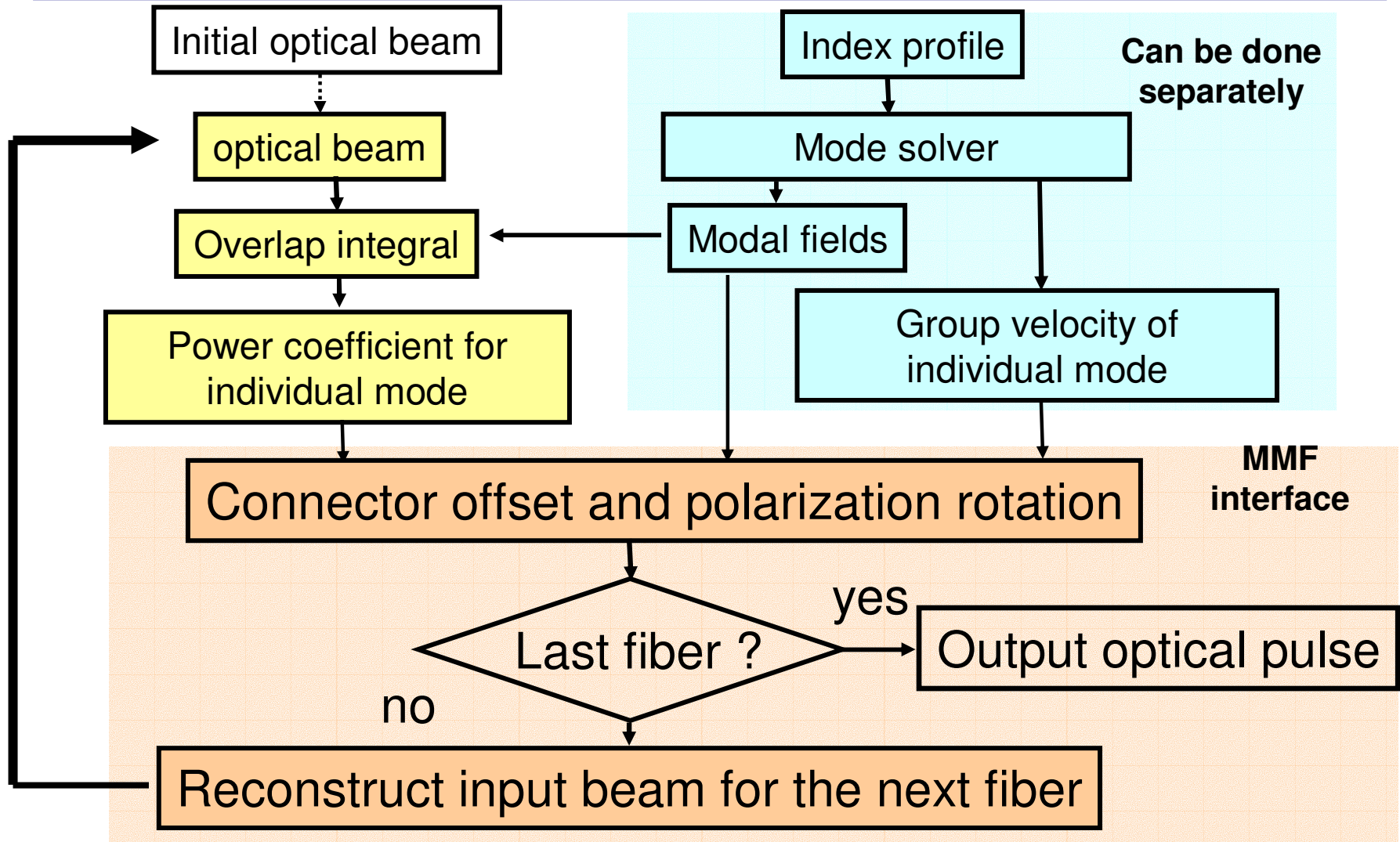

Comparison of PIE_D metrics

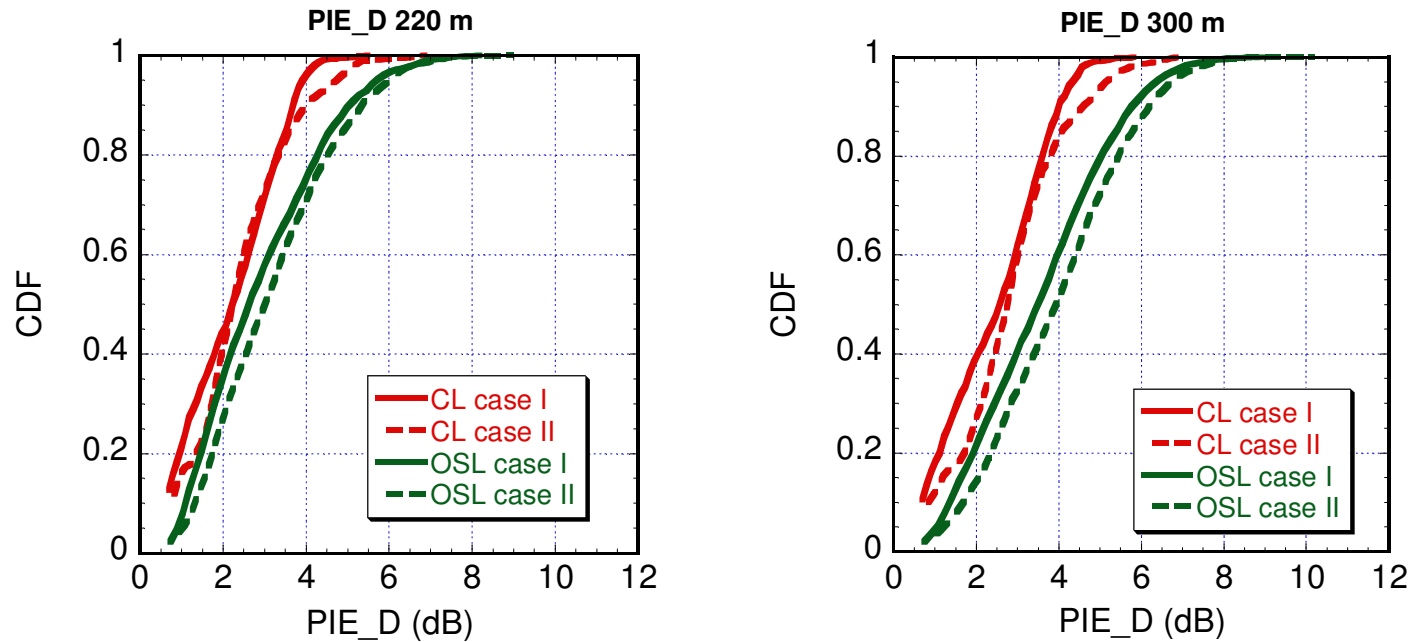

% of < 4.5 dB	220m	300m
CL case I	99.2	97.9
CL case II	93	89
OSL case I	84.2	72
OSL case II	79	60

Conclusion

- PIE metrics of offset launch degrade as the distance increase.
- PIE metrics for center launch is not sensitive to the change of fiber length.
- With multiple offset connectors in the link, center launch experience less PIE penalty