

1 TSN Industrial Automation Use Cases v0.1

2 Contributor group

This Use Case Document

McCall, David <david.mccall@intel.com>

Initial Use Case Document from 2019

Belliardi, Rudy <rudy.belliardi@schneider-electric.com>

Dorr, Josef <josef.dorr@siemens.com>

Enzinger, Thomas <thomas.enzinger@br-automation.com>

Essler, Florian <f.essler@beckhoff.com>

Farkas, János <janos.farkas@ericsson.com>

Hantel, Mark <mrhantel@ra.rockwell.com>

Riegel, Maximilian <maximilian.riegel@nokia.com>

Stanica, Marius-Petru <marius-petru.stanica@de.abb.com>

Steindl, Guenter <guenter.steindl@siemens.com>

Wamßer, Reiner <Reiner.Wamsser@boschrexroth.de>

Weber, Karl <karl.weber@beckhoff.com>

Zuponcic , Steven A. <sazuponcic@ra.rockwell.com>

3

4 **Abstract**

5 This document describes use cases for industrial automation, which may be covered by a future
6 project or projects to add functionality to IEC/IEEE 60802 TSN Profile for Industrial Automation.
7 These use cases can guide a specification process: a selection of these use cases would determine
8 WHAT shall be enabled by a future project or projects that specifies HOW to achieve the use cases
9 at the system level of an IA system. Even if a project does not cover the overall system level, the
10 project can enable, or at least do not prevent, the features described in a use case.

11

12 In this first draft (v0.1) use case numbering (and Figure and Table numbering) from [1] (see
13 References) is carried over to aid comparison with that document. New use cases are identified
14 with a preceding "N", e.g. N10. The intention is to renumber (and potentially reorder) the use
15 cases in a future draft.

16 **Log**

17 v0.1 2025-11-10 Working Draft

18 **References**

- 19 [1] Use Cases IEC/IEEE 60802 V1.3
- 20 [2] [“Review of potential use cases for a potential amendment to IEC/IEEE 60802 version 2”](#),
21 contribution to IEC/IEEE 60802 by David McCall, September 2025
- 22 [3] [“Security Use Cases IEC/IEEE 60802”](#), group contribution to IEC/IEEE 60802, April 2022
- 23 [4] [“IEC/IEEE 60802 amendment brainstorming: IA-Controller – Cloud Solution – Configuration
24 Domain”](#), contribution to IEC/IEEE 60802 by Günter Steindl and Dieter Proell, June 2025
- 25 [5] [“IEC/IEEE 60802 Edition 2 Topics”](#), contribution to IEC/IEEE 60802 by Mark Hantel, July 2025
- 26 [6] [“Management proxies for ccA”](#), contribution to IEC/IEEE 60802 by Thomas Enzinger, May
27 2025
- 28 [7] [“60802 – Edition 2 – Some Topics”](#), contribution to IEC/IEEE 60802 by Marius-Petru Stanica,
29 May 2025

30	Content	
31	Contributor group	1
32	Abstract	1
33	Log	2
34	References	3
35	Content.....	4
36	Figures.....	5
37	Tables.....	5
38	1 Terms and Definitions	6
39	1.1 Definitions.....	6
40	1.2 IEEE802 terms	7
41	2 TSN in Industrial Automation	8
42	2.1 Interoperability	9
43	2.2 TSN Domain	10
44	2.2.1 General.....	10
45	2.2.2 Interconnection of TSN Domains	11
46	2.2.2.1 General.....	11
47	2.2.2.2 Bridges (Layer 2).....	12
48	2.2.2.3 Routers (Layer3).....	13
49	2.2.2.4 Application Gateways (Layer7)	14
50	2.3 Synchronization	14
51	2.3.1 General.....	14
52	2.3.2 Universal Time Synchronization.....	15
53	2.3.3 Working Clock Synchronization	15
54	2.4 Industrial automation modes of operation	16
55	2.4.1 Industrial automation traffic types	16
56	2.4.1.1 General.....	16
57	2.4.1.2 Characterization of isochronous cyclic real-time and cyclic real-time	18
58	2.4.2 Bidirectional communication relations	19
59	2.4.3 Control Loop Basic Model.....	20
60	2.5 Industrial automation networks	22
61	2.5.1 Use case 07: Redundant networks	22
62	2.5.2 Use case 09: Wireless	23
63	2.5.3 Use case N10: Multi-Subnet Operation.....	24
64	2.6 Industrial automation machines, production cells, production lines	25
65	2.6.1 Use case 17: Machine to Machine/Controller to Controller (M2M/C2C)	
66	Communication.....	25
67	2.6.2 Use case 18: Pass-through Traffic.....	27
68	2.6.3 Use case 21: Dynamic plugging and unplugging of machines (subnets).....	29
69	2.6.4 Use case 23: Add machine, production cell or production line	29
70	2.6.5 Use case 26: Machine cloning	30
71	2.7 Further Industrial Automation Use Cases.....	31
72	2.7.1 Use case 30: Security	31
73	Abbreviations	33
74	Literature and related Contributions	33
75		
76		
77		
78		
79		

80 **Figures**

81	Figure 1 – Hierarchical structure of industrial automation	8
82	Figure 2 – Principle of interoperation	10
83	Figure 3 – Scope of work	10
84	Figure 4 – Different Types of Domains.....	11
85	Figure 5 – Three TSN domains connected by Bridges	12
86	Figure 6 – Three TSN domains connected by Routers.....	13
87	Figure 7 – Gateways with two TSN domains and an attached Fieldbus	14
88	Figure 8 – plant wide time synchronization	15
89	Figure 9 – line/cell/machine wide working clock synchronization overlapping with a universal time	
90	domain.....	15
91	Figure 10 – Bidirectional Communication.....	20
92	Figure 11 – Principle data flow of control loop.....	21
93	Figure 30 – ring topology	22
94	Figure 31 – connection of rings	22
95	Figure 33 – HMI wireless connected using cyclic real-time	23
96	Figure 34 – Remote IO wireless connected using cyclic real-time.....	23
97	Figure 35 – Ring segment wireless connected for media redundancy.....	23
98	Figure 51 – M2M/C2C between TSN domains	25
99	Figure 52 – M2M with supervisory PLC.....	26
100	Figure 53 – M2M with four machines	26
101	Figure 54 – M2M with diagnostics/monitoring PC	27
102	Figure 55 – pass-through one machine.....	28
103	Figure 56 – pass-through one machine and production cell	28
104	Figure 57 – pass-through two machines	28
105	Figure 58 – machine with diagnostics / monitoring PC	28
106	Figure 62 – AGV plug and unplug	29
107	Figure 64 – add machine	30
108	Figure 67 – Machine internal communication with isolated logical infrastructure	31

109

110

111

112

113 **Tables**

114	Table 1 – Industrial automation traffic types summary	17
115	Table 2 – isochronous cyclic real-time and cyclic real-time traffic type properties	18
116	Table 3 – Application types	21

117 1 Terms and Definitions

118 1.1 Definitions

Reconfiguration	<ul style="list-style-type: none"> - Any intentional modification of the system structure or of the device-level content, including updates of any type - Ref: IEC 61158- Type 10, dynamic reconfiguration - Document provided by PI/PNO: Guidelines for high-availability
(Process) disturbance	<ul style="list-style-type: none"> - Any malfunction or stall of a process/machine, which is followed by production loss or by an unacceptable degradation of production quality - Ref: IEC 61158 – Failure - Ref. ODVA: Unplanned downtime - Document provided by PI/PNO: Guidelines for diagnosis
Operational state of a plant (unit)/machine	Normal state of function and production of a plant(unit)/machine
Maintenance state of a plant (unit)/machine	Planned suspension or partial suspension of the normal state of function of a plant(unit)/machine
Stopped state of a plant (unit)/machine	Full non-productive mode of a plant(unit)/machine
Convergent network concept	All LAN devices (wired or wireless) are able to exchange data over a common infrastructure, within defined QoS parameters
Device	End station, bridged end station, bridge, access point
DCS	Distributed Control System
Transmission selection algorithms	A set of algorithms for traffic selection which include Strict Priority, the Credit-based shaper and Enhanced Transmission Selection. ¹⁾
Preemption	The suspension of the transmission of a preemptable frame to allow one or more express frames to be transmitted before transmission of the preemptable frame is resumed. ¹⁾
Enhancements for scheduled traffic	A Bridge or end station may support enhancements that allow transmission from each queue to be scheduled relative to a known timescale. ¹⁾
Time-Sensitive Stream	A stream of traffic, transmitted from a single source station, destined for one or more destination stations, where the traffic is sensitive to timely delivery, and in particular, requires transmission latency to be bounded. ¹⁾
TSN domain	A quantity of commonly managed industrial automation devices; A set of devices, their Ports, and the attached individual LANs that transmit Time-Sensitive Streams using TSN standards which include Transmission Selection Algorithms, Preemption, Time Synchronization and Enhancements for Scheduled Traffic and that share a common management mechanism.

¹ taken from 802.1Q-2018

	It is an administrative decision to group these devices (see 2.2).
universal time domain	gPTP domain used for the synchronization of universal time
working clock domain	gPTP domain used for the synchronization of a working clock
isochronous domain	stations of a common working clock domain with a common setup for the isochronous cyclic real-time traffic type
cyclic real-time domain	stations with a common setup for the cyclic real-time traffic type - even from different working clock domains or synchronized to a local timescale
Network cycle	transfer time including safety margin, and application time including safety margin (see Error! Reference source not found.); values are specific to a TSN domain and specify a repetitive behavior of the network interfaces belonging to that TSN domain;
Greenfield	for the context of this document: greenfield refers to TSN-IA profile conformant devices; regardless if "old" or "new";
Brownfield	for the context of this document: brownfield refers to devices, which are not conformant to the TSN-IA profile; regardless if "old" or "new";
Stream forwarding	Forwarding of stream data along the stream path including TSN domain boundary crossings

119 1.2 IEEE802 terms

Priority regeneration	See IEEE 802.1Q-2018 clause 6.9.4 Regenerating priority
Ingress rate limiting	See IEEE 802.1Q-2018 clause 8.6.5 Flow classification and metering

120

121
122

2 TSN in Industrial Automation

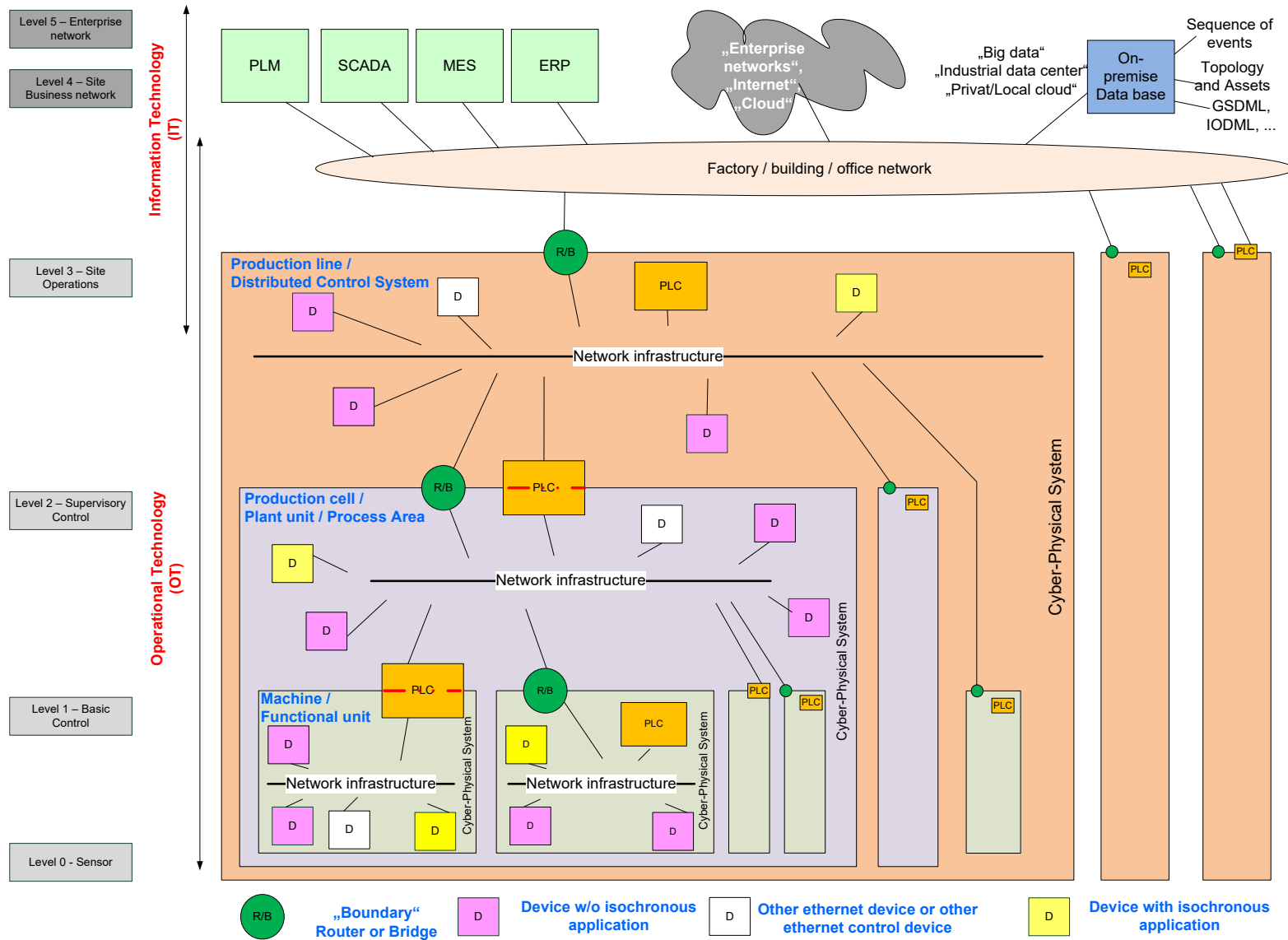

123

124
125

Figure 1 – Hierarchical structure of industrial automation

126 There is no generally accepted definition of the term “Cyber-Physical System (CPS)”. A report of
127 Edward A. Lee [1] suitably introduces CPS as follows: „*Cyber-Physical Systems (CPS) are*
128 *integrations of computation with physical processes. Embedded computers and networks monitor*
129 *and control the physical processes, usually with feedback loops where physical processes affect*
130 *computations and vice versa.*”
131

132 Cyber-Physical Systems are the building blocks of “smart factories” and Industry 4.0. IEEE 802
133 LAN technologies provide the mechanisms (e.g. TSN features) for connectivity to time critical
134 industrial applications on converged networks in operational technology control levels.
135

136 IEEE 802 LANs with TSN features can be used in Industrial Automation for:

- 137 • Real-time (RT) Communication within Cyber-Physical Systems
- 138 • Real-time (RT) Communication between Cyber-Physical Systems

139 A CPS consists of:

- 141 ○ Controlling devices (typically 1 PLC),
- 142 ○ I/O Devices (sensors, actors),
- 143 ○ Drives,
- 144 ○ HMI (typically 1),
- 145 ○ Interface to the upper level with:
 - 146 - PLC (acting as gateway), and/or
 - 147 - Router, and/or
 - 148 - Bridge.
- 149 ○ Other Ethernet devices:
 - 150 - Servers or any other computers, be it physical or virtualized,
 - 151 - Diagnostic equipment,
 - 152 - Network connectivity equipment.

153 2.1 Interoperability

154 Interoperability may be achieved on different levels. Figure 2 and Figure 3 show three areas, which
155 need to be covered:

- 156 - network configuration (managed objects according to IEEE definitions), and
- 157 - stream configuration and establishment, and
- 158 - application configuration.

159 The three areas mutually affect each other (see Figure 2).

160 Application configuration is not expected to be part of the profile, but the two other areas are.

161 The selection made by the TSN-IA profile covers IEEE 802 defined layer 2 and the selected
162 protocols to configure layer 2.

163 Applications make use of upper layers as well, but these are out of scope for the profile.

164 Stream establishment is initiated by applications to allow data exchange between applications. The
165 applications are the source of requirements, which shall be fulfilled by network configuration and
166 stream configuration and establishment.

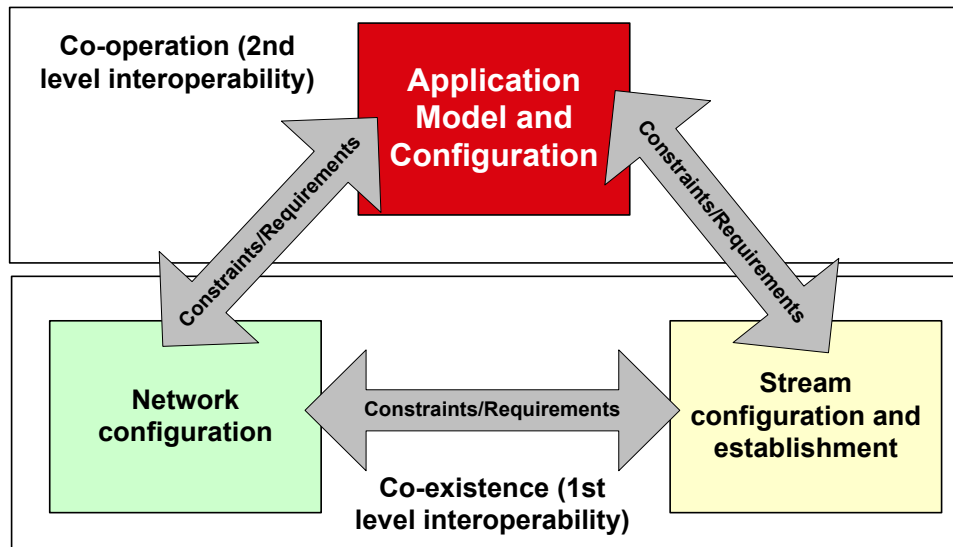

Figure 2 – Principle of interoperation

168
169
170

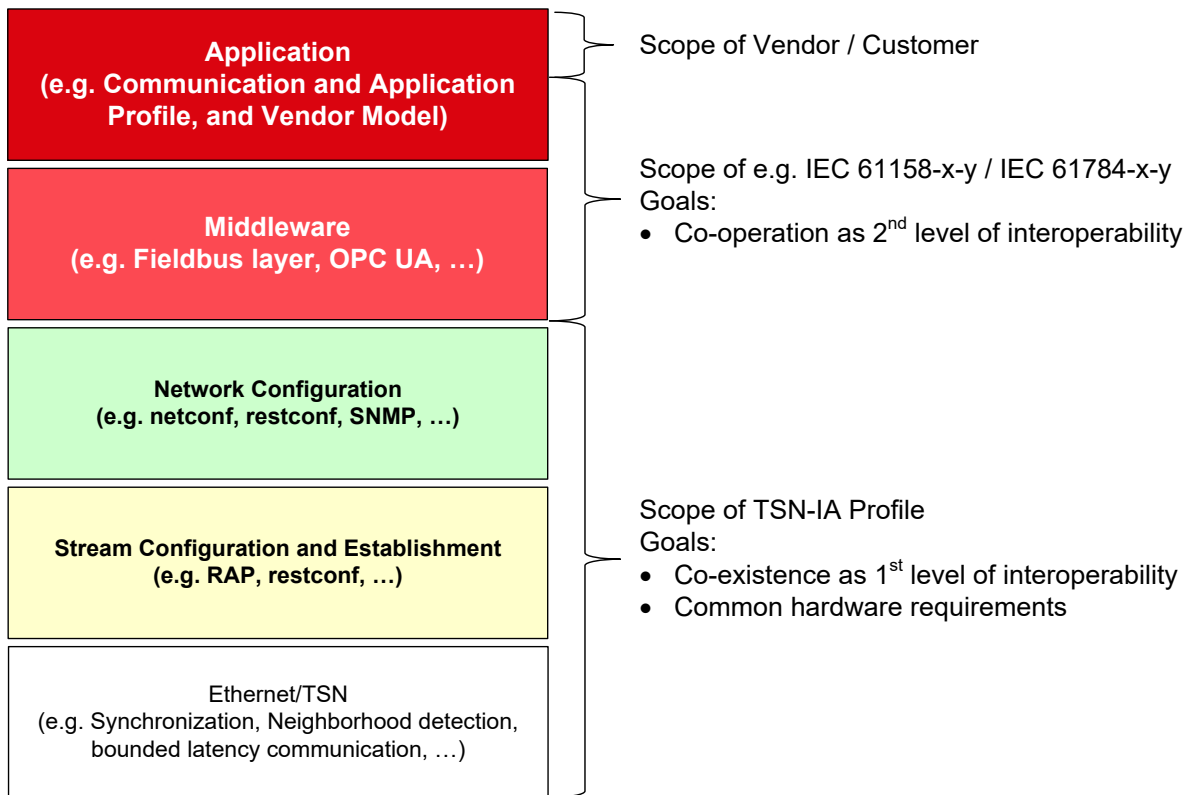

Figure 3 – Scope of work

171
172
173

174 2.2 TSN Domain

175 2.2.1 General

176 A TSN domain is defined as a quantity of commonly managed industrial automation devices; it is
177 an administrative decision to group these devices.

178 TSN Domain Characteristics:

- 179 • One or more TSN Domains may exist within a single layer 2 broadcast domain.
- 180 • A TSN Domain may not be shared among multiple layer 2 broadcast domains.
- 181 • Multiple TSN Domains may share a common universal time domain.
- 182 • Two adjacent TSN Domains may implement the same requirements but stay separate.
- 183 • Multiple TSN domains will often be implemented in one bridge (see 2.2.2.2).
- 184 • Multiple TSN domains will often be implemented in one router (see 2.2.2.3).
- 185 • Multiple TSN domains will often be implemented in one gateway (see 2.2.2.4).

186 Typically machines/functional units (see Figure 1) constitute separate TSN domains. Production
 187 cells and lines may be set up as TSN domains as well. Devices may be members of multiple TSN
 188 domains in parallel.

189 Figure 4 shows two example TSN domains within a common broadcast domain and a common
 190 universal time domain. TSN domain 1 is a pure cyclic real-time domain, whereas TSN domain 2
 191 additionally includes three overlapping isochronous domains.
 192

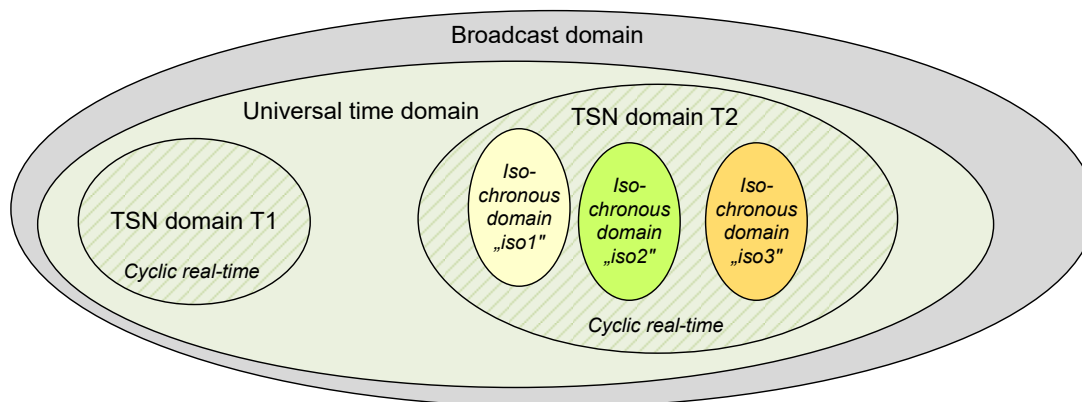

193

194 **Figure 4 – Different Types of Domains**

195 Interconnections between TSN domains are described in 2.2.2 and 2.6.1.

196 **2.2.2 Interconnection of TSN Domains**

197 **2.2.2.1 General**

198 TSN domains may be connected via

- 199 - Bridges (Layer 2), or
- 200 - Routers (Layer 3), or
- 201 - Application Gateways (Layer 7).

202 Wireless Access Points or 5G Base Stations may be used to connect TSN domains, too.

203 **2.2.2.2 Bridges (Layer 2)**

204 When a Bridge is member of multiple TSN domains, one bridge port must only be a member of a
 205 single TSN domain.

206 Figure 5 provides an example of two Bridges, which are members of two TSN domains each.
 207 Bridge B1 provides ports and connectivity in TSN domain Production Cell 1 and in TSN domain
 208 Machine 1, Bridge B2 for Production Line 1 and Production Cell 1.

209

210
211

Figure 5 – Three TSN domains connected by Bridges

212 To support connectivity between multiple TSN domains (e.g. PLC L1 ↔ PLC M1) a method for
 213 reserving time-sensitive streams over multiple TSN domains needs to be specified, including:

- 214 - find the communication partner,
 215 - identify the involved TSN domains,
 216 - identify the involved management entities independent from the configuration model
 217 (centralized, hybrid, fully distributed),
 218 - ensure the needed resources,
 219 - parameterize the TSN domain connection points to allow stream forwarding if needed.

220 **2.2.2.3 Routers (Layer3)**

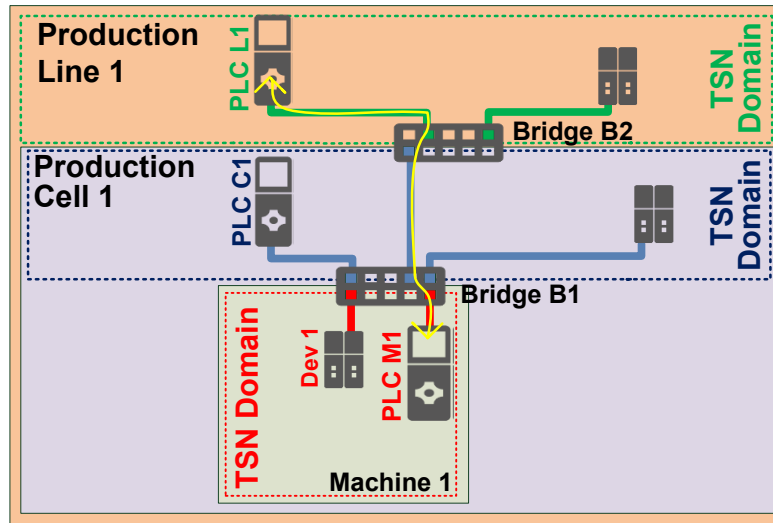
221 Together with routers, both intranet and internet are possible. In this sub-clause, however, only the
 222 intranet use case is addressed.

223 When a router is member of multiple TSN domains, one router interface/port must only be a
 224 member of a single TSN domain. Figure 6 provides an example of two routers, which are members
 225 of two TSN domains each. Router R1 provides ports and connectivity in TSN domain Production
 226 Cell 1 and in TSN domain Machine 1, Router R2 for Production Line 1 and Production Cell 1.

227

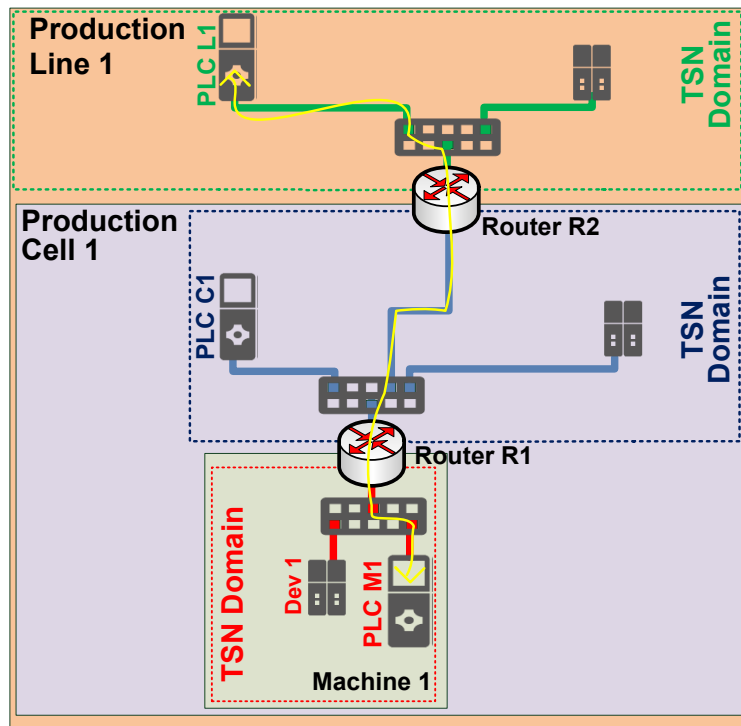

228

229 **Figure 6 – Three TSN domains connected by Routers**

230 To support connectivity between multiple TSN domains (e.g. PLC L1 ↔ PLC M1) a method for
 231 reserving time-sensitive streams over multiple TSN domains needs to be specified, including:

- 232
- 233 - find the communication partner,
 - 234 - identify the involved TSN domains,
 - 235 - identify the involved management entities independent from the configuration model
(centralized, hybrid, fully distributed),
 - 236 - ensure the needed resources,
 - 237 - parameterize the TSN domain connection points to allow stream forwarding if needed.

238 2.2.2.4 Application Gateways (Layer7)

239 When an Application Gateway is member of multiple TSN domains, one gateway interface/port
240 must only be a member of a single TSN domain.

241 Figure 7 provides an example of two application gateways:

- 242 - Gateway CM1 is member in the TSN domains Production Cell 1 and Machine 1;
- 243 - Gateway CF1 is member of the TSN domain Production Cell 1 and of Fieldbus 1.

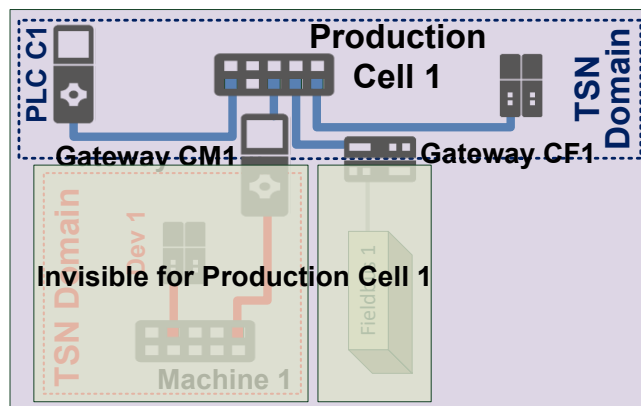

244
245

Figure 7 – Gateways with two TSN domains and an attached Fieldbus

246 Application level gateways do not provide direct access between devices of different TSN domains.
247 Instead the application gateways act as end-stations for TSN domain egress and ingress
248 communication.

249 An application specific translation of control and data to access adjacent TSN domains may be
250 implemented in the application level gateway to realize TSN domain interconnections. The
251 translation may even involve buffering, collecting and re-arranging of data and control. Thereby
252 application level gateways decouple TSN domains, so that the internal structure and configuration
253 of adjacent TSN domains is not visible respectively.

254 Application level gateways are also used to connect non-Ethernet- or Ethernet-based fieldbuses to
255 TSN domains (see Gateway CF1 in Figure 7 and see also **Error! Reference source not found.**).

256

257 2.3 Synchronization

258 2.3.1 General

259 Synchronization covering both universal time (wall clock) and working clock is needed for industrial
260 automation systems.

261 Redundancy for synchronization of universal time may be solved with “cold standby”. Support of
262 “Hot standby” for universal time synchronization is not current practice - but may optionally be
263 supported depending on the application requirements.

264 Redundancy for working Clock synchronization can be solved with “cold standby” or “hot standby”
265 depending on the application requirements. Support of “hot standby” for working clock
266 synchronization is current practice.

267 More details about redundancy switchover scenarios are provided in:

268 <http://www.ieee802.org/1/files/public/docs2018/60802-Steindl-TimelinessUseCases-0718-v01.pdf>.

269 2.3.2 Universal Time Synchronization

270 Universal time is used to plant wide align events and actions (e.g. for “sequence of events”). The
 271 assigned timescale is TAI, which can be converted into local date and time if necessary. Figure 8
 272 shows the principle structure of time synchronization with the goal to establish a worldwide aligned
 273 timescale for time. Thus, often satellites are used as source of the time.

274

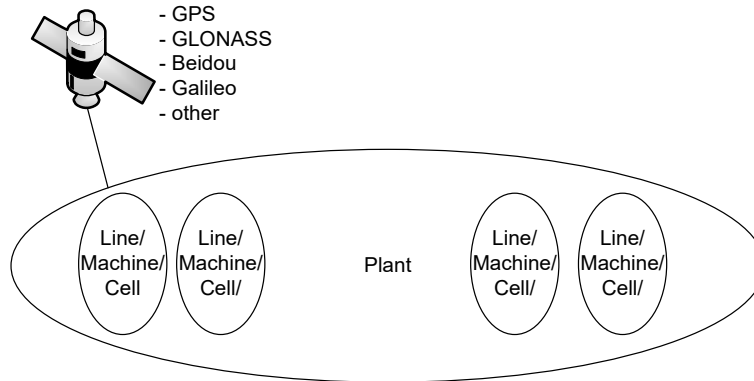

275

276 **Figure 8 – plant wide time synchronization**

277 Note: “Global Time” or “Wall Clock” are often used as synonym terms for “Universal Time”.

278 2.3.3 Working Clock Synchronization

279 Working Clock is used to align actions line, cell or machine wide. The assigned timescale is
 280 arbitrary. Robots, motion control, numeric control and any kind of clocked / isochronous application
 281 rely on this timescale to make sure that actions are precisely interwoven as needed. Figure 9
 282 shows the principle structure of Working Clock synchronization with the goal to establish a line /
 283 cell / machine wide aligned timescale. Thus, often PLCs, Motion Controller or Numeric Controller
 284 are used as Working Clock source.

285 If multiple PLCs, Motion Controller or Numeric Controller need to share one Working Clock
 286 timescale (e.g. for scheduled traffic), an all-time active station shall be used as Working Clock
 287 source, also known as Grandmaster.

288

289 **Figure 9 – line/cell/machine wide working clock synchronization overlapping with a**
 290 **universal time domain**

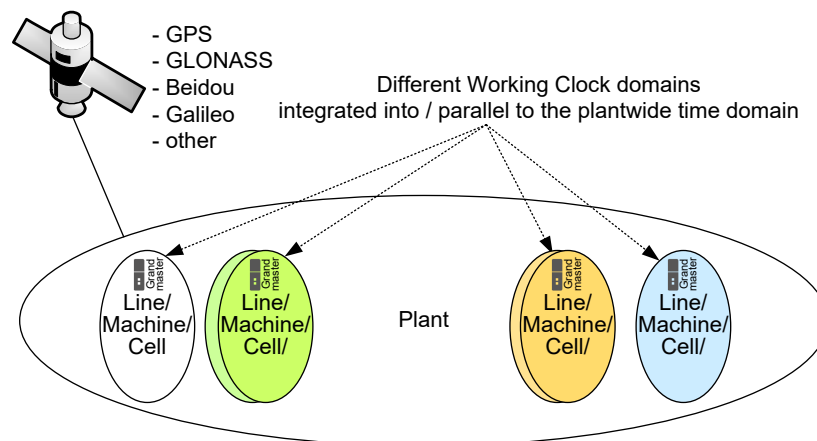

288

289 **Figure 9 – line/cell/machine wide working clock synchronization overlapping with a**
 290 **universal time domain**

291 Working Clock domains may be doubled to support zero failover time for synchronization.

292 High precision working clock synchronization is a prerequisite for control loop implementations with
293 low latency (see 2.4.2).

294

295 Requirements:

- 296 • High precision working clock synchronization;
- 297 • Maximum deviation to the grandmaster time in the range from 100 ns to 1 μ s;
- 298 • Support of redundant sync masters and domains;
- 299 • Zero failover time in case of redundant working clock domains;

300

301 Useful 802.1 mechanisms:

- 302 • IEEE 802.1AS-Rev

303

304 2.4 Industrial automation modes of operation

305 2.4.1 Industrial automation traffic types

306 **Note: is this still necessary in the Use Cases document? Has the material in 60802**
307 **superseded it?**

308 2.4.1.1 General

309 Industrial automation applications concurrently make use of different traffic types for different
310 functionalities, e.g. parameterization, control, alarming. The various traffic types have different
311 characteristics and thus impose different requirements on a TSN network. This applies for all use
312 cases described in this document.

313 Table 1 subsumes the industrial automation relevant traffic patterns to traffic types with their
314 associated properties (see also [4]).

Table 1 – Industrial automation traffic types summary

Traffic type name	Periodic/ Sporadic	Guarantee	Data size	Redundancy	Details
isochronous cyclic real-time	P	deadline/ bounded latency (e.g. 20%@1 Gbit/s / 50%@100 Mbit/s network cycle)/ bandwidth	bounded	up to seamless ¹⁾	see Error! Reference source not found. and 2.4.2
cyclic real-time	P	deadline/ bounded latency (e.g. n-times network cycle)/ bandwidth	bounded	up to seamless ¹⁾	see Error! Reference source not found. and Error! Reference source not found.
network control	S	Priority	-	up to seamless ¹⁾ as required	see 2.2.2 and 2.5.1
audio/video	P	bounded latency/ bandwidth	bounded	up to seamless ¹⁾ as required	-
brownfield	P	bounded latency/ bandwidth	-	up to regular ²⁾	see Error! Reference source not found.
alarms/ events	S	bounded latency/ bandwidth	-	up to regular ²⁾	see Error! Reference source not found.
configuration/ diagnostics	S	Bandwidth	-	up to regular ²⁾	see Error! Reference source not found.
Internal / Pass-through	S	Bandwidth	-	up to regular ²⁾	see 2.6.2
best effort	S	-	-	up to regular ²⁾	-

316

317

¹⁾ almost zero failover time;

318

319

²⁾ larger failover time because of network re-convergence

320

321

All traffic types of Table 1 are referenced by the use cases, which are described in this document:

322

323

Isochronous:

324

→ see **Error! Reference source not found.**

325 In addition, if an isochronous application interface is needed: Machine vision application use cases
 326 for counting, sorting, quality control, video surveillance, augmented reality, motion guidance ...

327
 328 Cyclic:

329 → see **Error! Reference source not found.**

330 In addition, if a cyclic application interface is needed: Machine vision application use cases for
 331 counting, sorting, quality control, video surveillance, augmented reality, motion guidance ...

332
 333 Network control:

334 → see *Use case 01: Redundant networks*

335
 336 Audio/video:

337 → IEEE Std 802.1BA-2011 (AVB) may be supported in industrial automation as well

338
 339 Brownfield:

340 → see **Error! Reference source not found.**

341
 342 Alarms/events:

343 → see **Error! Reference source not found.**

344
 345 Configuration/diagnostics:

346 → see **Error! Reference source not found.**

347
 348 Internal:

349 → see *Use case 04: Pass-through Traffic*

350 Best effort:

351 → see ...

352 **2.4.1.2 Characterization of isochronous cyclic real-time and cyclic real-time**

353 The following properties table is used to characterize in detail the traffic types of **Error! Reference**
 354 **source not found.** and **Error! Reference source not found..**

355 **Table 2 – isochronous cyclic real-time and cyclic real-time traffic type properties**

Property	Description
Data transmission scheme	<i>Periodic (P)</i> - e.g. every $N \mu\text{s}$, or <i>Sporadic (S)</i> - e.g. event-driven
Data transmission constraints	<p>Indicates the traffic pattern's data transmission constraints for proper operation. Four data transmission constraints are defined:</p> <ul style="list-style-type: none"> • <i>deadline</i>: transmitted data is guaranteed to be received at the destination(s) before a specific instant of time, • <i>latency</i>: transmitted data is guaranteed to be received at the destination(s) within a specific period of time after the data is transmitted by the sending application, • <i>bandwidth</i>: transmitted data is guaranteed to be received at the destination(s) if the bandwidth usage is within the resources reserved by the transmitting applications,

Property	Description
	<ul style="list-style-type: none"> <i>none</i>: no special data transmission constraint is given.
Data period	<p>For traffic types that transmit <i>periodic</i> data this property denotes according to the <i>data transmission constraints</i>:</p> <p><i>deadline</i>: application data deadline period, <i>latency, bandwidth or none</i>: data transmission period.</p> <p>The period is given as a <i>range</i> of time values, e.g. 1μs ... 1ms. For the <i>sporadic</i> traffic types, this property does not apply.</p>
Network access (data transmission) synchronized to working clock (network cycle)	<p>Indicates whether the data transmission of sender stations is synchronized to the working clock (network cycle).</p> <p>Available property options are: <i>yes, no or optional</i>.</p>
Application synchronized to network access	<p>Indicates whether the applications, which make use of this traffic pattern, are synchronized to the network access.</p> <p>Available property options are: <i>yes or no</i>.</p>
Acceptable jitter	<p>Indicates for traffic types, which apply data transmission with <i>latency</i> constraints, the amount of jitter, which can occur and must be coped with by the receiving destination(s).</p> <p>For traffic types with <i>deadline, bandwidth or none</i> data transmission constraints this property is not applicable (<i>n.a.</i>).</p>
Acceptable frame loss	<p>Indicates the traffic pattern's tolerance to lost frames given e.g. as acceptable frame loss ratio range.</p> <p>The frame loss ratio value <i>0</i> indicates traffic types, where no single frame loss is acceptable.</p>
Payload	<p>Indicates the payload data <i>type</i> and <i>size</i> to be transmitted. Two payload types are defined:</p> <ul style="list-style-type: none"> <i>fixed</i>: the payload is always transmitted with exactly the same size <i>bounded</i>: the payload is always transmitted with a size, which does not exceed a given maximum; the maximum may be the maximum Ethernet payload size (1500).

356 2.4.2 Bidirectional communication relations

357 The general behavior of field devices of process sensors and output signals is preconfigured and
358 offers a set of services to a machine control unit. More complex field devices such as drives or
359 machine parts have process data in both directions. If there are only outputs in a field device the
360 stream back to the machine control is necessary for fast detection of problems in a field device. If
361 there are only input process data the stream from the machine control to the field device is not
362 necessary for normal operation.

363 The cell control communicates with the machine controls of the machines also in a bidirectional
364 way.

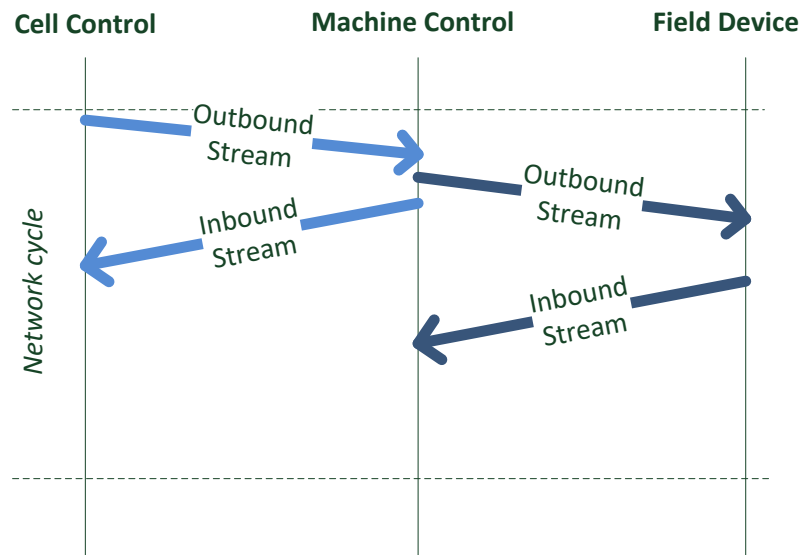

365

366 **Figure 10 – Bidirectional Communication**

367 Requirements:

- 368
- 369
- Support of bidirectional streams;
 - Sequence of actions how to establish such streams (see Figure 10);

370 Useful 802.1 mechanisms:

- 371
- IEEE 802.1Q (usage of streams)

372 **2.4.3 Control Loop Basic Model**

373 **Control loops** are fundamental building blocks of industrial automation systems. Control loops include:
 374 process sensors, a controller function, and output signals. Control loops may require guaranteed low
 375 latency or more relaxed bounded latency (see **Error! Reference source not found.**) network transfer
 376 quality.

377 To achieve the needed quality for Control loops the roundtrip delay (sometimes called makespan,
 378 too) of the exchanged data is essential.

379 Figure 11 shows the whole transmission path from Controller application to Device application(s)
 380 and back. The blue and red arrows show the contributions to the e2e (end-to-end) latency
 381 respectively.

382

383 Figure 11 and Table 3 show three levels of a control loop:

- 384
- 385
- 386
- Application - within Talker/Listener,
 - Network Access - within Talker/Listener,
 - Network Forwarding - within Bridges.

387 Network Access is always synchronized to a common working clock or to a local timescale.

388 Application may or may not be synchronized to the synchronized Network Access depending on
 389 the application requirements. Applications which are synchronized to Network Access are called
 390 “isochronous applications”. Applications which are not synchronized to Network Access are called
 391 “non-isochronous applications”.

392 Network Forwarding may or may not be synchronized to a working clock depending on whether the
 393 Enhancements for Scheduled Traffic (IEEE Std 802.1Q-2018) are applied.

394

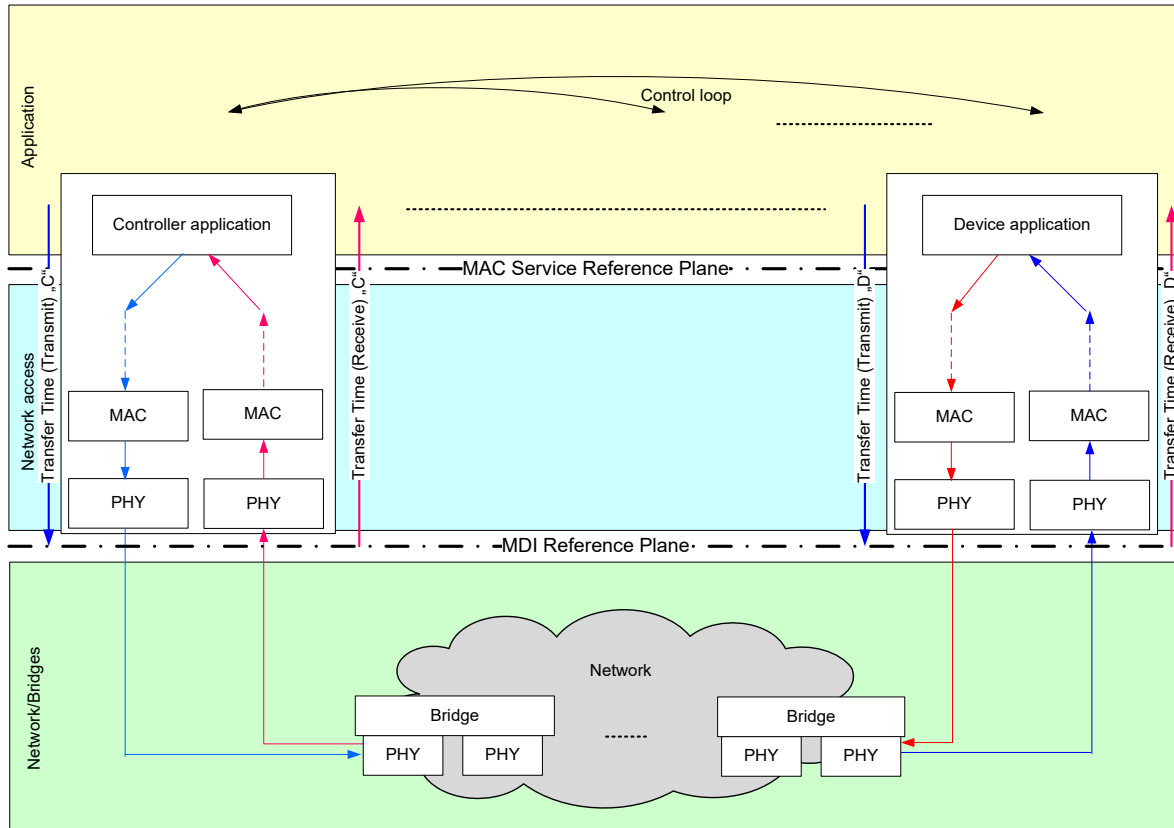

395
396

Figure 11 – Principle data flow of control loop

397 Transfer Times contain PHY and MAC delays. Both delays are asymmetric and vendor specific.
398 Device vendors have to take into account these transfer times when their application cycle models
399 are designed (see Figure 11 and **Error! Reference source not found.**).
400

401

Table 3 – Application types

Level	Isochronous Application		Non-isochronous Application		
Application	Synchronized to network access		Synchronized to local timescale		
Network access	Synchronized to working clock, Stream Class based scheduling, Preemption				Synchronized to local timescale, Stream Class based scheduling, Preemption
Network/Bridges	Synchronized to working clock	Free running	Synchronized to working clock	Free running	Free running
	Scheduled traffic + Strict Priority + Preemption	Strict Priority or other Shaper + Preemption	Scheduled traffic + Strict Priority + Preemption	Strict Priority or other Shaper + Preemption	Strict Priority or other Shaper + Preemption

402

403 2.5 Industrial automation networks

404 2.5.1 Use case 01: Redundant networks

405 Ring topologies are the basic industrial network architecture for switch-over or seamless
406 redundancy.

407

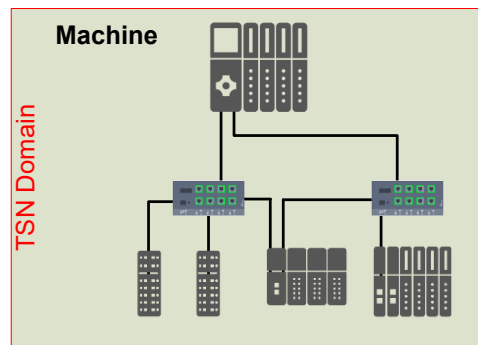

408

Figure 12 – ring topology

409 When a production cell is also arranged in a ring topology the resulting architecture of cell with
410 attached machines is an interconnection of rings.

411 To even improve availability of the interconnection from the production cell into the machines this
412 link can be arranged redundantly as well (machine 1 in Figure 13):

413

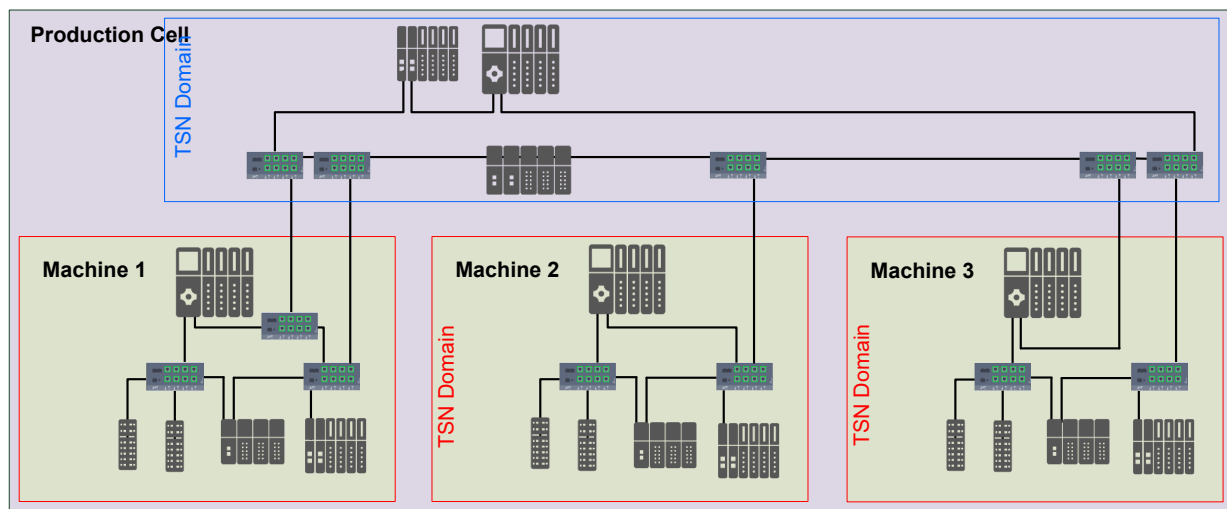

414

Figure 13 – connection of rings

415 Requirement:

416 Support redundant topologies with rings.

417

418 **Note: FRER is part of 60802, but not all features. (End Station replication & elimination**
419 **supported; but not for Relays.)**

420

421 Useful 802.1 mechanisms:

- 422 • 802.1CB - FRER

423

424 **2.5.2 Use case 02: Wireless**

425 HMI panels, remote I/Os, wireless sensors or wireless bridges are often used in industrial
 426 machines. Wireless connections may be based on IEEE 802.11 (Wi-Fi), IEEE 802.15.1 (Bluetooth),
 427 IEEE 802.15.4 or ITU/3GPP (5G). Even functional safety applications over wireless connections
 428 are supported (see **Error! Reference source not found.**).

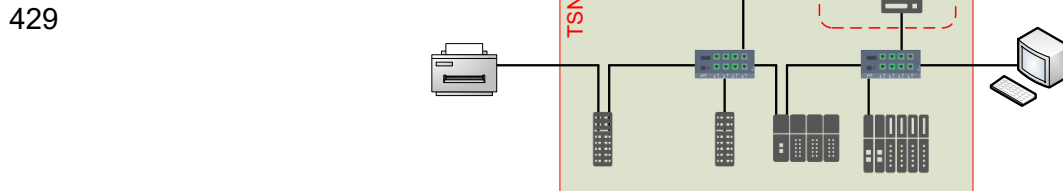

430 **Figure 14 – HMI wireless connected using cyclic real-time**

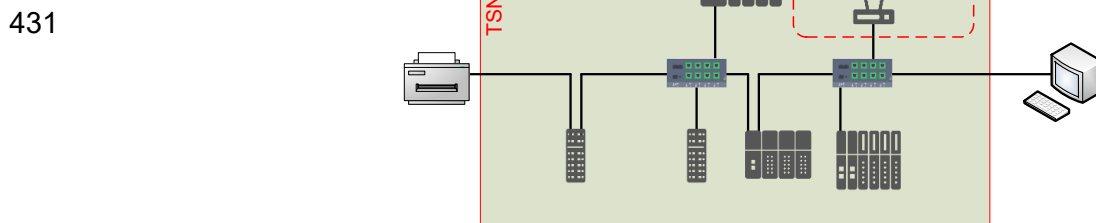

432 **Figure 15 – Remote IO wireless connected using cyclic real-time**

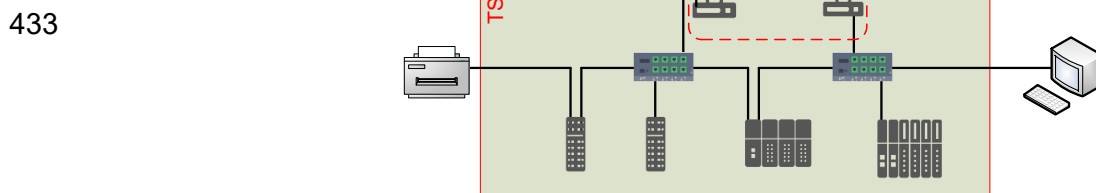

434 **Figure 16 – Ring segment wireless connected for media redundancy**

435 **Requirement:**
 436

- 437 Support of wireless for
- 438 • cyclic real-time, and
 - 439 • non-real-time communication

440 **Useful 802.11 mechanisms:**
 441

- 442 • Synchronization support

- 443 • Extensions from .11ax
444 • ...
445

446 Useful 802.15.1 mechanisms:

- 447 • ...
448

449 Useful 802.1Q mechanisms:

- 450 • ...
451

452 limits and cycle times (see e.g. row Data period in **Error! Reference source not found.**).
453

454 **2.5.3 Use case N10: Multi-Subnet Operation**

455 See [4].

456

457

2.6 Industrial automation machines, production cells, production lines

458

2.6.1 Use case 03: Machine to Machine/Controller to Controller (M2M/C2C) Communication

459

Preconfigured machines with their own TSN domains, which include tested and approved internal communication, communicate with other preconfigured machines with their own TSN domains, with a supervisory PLC of the production cell (with its own TSN domain) or line (with its own TSN domain) or with an Operations Control HMI (with its own TSN domain).

460

461

462

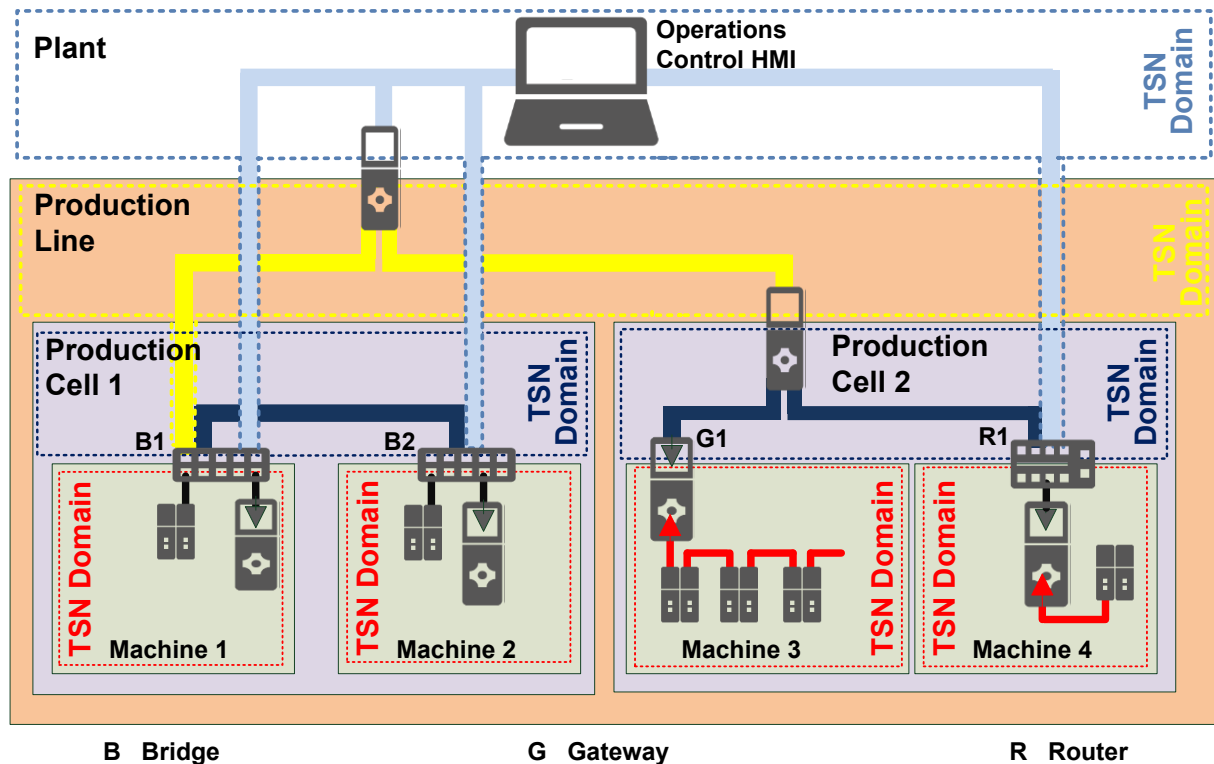

463

464

Figure 17 – M2M/C2C between TSN domains

465

Figure 17 shows that multiple logical overlapping TSN Domains arise, when controllers use a single interface for the M2M communication with controllers of the cell, line, plant or other machines. Decoupling of the machine internal TSN Domain can be accomplished by applying a separate controller interface for M2M communication.

467

468

469

Machine 1: the controller link to its connected cell bridge B1 is concurrently member of the TSN Domains of Machine 1, Production Cell 1, Production Line and Plant.

470

471

Machine 2: the controller link to its connected cell bridge B2 is concurrently member of the TSN Domains of Machine 2, Production Cell 1 and Plant.

472

473

Machine 3: the controller is directly attached to the PLC of Production Cell 2 and is therefore member of the TSN Domain of Production Cell 2. The machine internal TSN Domain is decoupled from M2M traffic by a separate interface.

474

475

476

Machine 4: the controller link to its connected cell bridge B3 is concurrently member of the TSN Domains of Production Cell 2 and Plant. The machine internal TSN Domain is decoupled from M2M traffic by a separate interface.

477

478

479

480

Examples:

481

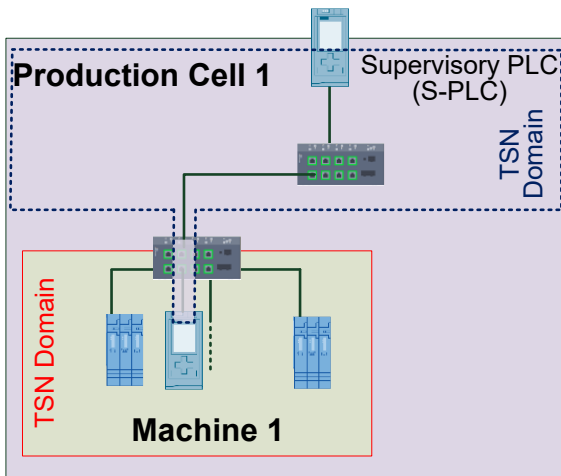

Figure 18 – M2M with supervisory PLC

There are quite a few constraints related to the machine internal networks. Each machine may run a different schedule and even the intervals may be different. It may be very complex or even impossible to find an optimal communication schedule down from the sensors and actuators to the cell control. The requirements for cascaded control loops require faster intervals for the lower control loops. The multiple machine intervals embedded in one cell interval can be mapped onto a sequence of intervals. Each step in the exchange of data between machine and cell control unit can be mapped into machine intervals:

- outbound cell communication,
- transfer outbound within machine network,
- transfer inbound within machine network,
- inbound cell communication.

Additionally Figure 20 shows an example where M2M communication is used to connect a PC for diagnostics/monitoring.

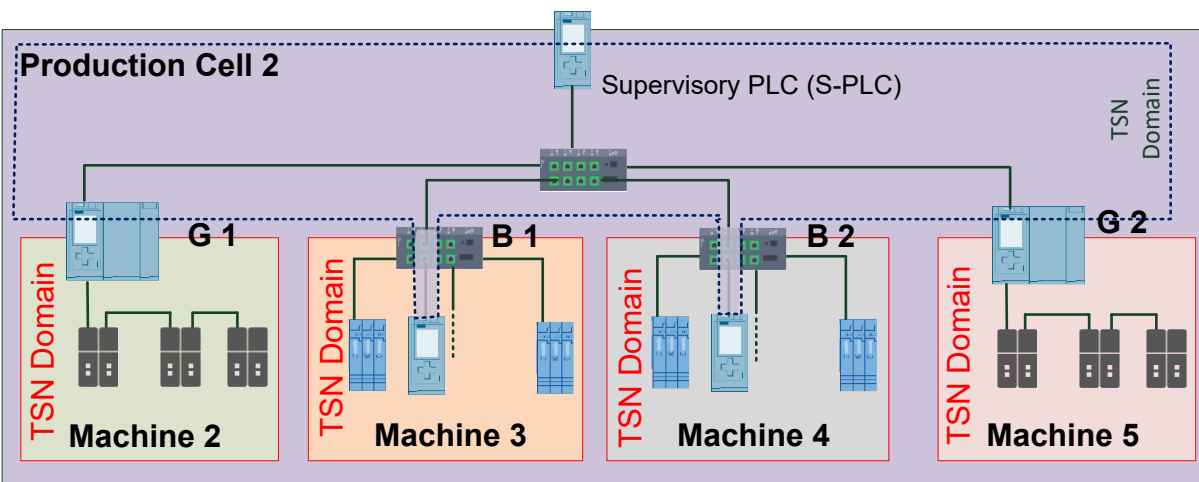

Figure 19 – M2M with four machines

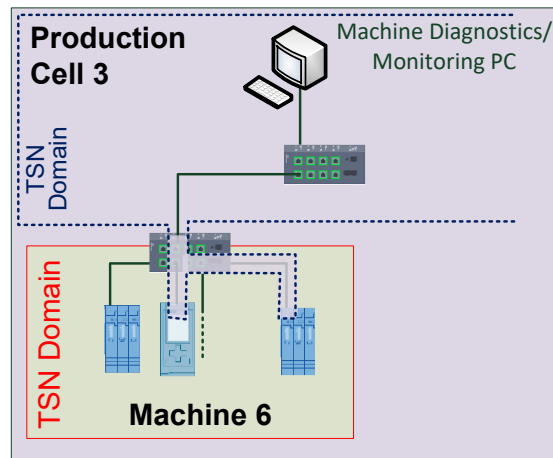

Figure 20 – M2M with diagnostics/monitoring PC

482 Figure 20 shows a M2M diagnostics related use case: communication is cyclic and shall happen
 483 within short application cycle times. An example of this use case is the verification of proper
 484 behavior of a follower drive, in a master-follower application. Today, the use case is covered by
 485 connecting a common PC to an interface of the follower drive. The various TSN mechanisms may
 486 now make it possible to connect such a PC network interface card anywhere in the system network
 487 and still gather the same diagnostics with the same guarantees, as the current direct connection.

488 The required guarantees are:

489 Each 4 ms a frame shall be sent from a follower drive and have its delivery guaranteed to the
 490 network interface of the PC used to perform the diagnostics. Of course, local PC-level processing
 491 of such frames has to be implemented such that the diagnostic application gets the required quality
 492 of service.

493 From the communication point of view the two types of machine interface shown in Figure 19 are
 494 identical. The PLC represents the machine interface and uses either a dedicated (machine 1 and 4)
 495 or a shared interface (machine 2 and 3) for communication with other machines and/or a
 496 supervisor PLC.

497 The communication relations between machines may or may not include or make use of a
 498 supervisory PLC.

499 Requirement:

- 500 • All machine internal communication (stream traffic and non-stream traffic) is decoupled from
 501 and protected against the additional M2M traffic and vice versa.
- 502 • 1:1 and 1:many communication relations shall be possible.
- 503 • Scheduling in a way that interleaved operation with machine intervals is possible.

504 Useful 802 mechanisms:

- 505 • IEEE Std 802.1Q-2018, Fixed priority, IEEE Std 802.3br
- 506 • Priority Regeneration,
- 507 • Queue-based resource allocation,
- 508 • VLANs to separate TSN domains.

509 2.6.2 Use case 04: Pass-through Traffic

510 Machines are supplied by machine builders to production cell/line builders in tested and approved
 511 quality. At specific boundary ports standard devices (e.g. barcode reader) can be attached to the
 512 machines. The machines support transport of non-stream traffic through the tested/approved
 513 machine ("pass-through traffic") without influencing the operational behavior of the machine, e.g.

514
515

connection of a printer or barcode reader. Figure 21, Figure 22 and Figure 23 give some examples of pass-through traffic installations in industrial automation.

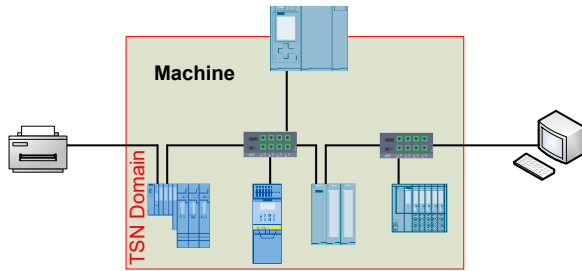

Figure 21 – pass-through one machine

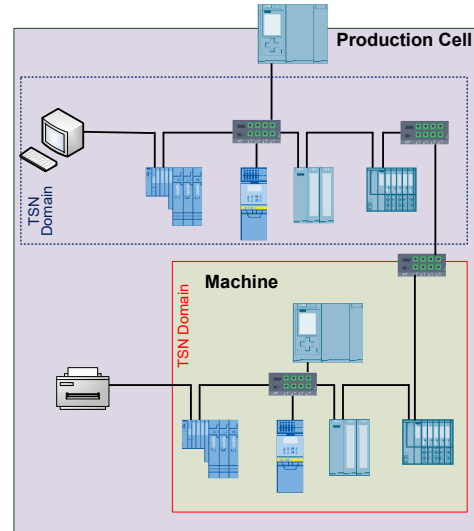

Figure 22 – pass-through one machine and production cell

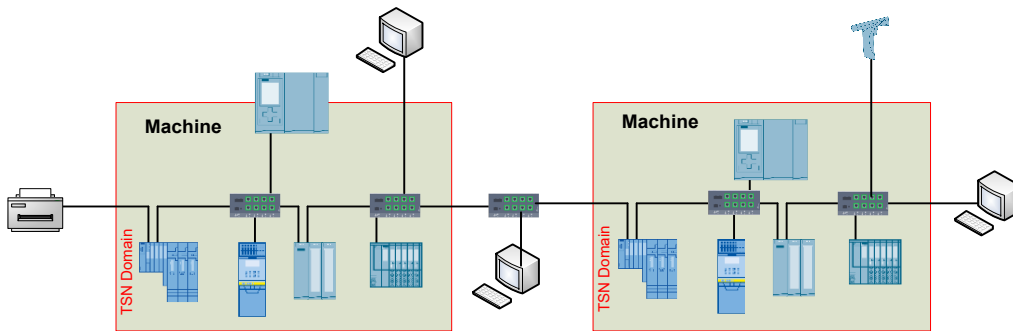

Figure 23 – pass-through two machines

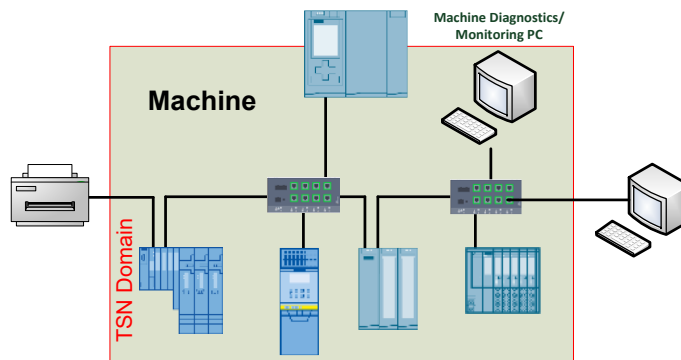

Figure 24 – machine with diagnostics / monitoring PC

516

Requirement:

517 All machine internal communication (stream traffic and non-stream traffic) is decoupled from and
518 protected against the additional “pass-through” traffic.
519 “Pass-through” traffic is treated as separate traffic pattern.

520

521 **Note: Boundary Port prevents pass-through traffic.**

522

523

Useful 802.1Q mechanisms:

- 524
- 525
- 526
- 527
- 528
- Priority Regeneration,
 - separate "pass-through traffic queue",
 - Queue-based resource allocation in all bridges,
 - Ingress rate limiting.

529 **2.6.3 Use case 05: Dynamic plugging and unplugging of machines (subnets)**

530 E.g. multiple AGVs (automatic guided vehicles) access various docking stations to get access to
 531 the supervisory PLC. Thus, an AGV is temporary not available. An AGV may act as CPS or as a
 532 bunch of devices.

533

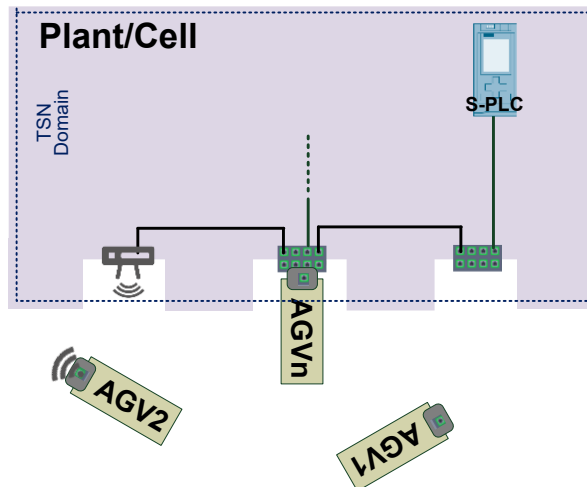

534 **Figure 25 – AGV plug and unplug**

535

536 **Requirement:**

537 The traffic relying on TSN features from/to AGVs is established/removed automatically after
 538 plug/unplug events.

539 Different AGVs may demand different traffic layouts.

540 The time till operate influences the efficiency of the plant.

541 Thousands of AGS may be used concurrently, but only a defined amount of AGVs is connected at
 542 a given time.

543 **Note: Mechanisms to manage wireless connections are missing.**

544

545 **Useful 802.1Q mechanisms:**

- 546
- 547
- 548
- 549
- preconfigured streams
 - ...

550 **2.6.4 Use case 06: Add machine, production cell or production line**

551 When production capacity is exhausted, additional machines, production cells or even production
 552 lines are bought and integrated into a plant.

553 E.g. an additional welding robot is added to a production cell to increase production capacity. The
 554 additional machine has to be integrated into the production cell control with minimal disturbance of
 555 the production cell process.

556

557 Another aspect is when a machine or a group of machines is tested in a stand-alone mode first
 558 before it is used in the combination with other machines or in combination with a supervisory
 559 system.
 560 A flexible cell communication is needed to support this. Enabling and disabling of cell
 561 communication within a machine should be possible with minimal impact on production.

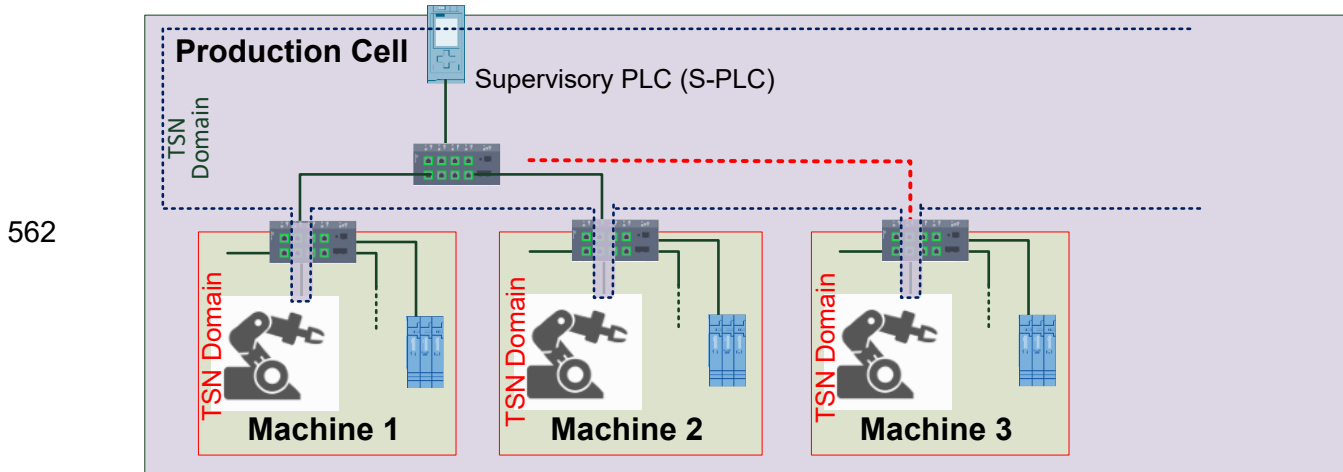

563 **Figure 26 – add machine**

563

564 Requirement:

565 Adding and removing a machine/cell/production line shall not disturb existing installations

566

567 **Note: Only supported within a single configuration domain. Not supported across multiple**
 568 **domains.**

569

570 Useful mechanisms:

- 571 • ...

572

573 2.6.5 Use case 07: Machine cloning

574 The machines used in a cell can be identical but with a different task. Robots are a typical example
 575 of that kind of machines (see Figure 27). Thus, both machines have the same internal
 576 communication flows. The difference is just different machine identification for the external flow.
 577 The concept as of today is that the machine internal configuration has its identification and the cell
 578 system has its configuration but there is no dependency between both. The machine internal setup
 579 is done earlier and the cell identification is a result from a different configuration step and is done
 580 by a different organizational unit. Thus, it is difficult to propagate the cell level identification at the
 581 very beginning to the machine internal components. A worst case scenario is the startup of a
 582 machine and the connection to a cell in an ad hoc way with identification of the machine by the
 583 globally unique MAC address of the machine and the resolution of other addresses within the cell
 584 controller or above (e.g. for allocation of IP addresses). If there is a need to communicate with a
 585 few field device within the machine in a global way the machine subsystem has to be configured
 586 accordingly in advance. This configuration step could be done by a different organization as the
 587 stream configuration and not all machine internal elements may require a global address.

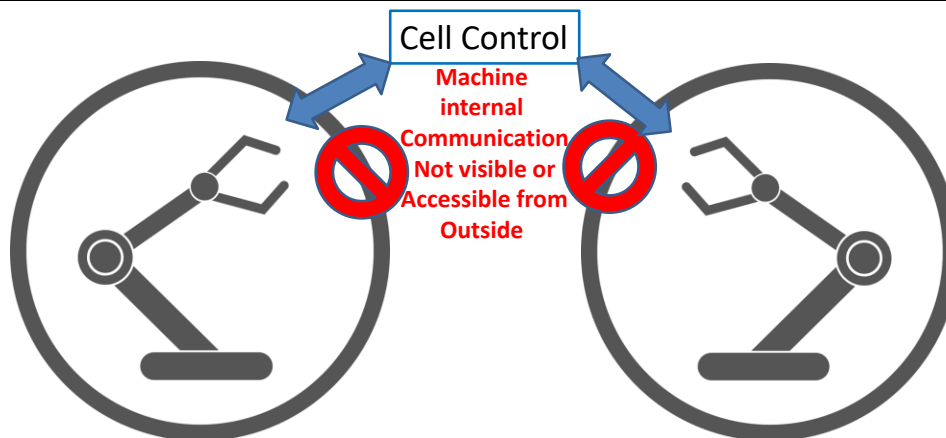

588

589

Figure 27 – Machine internal communication with isolated logical infrastructure

590

Requirements:

591

- TSN domains with unique addressing within the TSN domains;
- Unique TSN domain identification (e.g. using LLDP) also for cloned machines;
- Define handling of specific addresses (e.g. IP addresses) for global identification and how they are managed within the machine set-up procedures;

592

593

594

595

596

597

598

Note: Only supported within a single configuration domain. Not supported across multiple domains.

599

Useful 802.1 mechanisms:

600

- IEEE 802.1Q (usage of streams)
- IEEE 802.1 support for isolation is VLAN

601

602

2.7 Further Industrial Automation Use Cases

603

2.7.1 Use case 08: Security

604

Industrial automation equipment can become the objective of sabotage or spying.

605

Therefore all aspects of information security can be found in industrial automation as well:

606

- Confidentiality "is the property, that information is not made available or disclosed to unauthorized individuals, entities, or processes."
- Integrity means maintaining and assuring the accuracy and completeness of data.
- Availability implies that all resources and functional units are available and functioning correctly when they are needed. Availability includes protection against denial-of-service attacks.
- Authenticity aims at the verifiability and reliability of data sources and sinks.

607

608

609

610

611

612

613

614

Requirement:

615

Optional support of confidentiality, integrity, availability and authenticity.

616

Security shall not limit real-time communication

617

618

619

Note: Limited security for Control Plane only.

620

Protection against rogue applications running on authenticated stations are out of scope.

621

622 **Note: No mechanisms identified for the Data Plane, so no guarantees. (It is expected that**
623 **upper layer protocols will provide Data Plane security.)**

624
625 Useful mechanisms:

- 626 • 802.1X
- 627 • IEC62443
- 628 • ...

629

Abbreviations

AGV	Autonomous Guided Vehicle
CCTV	Closed Circuit Television
DCS	Distributed Control System
FW	Firmware
PA	Process Automation

630

631

632

633

Literature and related Contributions

634

Literature:

635

636

637

[1] "Cyber Physical Systems: Design Challenges", E. A. Lee, Technical Report No. UCB/EECS-2008-8; <http://www.eecs.berkeley.edu/Pubs/TechRpts/2008/EECS-2008-8.html>

638

639

640

[2] Beckers, K. (2015). Pattern and Security Requirements: Engineering-Based Establishment of Security Standards; Springer; ISBN 9783319166643

641

642

643

[3] PI: Isochronous Mode – Guideline for PROFINET IO; V1.0; June 2016; available at <http://www.ieee802.org/1/files/private/liaisons>

644

Related contributions:

645

646

647

[4] LNI traffic patterns for TSN: <http://www.ieee802.org/1/files/public/docs2018/new-Bruckner-LNI-traffic-patterns-for-TSN-0118.pdf>

648

649

650

[5] Multivendor Motion Control: <http://www.ieee802.org/1/files/public/docs2018/new-industrial-enzinger-multivendor-motion-control-0318-v01.pdf>

651

652

653

[6] Hierarchical Domain based Network: <http://www.ieee802.org/1/files/public/docs2018/60802-harima-industrial-use-case-0518-v04.pdf>

654

655

656

[7] Process Automation System Quantities: <http://www.ieee802.org/1/files/public/docs2018/60802-sato-pa-system-quantities-0718-v01.pdf>

657

658

659

[8] TSN Interdomain Communications: <http://www.ieee802.org/1/files/public/docs2018/60802-Hantel-TSN-Interdomain-Communications-0718.pdf>

660

661

662

[9] Cycle Timing Models: <http://www.ieee802.org/1/files/public/docs2018/60802-enzinger-cycle-timing-models-0718-v04.pdf>

663

664

665

[10] Isochronous Drive Synchronization: <http://www.ieee802.org/1/files/public/docs2018/60802-enzinger-use-case-isochronous-drive-synchronization-0718-v01.pdf>

666

667

668

[11] Machine Internal and Machine to Cell Controller (M2C) Embedded Communication: <http://www.ieee802.org/1/files/public/docs2018/60802-essler-additional-use-case-0718-v01.pdf>

- 669 [12] Coexistence & Convergence in TSN-based Industrial Automation Networks:
670 [http://www.ieee802.org/1/files/public/docs2018/60802-stanica-convergence-coexistence-0718-
672 v03.pptx](http://www.ieee802.org/1/files/public/docs2018/60802-stanica-convergence-coexistence-0718-
671 v03.pptx)
- 673 [13] Flexible Manufacturing System (FMS) for Small Batch Customized Production:
674 [http://www.ieee802.org/1/files/public/docs2018/60802-Bai-small-batch-customized-production-
676 0718-v01.pdf](http://www.ieee802.org/1/files/public/docs2018/60802-Bai-small-batch-customized-production-
675 0718-v01.pdf)
- 677 [14] Multi-traffic transmission in industrial backbone network:
678 [http://www.ieee802.org/1/files/public/docs2018/60802-chen-multi-traffic-transmission-on-backbone-
680 0918.pdf](http://www.ieee802.org/1/files/public/docs2018/60802-chen-multi-traffic-transmission-on-backbone-
679 0918.pdf)
681