



Overview of known issues for IEEE 802.1CB FRER ... and next steps

Dr. Lisa Maile, Network Modeling and Design Lab, Electronic Systems Group, Technische Universiteit Eindhoven (TU/e)



SRF &
Refinements

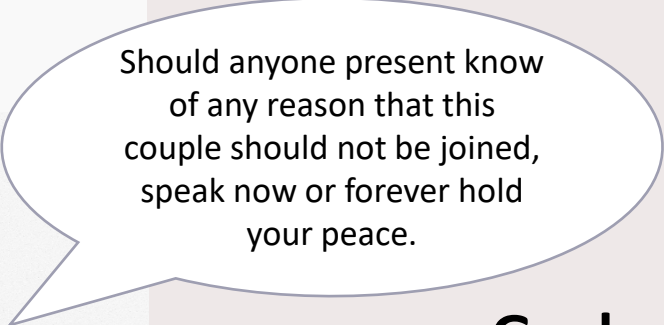

Should anyone present know
of any reason that this
couple should not be joined,
speak now or forever hold
your peace.



this presentation

Goal of this presentation

- Presentation of known issues with the Sequence Recovery Function (SRF) in IEEE Std. 802.1CB
- **Goal is to agree:**
Which issues we do care about & want to get „engaged“ with?



us

This slide is not to be taken seriously!

Identified Issues since 2019

Nominal Behaviour / No Failure	Management Reset
	Member Stream Path Jitter (e.g., inference or wireless)
	Talker Pause
	Network Function Virtualization
Failure	Failure before Duplication (or: Failure on all links)
	Failure on one link
Other	VRA w short HistoryLength
	MRA w/o intermittent streams

Many issues occur even under normal operation!



Resulting Effects



Disclaimer

- Many solutions have been proposed
- **But we will not present the solutions here**
- Let us first agree, if the problems are relevant
- Solutions will be discussed in a separate presentation

References used

[1] Balázs Varga, János Farkas, July 2019

<https://www.ieee802.org/1/files/public/docs2019/new-varga-FRER-improvements-0719-v01.pdf>

[2] Balázs, Farkas, March 2020

<https://www.ieee802.org/1/files/public/docs2020/new-varga-FRER-seamless-reset-0320-v02.pdf>

[3] Maintenance 257, March 2020

<https://www.ieee802.org/1/files/public/docs2020/maint-varga-257-FRER-recovery-window-0320-v01.pdf>

<https://www.802-1.org/items/370>

[4] Balázs, Farkas, March 2020

<https://www.ieee802.org/1/files/public/docs2020/maint-varga-FRER-sequence-recovery-reset-0320-v02.pdf>

[5] Maintenance 265, April 2020

<https://www.802-1.org/items/379>

[6] Balázs, Farkas, Sept 2020

<https://www.ieee802.org/1/files/public/docs2020/new-varga-FRER-RTag-0920-v02.pdf>

[7] Balázs, Farkas, Fejes, Hoeffberger et al., May 2023

<https://www.ieee802.org/1/files/public/docs2023/new-varga-FRER-extensions-to-support-cloudification-0523-v01.pdf>

[8] Maile et al., Jun 2023

<https://www.ieee802.org/1/files/public/docs2023/new-maile-ensuring-reliable-and-predictable-behavior-of-FRER-0623-v02.pdf>

[9] Maile, June 2024

<https://www.ieee802.org/1/files/public/docs2024/new-maile-FRER-sequence-recovery-configuration-0624-v01.pdf>

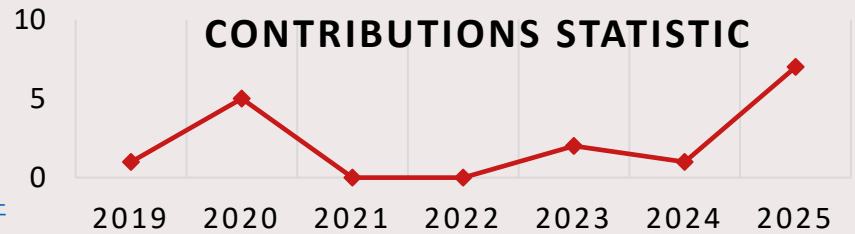

[10] IEEE Std. P802.1CBec, Feb 2025 - now

<https://www.ieee802.org/1/files/private/ec-drafts/d0/802-1CBec-d0-2.pdf>

[11] Maintenance 378, March 2025

<https://www.ieee802.org/1/files/public/docs2025/maint-arunarthi-CB-2017-item-378-0310-v02.pdf>

[12] Balázs, Farkas, May 2025

<https://www.ieee802.org/1/files/public/docs2025/maint-varga-CB-2017-item-378-FRER-segrereset-0525-v00.pdf>

[13] McCall May 2025

<https://www.ieee802.org/1/files/public/docs2025/maint-mccall-cb-2017-item-378-seq-recovery-options-v01.pdf>

[14] Balázs, Farkas, July 2025

<https://www.ieee802.org/1/files/public/docs2025/maint-varga-CB-2017-item-378-FRER-reset-analysis-0725-v01.pdf>

[15] Steindl, Proell, July 2025

<https://www.ieee802.org/1/files/public/docs2025/60802-Steindl-Proell-IA-Controller-ConfDomain-Cloud-0725-v01.pdf>

[16] Balázs, Farkas, September 2025

<https://www.ieee802.org/1/files/public/docs2025/ec-varga-FRER-improvements-0925-v00.pdf>

[17] Extending PAR&CSD for P802.1CBec, Nov 2025

<https://www.ieee802.org/1/files/public/docs2025/ec-draft-PAR-modification-0925-v01.pdf>
<https://www.ieee802.org/1/files/public/docs2025/ec-draft-CSD-modification-0925-v01.pdf>

... let me know if something is missing!

Notation

d_{BC} = Minimum time from the sending of a packet to its earliest possible arrival at the SRF, considering any Member Stream

d_{WC} = Maximum time from the sending of a packet to its latest possible arrival at the SRF, considering any Member Stream

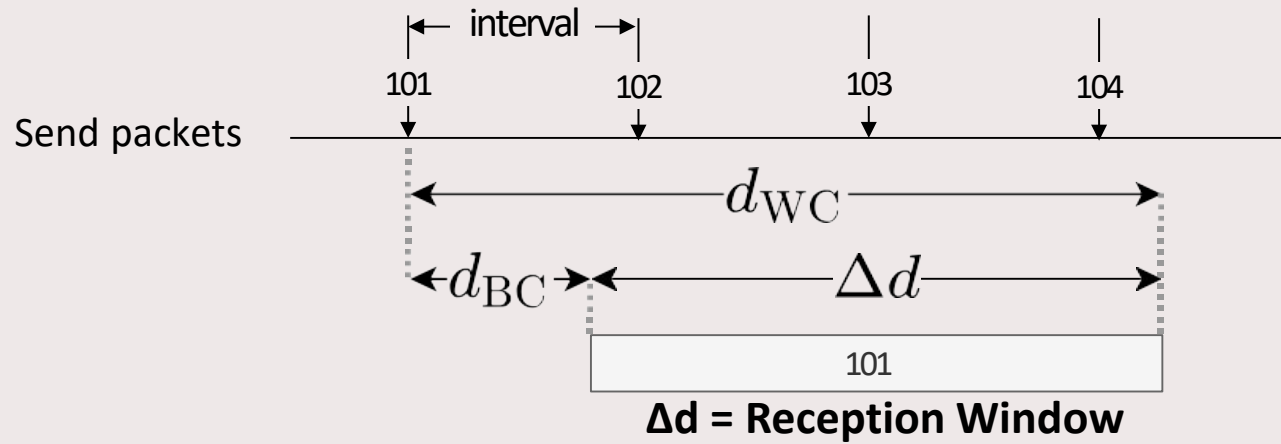

Assumption on the next slides: SRF with Vector Recovery Algorithm

Vector Recovery Algorithm

Seq. Window, with HistoryLength = 5

Seq. History

Sequence Window	Next Packet Seq. Nr	Explanation	Passed	Discarded	Replicate	Rogue	Out of Order
	n+...	Outside of Acceptance Interval		✓		✓	
	n+5	Within Acceptance Interval, shift RecovSeqNum	✓				✓
	n+4		✓				✓
	n+3		✓				✓
	n+2		✓				✓
	n+1						
1	RecovSeqNum n	In Seq. History and Received		✓	✓		
1	n-1			✓	✓		
0	n-2	In Sequence History and not Received	✓				✓
0	n-3		✓				✓
1	n-4	In Seq. History and Received		✓	✓		
	n-5	Outside of Acceptance Interval		✓		✓	
	n-...			✓		✓	

SequenceRecoveryReset

- Resets SRF if no packet is accepted and forwarded for the duration of frerSeqRcvyResetMSec (timeout)
- All entries in Seq. History set to 0
- TakeAny = True, which means that RecovSeqNum will take the value of the next packet received

Ideal Operation

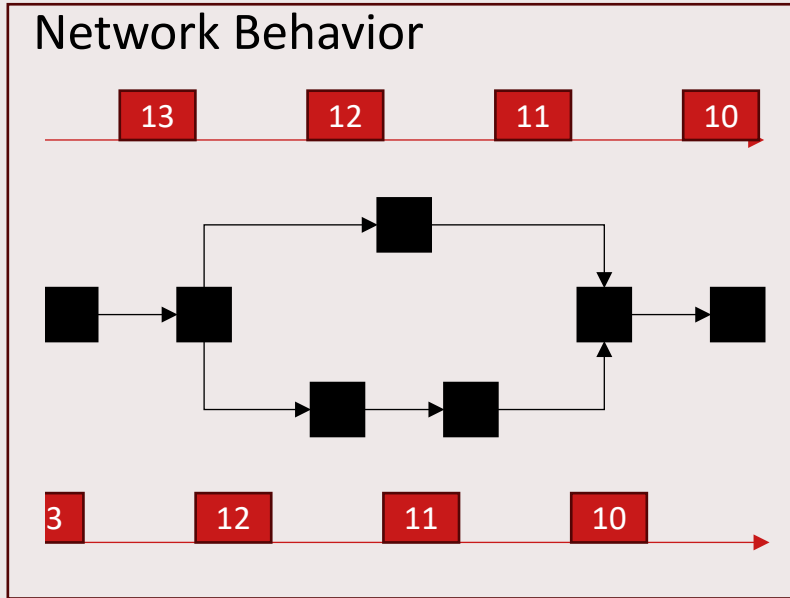

Under ideal operation (i.e., periodic, no/low jitter)

- RecoverSeqNum = highest received SeqNum (e.g., 0x09 at the beginning, 0x13 at the end of the figure)
- All SeqNums within Sequence Window
- Replicates → eliminated
- Valid packets → forwarded

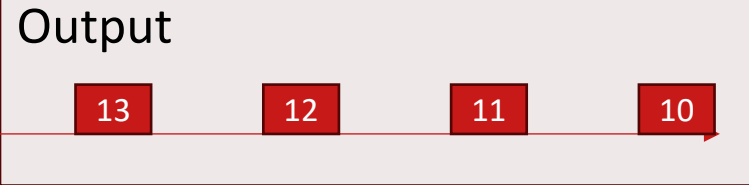

Grey boxes mean “no issue”

Wrong Counter Values

Forwarding of Replicates

Increased Rate of Merged Stream

Elimination of Valid Packets

Nominal Behavior: Management Reset

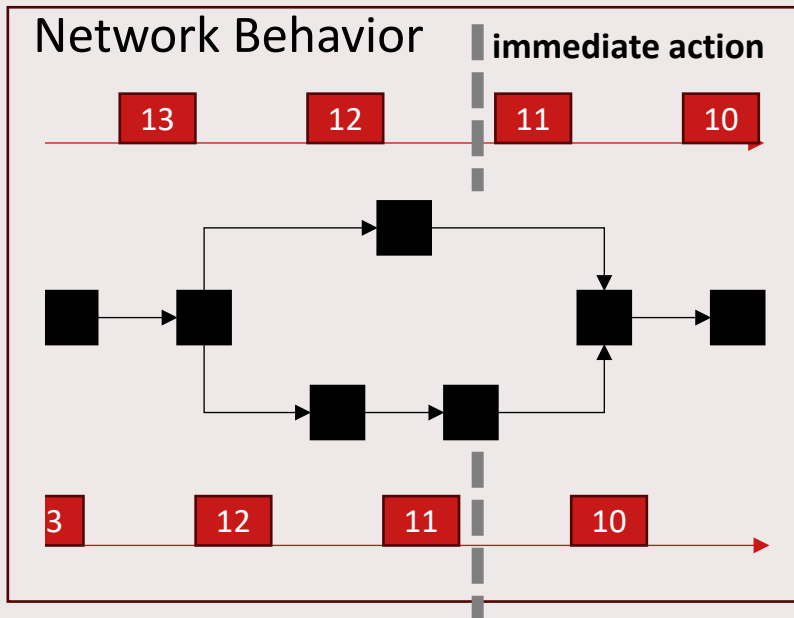

Two Types of Management Resets

1. BEGIN event related reset

- For initial startup of node, resets all functions
- Expected behavior (= no history)

2. frerSeqRcvyReset = True

- Manually triggers SequenceRecoveryReset for stream
 - All entries in SequenceHistory set to 0
 - TakeAny (RecoverSeqNum = next rcv. packet, e.g., 0x10)
- Previously rcv. packet (e.g., 0x11) forwarded → **Replicate**
- **#HistoryLength** packets counted as lost (e.g., 0x08 and 0x09 for HistoryLength = 2)
- **Increased rate** due to Replicates

Output

No. of Replicates depends on Δd



Red boxes mean “issue”

Wrong
Counter
Values

Forwarding
of
Replicates

Increased
Rate of
Merged
Stream

Elimination
of Valid
Packets

Nominal Behavior: Member Stream Jitter

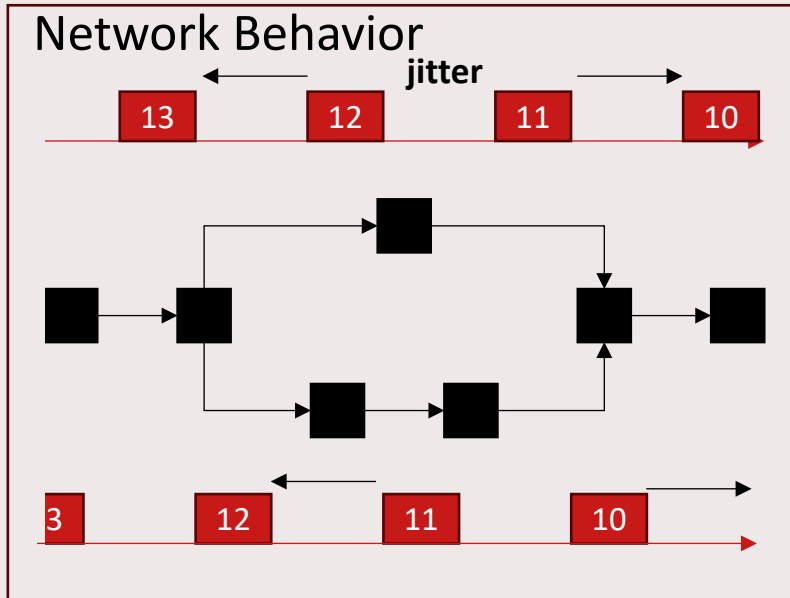

Jitter on Path
(e.g., due to interference or wireless transmission)

Output

Wrong
Counter
Values

Forwarding
of
Replicates

Increased
Rate of
Merged
Stream

Elimination
of Valid
Packets

Nominal Behavior: Member Stream Jitter

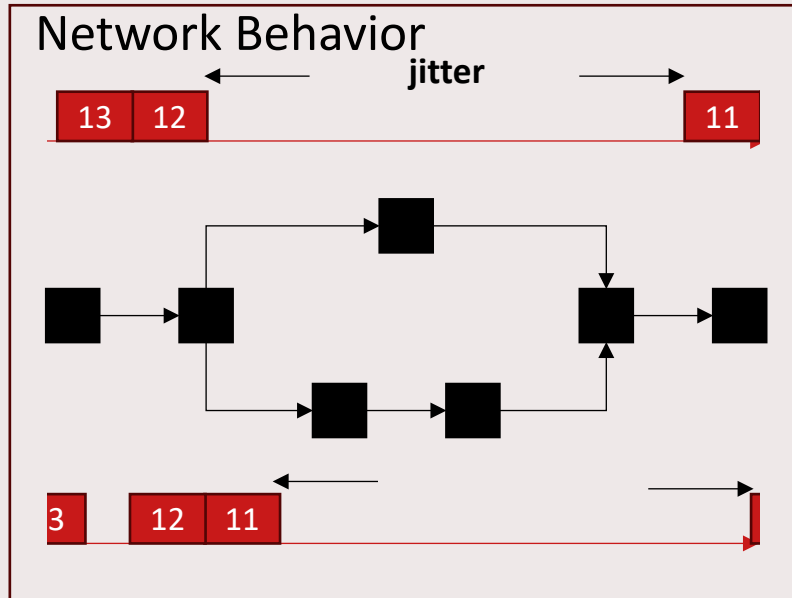

Jitter on Path

(e.g., due to interference or wireless transmission)

- Jitter can lead to long idle time
- Can trigger SequenceRecoveryReset
- Same effects as before
(Replicates, increased rate, loss counter)
- There is nothing that protects a user from this error

Output

No. of Replicates depends on Δd

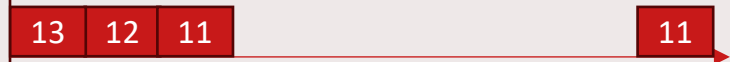

Wrong
Counter
Values

Forwarding
of
Replicates

Increased
Rate of
Merged
Stream

Elimination
of Valid
Packets

Nominal Behavior: Talker Pause

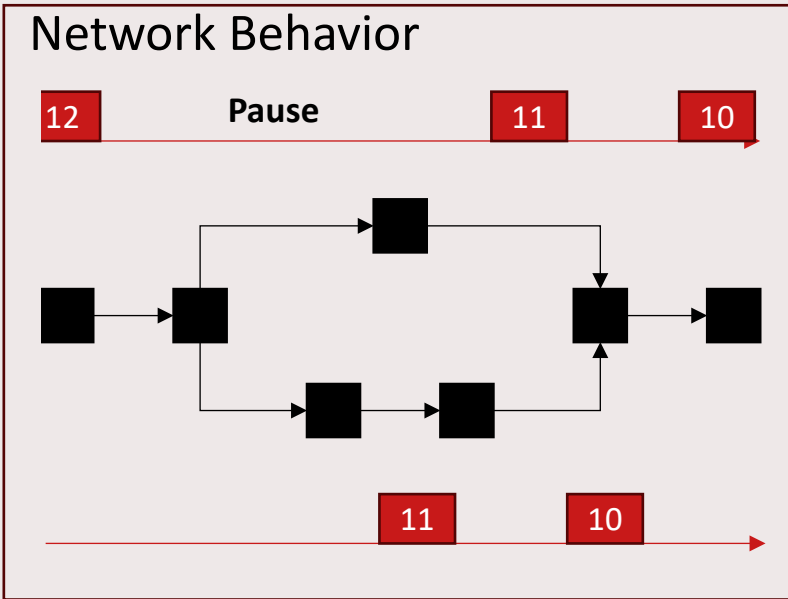

Talkers are allowed to pause or send less

- Pauses can be arbitrarily long and **arbitrarily often**
- Will trigger SequenceRecoveryReset
- Each time **loss counter increases by #HistoryLength**

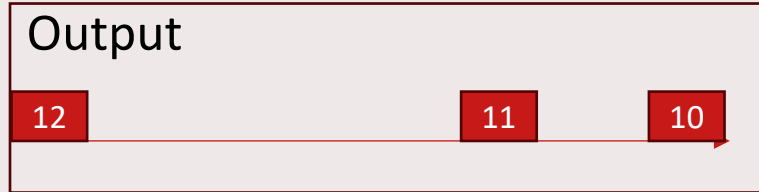

Wrong Counter Values

Forwarding of Replicates

Increased Rate of Merged Stream

Elimination of Valid Packets

Nominal Behavior:

Network Function Virtualization (NFV)

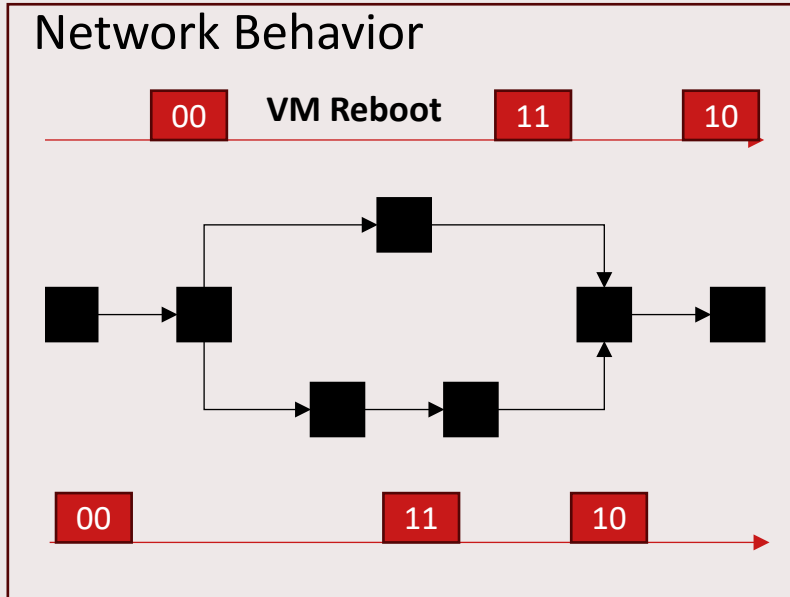

Virtualization (e.g., containers, virtual machines)

- FRER functionality might be part of the cloud
- Virtual instances can restart fast
- Next SeqNum arbitrary (e.g., 0x00)
- No timeout → Seq. Window not reset
- **Valid packets discarded** (e.g., 0x00 and following)
→ outside current Seq. Window
- Will trigger SequenceRecoveryReset after timeout, then same issues as for **Talker Pause** (**loss counter**)

Output



Wrong
Counter
Values

Forwarding
of
Replicates

Increased
Rate of
Merged
Stream

Elimination
of Valid
Packets

Failure Behavior: Failure before Duplication

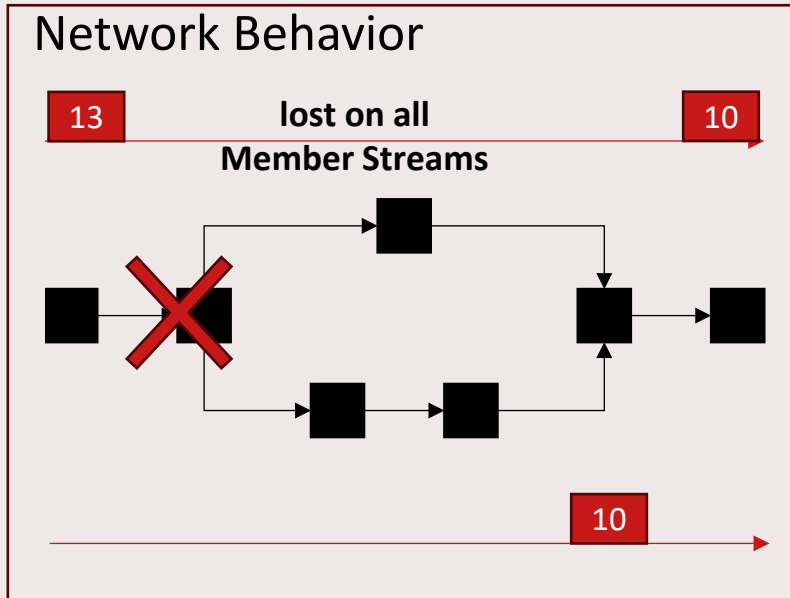

All Replicates are lost

(e.g., due to failure before duplication if FRER is in relay node or failure on all links)

- Time of failure can be arbitrary
- Next Sequence Number can be arbitrarily higher (e.g., 0x13 or any higher number)
- **Valid packets discarded** (e.g., 0x13 and following)
→ outside current Seq. Window
- Will trigger SequenceRecoveryReset after timeout, then same issues as for **Talker Pause** (**loss counter**)
- Can be covered as trade-off between the Reset Timeout value and History Length, but careful config. required.

Output

0x13

10

and following packets lost



Wrong
Counter
Values

Forwarding
of
Replicates

Increased
Rate of
Merged
Stream

Elimination
of Valid
Packets

Failure Behavior:

Failure on one Link

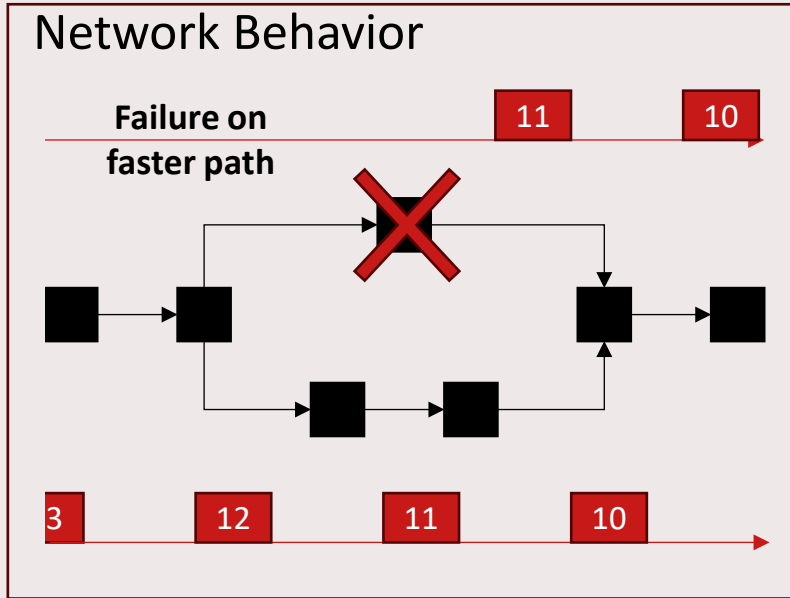

Faster Link Failure & Recovery

- Main Use Case of FRER
- Invisible to the application
- Exhibits three phases:
 - 1) Small delay
 - 2) Reception by slower path

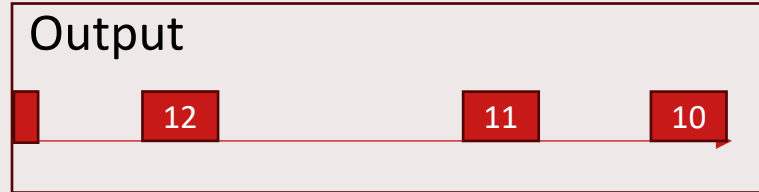

Wrong Counter Values

Forwarding of Replicates

Increased Rate of Merged Stream

Elimination of Valid Packets

Failure Behavior:

Failure on one link

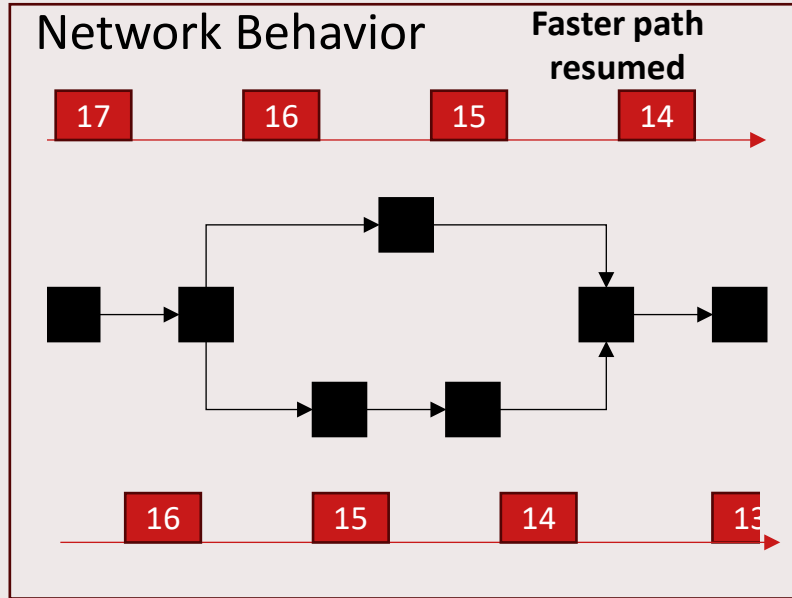

Faster Link Failure & Recovery

- Main Use Case of FRER
- Invisible to the application
- Exhibits three phases:
 - 1) Small delay
 - 2) Reception by slower path
 - 3) After recovery, doubled rate of streams

Better illustration on the next slide

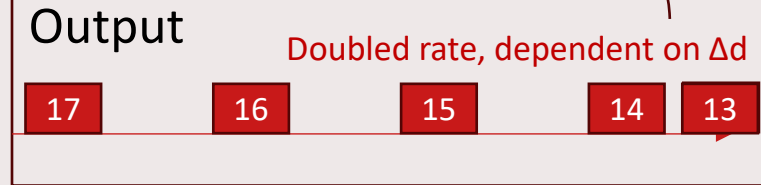

Wrong Counter Values

Forwarding of Replicates

Increased Rate of Merged Stream

Elimination of Valid Packets

Failure Behavior: Failure on one link

- Failure transparent to SRF (no timeout, no loss counter, ...)
- SRF might be relay node → Burst of packets forwarded (**doubled the reserved rate**)*
- SRF does not re-shape the flow, neither does SP and CBS → **has to be considered in subsequent nodes**
- **Careful!**
 - **Changes the latency** in succeeding hops for SP & CBS
 - **Changes the latency** at SRF for all schedulers, also ATS
 - **Changes parameters** for Per Stream Filtering and Policing (**nowhere considered yet**)

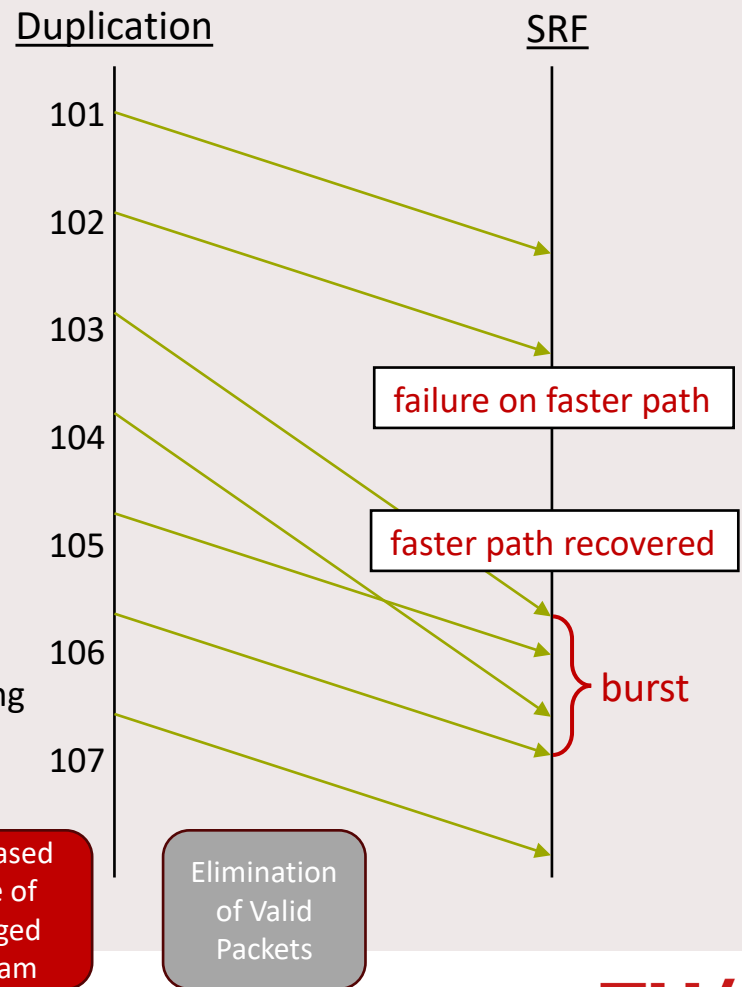

Wrong Counter Values

Forwarding of Replicates

Increased Rate of Merged Stream

Elimination of Valid Packets

* does not increase further, if #pat

Additional Note on VRA

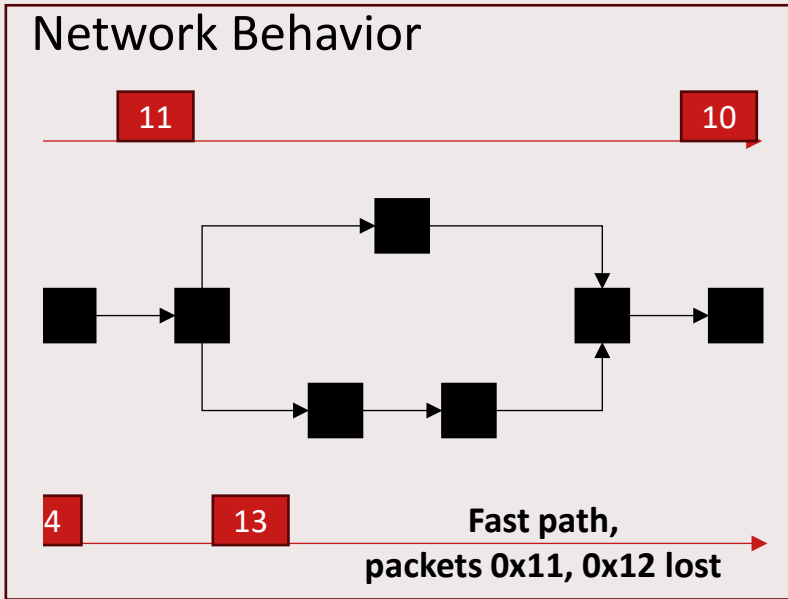

VRA and HistoryLength

- VRA requires parameter HistoryLength
- Large path delay differences (Δd)
→ relevant in, e.g., in ring topologies
- Too short HistoryLength → **valid packets discarded**
Example: RecovSeqNum = 0x10, HistoryLength = 2
→ packet 0x13 lost (counted as Rouge)
- Problem arises if packets on one link are lost
- Packets from faster path (e.g., 0x13) are dropped
- No guarantee they arrive via slower path
→ risk of complete loss (especially when considering wireless)

Output

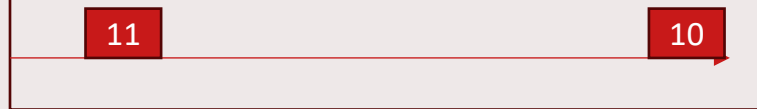

Wrong Counter Values

Forwarding of Replicates

Increased Rate of Merged Stream

Elimination of Valid Packets

Additional Note on VRA (continued)

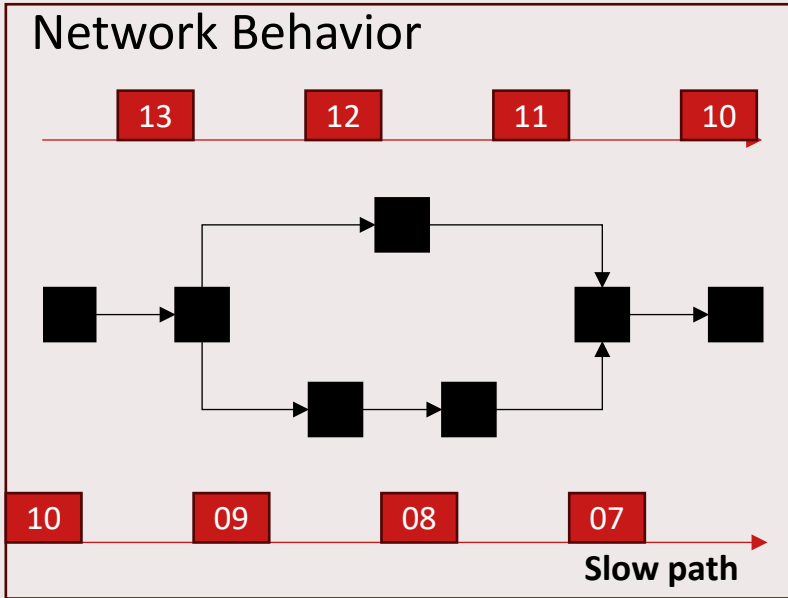

The issue on the previous slide can also happen the other way around

- Slow paths might transmit so slow that packets are out of the Seq. Window (ring topologies!)
- Should be counted as Duplicates, but will be counted as Rouge
- Can be constant, or only occasional, if jitter is high



Wrong Counter Values

Forwarding of Replicates

Increased Rate of Merged Stream

Elimination of Valid Packets

Assumption on the next slide: SRF with Match Recovery Algorithm

Match Recovery Algorithm (MRA)

- stores only highest sequence number received
- only eliminates Replicates with this (one!) sequence number
- **requires** intermittent streams

- no guidance on how intermittent streams are guaranteed, if wrong:
→ **(constant) forwarding of Replicates**

Wrong
Counter
Values

Forwarding
of
Replicates

Increased
Rate of
Merged
Stream

Elimination
of Valid
Packets

Discussion

Wrong Counter Values	Forwarding of Replicates	Increased Rate of Merged Stream	Elimination of Valid Packets
----------------------	--------------------------	---------------------------------	------------------------------

Nominal Behaviour / No Failure	Management Reset				
	Member Stream Path Jitter (e.g., inference or wireless)				
	Talker Pause				
	Network Function Virtualization				
Failure	Failure before Duplication (or: Failure on all links)				
	Failure on one link				
Other	VRA w short HistoryLength		Nominal Behavior		Failure on one link
	MRA w/o intermittent streams				

Thank you