

QoS on IEEE 802.3 10BASE-T1S — IEEE 802.1 Aspects —

Johannes Specht [Independent]

Background & Need

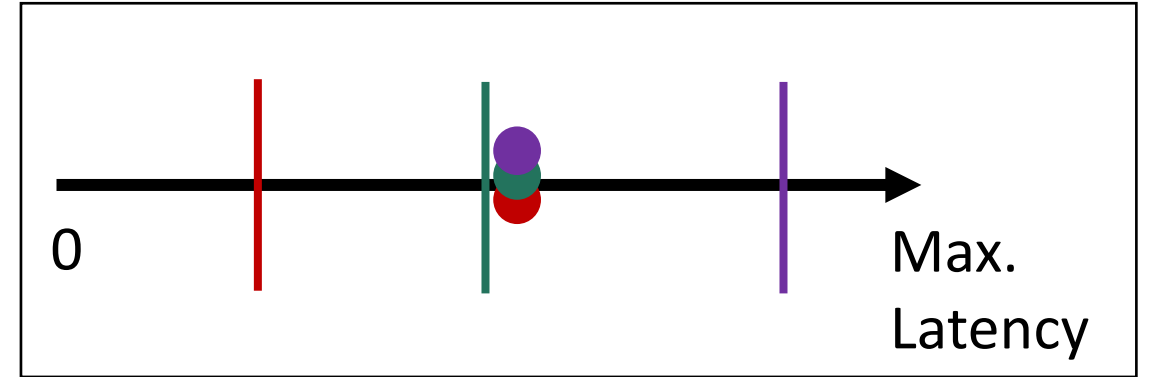
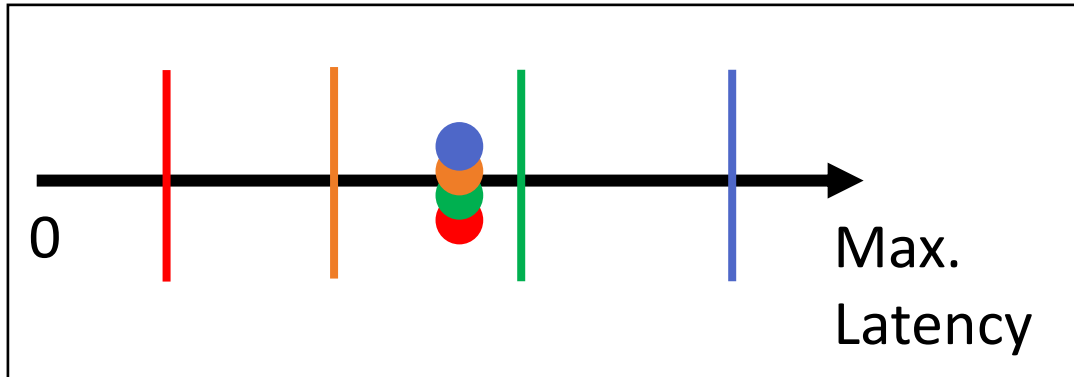
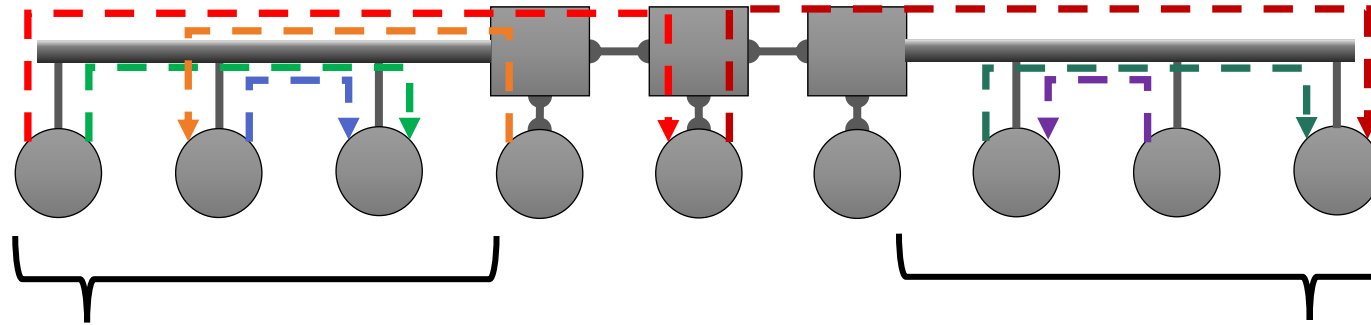

Background & Need

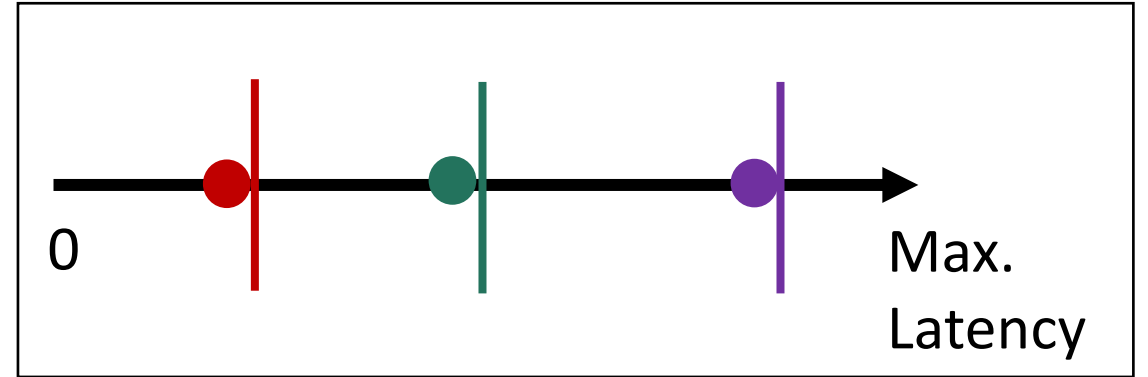
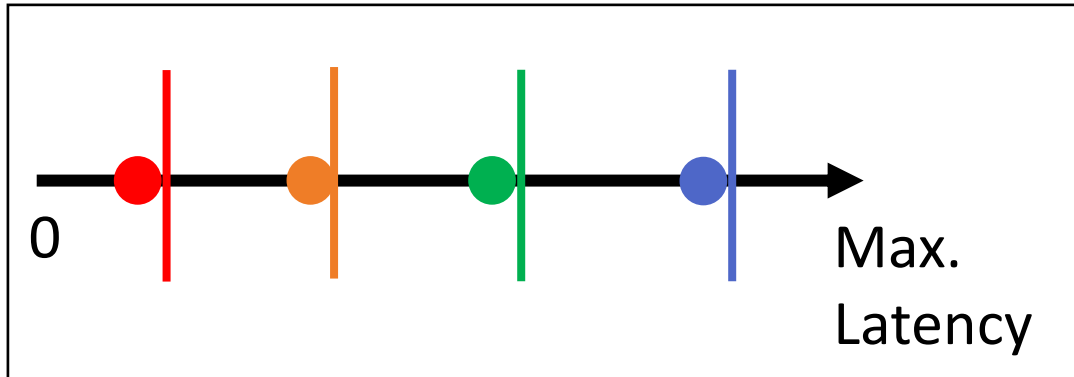
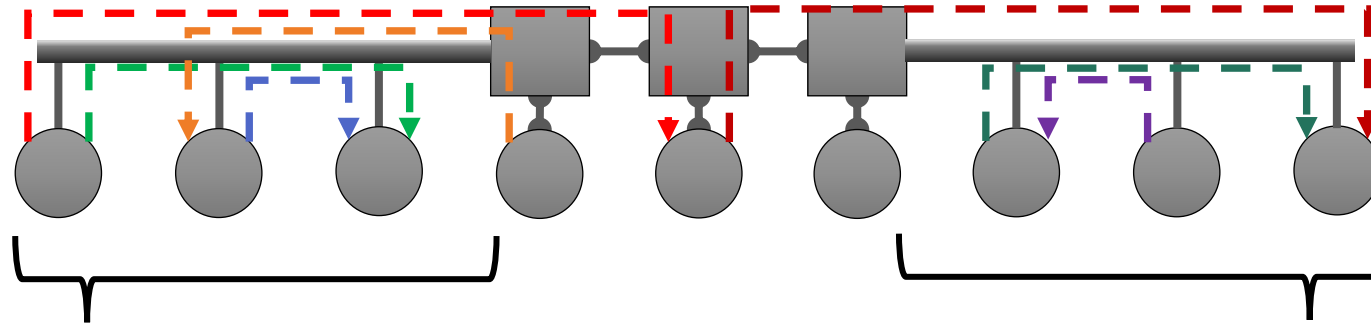

➔ *Max. Latency Differentiation*

From the Oct. 2025 Slides in IEEE 802.3 NEA

Desired behavior:

- Differentiate between nodes with different latency requirements
- Example:
 - Low Latency nodes can send frequently (e.g., in every cycle)
 - Medium latency nodes send less frequently (e.g., in every other cycle)
 - Best effort nodes send infrequently (e.g., in every fourth cycle)

cycle	Node N0	Node N1	Node N2	Node N3	Node N4	Node N5	Total
1	X	X			X		3
2	X		X	X			3
3	X	X				X	3
4	X		X	X			3
5	X	X			X		3
6	X		X	X			3
7	X	X				X	3
8	X		X	X			3
9	X	X			X		3
10	X		X	X			3
11	X	X				X	3
12	X		X	X			3
13	X	X			X		3
14	X		X	X			3
15	X	X				X	3
16	X		X	X			3

┌──────────┐ ┌──────────────────┐ ┌──────────────────┐
Low Latency Node Medium Latency Nodes Best Effort Nodes

Key idea:

- Limit the number of nodes that can send in any cycle to a small constant number !
- Latency is no longer a direct function of the number of nodes on the network.

Source: https://www.ieee802.org/3/ad_hoc/ngrates/public/calls/25_1009/2025_10_09a_NEA_Differentiated_Services_10BaseT1S-v1-no-backup.pdf

Fair Arbitration & Regulated Priority Arbitration

Fair arbitration

Max. Bandwidth

Work-conserving:
allocated share, or more (if unused by others)

Max. Latency

- Unequal shares/weights²:
 - Higher share → Lower max. latency
 - Lower share → Higher max. latency
- Equal bandwidth(!) shares
→ Equal max. latency

Regulated¹ priority arbitration

Max. Bandwidth

Non-work conserving:
allocated share

Max. Latency

- Higher priority → Lower max. latency
- Lower priority → Higher max. latency

1: Prevents starvation of lower priorities – can be established by shapers per IEEE 802.1 Standards, or by methods on higher ISO/OSI layers with similar effect in end stations.

2: For example, see WRR or WFQ and associated math.

Standardized QoS Elements in a Port

IEEE 802.1 Stds

1. Transmission selection algorithms:
 - Strict Priority algorithm (SP)
 - Asynchronous Traffic Shaper (ATS)
 - Credit-based shaper algorithm (CBS)
 - Bandwidth regulation (ATS&CBS)
2. Per-Port Static Priority Arbitration w. Traffic Classes (TC)
 - Max. latency differentiation
3. Enhancements for Scheduled Traffic (EST)
 - Time-Division Multiplexing (TDM) per-LAN, per-Port, both, and more

IEEE Std 802.3

PLCA with Multidrop

- Per-LAN fair arbitration (between stations)
- Bandwidth equalization
- Max. latency equalization

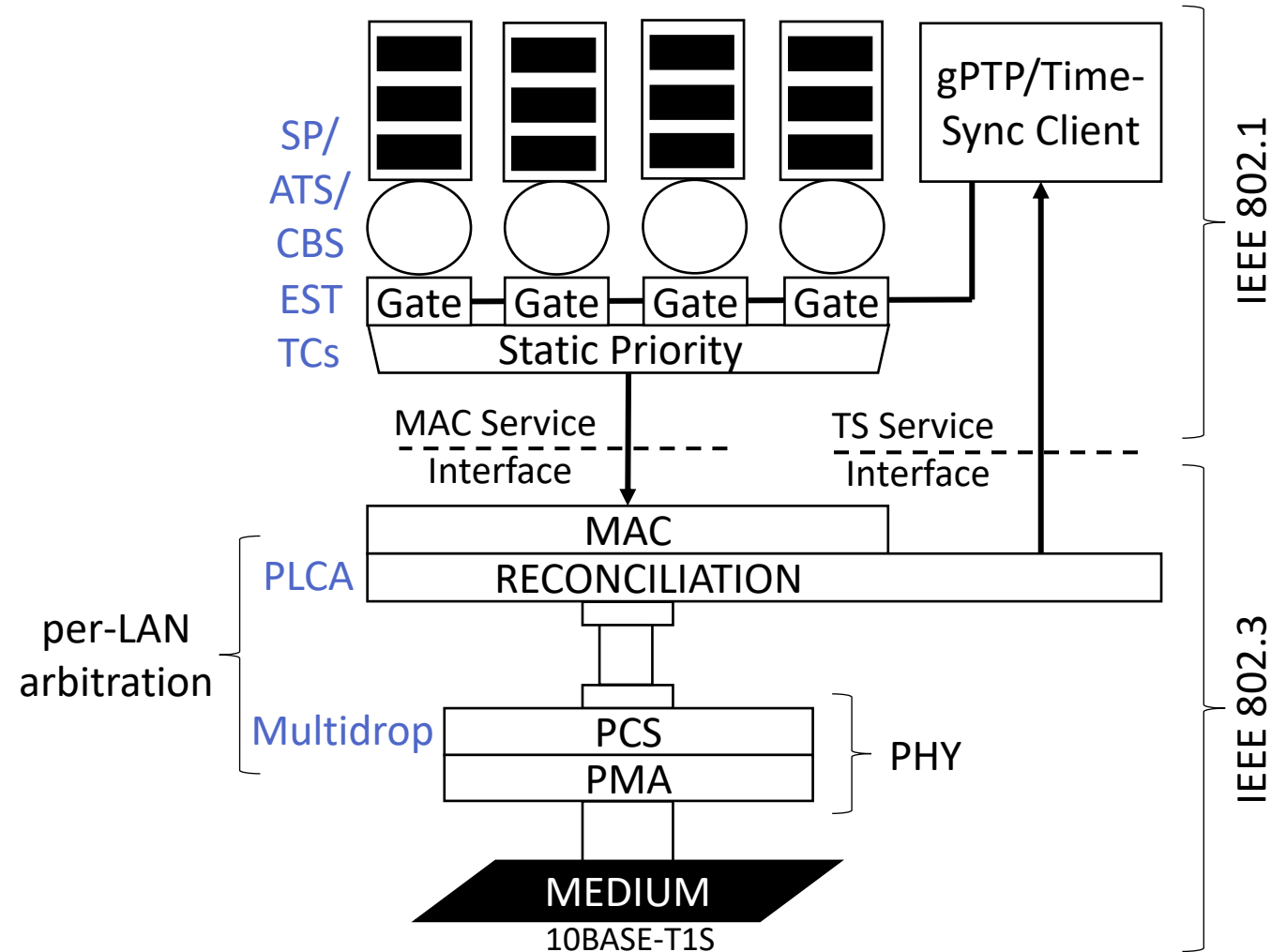

Remark: Simplified/subset - see IEEE Stds 802, 802.1Q, 802.1AC, 802.1DC, 802.1AS and 802.3 for the full and exact definitions.

Passing priorities down the stack

Option: Priority-parameter in MAC service primitives (IEEE 802.1AC)

- Not used for IEEE Std 802.3 yet, but used for other LMSC MAC/PHY Stds
- In IEEE Std 802.1AC: Small changes
- In IEEE Std 802.3: Unclear

Option: Parallel MAC service interfaces mapped to priorities

- Preemption-like approach, successful with IEEE Std 802.3
- Priority to MAC service interface mapping (IEEE 802.1AC): 1-to-1, configurable (cmp. preemption), ...

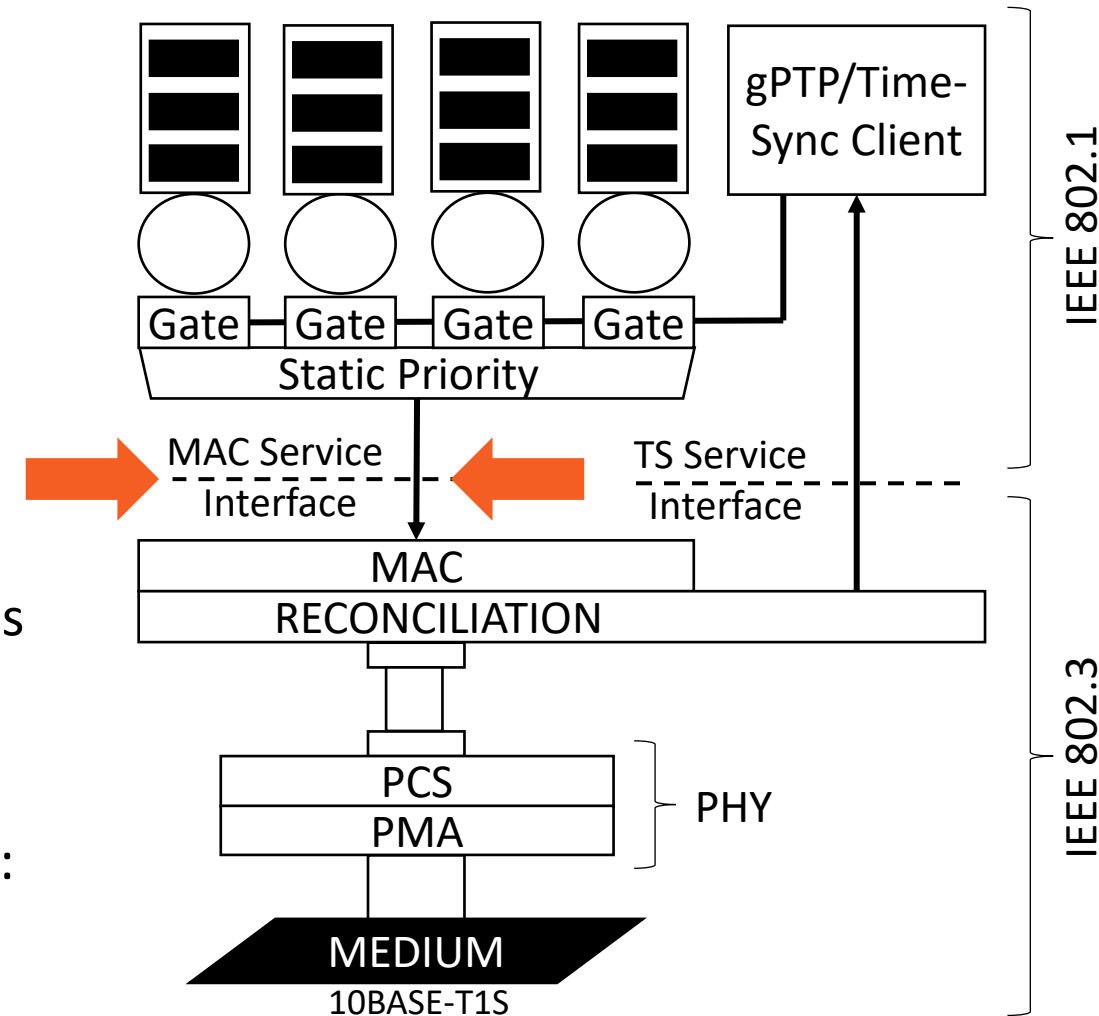

Remark: Simplified/subset - see IEEE Stds 802, 802.1Q, 802.1AC, 802.1DC, 802.1AS and 802.3 for the full and exact definitions.

More than priorities

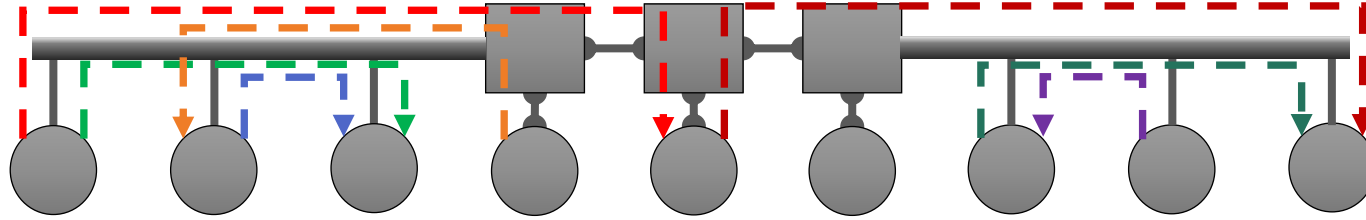

- TDM – may not be precluded

- Extra latency for collision resolution may be unacceptable for some applications
- Applications timings need to be aligned with transmission slots
 - Known “cost” of TDM

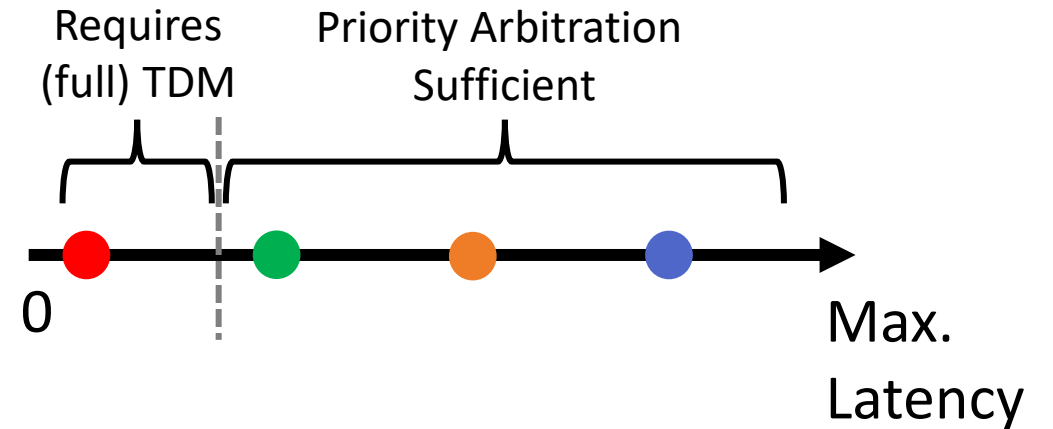

- Per-LAN fair arbitration – may not disappear

- Co-existing non-control applications, requiring higher bandwidth utilization rather than lower latency
- Backwards compatibility

Priority, TDM & Fair Arbitration

Option: Fair and (Prio.+TDM) Phases



- Phase duration configured via gate control list
- Potential additional transition indication via special gate control entry (e.g., using a MMSI-like interface)
- Lightweight time synchronization (local to the shared medium) may be sufficient

Option: Fair Arbitration at lowest priority

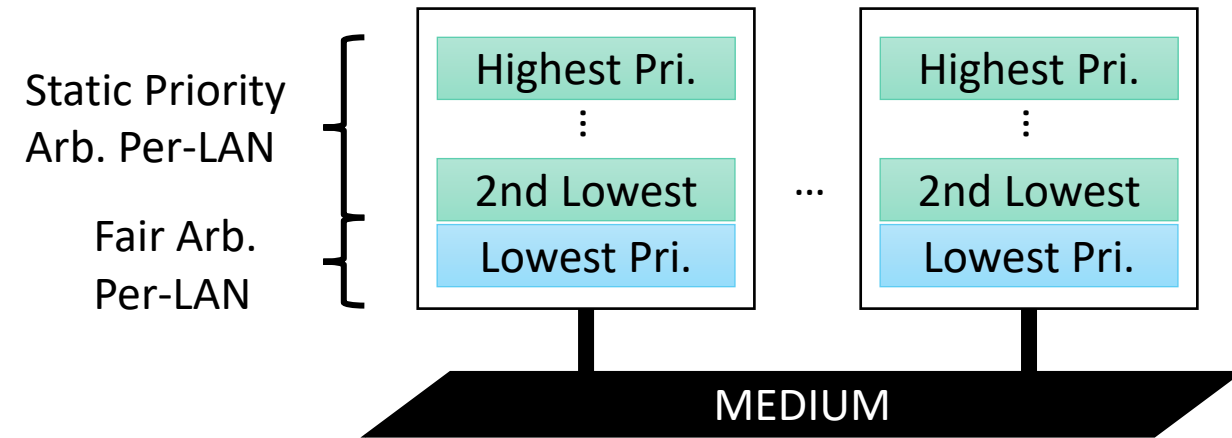

- Fine-grained alteration between fair arbitration/static priority & TDM
- Most details in IEEE 802.3 scope

*Coordination with IEEE WG 802.3 appears necessary
(i.e., IEEE 802.3 NEA and IEEE 802 Nendica)*

Summary & Conclusion

- There is the need for QoS, max. latency differentiation in particular, in IEEE 802.3 10BASE-T1S:
 - Static priority is a tool commonly used for such purposes, enjoying decoupling from bandwidth and max. latency
 - Full TDM may not be precluded, because it allows for the lowest max. latency
- On the per-Port level, arbitration decisions and regulation appears to be within IEEE 802.1
- On the per-LAN level, arbitration appears to be within IEEE 802.3
- There are options:
 - Passing priority down the stack for priority arbitration on per-LAN level
 - Adding priority & TDM while retaining fair arbitration
- Coordination and joint discussion between IEEE 802.1 and IEEE 802.3 appears necessary (i.e., IEEE 802.3 NEA and IEEE 802 Nendica)

Thank You for Your Attention!

Questions,
Comments,
A.o.B.?

Johannes Specht
M +49 (0)170 718-4422
johannes.specht.standards@gmail.com

14-May-26

QoS on IEEE 802.3 10BASE-T1S — IEEE 802.1 Aspects

Johannes Specht

11