

**IEEE P802.11
Wireless LANs**

**Proposed Text for Offset Quadrature Modulation (OQM)
based 5 GHz High Speed PHY**

Date: January 1998

Author: Naftali Chayat
BreezeCom
Atidim Tech. Park, Bldg. 1, Tel-Aviv 61131, Israel
Phone: +972-3-6456262
Fax: +972-3-6456290
e-Mail: naftalic@breezecom.co.il

Abstract

This document brings a proposed text for a Supplement to a 802.11 Standard describing a 21 Mbit/s to 50 Mbit/s (and beyond) Physical Layer based on Offset Quadrature Modulation (OQM), in the 5 GHz band.

There are some changes relatively the scheletal proposal of November 1997, as it appears in document 98/111. The main changes are the following:

The symbol rate was changed from the HIPERLAN compatible rate to 25 Msymbol/s. As a side effect, it creates a convenient center frequency grid relative to regulatory boundaries.

The rate encoding is a 4 bit field. Two bits are for ECC method. In addition to Interleaved Hamming code, there is an optional uncoded mode, enabling better utilization, when channel quality permits. Two more options are reserved for possible future modes. Two bits are for numer of bits/symbol, representing 1 to 4 - enabling encoding of data rates up to 100 MHz. Even though, say, 75 Mbit/s with 8-level modulation is hardly practical, as a particular example, 8 level modulation can be used in the future in conjunction with trellis coding to obtain a more robust 50 Mbit/s mode.

A new interleaver structure is introduced. The interleaver structure differs from HIPERLAN in a way which avoids entirely the pre-read latency on the transmit side.

The PLCP header encoding differs from what described in 97/111 - here a more traditional approach is taken. The main reason is not to burden the implementation with different ECCs, and let the header enjoy better interleaving.

Editorial note

The document is the proposed normative part which is intended to be part of the standard. The proposed normative part of the document is structured after the Frequency Hopping part of the 802.11 Standard. For the sake of readability (and to save some trees) all text which repeats the old text is shortened into "SAME" sentence. Same practice is used with subclauses in which no change is done other than replacing "FH" or "FHSS" or "Frequency Hopping" with "OQM". Some of the figures, mostly state machines are not brought here.

1. Offset Quadrature Modulation (OQM) Physical Layer Specification for the 5 GHz Band

1.1 Introduction

This clause describes the physical layer for the 5 GHz high speed Offset Quadrature Modulation (OQM) system. The OQM is initially aimed for the U-NII band as provided in USA according to Document FCC 15.4xx. The lowest sublayer of the OQM physical layer is similar in many respects to the ETSI HIPERLAN type 1 standard as to facilitate possible future usage of the 802.11 OQM PHY devices in Europe in a band which today is devoted solely to HIPERLAN type 1 compliant devices.

The Offset Quadrature Modulation (OQM) includes Offset Quadrature Phase shift Keying (OQPSK) as its lowest sublayer and an Offset Quadrature Amplitude Modulation (Offset QAM, OQAM) at its higher sublayers. The pulse shape used is chosen to provide very small amplitude variations in the binary mode and therefore negligible performance degradation when saturated amplification is utilized in the transmitter RF path. The saturated OQPSK signal is virtually equivalent to Gaussian Minimum Shift Keying (GMSK). This property further facilitates the possibility of differential detection of the signal in the receiver.

The OQM physical layer employs an Error Correction Coding (ECC) based on (31,26,3) Hamming code (sometimes a shortened Hamming code) in conjunction with an interleaver to be described later. The ECC can be disabled on a per-packet basis in order to avoid the 26/31 rate loss, when link quality permits.

The OQM physical layer supports multiple data rates, with higher data rates demanding stronger receive signal. Stations at smaller distance may operate thus at higher speeds and release the medium for a larger fraction of time to stations farther away. The data rates supported by the OQM physical layer range from 21 Mbit/s in OQPSK mode with Error Correction Coding (ECC) enabled to multiples (by a factor ranging from 1 to 4) of 25 Mbit/s in OQAM mode with ECC disabled (with 50 Mbit/s probably being a realistic limit).

The implementation of the slower OQPSK mode is mandatory, while support of the faster OQAM mode is optional. The support of Error Correction Coding is mandatory.

1.1.1 Introduction to OQM Physical Layer

This clause describes the physical layer services provided to the 802.11 Wireless LAN MAC by the 5 GHz Offset Quadrature Modulation (OQM) system. The OQM physical layer consists of the following two protocol functions:

SAME

1.1.2 OQM Physical Layer Functions

The 5 GHz OQM Physical Layer architecture is shown in Figure 11. The OQM physical layer contains three functional entities: the physical medium dependent function, the physical layer convergence function, and the physical layer management function. Each of these functions is described in detail in the following subclauses.

The OQM Physical (PHY) Layer service is provided to the Medium Access Control entity at the station through a PHY Service Access Point (SAP) as shown in Figure 11 called the PHY SAP. A set of primitives are also defined which describe the interface between the physical layer convergence protocol sublayer and the physical medium dependent sublayer called the PMDSAP.

1.1.2.1 Physical Layer Convergence Procedure Sublayer

SAME

1.1.2.2 Physical Layer Management Entity (LME)

SAME

1.1.2.3 Physical Medium Dependent Sublayer

SAME

1.1.3 Service Specification Method and Notation

SAME

1.2 OQM PHY Specific Service Parameter Lists

1.2.1 Introduction

The architecture of the 802.11 MAC is intended to be physical layer independent. ... SAME ... This subclause addresses the TXVECTOR and RXVECTOR for the OQM PHY.

All of the values included in the TXVECTOR or RXVECTOR described in this subclause are considered mandatory unless otherwise specified. The multiples (by a factor ranging from 1 to 4) of 20.968 Mbit/s and 25.0 Mbit/s are the only rates currently supported. Other indicated data rates are for possible future use.

1.2.2 TXVECTOR Parameters

The following parameters are defined as part of the TXVECTOR parameter list in the PHY-TXSTART.request service primitive.

Parameter	Associate Primitive	Value
LENGTH	PHY-TXSTART.request (TXVECTOR)	1-4095
DATARATE	PHY-TXSTART.request (TXVECTOR)	20.9677 Mbit/s, 25.0000 Mbit/s, 41.9355 Mbit/s, 50.0000 Mbit/s, 62.9032 Mbit/s, 75.0000 Mbit/s, 83.8710 Mbit/s, 100.0000 Mbit/s

Table 28, TXVECTOR Parameters

1.2.2.1 TXVECTOR LENGTH

SAME

1.2.2.2 TXVECTOR DATARATE

The DATARATE parameter describes the bit rate at which the PLCP should transmit the PLCPPDU. Its value can be any of the rates as defined in Table 28, TXVECTOR Parameters, and supported by the conformant OQM PHY.

1.2.3 RXVECTOR Parameters

The following parameters are defined as part of the RXVECTOR parameter list in the PHY-RXSTART.indicate service primitive.

Parameter	Associate Primitive	Value
LENGTH	PHY-RXSTART.indicate (RXVECTOR)	1-4095
RSSI	PHY-RXSTART.indicate (RXVECTOR)	0 - RSSI Max
DATARATE	PHY-RXSTART.request (RXVECTOR)	20.9677 Mbit/s, 25.0000 Mbit/s, 41.9355 Mbit/s, 50.0000 Mbit/s, 62.9032 Mbit/s, 75.0000 Mbit/s, 83.8710 Mbit/s, 100.0000 Mbit/s

Table 29, RXVECTOR Parameters

1.2.3.1 RXVECTOR LENGTH

SAME

1.2.3.2 RXVECTOR RSSI

SAME

1.3 OQM Physical Layer Convergence Procedure Sublayer

1.3.1 Introduction

This subclause provides a convergence procedure to map MAC PDUs into a frame format designed for OQM radio transceivers. The procedures for transmission, carrier sense, and reception are defined for single and multiple antenna diversity radios.

1.3.1.1 State Diagram Notation

SAME

1.3.2 Error Correcting Coding (ECC)

The OQM physical layer employs Error Correction Coding (ECC) to improve robustness with respect to channel and implementation impairments. The ECC uses single error correcting (31,26,3) Hamming code which may be shortened to $(n=k+5,k,3)$ code, with $0 \leq k \leq 26$, as to accommodate short frames, such as PLCP header or the last data frame. The Hamming ECC is used in conjunction with interleaving to improve robustness with respect to bursts of errors which are typical to reception of transmissions inflicted by multipath. The interleaving maintains a separation in time for bits belonging to same ECC block.

1.3.2.1 Shortened Hamming Error Correcting Code

The single error correcting (31,26,3) Hamming code with generator polynomial $g(x)=x^5+x^2+1$ is encoded with the following scheme:

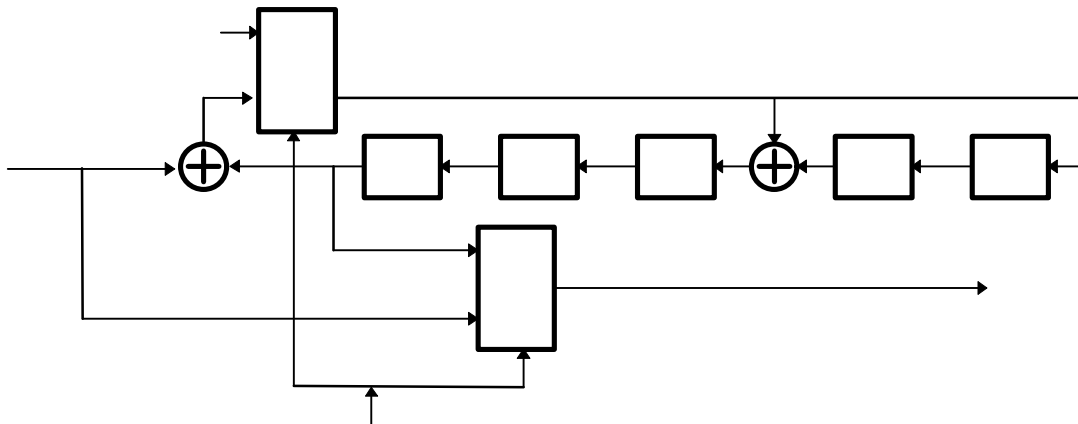

Figure 72, Hamming encoder structure

The encoding process can be described by the pseudocode in Table xxxx

```

/*      The subroutine outputs a bit to be transmitted. The input parameters are:      */
/*      n = number of bits in an ECC block, including check bits, 5<=n<=31          */
/*      j = number of a data bit within a block, 1<=j<=31                          */
/*      encoder is an entity containing the encoder's state                          */
BIT GetEncodedBit(j, n, encoder) {
if ECCused then Ncheck=5 else Ncheck=0;
/* Ncheck=5 for a shortened (31,26,3) Hamming code */
if j=1 then reset state of encoder's register to "all zeroes";

```

```

if j<(n-Ncheck) then { Set selector to "Input Bit"; Get data bit from input; }
    else { Set selector to "Check Bit";}
Update encoder's state machine;
return input data bit or check bit, according to selector state; }
    
```

Figure 77, Shortened Hamming Code Encoding Procedure

The decoding of a single error correcting (31,26,3) Hamming code with generator polynomial $g(x)=x^5+x^2+1$ is performed with the following scheme:

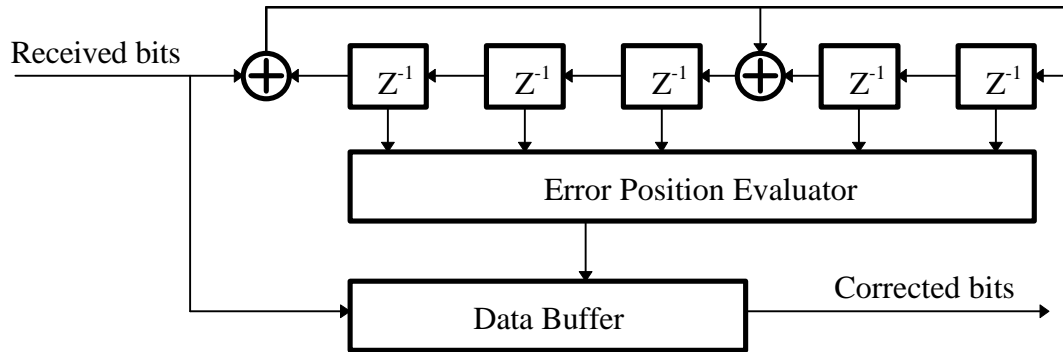

Figure 72, Hamming decoder structure

The decoding process can be described by the pseudocode in Table xxxx

```

/*      The first of the two following subroutines processes received bits and corrects them      */
/*      The input parameters are:                                                                */
/*      n = number of bits in an ECC block, including check bits, 5<=n<=31                       */
/*      j = number of a data bit within a block, 1<=j<=31                                       */
/*      decoder is an entity containing the decoder's state and data buffer contents             */
ProcessReceivedBit(j, n, decoder, RxBit) {
if j=1 then reset state of decoder's register to "all zeroes";
if ECCused then Ncheck=5 else Ncheck=0;
Update state machine using RxBit;
if j<(n-Ncode) then { Save RxBit in data buffer; }
if ECCused and (j=n) and (state of decoder's register is not "all zeroes") then
    {
    evaluate position of error;
    if the erroneous bit is in data buffer then invert it;
    }
}

/*      The second subroutine delivers the corrected bits when requested                          */
BIT GetCorrectedBit(j,n, decoder) {
return bit j from the decoder's data buffer
}
    
```

Figure 77, Shortened Hamming Code Decoding Procedure

1.3.2.2 Interleaver for the shortened Hamming ECC

The operation of the interleaver is demonstrated by Figure xxxxx. Consecutive data bits being transmitted are being taken each from next encoder, in a circular manner. Correspondingly, each time another encoder demands a bit from the input. As a result, bits belonging to same ECC block are transmitted at distance of at least D bits from each other. The parameter D is called "interleaving depth". On the receive

side an opposite operation takes place: The consecutive received bits are transferred each to next decoder. After all bits belonging to same ECC block are fed to all the decoders, the corrected bits are read out, consecutive bits read each from next decoder.

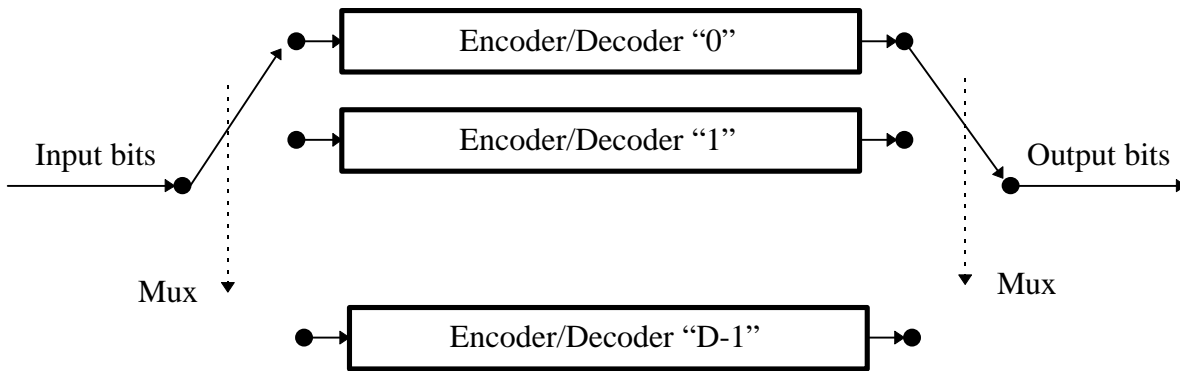

Figure 72, Interleaver/Deinterleaver structure

The interleaver utilizes the (31,26,3) ECC with 26 bit block size as long as there are enough bits to fill a whole block for all the encoders. In last frame the capability of the ECC to shorten the block size is utilized to avoid sending ECC blocks in which not all bits are utilized.

Same capability to use block size only to the extent required by the amount of data is utilized in order to encode the PLCP header which contains 40 data bits.

The interleaving depth shall be:

$D=8$ for the PLCP header

$D=8 \times \text{BitsPerSymbol}$ for the PLCP_PDU (i.e. 8 symbol interleaving depth)

The interleaving process can be described by the pseudocode in Table xxxx

```

/* The subroutine performs an interleaving of a single frame. The input parameters are: */
/* N = number of data bits to be encoded and interleaved,  $N \leq D \times N_{data}$  */
/* D = interleaving depth.  $D = 8 \times \text{BitsPerSymbol}$  */
InterleaveOneFrame(N,D) {
/* an array of D encoders is used */
If ECCused then Ncheck=5 else Ncheck=0;
for j=0 to N-1+D*Ncheck { /* Ncheck=5 for a shortened (31,26,3) Hamming code */
    GetEncodedBit(1+j/D, ((N-1-(j mod D))/D+1+Ncheck, encoder[j mod D]);
}
}

InterleavePacket(Length, BitsPerSymbol) {
ECCused = true; /* PLCP header always uses ECC */
InterleaveOneFrame(40, 8); /* PLCP header is encoded in a separate interleaver/ECC frame */
BitsRemaining = Length*8; /* convert octets to bits */
D=8*BitsPerSymbol;

```



```

set ECCused according to what appears in PLCP header;
while (BitsRemaining> Ndata*D) {
    InterleaveOneFrame(D*Ndata, D); /* full frames of length D*Ndata */
    BitsRemaining = BitsRemaining- D*Ndata;
}
InterleaveOneFrame(BitsRemaining, D); /* last frame, probably shorter than D*Ndata */
}

```

Figure 77, Interleaving and ECC Encoding Procedures

The deinterleaving and decoding process can be described by the pseudocode in Table xxxx

```

/*      The subroutine performs an interleaving of a single frame. The input parameters are:      */
/*      N = number of data bits to be encoded and interleaved, N<=D*Ndata                      */
/*      D = interleaving depth. D=8*BitsPerSymbol                                           */
DeinterleaveOneFrame(N,D) {
/* an array of D decoders is used */
If ECCused then Ncheck=5 else Ncheck=0;
for j=0 to N-1+D*Ncheck {
    ProcessReceivedBit(1+j/D, ((N-1-(j mod D))/D+1+Ncheck, decoder[j mod D]);
}
/* At this stage all the bits belonging to the ECC blocks are received and corrected */
for j=0 to N-1 { /* Extract corrected bits */
    GetCorrectedBit(1+j/D, ((N-1-(j mod D))/D+1+Ncheck, decoder[j mod D]);
}
}

DeinterleavePacket {
Ncheck=5; ECCused=true ; /* ECC is always used for PLCP header */
DeinterleaveOneFrame(40, 8); /* PLCP header is encoded in a separate interleaver/ECC frame */
Check CRC16 of the PLCP header;
Extract from header Length, BitsPerSymbol and ECCused;
BitsRemaining = Length*8; /* convert octets to bits */
D=8*BitsPerSymbol;
while (BitsRemaining> Ndata*D) {
    InterleaveOneFrame(D*Ndata, D); /* full frames of length D*Ndata */
    BitsRemaining = BitsRemaining- D*Ndata;
}
InterleaveOneFrame(BitsRemaining, D); /* last frame, probably shorter than D*Ndata */
}

```

Figure 77, Deinterleaving and ECC Decoding Procedures

The pseudocode treats uniformly for clarity reasons the cases ECC is used or not used. In practice, in the uncoded case the interleaver retains the data in its original order and there is no need to buffer the data in the decoders prior to delivering it out.

Example: A packet of 73 octets needs to be transmitted at 2 bits/symbol.

Interleaver frame 1: PLCP header, 40 bit long, is split into 8 groups of 5 bits; each group is encoded by (10,5,3) code, resulting in an encoded frame 80 bits long. The header is transmitted at 1 bit/symbol, therefore the transmission is 80 symbol long.

Interleaver frame 2: first $16 \times 26 = 416$ bits of PLCP_PDU. Each 26 bits are encoded into 31 bits by the (31,26,3) Hamming code, resulting in $16 \times 31 = 496$ encoded bits. The 496 bits are transmitted at 2 bits/symbol, therefore the transmission is 248 symbol long.

Interleaver frame 3: rest 21 octets are divided by the interleaver into 16 groups, first 8 having 11 bits each, and the last 8 having 10 bits each, $21 \cdot 8 = (8 \cdot 11) + (8 \cdot 10) = 168$ bits. The bits of the first group are encoded by (11,16,3) shortened Hamming code, while the bits of the second group are encoded by the (10,15,3) shortened Hamming code. The resulting message length is $(8 \cdot 16) + (8 \cdot 15) = 248$ bits, or 124 symbols at 2 bits/symbol.

1.3.3 Physical Layer Convergence Procedure Frame Format

The PLCP Frame Format provides for the asynchronous transfer of MAC sublayer MPDUs from any transmitting station to all receiving stations within the wireless LAN's BSS. The PLCP frame format illustrated in Figure 72 consists of three parts: a PLCP Preamble, a PLCP Header, and a PLCPPDU. The PLCP Preamble provides a period of time for several receiver functions. These functions include resolving antenna diversity, acquisition of symbol and carrier tracking, and field delineation of the PLCP Header and the PLCPPDU. The PLCP Header is used to specify the length of the MPDU field and support any PLCP management information. The PLCP header is protected by an Error Correcting Code. The PLCPPDU contains the MPDU data modified by the PLCPPDU data scrambler and optionally protected by an Error Correcting Code.

Figure 72, PLCP Frame Format

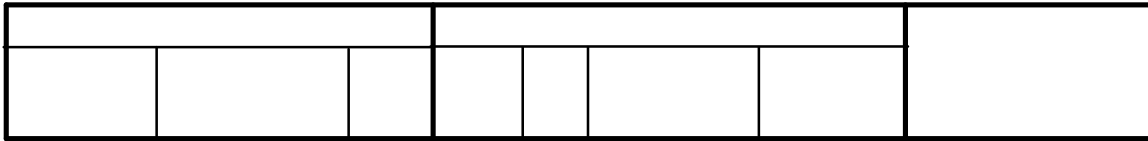

1.3.3.1 PLCP Preamble

The PLCP preamble is a 256 bit long sequence composed of 8 segments, each 32 bits long. The sequence can be written as

$$-B_{32} -B_{32} -B_{32} A_{32} B_{32} A_{32} -B_{32} A_{32}$$

where minus denotes logic inversion and A_{32} and B_{32} are Golay complementary sequences:

$$A_{32} = 1110\ 1101\ 1110\ 0010\ 1110\ 1101\ 0001\ 1101$$

$$B_{32} = 1110\ 1101\ 1110\ 0010\ 0001\ 0010\ 1110\ 0010$$

The PLCP preamble sequence can be logically viewed as composed of three separate sub-fields: sync field ($-B_{32} -B_{32} -B_{32}$), start frame delimiter ($A_{32} B_{32} A_{32} -B_{32}$) and tail (A_{32}). The PLCP Preamble allows the PHY circuitry to achieve synchronization of the symbol clock and of the frame start, to acquire carrier phase and to estimate the propagation channel for the purpose of performing equalization in the receiver, if desired.

1.3.3.1.1 Sync

The preamble sync field is an 96-bit field containing three repetitions of $-B_{32}$ sequence, to be used by the PHY sublayer to detect a potentially-receivable signal, select an antenna if diversity is utilized, and reach initial frequency offset correction and synchronization with the received packet timing.

1.3.3.1.2 Start Frame Delimiter

The start frame delimiter (SFD) consists of the 128-bit binary pattern ($A_{32} B_{32} A_{32} -B_{32}$). The first bit of the start frame delimiter follows the last bit of the sync pattern. The start frame delimiter defines the frame timing. In addition, it facilitates refinement of the carrier frequency and phase estimate and also the estimation of the channel transfer function.

1.3.3.1.3 Tail

The tail of the PLCP Preamble consists of the 32-bit binary pattern (A_{32}). The first bit of the tail follows the last bit of the SFD pattern. The purpose of the tail is to create a circular continuation of the SFD and to assure by this better correlation properties which are essential to accurate estimation of the channel transfer function.

1.3.3.2 PLCP Header

The PLCP Header field contains three separate sub-fields: a 12-bit PLCP PDU Length Word (PLW), a 4-bit PLCP Signaling Field (PSF) and a 16-bit PLCP Header Error Check (HEC) field.

1.3.3.2.1 PLCP PDU Length Word

The PLCP PDU Length Word (PLW) is passed from the MAC as a parameter within the PHY-TXSTART.request primitive. The PLW specifies the number of data octets contained in the MPDU packet, not including the ECC overhead. Its valid values are 001h - FFFh, representing counts of one to 4095 octets. The PLW is transmitted lsb first and msb last. The PLW is used by the receiving station, in combination with the rate and ECC method derived from the PSF, to determine the last bit in the packet.

1.3.3.2.2 PLCP Signaling Field

The 4-bit PLCP Signaling Field (PSF) is defined in Table 30, PLCP Signaling Field Bit Descriptions. The PSF is transmitted bit 0 first and bit 3 last.

Bit	Parameter Name	Parameter Values	Description																																																		
3:0	PLCP_BITRATE	<table border="0"> <tr> <td>b3</td> <td>b2</td> <td>b1</td> <td>b0</td> <td>Data Rate</td> </tr> <tr> <td>0</td> <td>0</td> <td>0</td> <td>0</td> <td>= 20.9677 Mbit/s,</td> </tr> <tr> <td>0</td> <td>1</td> <td>0</td> <td>0</td> <td>= 25.0000 Mbit/s,</td> </tr> <tr> <td>0</td> <td>0</td> <td>0</td> <td>1</td> <td>= 41.9355 Mbit/s,</td> </tr> <tr> <td>0</td> <td>1</td> <td>0</td> <td>1</td> <td>= 50.0000 Mbit/s,</td> </tr> <tr> <td>0</td> <td>0</td> <td>1</td> <td>0</td> <td>= 62.9032 Mbit/s,</td> </tr> <tr> <td>0</td> <td>1</td> <td>1</td> <td>0</td> <td>= 75.0000 Mbit/s,</td> </tr> <tr> <td>0</td> <td>0</td> <td>1</td> <td>1</td> <td>= 83.8710 Mbit/s,</td> </tr> <tr> <td>0</td> <td>1</td> <td>1</td> <td>1</td> <td>= 100.0000 Mbit/s,</td> </tr> <tr> <td>1</td> <td>x</td> <td>x</td> <td>x</td> <td>= reserved</td> </tr> </table>	b3	b2	b1	b0	Data Rate	0	0	0	0	= 20.9677 Mbit/s,	0	1	0	0	= 25.0000 Mbit/s,	0	0	0	1	= 41.9355 Mbit/s,	0	1	0	1	= 50.0000 Mbit/s,	0	0	1	0	= 62.9032 Mbit/s,	0	1	1	0	= 75.0000 Mbit/s,	0	0	1	1	= 83.8710 Mbit/s,	0	1	1	1	= 100.0000 Mbit/s,	1	x	x	x	= reserved	<p>The b1-b0 subfield is related to the number of bits per symbol.</p> <p>The b2-b3 subfield is related to the Error Correction Coding method employed. Currently only values 0 (Hamming with 8 symbol interleaving) and 1 (no ECC) are supported.</p>
b3	b2	b1	b0	Data Rate																																																	
0	0	0	0	= 20.9677 Mbit/s,																																																	
0	1	0	0	= 25.0000 Mbit/s,																																																	
0	0	0	1	= 41.9355 Mbit/s,																																																	
0	1	0	1	= 50.0000 Mbit/s,																																																	
0	0	1	0	= 62.9032 Mbit/s,																																																	
0	1	1	0	= 75.0000 Mbit/s,																																																	
0	0	1	1	= 83.8710 Mbit/s,																																																	
0	1	1	1	= 100.0000 Mbit/s,																																																	
1	x	x	x	= reserved																																																	

Table 30, PLCP Signaling Field Bit Descriptions

1.3.3.2.3 PLCP Header Reserved Field

The PLCP header reserved field is an 8 bit field reserved for future use. This field will be set to value 00h.

1.3.3.2.4 Header Error Check Field

SAME

1.3.3.2.5 PLCP Header ECC check bits

The PLCP Header shall be protected by the shortened Hamming ECC with interleaving depth 8, as described in clause xxxxxxx. As a result, a total of 40 check bits will be generated and appended to the PLCL header. Following the PLCP header, the ECC mechanism shall be reset to a state of “Start of Block”.

1.3.3.3 PLCPPDU Data Scrambler

The PLCPPDU data whitener uses a length-127 frame-synchronous scrambler. Data octets are placed in the transmit serial bit stream lsb first and msb last. The frame synchronous scrambler uses the generator polynomial S(x) as follows:

$$S(x) = x^7 + x^4 + 1$$

and is illustrated in Figure 73. The 127-bit sequence generated repeatedly by the scrambler is (leftmost used first) 00001110 11110010 11001001 00000010 00100110 00101110 10110110 00001100 11010100 11100111 10110100 00101010 11111010 01010001 10111000 11111111. The same scrambler is used to scramble transmit data and to descramble receive data..

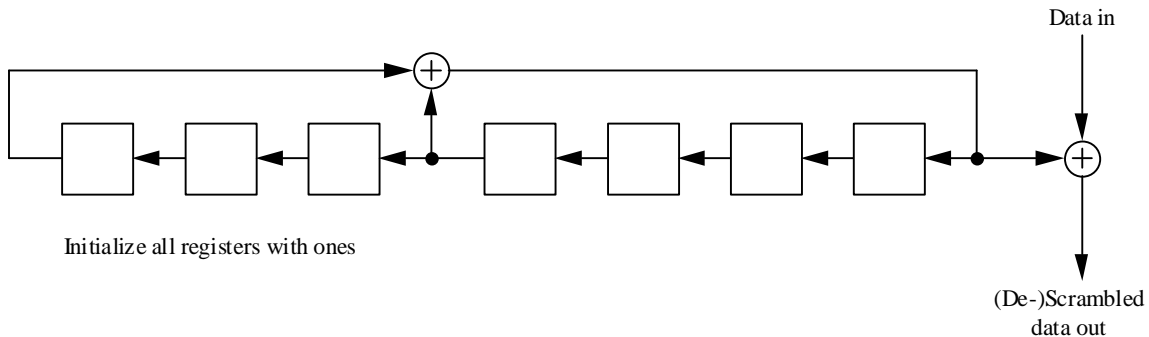

Figure 73, Frame Synchronous Scrambler/Descrambler

1.3.4 PLCP State Machines

SAME

1.3.4.1 PLCP Transmit Procedure

The PLCP transmit procedure is invoked by the CS/CCA procedure immediately upon receiving a *PHY-TXSTART.request(TXVECTOR)* from the MAC sublayer. The CSMA/CA protocol is performed by the MAC with the PHY PLCP in the CS/CCA procedure prior to executing the transmit procedure.

1.3.4.1.1 Transmit State Machine

The PLCP transmit state machine illustrated in Figure 76 includes functions that must be performed prior to, during, and after MPDU data transmission. Upon entering the transmit procedure in response to a *PHY-TXSTART.request (TXVECTOR)* from the MAC, the PLCP shall switch the PHY PMD circuitry from receive to transmit state; ramp on the transmit power amplifier in the manner prescribed in 14.6 (PMD specification); and transmit the preamble sync pattern, with differential precoding in the PMD turned off. After the preamble sync pattern the differential precoding shall be turned on and remain so until the end

of the packet. The PLCP shall generate the PLCP header as defined in 14.3.2.2 (PLCP Header) in sufficient time to send the bits at their designated bit slot time. The PLCP shall add the PLCP header to the start of the PLCPDU data.

Prior to transmitting the first MPDU data bit, the PLCP shall send a *PHY-TXSTART.confirm* message to the MAC indicating that the PLCP is ready to receive an MPDU data octet. The MAC will pass an MPDU data octet to the PHY with a *PHY-DATA.request(DATA)* which the PHY will respond to with a *PHY-DATA.confirm*. This sequence of *PHY-DATA.request(DATA)* and *PHY-DATA.confirm* shall be executed until the last data octet is passed to the PLCP. During transmission of the PLCPDU data, each bit of the MPDU passed from the MAC shall be processed by the data scrambler algorithm defined in Figure xxxxx and described in 14.3.2.3 (PLCPDU Data Scrambler). Each MPDU data octet is processed and transmitted lsb first and msb last. After scrambling, the data bits are processed by the Interleaving/ECC encoding algorithm. The resulting bit stream is divided into groups of bits (symbols), according to the rate chosen, and the symbols are submitted to the PHY PMD for imposing the symbols onto the airwaves.

After the last MPDU octet is passed to the PLCP, the MAC will indicate the end of the frame with a *PHY-TXEND.request*. After the last bit of the PLCPDU data has completed propagation through the radio and been transmitted into the air, the PLCP shall complete the transmit procedure by sending a *PHY-TXEND.confirm* to the MAC sublayer, ramp off the power amplifier in the manner prescribed in subclause 14.6 (PMD), and switch the PHY PMD circuitry from transmit to receive state. The execution shall then return to the CS/CCA procedure.

Figure 76, Transmit State Machine

1.3.4.1.2 Transmit State Timing

The transmit timing illustrated in Figure 78 is defined from the instant that the *PHY-TXSTART.request(TXVECTOR)* is received from the MAC sublayer. The PLCP shall switch the PMD circuitry from receive to transmit, turn on and settle the transmitter, and begin transmitting the first bit of the preamble at the antenna within a maximum of 20 μ s of receiving the *PHY-TXSTART.request(TXVECTOR)*. The PLCP preamble shall be transmitted at 1 Mbit/s and be completed in 96 μ s. The PLCP header shall be transmitted at 1 Mbit/s and be completed in 32 μ s. The variable length PLCPDU shall be transmitted at the selected data rate. After the last bit of the PLCPDU data has completed propagation through the radio and been transmitted onto the air, the PLCP shall send the *PHY-TXEND.confirm* to the MAC sublayer. The PLCP shall turn off the transmitter, reducing the output energy to less than the specified off-mode transmit power within the time specified in subclause 14.6. At the end of the power amplifier ramp down period, the PLCP shall switch the PMD circuitry from transmit to receive.

Figure 78, Transmit State Timing

1.3.4.2 Carrier Sense/Clear Channel Assessment Procedure

The PLCP carrier sense/clear channel assessment (CS/CCA) procedure is executed while the receiver is turned on and the station is not currently receiving or transmitting a packet. The CS/CCA procedure is used for two purposes: to detect the start of a network signal that can be received (CS) and to determine whether the channel is clear prior to transmitting a packet (CCA).

1.3.4.2.1 Carrier Sense/Clear Channel Assessment State Machine

Timing for priority (PIFS, DIFS), contention backoff (slot times), and CS/CCA assessment windows are defined relative to the end of the last bit of the last packet on the air. The carrier sense/clear channel assessment (CS/CCA) state machine is shown in Figure 79. The PLCP shall perform a CS/CCA assessment on a minimum of one antenna within a MAC contention backoff slot time of 6.0 μ s. The PLCP shall be capable of detecting within the slot time an OQM PHY conformant signal which is received at the selected antenna up to 1.5 μ s after the start of the slot time with the synchronous detection performance specified in 14.6.15.3. 14.6.15.3 specifies detection performance with zero-one sync patterns and with random data patterns. If a start of a transmission is asynchronous with the BSS and arrives after the start of the slot but at least 3.0 μ s prior to the end of the slot, the PLCP shall indicate a busy channel prior to the end of the slot time with the asynchronous detection performance specified in 14.6.15.3. The CCA indication immediately prior to transmission shall be performed on an antenna with essentially the same free space gain and gain pattern as the antenna to be used for transmission. The method of determining CS/CCA is unspecified except for the detection performance of a conformant method as specified in 14.6.15.3.

If a *PHY-TXSTART.request (TXVECTOR)* is received, the CS/CCA procedure shall exit to the transmit procedure within 1 μ s. If a *PHY-CCARESET.request* is received, the PLCP shall reset the CS/CCA state machine to the state appropriate for the end of a complete received frame. This service primitive is generated by the MAC at the end of a NAV period. The PHY shall indicate completion of the request by sending a *PHY-CCARESET.confirm* to the MAC.

If a CS/CCA assessment returns a channel idle result, the PHY shall send a *PHY-CCA.indicate(STATUS=idle)* to the MAC.

If a CS/CCA assessment returns a channel busy result, the PHY shall send a *PHY-CCA.indicate(STATUS=busy)* to the MAC. Upon a channel busy assessment, the PLCP shall stop any antenna switching prior to the earliest possible arrival time of the start frame delimiter (SFD) and detect a valid SFD and PLCP header if received. A valid PLCP header is defined as containing valid PLCP Length Word and PHY Signaling Field values and a valid Header Error Check field. If a valid SFD/PLCP header is detected, the CS/CCA procedure shall send a *PHY-RXSTART.indicate(RXVECTOR)* message to the MAC sublayer and exit to the receive procedure. The PLCP shall dwell and search for the SFD/PLCP header for a minimum period longer than the latest possible arrival time of the SFD/PLCP header. Indication of a busy channel does not necessarily lead to the successful reception of a frame.

The octet/bit count remaining may be a non-zero value when returning from the receive procedure if a signal in the process of being received was lost prior to the end as determined from the length field of a valid PLCP header. The countdown timer shall be set to the octet/bit count and used to force the CS/CCA indication to remain in the BUSY state until the predicted end of the frame regardless of actual CS/CCA indications.

However, if the CS/CCA procedure indicates the start of a new frame within the countdown timer period, it is possible to transition to the receive procedure prior to the end of the countdown timer period. If the PHY transitions to receive under these conditions, the countdown timer shall be reset to the longer of (1) the remaining time of the current frame and (2) the length of the new frame.

When a non-zero countdown timer reaches zero, the PLCP shall reset the CS/CCA state machine to the state appropriate for the end of a complete received frame and the CS/CCA indication shall reflect the state of the channel.

If the receive procedure encountered an unsupported rate error, the PLCP shall keep the CS/CCA state at Busy for the duration of the frame by setting the countdown timer to the value corresponding to the calculated time based on the length and rate information in the PLCP header.

Figure 79, CS/CCA State Machine

1.3.4.2.2 Carrier Sense/Clear Channel Assessment State Timing

Timing for priority (PIFS, DIFS), contention backoff (slot times), and CS/CCA assessment windows are defined relative to the end of the last bit of the last packet on the air. The PLCP shall perform a CS/CCA assessment on a minimum of one antenna within a slot time. The appropriate CS/CCA indication shall be available prior to the end of each 6.0 μ s slot time with the performance specified in subclause 14.6 (PMD).

If a station has not successfully received the previous packet, the perceived packet end time and slot boundary times will have a higher uncertainty for that station.

Figure 80, CS/CCA State Timing

1.3.4.3 PLCP Receive Procedure

The PLCP receive procedure is invoked by the PLCP carrier sense/clear channel assessment (CS/CCA) procedure upon detecting a portion of the preamble sync pattern followed by a valid start frame delimiter and PLCP header.

1.3.4.3.1 Receive State Machine

The PLCP receive procedure shown in Figure 81 includes functions that must be performed while receiving the PLCPDU data. The PLCP receive procedure begins upon detection of a valid start frame delimiter and PLCP header in the CS/CCA procedure. The PLCP shall set a PLCPDU octet/bit counter to indicate the last bit of the packet, receive the PLCPDU symbols, convert those into bits, and perform the Deinterleaving/ECC decoding on each PLCPDU bit. The PLCP shall pass correctly received data octets to the MAC with a series of *PHY-DATA.indicate(DATA)*. After the last PLCPDU bit is received and the last octet is passed to the MAC, the PLCP shall send a *PHY-RXEND.indicate(RXERROR=no_error)* to the MAC sublayer. Upon error-free completion of a packet reception, the PLCP shall exit the receive procedure and return to the PLCP CS/CCA procedure with the octet/bit count set to 0.

If the PLCP header was decoded without a CRC error but encountered an unsupported rate, then the PLCP shall immediately complete the receive procedure with a *PHY-RXEND.indicate(RXERROR = unsupported_rate)* to the MAC, and return to the CS/CCA procedure with the octet/bit count remaining and the data rate value contained in the PLCP header.

If an error was detected during the reception of the packet PLCPDU, the PLCP shall immediately complete the receive procedure with a *PHY-RXEND.indicate(RXERROR=carrier_lost)* to the MAC, and return to the CS/CCA procedure with the octet/bit count remaining and the data rate value contained in the PLCP header.

Figure 81, Receive State Machine

1.3.4.3.2 Receive State Timing

The receive state timing shown in Figure 83 is defined to begin upon detection of a valid start frame delimiter and PLCP header in the CS/CCA procedure. The PLCP shall begin receiving the variable length PLCPDU immediately after the end of the last bit of the PLCP header. The PLCP shall send a *PHY-RXEND.indicate(RXERROR)* after receiving the last PLCPDU data bit.

If any error was detected during the reception of the PLCPDU, the PLCP may send a *PHY-RXEND.indicate(RXERROR)* and terminate the receive procedure before the last bit arrives.

Figure 83, Receive Timing

1.4 PLME SAP Layer Management.

1.4.1 Introduction

This subclause describes the services provided by the OQM PLME to the upper layer management entities. The PLME/PMD services are defined in terms of service primitives. These primitives are abstract representations of the services and are not intended to restrict implementations.

1.4.2 OQM PHY Specific MAC Sublayer Management Entity Procedures

1.4.2.1 Introduction

This portion of this subclause identifies the specific MAC subLayer Management Entity procedures (MLME) required for operating the OQM PHY. The relationship between the MLME and OQM PLME procedures are also described.

1.4.2.2 Frequency Hopping Synchronization

The MLME of a compliant OQM PHY station shall perform the frequency hopping time synchronization procedure as defined in 11.1.5. This procedure provides for synchronized frequency hopping for all compliant OQM PHY stations within a single BSS or ad hoc network. The OQM PLME accepts PLME-SET.request commands from the MLME to change the tune frequency at the time determined by the MLME. The tune frequency is changed by updating any combination of the Set, Pattern, and Index PHY MIB parameters.

1.4.3 OQM PHY Layer Management Entity State Machines

1.4.3.1 Introduction

This portion of this subclause describes the OQM PHY Layer Management state machines to turn the PMD on/off, reset the PLCP state machine, and change the frequency hop channel.

1.4.3.2 PLME State Machine

SAME (with TBD changes regarding hopping?)

1.4.3.3 PLME Management Primitives

The OQM PLME uses the generic management primitives defined in clause **Error! Reference source not found.** to manage all OQM PHY parameters.

1.5 OQM Physical Medium Dependent Sublayer Services

1.5.1 Scope and Field of Application

SAME

1.5.2 Overview of Services

SAME

1.5.3 Overview of Interactions

SAME

1.5.4 Basic Service and Options

SAME

1.5.4.1 PMD_SAP Peer-to-Peer Service Primitives

SAME

1.5.4.2 PMD_SAP Sublayer-to-Sublayer Service Primitives

SAME

1.5.4.3 PMD_SAP Service Primitives Parameters

The following table shows the parameters used by one or more of the PMD_SAP Service Primitives.

Parameter	Associate Primitive	Value
TXD_UNIT	PMD_DATA.request	1 bit/symbol: 0, 1 2 bits/symbol: 0, 1, 2, 3 3 bits/symbol: 0, 1, 2, ... , 7 4 bits/symbol: 0, 1, 2, ... , 15
RXD_UNIT	PMD_DATA.indicate	1 bit/symbol: 0, 1 2 bits/symbol: 0, 1, 2, 3 3 bits/symbol: 0, 1, 2, ... , 7 4 bits/symbol: 0, 1, 2, ... , 15
RF_STATE	PMD_TXRX.request	TRANSMIT, RECEIVE
RAMP_STATE	PMD_PA_RAMP.request	ON, OFF
ANTENNA_STATE	PMD_ANTSEL.request	1 to 255
TXPWR_LEVEL	PMD_TXPWRLVL.request	LEVEL1, LEVEL2, LEVEL3, LEVEL 4
CHNL_ID	PMD_FREQ.request	1 through 39 inclusive
STRENGTH	PMD_RSSI.indicate	0 - RSSI Max
MODE	PMD_PWRMGMT.request	ON, OFF

Table 34, List of Parameters for PMD Primitives

1.5.5 PMD_SAP Detailed Service Specification

This subclause describes the services provided by each PMD primitive.

1.5.5.1 PMD_DATA.request

Function. This primitive defines the transfer of data from the PLCP sublayer to the PMD entity.

Semantics of the Service Primitive. The primitive shall provide the following parameters:

PMD_DATA.request (TXD_UNIT)

The TXD_UNIT parameter can take a value in a set dependent on a number of bits/symbol. This parameter represents a data to be imposed onto a single symbol. The effect of this parameter is that the PMD will properly modulate the medium to represent the symbol values as defined in the OQM PMD Modulation Specifications for a given data rate.

When Generated. This primitive is generated by the PLCP sublayer to request the transmission of a single data symbol on the Physical Medium Dependent sublayer. The symbol clock is assumed to be resident or part of the PLCP and this primitive is issued at every clock edge once the PLCP has begun transmitting data.

Effect of Receipt. The receipt of this primitive will cause the PMD entity to encode and transmit a single data symbol.

1.5.5.2 PMD_DATA.indicate

Function. This primitive defines the transfer of data from the PMD entity to the PLCP sublayer.

Semantics of the Service Primitive. The primitive shall provide the following parameters:

PMD_DATA.indicate (RXD_UNIT)

The RXD_UNIT parameter can take a value in a set dependent on a number of bits/symbol. This value represents a data extracted from a single symbol as defined in the OQM PMD Modulation Specifications for a given data rate.

When Generated. The PMD_DATA.indicate is generate to all receiving PLCP entities in the network after a PMD_DATA.request is issued.

Effect of Receipt. The effect of receipt of this primitive by the PLCP is unspecified.

1.5.5.3 PMD_TXRX.request

SAME

1.5.5.4 PMD_PA_RAMP.request

SAME

1.5.5.5 PMD_ANTSEL.request

SAME

1.5.5.6 PMD_TXPWRLVL.request

SAME

1.5.5.7 PMD_FREQ.request

SAME

1.5.5.8 PMD_RSSI.indicate

SAME

1.5.5.9 PMD_PWRMGMT.request

SAME

1.6 25 Msymbol/s OQM Physical Medium Dependent Sublayer

1.6.1 OQM PMD Operating Specifications General

In general, the PMD accepts Convergence Layer-service primitives and provides the actual means by which the signals required by these primitives are imposed onto the medium. In the Physical Medium Dependent sublayer at the receiver the process is reversed. The combined function of the transmitting and receiving Physical Medium Dependent sublayers results in a data stream, timing information, and receive parameter information being delivered to the receiving Convergence Sublayer.

1.6.2 Regulatory Requirements

SAME introduction

North America:

Federal Communications Commission (FCC), USA
Documents: CFR47, Part 15, Sections 15.4xx.

Approval Authority: FCC (USA)

1.6.3 Operating Frequency Range

A conformant PMD implementation shall be able to select the carrier frequency (F_c) from the full geographic-specific set of available carrier frequencies. Table 36 summarizes these frequencies for a number of geographic locations:

Lower Limit	Upper Limit	Regulatory Range	Geography
5.175 GHz	5.325 GHz	5.15-5.35 GHz	North America*, lower
5.750 GHz	5.800 GHz	5.725-5.825 GHz	North America*, upper

Table 36, Operating Frequency Range

* The frequency ranges in this table are subject to the geographic specific regulatory authorities

1.6.4 Number of Operating Channels

The hopping capability is optional, details TBD.

1.6.5 Operating Channel Center Frequency

The channel center frequencies are defined in sequential 25.0 MHz steps, with channel number "0" corresponding to frequency 5.000 GHz. The channel centers for the North America lower band are listed in Table 38. The channel centers for the North America upper band are listed in Table 39.

Channel #	Value	Power limits in US
7	5.175	Low power
8	5.200	Low power
9	5.225	Low power
10	5.250	Low power
11	5.275	High power
12	5.300	High power
13	5.325	High power

Table 38, North American lower band Requirements

(Values specified in GHz)

Channel #	Value	Power limits in US
30	5.750	Very High power
31	5.775	Very High power
32	5.800	Very High power

Table 39, North American upper band Requirements

(Values specified in GHz)

1.6.6 Occupied Channel Bandwidth

Occupied channel bandwidth shall meet all applicable local geographic regulations for 25.0 MHz channel spacing. The rate at which the PMD entity will hop at is governed by the MAC. The hop rate is an attribute with a maximum dwell time subject to local geographic regulations.

1.6.7 Hop Sequences

TBD

1.6.8 Unwanted Emissions

Conformant PMD implementations of this OQM standard shall limit the emissions that fall outside of the operating frequency range, defined in Table 36 of 14.6.3, to the geographically applicable limits.

1.6.9 Modulation

The minimum set of requirements for a PMD to be compliant with the 802.11 OQM PHY shall be as follows.

1.6.9.1 Differential Precoding and Symbol-to-Amplitude Mapping

The PMD shall accept from the PLCP at each symbol interval a tuple consisting of a number of bits per symbol (in the range 1 to 4), differential precoding flag (true or false) and a symbol value (in the range 0 to 1 up to 0 to 15, depending on number of bits per symbol). The PMD shall convert the incoming symbol values into amplitude levels by first differentially precoding the MSB of the symbol value (if flag is true) and then converting the resulting symbol value to an amplitude level according the Table 47 below. The tables follow the Gray encoding rule for minimizing the bit error to symbol error ratio in a receiver.

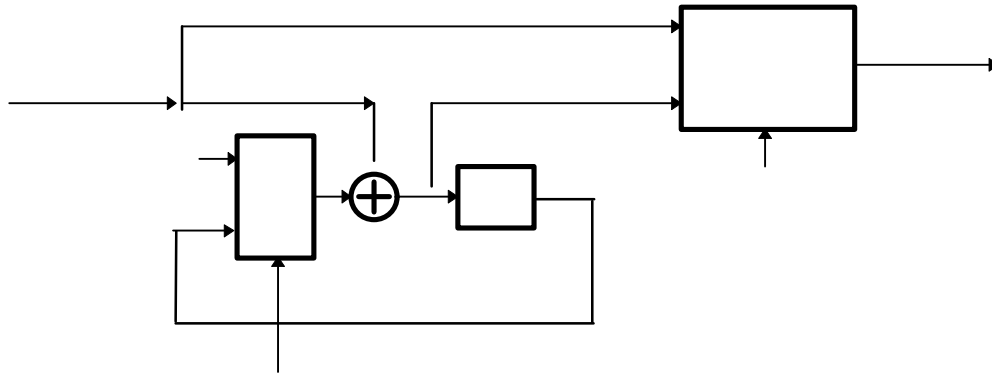

Figure 72, Differential Encoder and Symbol-to-Amplitude Mapping structure

1.6.9.2 Offset Quadrature Modulation

The resulting symbol stream shall be nominally modulated onto a carrier frequency as

$$s(t) = \sum_{k=1}^N a_k \exp(j\rho k / 2) p(t - kT_s)$$

where

a_k is the k-th real-valued symbol

T_s is symbol period (bit period for binary signaling), nominally 40 nsec.

$p(t)$ is the transmit pulse shape.

The complex exponent rotates by 90 degrees between consecutive symbols creating thus the effect that even-numbered symbols modulate the in-phase component, while the odd-numbered symbols modulate the quadrature component of the carrier, as Offset Quadrature modulation requires.

The transmit pulse shape shall nominally be a convolution of half-sine waveform with a Gaussian:

$$p_{MSK}(t) = \sin(\rho t / 2T_s), \quad |t| < T_s$$

$$p_{Gauss}(t) = \frac{1}{s_t \sqrt{2\rho}} \exp(-t^2 / 2s_t^2), \quad s_t = \sqrt{\ln 2} T_s / (2\rho BT)$$

$$p(t) = p_{MSK}(t) * p_{Gauss}(t)$$

The parameter BT shall nominally be equal to BT=0.3, i.e. the Gaussian low-pass filter shall have a 3 dB point at 7.5 MHz.

1 bit/symbol, 2 levels

Symbol	Amplitude Levels
1	1
0	-1

2 bit/symbol , 4 levels

Symbol	Amplitude Levels
10	1
11	1/3
01	-1/3
00	-1

3 bit/symbol , 8 levels

Symbol	Amplitude Levels
100	7/6
101	5/6
111	3/6
110	1/6
010	-1/6
011	-3/6
001	-5/6
000	-7/6

4 bit/symbol , 16 levels

Symbol	Amplitude Levels
1000	15/12
1001	13/12
1011	11/12
1010	9/12
1110	7/12
1111	5/12
1101	3/12
1100	1/12
0100	-1/12
0101	-3/12
0111	-5/12
0110	-7/12
0010	-9/12
0011	-11/12
0001	-13/12
0000	-15/12

Table 47, Symbol Encoding into Amplitude Levels

1.6.10 Channel Data Rate

A compliant 802.11 OQM PMD shall be capable of transmitting and receiving at a nominal symbol rate of 25.0 Msymbols/s \pm 10 ppm.

1.6.11 Channel Switching/Settling Time

The time to change from one operating channel frequency, as specified in 14.6.3, is defined as 224 μ s. A conformant PMD meets this switching time specification when the operating channel center frequency has settled to within \pm 60 kHz of the nominal channel center frequency as outlined in subclause 14.6.3.

1.6.12 Receive to Transmit Switch Time

The maximum time for a conformant PMD to switch the radio from the receive state to the transmit state and place the start of the first bit on the air shall be 19 μ s. At the end of this 19 μ s, the RF carrier shall be within the nominal transmit power level range, and within the described modulation specifications.

1.6.13 PMD Transmit Specifications

The following portion of this subclause describes the transmit functions and parameters associated with the Physical Medium Dependent sublayer. In general, these are specified by primitives from the PLCP and the Transmit PMD entity provides the actual means by which the signals required by the PLCP primitives are imposed onto the medium.

1.6.13.1 Nominal Transmit Power

The nominal transmit power of a frame is defined as the power averaged between the start of the first symbol in the PLCP header to the end of the last symbol in the PLCP header. When in the transmit state, the transmit power shall be within 2 dB of the nominal transmit power from the start of the preamble SYNC field to the last symbol at the end of the frame.

1.6.13.2 Transmit Power Levels

Unless governed by more stringent local geographic regulations, the radiated emissions from compliant devices shall meet ANSI C95.1-1991 (latest revision) limits for controlled or uncontrolled environments, in accordance with their intended usage. In addition, all conformant PMD implementations shall support at least one power level with a minimum Equivalent Isotropically Radiated Power (EIRP) of 10 mW.

1.6.13.3 Transmit Power Level Control

If a conformant PMD implementation has the ability to transmit in a manner that results in the EIRP of the transmit signal exceeding the level of 250 mW, at least one level of transmit power control shall be implemented. This transmit power control shall be such that the level of the emission is reduced to a level at or below 100 mW under the influence of said power control.

1.6.13.4 Transmit Spectrum Shape

Within the operational frequency band the transmitter shall pass a spectrum mask test. The duty cycle between Tx and Rx is nominally 50% and the transmit frame length is nominally 400 μ s. The adjacent channel power is defined as the sum of the power measured in a 1 MHz band. For a pseudorandom data pattern, the adjacent channel power shall be a function of the offset between channel number N and the assigned transmitter channel M, where M is the actual transmitted center frequency and N a channel separated from it by an integer number of MHz.

Channel offset

$|N-M|=2$ -20dBm or -40dBc, whichever is the lower power.

$|N-M|\geq 3$ -40dBm or -60dBc, whichever is the lowest power.

The levels given in dBc are measured relative to the transmitter power measured in a 1 MHz channel centered on the transmitter center frequency. The adjacent channel power and the transmitter power for this subclause of the specification shall be measured with a resolution bandwidth of 100 kHz, a video bandwidth of 300 kHz, and a peak detector, and with the measurement device set to maximum hold.

For any transmit center frequency M , two exceptions to the spectrum mask requirements are permitted within the operational frequency band, provided the exceptions are less than -50 dBc, where each offset channel exceeded counts as a separate exception. An exception occurs when the total energy within a given 1 MHz channel as defined by 14.6.5 exceeds the levels specified above.

1.6.13.5 Transmit Center Frequency Tolerance

The PMD transmit center frequency shall be within ± 60 kHz of the nominal center frequency as specified in 14.6.5.

1.6.13.6 Transmitter Ramp Periods

The transmitter shall go from off to within 2 dB of the nominal transmit power in 0.4 μ s or less. The transmitter shall go from within 2 dB of the nominal transmit power to off (less than -50dBm) in 0.4 μ s or less.

1.6.14 PMD Receiver Specifications

The following portion of this subclause describes the receive functions and parameters associated with the Physical Medium Dependent sublayer. In general, these are specified by primitives from the PLCP. The Receive PMD entity provides the actual means by which the signals required by the PLCP primitives are recovered from the medium. The PMD sublayer monitors signals on the medium and will return to the PLCP Sublayer symbols from the set ranging from (0 .. 1) to (0 .. 15), dependent on anticipated number of bits per symbol.

1.6.14.1 Input Signal Range

The PMD shall be capable of recovering a conformant PMD signal from the medium, as described in related subclauses, with a Frame Error Ratio (FER) less than or equal to 3% for MPDUs of 400 octets generated with pseudo-random data, for receiver input signal levels in the range from -20 dBm to the receiver sensitivity (as specified in 14.6.15.4), across the frequency band of operation.

1.6.14.2 Receive Center Frequency Acceptance Range

An 802.11 OQM compliant PMD shall meet all specifications with an input signal having a center frequency range of ± 60 kHz from nominal.

1.6.14.3 Clear Channel Assessment Power Threshold

In the presence of any 802.11-compliant 1 Mbit/s OQM PMD signal above -80 dBm that starts synchronously with respect to slot times as specified in 14.3.3.2.1, the PHY shall signal busy, with a 90% probability of detection, during the preamble within the CCA assessment window. In the presence of any 802.11-compliant 25 Msymbol/s OQM PMD signal above -80 dBm that starts asynchronously with respect to slot times as specified in 14.3.3.2.1, the PHY shall signal busy, with a 70% probability of

detection, during the preamble within the CCA assessment window. In the presence of any 802.11 compliant 25 Msymbol/s OQM PMD signal above -60 dBm, the PHY shall signal busy, with a 70% probability of detection, during random data within the CCA assessment window. This specification applies to a PMD operating with a nominal EIRP of < 250 mW. A compliant PMD operating at a nominal output power greater than 250 mW shall use the following equation to define the CCA threshold, where P_t represents Transmit Power.

$$\text{CCA Threshold (Preamble)} = -85 \text{ dBm} - (5 * \log_{10}(P_t / 250 \text{ mW})) \text{ dBm}$$

$$\text{CCA Threshold (Random Data)} = \text{CCA Threshold (Preamble)} + 20 \text{ dB}$$

1.6.14.4 Receiver Sensitivity

The sensitivity is defined as the minimum signal level required for a Frame Error Ratio (FER) of 3% for MPDUs of 400 octets generated with pseudo random data. The sensitivity shall be less than or equal to stated in Table xxxx, depending on data rate.

Modulation	ECC	Data Rate	Sensitivity
2-level	with ECC	21 Mbit/s	-77 dBm
2-level	w/o ECC	25 Mbit/s	-75 dBm
4-level	with ECC	42 Mbit/s	-67 dBm
4-level	w/o ECC	50 Mbit/s	-65 dBm
8-level	with ECC	63 Mbit/s	-60 dBm
8-level	w/o ECC	75 Mbit/s	-58 dBm
16-level	with ECC	84 Mbit/s	-52 dBm
16-level	w/o ECC	100 Mbit/s	-50 dBm

1.6.14.5 Intermodulation

Intermodulation protection (IMp) is defined as the ratio of the minimum amplitude of one of two equal interfering signals to the desired signal amplitude, where the interfering signals are spaced 4 and 8 Mhz removed from the center frequency of the desired signal, both on the same side of center frequency. The IMp protection ratio is established at the interfering signal level that causes the FER of the receiver to be increased to 3% for MPDUs of 400 octets generated with pseudo random data, when the desired signal is -77 dBm. Each interfering signal is modulated with the OQM PMD modulation uncorrelated in time to each other or the desired signal. The PMD shall have the IMp for the interfering signal at 4 and 8 MHz be greater than or equal to 30 dB.

1.6.14.6 Desensitization

Desensitization (Dp) is defined as the ratio to measured sensitivity of the minimum amplitude of an interfering signal that causes the FER at the output of the receiver to be increased to 3% for MPDUs of 400 octets generated with pseudo random data, when the desired signal is -77 dBm. The interfering signal shall be modulated with the OQM PMD modulation uncorrelated in time to the desired signal. The minimum Dp shall be as given in Table 46, 1 Mbit/s Desensitization. The spectral purity of the interferer shall be sufficient to ensure that the measurement is limited by the receiver performance.

Interferer Frequency*	DP Minimum
M=N±2	30 dB
M=N±3 or more	40 dB

Table 46, 1 Mbit/s Desensitization

*where M is the interferer frequency and N is the desired channel frequency

1.6.14.7 Receiver Radiation

The signal leakage when receiving shall not exceed -50 dBm EIRP in the operating frequency range.

1.6.15 Operating Temperature Range

Two temperature ranges for full operation compliance to the OQM PHY are specified. Type 1 is defined as 0° to 40° C is designated for office environments. Type 2 is defined as -30° to 70° C and is designated for industrial environments.

1.7 OQM PHY Management Information Base

1.7.1 Introduction

The following is the Management Information Base for the Frequency Hopping Spread Spectrum PHY.

1.7.2 OQM PHY Attributes

This subclause defines the attributes for the OQM MIB. Table 49 lists these attributes and the default values. Following the table is a description of each attribute.

Attribute	Default Value	Operational Semantics	Operational Behavior
aPHYType	OQM = 04h	Static	Identical for all OQM PHYs
aRegDomainsSupported	FCC = 10h	Static	Implementation dependent
aCurrentRegDomain	00h	Dynamic LME	Implementation dependent
aSlotTime	6.0 μ s	Static	Identical for all OQM PHYs
aCCATime	3.0 μ s	Static	Identical for all OQM PHYs
aRxTxTurnaroundTime	1.4 μ s	Static	Identical for all OQM PHYs
aTxPLCPDelay	0.4 μ s	Static	Identical for all OQM PHYs
aRxTxSwitchTime	0.4 μ s.	Static	Identical for all OQM PHYs
aTxRampOnTime	0.4 μ s.	Static	Identical for all OQM PHYs
aTxRFDelay	0.4 μ s.	Static	Identical for all OQM PHYs
aSIFSTime	12.0 μ s.	Static	Identical for all OQM PHYs
aRxRFDelay	1.0 μ s.	Static	Identical for all OQM PHYs
aRxPLCPDelay	7.0 μ s.	Static	Identical for all OQM PHYs
aMACProcessingDelay	0.6 μ s.	Static	Identical for all OQM PHYs
aTxRampOffTime	0.4 μ s.	Static	Identical for all OQM PHYs
aPreambleLength	10.24 μ s	Static	Identical for all OQM PHYs
aPLCPHdrLength	3.2 μ s	Static	Identical for all OQM PHYs
aMPDUDurationFactor	1.1923 (if ECC used)	Static	Identical for all OQM PHYs
aAirPropagationTime	1 μ s.	Static	Identical for all OQM PHYs
aTempType	Type 1 = 01h Type 2 = 02h Type 3 = 03h	Static	Implementation dependent
aCWmin	15	Static	Identical for all OQM PHYs
aCWmax	1023	Static	Identical for all OQM PHYs
aSupportedDataRatesTX	20.9677 Mbit/s = 01h Mandatory All other - Optional 25.0000 Mbit/s = 02h 41.9355 Mbit/s = 03h 50.0000 Mbit/s = 04h 62.9032 Mbit/s = 05h 75.0000 Mbit/s = 06h 83.8710 Mbit/s = 07h 100.0000 Mbit/s = 08h	Static	Identical for all OQM PHYs
aSupportedDataRatesRX	20.9677 Mbit/s = 01h Mandatory All other - Optional 25.0000 Mbit/s = 02h 41.9355 Mbit/s = 03h 50.0000 Mbit/s = 04h 62.9032 Mbit/s = 05h 75.0000 Mbit/s = 06h 83.8710 Mbit/s = 07h 100.0000 Mbit/s = 08h	Static	Identical for all OQM PHYs
aMPDUMaxLength	4095 octets	Static	Identical for all OQM PHYs
aSupportedTxAntennas	Ant 1 = 01h Ant 2 = 02h Ant 3 = 03h Ant n = n	Static	Implementation dependent

aCurrentTxAntenna	Ant 1 = default	Dynamic LME	Implementation dependent
aSupportedRxAntennas	Ant 1 = 01h Ant 2 = 02h Ant 3 = 03h Ant n = n	Static	Implementation dependent
aDiversitySupport	Available = 01h Not Avail. = 02h Control Avail = 03h	Static	Implementation dependent
aDiversitySelectionRx	Ant 1 = 01h Ant 2 = 02h Ant 3 = 03h Ant 4 = 04h Ant 5 = 05h Ant 6 = 06h Ant 7 = 07h Ant 8 = 08h	Dynamic LME	Implementation dependent
aNumberSupportedPowerLevels	Lvl1 = 01h Lvl2 = 02h Lvl3 = 03h Lvl4 = 04h Lvl5 = 05h Lvl6 = 06h Lvl7 = 07h Lvl8 = 08h	Static	Implementation dependent
aTxPowerLevel1	Factory def. Default	Static	Implementation dependent
aTxPowerLevel2	Factory def.	Static	Implementation dependent
aTxPowerLevel3	Factory def.	Static	Implementation dependent
aTxPowerLevel4	Factory def.	Static	Implementation dependent
aTxPowerLevel5	Factory def.	Static	Implementation dependent
aTxPowerLevel6	Factory def.	Static	Implementation dependent
aTxPowerLevel7	Factory def.	Static	Implementation dependent
aTxPowerLevel8	Factory def.	Static	Implementation dependent
aCurrentTxPowerLevel	TxPowerLevel1	Dynamic LME	Implementation dependent
aHopTime	TBD μ s	Static	Identical for all OQM PHYs
aCurrentChannelNumber	00h	Dynamic PLME	
aMaxDwellTime	TBD K μ s	Static	Regulatory Domain dependent
aCurrentSet	00h	Dynamic PLME	
aCurrentPattern	00h	Dynamic PLME	
aCurrentIndex	00h	Dynamic PLME	
aCurrentPowerState	01h Off 02h On	Dynamic LME	

Table 49, OQM PHY Attributes

Notes: The column titled Operational Semantics contains two types: static and dynamic. Static MIB attributes are fixed and can not be modified for a given PHY implementation. MIB Attributes defined as dynamic can be modified by some management entity. Whenever an attribute is defined as dynamic, the column also shows which entity has control over the attribute. LME refers to the MAC subLayer Management Entity while PHY refers to the PHY Layer Management Entity (PLME).

1.7.2.1 OQM PHY Attribute Definitions

1.7.2.1.1 aPHYType

The aPHYType is Frequency Hopping Spread Spectrum. The LME uses this attribute to determine what PLCP and PMD is providing services to the MAC. It also is used by the MAC to determine what MAC subLayer Management State machines must be invoke to support the PHY. The value of this attribute is defined as the integer 04h to indicate the OQM PHY.

1.7.2.1.2 aRegDomainsSupported.

Operational requirements for OQM PHY are defined by agencies representing certain geographical regulatory domains. These regulatory agencies may define limits on various parameters that differ from region to region. This parameters may include aTxPowerLevels, and aMaxDwellTime, as well as the total number of frequencies in the hopping pattern. The following values indicate regulatory agencies supported by this document:

Code Point	Regulatory Agency	Region
10h	FCC	United States
00h	Null Terminator	

Table 50, Regulatory Domain Codes

Since a PLCP and PMD might be designed to support operation in more than one regulatory domain, this attribute can actually represent a list of agencies. This list can be one or more of the above agencies and must be terminated using the null terminator. Upon activation of the PLCP and PMD, the information in this list must be used to set the value of the aCurrentRegDomain attribute.

1.7.2.1.3 aCurrentRegDomain.

The aCurrentRegDomain attribute for the OQM PHY is defined as the regulatory domain under which the PMD is currently operating. This value must be one of the values listed in the aRegDomainsSupported list. This MIB attribute is managed by the LME.

1.7.2.1.4 aSlotTime.

The aSlotTime is a PHY dependent attribute used by the MAC sublayer to determine the PIFS and DIFS periods. It is defined using the following equation:

$$aCCATime + aRxTxTurnaroundTime + aAirPropagationTime + aMACProcessingDelay$$

For the OQM PHY, the aCCATime is 3.0 μ s. and the aRxTxTurnaroundTime is 1.6 μ s. The aAirPropagationTime is fixed at 0.8 μ s. The aMACProcessingDelay is nominally 0.6 μ s. The value of this attribute is 6 μ s.

1.7.2.1.5 aCCATime.

The aCCATime for the OQM PHY is defined as the time the receiver must use to evaluate the medium at the antenna to determine the state of the channel. This time period for the OQM PHY is 3 μ s. This period includes the aRxRFDelay and the aRxPLCPDelay.

1.7.2.1.6 aRxTxTurnaround Time.

The aRxTxTurnaroundTime for the OQM PHY is defined as the time it takes a station to place a valid symbol on the medium after a PHY-TXSTART.request. The aRxTxTurnaroundTime is determined using the following equation.

$$aTxPLCPDelay + aRxTxSwitchTime + aTxRampOnTime + aTxRFDelay$$

For the OQM PHY, the aTxPLCPDelay is 0.4 μ s., the aRxTxSwitchTime is 0.4 μ s., the aTxRampOnTime is 0.4 μ s., and the aTxRFDelay is 0.4 μ s, for a total of 1.6 μ s. This is the maximum time for getting valid data on the medium. Stations can use less time but not more than 1.6 μ s.

1.7.2.1.7 aTxPLCPDelay

The aTxPLCPDelay for the OQM PHY is defined as the delay the PLCP introduces in getting data onto the air in the transmit direction. This value for the OQM PHY is nominally 0.4 μ s. Implementations may chose to increase or decrease this delay as long as the requirements of aRxTxTurnaroundTime are met.

1.7.2.1.8 aRxTxSwitchTime.

The aRxTxSwitchTime for the OQM PHY is defined as the delay the PMD requires to change from receive to transmit. This value for the OQM PHY is nominally 0.4 μ s. Implementations may chose to increase or decrease this delay as long as the requirements of aRxTxTurnaroundTime are met.

1.7.2.1.9 aTxRampOnTime.

The aTxRampOnTime for the OQM PHY is defined as the delay the PMD requires to turn on the transmit power amplifier. This value for the OQM PHY is nominally 0.4 μ s. Implementations may chose to increase or decrease this delay as long as the requirements of aRxTxTurnaroundTime are met.

1.7.2.1.10 aTxRFDelay.

The aTxRFDelay for the OQM PHY is defined as the de nominal time in μ s between the issuance of a PMDDATA.request to the PMD and the start of the corresponding symbol at the air interface. The start of a symbol is defined to be 1/2 symbol period prior to the center of the symbol. This value for the OQM PHY is nominally 0.4 μ s. Implementations may chose to increase or decrease this delay as long as the requirements of aRxTxTurnaroundTime are met.

1.7.2.1.11 aSIFSTime.

The aSIFSTime for the OQM PHY is defined as the time the MAC and PHY sublayers will require to receive the last symbol of a frame at the air interface, process the frame and respond with the first symbol of a preamble on the air interface. The aSIFSTime is determined using the following equation.

$$aRxRFDelay + aRxPLCPDelay + aMACProcessingDelay + aRxTxTurnaroundTime$$

For the OQM PHY, the aRxRFDelay is 1.0 μ s, the aRxPLCPDelay is 6.8 μ s, the aMACProcessingDelay is 0.6 μ s, and the aRxTxTurnaroundTime is 1.6 μ s, for a total of 10 μ s. This is the nominal value for aSIFSTime. In order to account for variations between implementations, this value has a tolerance as specified in 9.2.3.1.

1.7.2.1.12 aRXRFDelay.

The aRXRFDelay for the OQM PHY is defined as the The nominal time in μs between the end of a symbol at the air interface to the issuance of a PMDDATA.indicate to the PLCP. The end of a symbol is defined to be 1/2 symbol period after the center of the symbol. This value for the OQM PHY is nominally 1.0 μs . Implementations may chose to increase or decrease this delay as long as the requirements of aSIFSTime and aCCATime are met.

1.7.2.1.13 aRxPLCPDelay.

The aRxPLCPDelay for the OQM PHY is defined as the delay the PLCP introduces in the data path between the PMD and the MAC sublayer. This value for the OQM PHY is nominally 6.8 μs . This time is dominated by the need to transfer the last frame of data after error correction. Implementations may chose to increase or decrease this delay as long as the requirements of aSIFSTime and aCCATime are met.

1.7.2.1.14 aMACProcessingDelay.

The aMACProcessingDelay for the OQM PHY is defined as the delay between when a PHY-RXEND.indicate is issued by the PHY till a corresponding PHY-TXSTART.request is issued by the MAC. This value for the OQM PHY is nominally 0.6 μs . Implementations may chose to increase or decrease this delay as long as the requirements of aSIFSTime are met.

1.7.2.1.15 aTxRampOffTime.

The aTxRampOffTime for the OQM PHY is defined as the delay the PMD requires to turn off the transmit power amplifier. This value for the OQM PHY is a maximum of 0.4 μs .

1.7.2.1.16 aPreambleLength

The parameter aPreambleLength defines the time required by the OQM PHY to transmit the PLCP Preamble. This value for the 25 Msymbol/s OQM PHY is 10.24 μs .

1.7.2.1.17 aPLCPHdrLength

The parameter aPLCPHdrLength defines the time required by the OQM PHY to transmit the PLCP Header. This value for the 25 Msymbol/s OQM PHY is 3.2 μs .

1.7.2.1.18 aMPDUDurationFactor

The parameter aMPDUDurationFactor defines the overhead added by the PHY to the MPDU as it is transmitted over the air. This parameter depends on the data rate. For the OQM PHY, this factor is 1.1923=31/26 if Hamming ECC is used, otherwise it is 1.000. The total time to transmit an MPDU over the air is the following equation (accurate to within 1.6 μs due to size of last frame) :

$$\begin{aligned} & \text{aPreambleLength} + \text{aPLCPHdrLength} \\ & + \text{aMPDUDurationFactor} \times (8 \times \text{MPDU Length (octets)}) / \text{data rate} \end{aligned}$$

1.7.2.1.19 aAirPropagationTime

The parameter aAirPropagationTime is the time it takes a transmitted signal to go from the transmitting station to the receiving station. A nominal value of 0.8 μs has been allocated for this parameter. Variations in the actual propagation time are accounted for in the allowable range of aSIFSTime.

1.7.2.1.20 aTempType

SAME

1.7.2.1.21 aCWmin

SAME

1.7.2.1.22 aCWmax

SAME

1.7.2.1.23 aCurrentPowerState.

SAME

1.7.2.1.24 aSupportedDataRatesTX.

The aSupportedDataRatesTX attribute for the OQM PHY is defined as a null terminated list of supported data rates in the transmit mode for this implementation. The table below shows the possible values appearing in the list

Code Point	Data Rate
01h	20.9677 Mbit/s
02h	25.0000 Mbit/s
03h	41.9355 Mbit/s,
04h	50.0000 Mbit/s,
05h	62.9032 Mbit/s,
06h	75.0000 Mbit/s,
07h	83.8710 Mbit/s,
08h	100.0000 Mbit/s
00h	Null Terminator

Table 51, Supported Data Rate Codes**1.7.2.1.25 aSupportedDataRatesRX.**

The aSupportedDataRatesRX attribute for the OQM PHY is defined as a null terminated list of supported data rates in the receive mode for this implementation. The table below shows the possible values appearing in the list

Code Point	Data Rate
01h	20.9677 Mbit/s
02h	25.0000 Mbit/s
03h	41.9355 Mbit/s,
04h	50.0000 Mbit/s,
05h	62.9032 Mbit/s,
06h	75.0000 Mbit/s,
07h	83.8710 Mbit/s,
08h	100.0000 Mbit/s
00h	Null Terminator

Table 52, Supported Data Rate Codes

1.7.2.1.26 aMPDUMaxLength

The aMPDUMaximumLength attribute for the OQM PHY is defined as the maximum MPDU, in octets, that the PHY shall ever be capable of accepting. This value for the OQM PHY is set at 4095 octets.

Fragmentation recommendations here?

1.7.2.1.27 aSupportedTxAntennas.

SAME

1.7.2.1.28 aCurrentTxAntenna.

SAME

1.7.2.1.29 aSupportedRxAntenna.

SAME

1.7.2.1.30 aDiversitySupport.

SAME

1.7.2.1.31 aDiversitySelectionRx.

SAME

1.7.2.1.32 aNumberSupportedPowerLevels.

SAME

1.7.2.1.33 aTxPowerLevel1-8.

SAME

1.7.2.1.34 aCurrentTxPowerLevel.

The aCurrentTxPowerLevel attribute for the OQM PHY is defined as the current transmit output power level. This level shall be one of the levels implemented in the list of attributes called aTxPowerLevel N (where N is 1-8). This MIB attribute is also used to define the sensitivity of the CCA mechanism when the output power exceeds 250 mW. This MIB attribute is managed by the LME.

1.7.2.1.35 aHopTime.

The aHopTime attribute for the OQM PHY describes the time allocated for the PHY to change to a new frequency. For the OQM PHY, this time period is TBD μ s.

1.7.2.1.36 aCurrentChannelNumber.

The aCurrentChannelNumber attribute for the OQM PHY is defined as the current operating channel number of the PMD. The values of this attribute correspond to the values shown in Table 38. This MIB attribute is managed by the PLME and is updated as the result of a PLMESET.request to aCurrentSet, aCurrentPattern, or aCurrentIndex.

1.7.2.1.37 aMaxDwellTime.

The aMaxDwellTime attribute for the OQM PHY is defined as the maximum time the PMD can dwell on a channel and meet the requirements of the current regulatory domain.

1.7.2.1.38 aCurrentSet.

TBD

1.7.2.1.39 aCurrentPattern.

TBD

1.7.2.1.40 aCurrentIndex.

TBD

1.7.2.1.41 aCurrentPowerState

SAME