

Project	IEEE 802.16 Broadband Wireless Access Working Group < http://ieee802.org/16 >	
Title	WirelessMAN coexistence function primitives consolidation	
Date Submitted	2008-05-02	
Source(s)	Wu Xuyong Huawei, Huawei Industry Base, Bantian, Longgang, Shenzhen, China 518129	Voice: +86-755-28971787 Fax: +86-755-28972352 wuxuyong@huawei.com
Re:	IEEE 802.16-08/019 IEEE 802.16 Working Group Letter Ballot Recirc #29b: Announcement (2008-04-07)	
Abstract	Semantic consolidation on Coexistence Functionality primitives in 16h, moving CX proxy description into Annex and generalize the network address for basic connectivity between WirelessMAN-CX systems.	
Purpose	To consolidate the 16h draft.	
Notice	This document has been prepared to assist IEEE 802.16. It is offered as a basis for discussion and is not binding on the contributing individual(s) or organization(s). The material in this document is subject to change in form and content after further study. The contributor(s) reserve(s) the right to add, amend or withdraw material contained herein.	
Release	The contributor grants a free, irrevocable license to the IEEE to incorporate material contained in this contribution, and any modifications thereof, in the creation of an IEEE Standards publication; to copyright in the IEEE's name any IEEE Standards publication even though it may include portions of this contribution; and at the IEEE's sole discretion to permit others to reproduce in whole or in part the resulting IEEE Standards publication. The contributor also acknowledges and accepts that this contribution may be made public by IEEE 802.16.	
Patent Policy and Procedures	The contributor is familiar with the IEEE 802.16 Patent Policy and Procedures < http://ieee802.org/16/ipr/patents/policy.html >, including the statement "IEEE standards may include the known use of patent(s), including patent applications, provided the IEEE receives assurance from the patent holder or applicant with respect to patents essential for compliance with both mandatory and optional portions of the standard." Early disclosure to the Working Group of patent information that might be relevant to the standard is essential to reduce the possibility for delays in the development process and increase the likelihood that the draft publication will be approved for publication. Please notify the Chair < mailto:chair@wirelessman.org > as early as possible, in written or electronic form, if patented technology (or technology under patent application) might be incorporated into a draft standard being developed within the IEEE 802.16 Working Group. The Chair will disclose this notification via the IEEE 802.16 web site < http://ieee802.org/16/ipr/patents/notices >.	

WirelessMAN coexistence function primitives consolidation

Wu Xuyong
Huawei

Overview

In letter ballot recirculation 29a, we have notice that some content in P802.16h-D5 is describing the IP level activity and beyond the scope of 802.16, we should do cleaning up to:

- 1) Remove IP activity description or put it into informative annex.*
- 2) Define the primitives to enable the coexistence function in WirelessMAN-CX systems.*

Reference:

- [1] IEEE 80216-08_009r4: Letter Ballot Recirc #29a Comment Database (2008-04-07)
- [2] IEEE P802.16h/D5: 802.16h draft 5(2008-03-22)
- [3] IEEE 802.16-08/019: IEEE 802.16 Working Group Letter Ballot #29b: Announcement (2008-04-07)
- [4] IEEE 802.16-2004: IEEE Standard for Local and metropolitan area networks Part 16: Air Interface for Fixed Broadband Wireless Access Systems (2004-10-01)
- [5] IEEE 802.16e-2005: IEEE Standard for Local and metropolitan area networks Part 16: Air Interface for Fixed and Mobile Broadband Wireless Access Systems Amendment 2: Physical and Medium Access Control Layers for Combined Fixed and Mobile Operation in Licensed Bands and Corrigendum 1 (2006-02-28)
- [6] P802.16Rev2/D4: (April 2008) DRAFT Standard for Local and metropolitan area networks Part 16: Air Interface for Broadband Wireless Access Systems

Proposed Text Changes:

Modified the figure 3 in 1.4.4 accordingly:

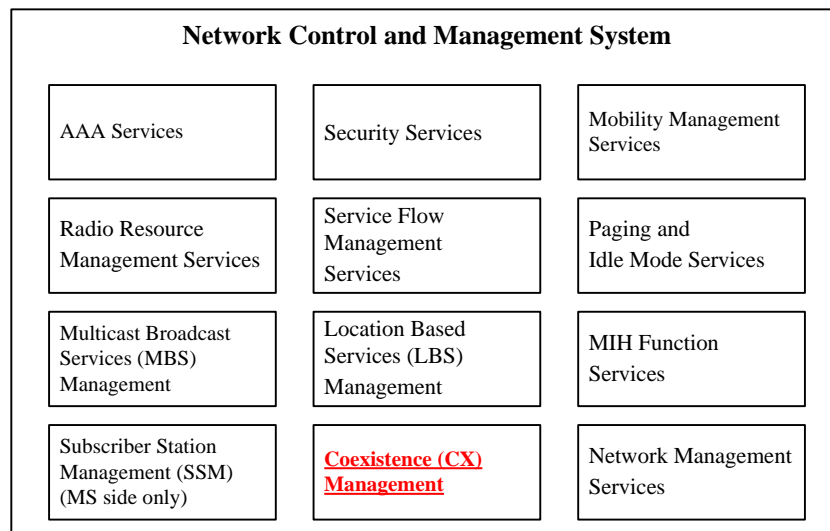

Add a new section 14.2.12 in 14.2, or replace according content in 15.6 with following:

15.6(or 14.2.12) Coexistence Management:

The CX primitives are a set of primitives for supporting CX procedures between BS and NCMS.

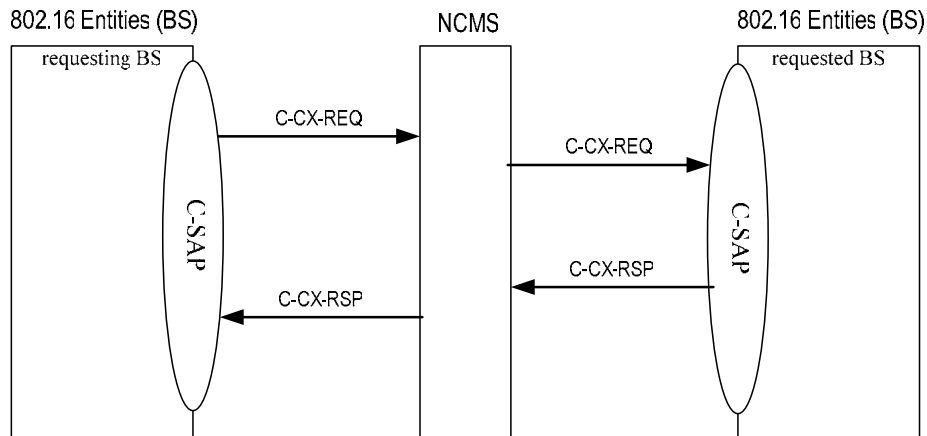

Figure xx1. primitive flow of C-CX-REQ/RSP

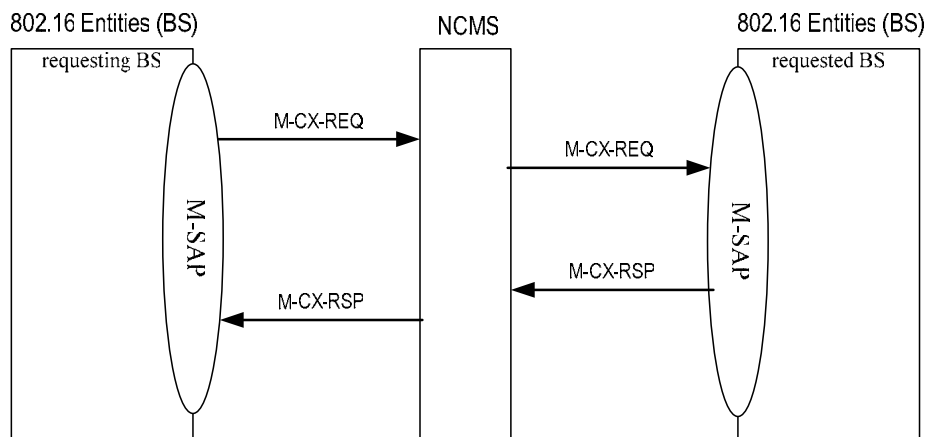

Figure xx2. primitive flow of M-CX-REQ/RSP

15.6.1(or 14.2.12.1) C-CX-REQ

This primitive is used by an 802.16 entity or NCMS to request a coexistence reaction. The Action Type included in this primitive defines the type of coexistence procedure to be performed. The possible Action_Types for this primitive are listed in Table below:

Action Type	Description
Add neighbor	Add coexistence neighbor procedure in the WirelessMAN-CX system.
Delete neighbor	Delete coexistence neighbor procedure in the WirelessMAN-CX system.
.....

The following sub-sections define the primitive when its action type is set to a specific action.

15.6.1.1(or 14.2.12.1.1) C-CX-REQ (Action Type = Add neighbor)

Function:

This primitive is used by an 802.16 entity (BS) or NCMS to request adding the requesting BS into the neighborhood contact list of the requested BS.

Semantics of the service primitive:

The parameters of the primitive are as follow:

C-CX-REQ

(
Operation Type: Action,
Action Type: Add neighbor,
Destination: BS, NCMS,
Attribute List:
BSID,
Contact Network address,
Channel Center Frequency,
Channel Width,
Channel information
)

<u>Attribute</u>	<u>Contents</u>
<u>BSID</u>	<u>The BSID of the requested BS.</u>
<u>Contact Network address</u>	<u>The IP address of the requested BS or the agent of the requested BS.</u>
<u>Channel Center Frequency</u>	<u>in10kHz</u>
<u>Channel Width</u>	<u>in10kHz</u>
<u>Channel information</u>	<u>The channel information of the requesting BS. Containing: Modulation mode (0-reserved; 1-OFDM; 2-OFDMA; 3-15 reserved) alternative Channel Flag (0- no ALTCH; 1-have ALTCH)</u>

When generated:

• 802.16 entity (BS) to NCMS:

This primitive is used by the 802.16 entity (BS) to request the NCMS to inform the requested BS to add the requesting BS into the neighborhood contact list, while the WirelessMAN-CX system of the requesting BS have discover the requested BS's system's neighboring.

• NCMS to 802.16 entity (BS) to NCMS:

This primitive is used by the NCMS to request the requested neighbor to adding the requesting BS into the neighborhood contact list, while NCMS is requested by the requesting BS.

Effect of receipt:

• NCMS:

The NCMS perform the action to inform the requested BS to add the requesting BS into the neighborhood contact list.

• 802.16 entity (BS):

The requested BS performs the coexistence procedure and response to the requesting BS accordingly.

15.6.1.2(or 14.2.12.1.2) C-CX-REQ (Action Type = Delete neighbor)**Function:**

This primitive is used by an 802.16 entity (BS) or NCMS to request deleting the requesting BS from the neighborhood contact list of the requested BS.

Semantics of the service primitive:

The parameters of the primitive are as follow:

C-CX-REQ

(
Operation Type: Action,
Action Type: Delete neighbor,
Destination: BS, NCMS,
Attribute List:
BSID,
Contact Network address
)

<u>Attribute</u>	<u>Contents</u>
<u>BSID</u>	<u>The BSID of the requested BS.</u>
<u>Contact Network address</u>	<u>The IP address of the requested BS or the agent of the requested BS.</u>

When generated:

- 802.16 entity (BS) to NCMS:**

This primitive is used by the 802.16 entity (BS) to request the NCMS to inform the requested BS to delete the requesting BS from the neighborhood contact list, while the WirelessMAN-CX system of the requesting BS is stop neighboring the requested BS's system.

- NCMS to 802.16 entity (BS) to NCMS:**

This primitive is used by the NCMS to request the requested neighbor to delete the requesting BS from the neighborhood contact list, while NCMS is requested by the requesting BS.

Effect of receipt:

- NCMS:**

The NCMS perform the action to inform the requested BS to delete the requesting BS from the neighborhood contact list.

- 802.16 entity (BS):**

The requested BS performs the coexistence procedure and response to the requesting BS accordingly.

15.6.1.3(or 14.2.12.1.3) C-CX-REQ (Action Type = TBD)

TBD

15.6.1.4(or 14.2.12.1.4) C-CX-REQ (Action Type = TBD)

TBD

15.6.1.5(or 14.2.12.1.5) C-CX-REQ (Action Type = TBD)

TBD

15.6.1.6(or 14.2.12.1.6) C-CX-REQ (Action Type = TBD)

TBD

15.6.1.7(or 14.2.12.1.7) C-CX-REQ (Action Type = TBD)

TBD

15.6.1.8(or 14.2.12.1.8) C-CX-REQ (Action Type = TBD)

TBD

15.6.1.9(or 14.2.12.1.9) C-CX-REQ (Action Type = TBD)

TBD

15.6.1.10(or 14.2.12.1.10) C-CX-REQ (Action Type = TBD)

TBD

15.6.1.11(or 14.2.12.1.11) C-CX-REQ (Action Type = TBD)

TBD

15.6.1.12(or 14.2.12.1.12) C-CX-REQ (Action Type = TBD)

TBD

15.6.1.13(or 14.2.12.1.13) C-CX-REQ (Action Type = TBD)

TBD

15.6.1.14(or 14.2.12.1.14) C-CX-REQ (Action Type = TBD)

TBD

15.6.1.15(or 14.2.12.1.15) C-CX-REQ (Action Type = TBD)

TBD

15.6.2(or 14.2.12.2) C-CX-RSP

This primitive is used by an 802.16 entity or NCMS to response to a request in coexistence procedure. The Action Type included in this primitive defines the type of coexistence procedure to be performed. The possible Action Types for this primitive are listed in Table below:

<u>Action Type</u>	<u>Description</u>
<u>Add neighbor</u>	<u>Add coexistence neighbor procedure in the WirelessMAN-CX system.</u>
<u>Delete neighbor</u>	<u>Delete coexistence neighbor procedure in the WirelessMAN-CX system.</u>
<u>.....</u>	<u>.....</u>

The following sub-sections define the primitive when its action type is set to a specific action.

15.6.2.1(or 14.2.12.2.1) C-CX-RSP (Action Type = Add neighbor)

Function:

This primitive is used by an 802.16 entity (BS) or NCMS to respond the request of adding the requesting BS into the neighborhood contact list of the responding BS.

Semantics of the service primitive:

The parameters of the primitive are as follow:

C-CX-RSP

```
(
  Operation Type: Action,
  Action Type: Add neighbor,
  Destination: BS, NCMS,
  Attribute List:
    No attribute.
)
```

15.6.2.2(or 14.2.12.2.2) C-CX-RSP (Action Type = Delete neighbor)

Function:

This primitive is used by an 802.16 entity (BS) or NCMS to respond the request of deleting the requesting BS from the neighborhood contact list of the responding BS.

Semantics of the service primitive:

The parameters of the primitive are as follow:

C-CX-RSP

```
(
  Operation Type: Action,
  Action Type: Delete neighbor,
  Destination: BS, NCMS,
  Attribute List:
    No attribute.
)
```

15.6.2.3(or 14.2.12.2.3) C-CX-RSP (Action Type = TBD)

TBD

15.6.2.4(or 14.2.12.2.4) C-CX-RSP (Action Type = TBD)

TBD

15.6.2.5(or 14.2.12.2.5) C-CX-RSP (Action Type = TBD)

TBD

15.6.2.6(or 14.2.12.2.6) C-CX-RSP (Action Type = TBD)

TBD

15.6.2.7(or 14.2.12.2.7) C-CX-RSP (Action Type = TBD)

TBD

15.6.2.8(or 14.2.12.2.8) C-CX-RSP (Action Type = TBD)

TBD

15.6.2.9(or 14.2.12.2.9) C-CX-RSP (Action Type = TBD)

TBD

15.6.2.10(or 14.2.12.2.10) C-CX-RSP (Action Type = TBD)

TBD

15.6.2.11(or 14.2.12.2.11) C-CX-RSP (Action Type = TBD)

TBD

15.6.2.12(or 14.2.12.2.12) C-CX-RSP (Action Type = TBD)

TBD

15.6.2.13(or 14.2.12.2.13) C-CX-RSP (Action Type = TBD)

TBD

15.6.2.14(or 14.2.12.2.14) C-CX-RSP (Action Type = TBD)

TBD

15.6.2.15(or 14.2.12.2.15) C-CX-RSP (Action Type = TBD)

TBD