



Received:

Reference: Question ITU-R 229-2/5

DRAFT

Document 5D/IEEE-xx-E

xx March 2011

English only

TECHNOLOGY ASPECTS

Institute of Electrical and Electronics Engineers (IEEE)

PROPOSED MODIFICATIONS TO THE WORKING DOCUMENT TOWARDS
PDNR M.[IMT.RSPEC]

1

2 [Introduction to be inserted]

3

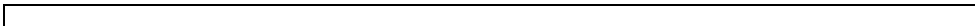

SWG IMT Specifications

WORKING DOCUMENT TOWARDS A PRELIMINARY DRAFT
NEW RECOMMENDATION ITU-R M.[IMT.RSPEC]

Detailed specifications of the terrestrial radio interfaces of IMT-Advanced

1

2 1 Introduction

3 International Mobile Telecommunications-Advanced (IMT-Advanced) systems are mobile systems that include the
4 new capabilities of IMT that go beyond those of IMT-2000. Such systems provide access to a wide range of
5 telecommunication services including advanced mobile services, supported by mobile and fixed networks, which are
6 increasingly packet-based.

7 IMT-Advanced systems support low to high mobility applications and a wide range of data rates in accordance with
8 user and service demands in multiple user environments. IMT-Advanced also has capabilities for high-quality
9 multimedia applications within a wide range of services and platforms providing a significant improvement in
10 performance and quality of service.

11 The key features of IMT-Advanced are:

- 12 – a high degree of commonality of functionality worldwide while retaining the flexibility to support a wide
13 range of services and applications in a cost efficient manner;
- 14 – compatibility of services within IMT and with fixed networks;
- 15 – capability of interworking with other radio access systems;
- 16 – high-quality mobile services;
- 17 – user equipment suitable for worldwide use;
- 18 – user-friendly applications, services and equipment;
- 19 – worldwide roaming capability;
- 20 – enhanced peak data rates to support advanced services and applications (100 Mbit/s for high and 1 Gbit/s
21 for low mobility were established as targets for research)¹.

22 These features enable IMT-Advanced to address evolving user needs.

23 The capabilities of IMT-Advanced systems are being continuously enhanced in line with user trends and technology
24 developments.

25 2 Scope

26 This Recommendation identifies the detailed terrestrial radio interface specifications of IMT-Advanced.

27 These radio specifications detail the design features and design parameters of IMT-Advanced. This
28 Recommendation includes the capability to ensure worldwide compatibility, international roaming, and access to
29 high-speed data services.

¹ Data rates sourced from Recommendation ITU-R M.1645.

1 *[Editor's note: the previous paragraph might need additional consideration to reflect some of the views expressed,*
2 *e.g., in Res 57, M.1822, and M.2133]*

3 **3 Related ITU-R Recommendations and Reports**

- 4 Recommendation ITU-R M.1036
- 5 Recommendation ITU-R M.1457
- 6 Recommendation ITU-R M.1579
- 7 Recommendation ITU-R M.1580
- 8 Recommendation ITU-R M.1581
- 9 Recommendation ITU-R M.1645
- 10 Recommendation ITU-R M.1768
- 11 Recommendation ITU-R M.1822
- 12 Recommendation ITU-T Q.1741
- 13 Recommendation ITU-T Q.1742
- 14 Report ITU-R M.2038
- 15 Report ITU-R M.2072
- 16 Report ITU-R M.2074
- 17 Report ITU-R M.2078
- 18 Report ITU-R M.2079
- 19 Report ITU-R M.2133.
- 20 Report ITU-R M.2134
- 21 Report ITU-R M.2135-1.
- 22 Report ITU-R M.[IMT.RADIO].

23 **4 Acronyms and abbreviations**

24 *[Editor's Note: to be added]*

25

1

2 **5 Notings and considerations**

3 The ITU-R Radiocommunication Assembly,

4 *noting*5 a) Report ITU-R M.[IMT.RADIO] which contains the outcome and conclusions of Step 4 through 7 of the
6 IMT-Advanced process, including the evaluation and consensus building, and provides the characteristics of the
7 IMT-Advanced terrestrial radio interfaces,8 *considering*

9 a) the possible involvement of several types of networks;

10 b) the increasing technical developments and opportunities;

11 c) the need of many users for services which are not bounded by geography or operators;

12 d) the necessity of priority services (e.g. emergency calls shall be supported as higher priority than other
13 commercial services);14 e) that the services supported by IMT will be operated in an environment which requires recognition of the
15 following factors:16 e-1) low cost: Users want diverse, affordable, and convenient mobile services. Such demands will be realized
17 by development of technology that will reduce the cost per packet;18 e-2) large effective bandwidths: to support the very high data rates that will likely be required by the various
19 services offered, allowances must be made for either much larger single carrier bandwidths (even as spectral
20 efficiencies increase) or aggregation of RF carriers;21 e-3) high data rate: services such as video phone, streaming, and video-on-demand, which are currently
22 available via wired networks will be required to be supported via wireless networks with higher broadband capacity
23 with anytime, anywhere availability;24 e-4) convergence: the rapid development of information technology (IT), including the Internet, has resulted in
25 the aggregation and convergence of various networks and digital devices. In addition to the aggregation of data and
26 voice, the integration of wired and wireless communications is ongoing;27 e-5) wide range of terminals: a wide range of terminals is desired for future mobile services. Some users may
28 need an affordable voice-centric terminal while other users would prefer a versatile mobile phone that could provide
29 not only traditional functions like telephony, but also utilities such as a digital camera, music and movie player, map
30 guidance, e-Wallet, etc. For connecting to the electric, electronic, and mechanical machine surrounding user, short-
31 range communication devices could be merged to the terminals.
32

1

2 **6 Recommendation**

3 The ITU Radiocommunication Assembly,

4 *recommends*

5 1) the radio interface specifications in the Annexes below as the terrestrial radio interfaces of IMT-Advanced:

6 Annex A: Specification of the *LTE-Advanced*² radio interface technology7 Annex B: Specification of the *WirelessMAN-Advanced*³ radio interface technology;8 2) the detailed information provided or referenced in these Annexes as the complete set of standards for the
9 terrestrial radio interfaces of IMT-Advanced.

10

11

12 **Annex A**

13

14 **Specification of the *LTE-Advanced*⁴ radio interface technology**15 **Background**16 IMT-Advanced is a system with global development activity and the IMT-Advanced terrestrial radio interface
17 specifications identified in this Recommendation have been developed by the ITU in collaboration with the **GCS**
18 **Proponents** and the **Transposing Organizations**. It is noted from document ITU-R IMT-ADV/24, that:19 - The **GCS Proponent** must be one of the **RIT/SRIT Proponents** for the relevant technology, **and** must have legal
20 authority to grant to ITU-R the relevant legal usage rights to the relevant specifications provided within a GCS
21 corresponding to a technology in Recommendation ITU-R M.[IMT.RSPEC]22 - A **Transposing Organization** must have been authorized by the relevant **GCS Proponent** to produce transposed
23 standards for a particular technology, **and** must have the relevant legal usage rights.24 It is further noted that **GCS Proponents** and **Transposing Organizations** must also qualify appropriately under the
25 auspices of ITU-R Resolution 9-3 and the ITU-R "Guidelines for the contribution of material of other organizations
26 to the work of the Study Groups and for inviting other organizations to take part in the study of specific matters
(Resolution ITU-R 9-3)".27 The ITU has provided the global and overall framework and requirements, and has developed the Global Core
28 Specification jointly with the **GCS Proponent**. The detailed standardization has been undertaken within the
29 recognized **Transposing Organizations** which operate in concert with the **GCS Proponent**. This Recommendation
30 therefore makes extensive use of references to externally developed specifications.31 This approach was considered to be the most appropriate solution to enable completion of this Recommendation
32 within the aggressive schedules set by the ITU and by the needs of administrations, operators and manufacturers.33 This Recommendation has therefore been constructed to take full advantage of this method of work and to allow the
34 global standardization time-scales to be maintained. The main body of this Recommendation has been developed by
35 the ITU, with each Annex containing references pointing to the location of the more detailed information.

2 Developed by 3GPP as *LTE Release 10 and Beyond (LTE-Advanced)*.3 Developed by IEEE as the *WirelessMAN-Advanced* specification incorporated in IEEE Std 802.16 beginning with approval of IEEE Std 802.16m.4 Developed by 3GPP as *LTE Release 10 and Beyond (LTE-Advanced)*.

1 This Annex A contains the detailed information developed by the ITU and “ARIB, ATIS, CCSA, ETSI, TTA, and
2 TTC on behalf of 3GPP” (the *GCS Proponent*) and [TBD] (the *Transposing Organizations*). Such use of
3 referencing has enabled timely completion of the high-level elements of this Recommendation, with change control
4 procedures, transposition, and public enquiry procedures being undertaken within the external organization.

5 The detailed specifications received from “ARIB, ATIS, CCSA, ETSI, TTA, and TTC on behalf of 3GPP” (the *GCS*
6 *Proponent*) and [TBD] (the *Transposing Organizations*) have generally been adopted unchanged, recognizing the
7 need to minimize duplication of work, and the need to facilitate and support an on-going maintenance and update
8 process.

9 This general agreement, that the detailed specifications of the radio interface should to a large extent be achieved by
10 reference to the work of external organizations, highlights not only the ITU’s significant role as a catalyst in
11 stimulating, coordinating and facilitating the development of advanced telecommunications technologies, but also its
12 forward-looking and flexible approach to the development of this and other telecommunications standards for the
13 21st century.

14 A more detailed understanding of the process for the development of this Recommendation may be found in
15 Document ITU-R IMT-ADV/24.

16 **A.1 Overview of the radio interface technology**

17 *[Editor’s Note: to be filled with stakeholder’s input(s)]*

18 **A.2 Detailed specification of the radio interface technology**

19 Detailed specifications described in this Recommendation are developed around a “Global Core Specification”
20 (GCS)⁵, which is related to externally developed materials incorporated by specific references for a specific
21 technology. The process and use of the GCS, references, and related notifications and certifications are found as
22 IMT-ADV/24⁶

23 The standards contained in this section are derived from the global core specifications for IMT-Advanced contained
24 at <http://ties.itu.int/u/itu-r/ede/rsg5/xxxxx/xxx/xxxxxxx/>. The following notes apply to the sections below, where
25 indicated:

26 1) The [relevant][TBD] (the *Transposing Organisations*) should make their reference material available
27 from their web site.

28 2) This information was supplied by the *Transposing Organizations* and relates to their own deliverables of
29 the transposed global core specification.

30 *[Editor’s note: the above notes will be revisited when the final version of IMT.RSPEC will be finalised]*

31 *[Editor’s Note: to be filled with stakeholder’s input(s)]*

32

⁵ A “GCS” (Global Core Specification) is the set of specifications that defines a single RIT, an SRIT, or a RIT within an SRIT.

⁶ ADV/24 is available on the ITU-R WP 5D web page under the link “IMT-Advanced documents” (<http://www.itu.int/md/R07-IMT.ADV-C-0024/e>)

Annex B

Specification of the WirelessMAN-Advanced⁷ radio [interface](#) technology

4 Background

5 IMT-Advanced is a system with global development activity and the IMT-Advanced terrestrial radio interface
6 specifications identified in this Recommendation have been developed by the ITU in collaboration with the **GCS**
7 **Proponents** and the **Transposing Organizations**. It is noted from document ITU-R IMT-ADV/24, that:

8 - The **GCS Proponent** must be one of the **RIT/SRIT Proponents** for the relevant technology, **and** must have legal
9 authority to grant to ITU-R the relevant legal usage rights to the relevant specifications provided within a GCS
10 corresponding to a technology in Recommendation ITU-R M.[IMT.RSPEC]

11 - A **Transposing Organization** must have been authorized by the relevant **GCS Proponent** to produce transposed
12 standards for a particular technology, **and** must have the relevant legal usage rights.

13 It is further noted that **GCS Proponents** and **Transposing Organizations** must also qualify appropriately under the
14 auspices of ITU-R Resolution 9-3 and the ITU-R "Guidelines for the contribution of material of other organizations
15 to the work of the Study Groups and for inviting other organizations to take part in the study of specific matters
16 (Resolution ITU-R 9-3)".

17 The ITU has provided the global and overall framework and requirements, and has developed the Global Core
18 Specification jointly with the **GCS Proponent**. The detailed standardization has been undertaken within the
19 recognized **Transposing Organizations** which operate in concert with the **GCS Proponent**. This Recommendation
20 therefore makes extensive use of references to externally developed specifications.

21 This approach was considered to be the most appropriate solution to enable completion of this Recommendation
22 within the aggressive schedules set by the ITU and by the needs of administrations, operators and manufacturers.

23 This Recommendation has therefore been constructed to take full advantage of this method of work and to allow the
24 global standardization time-scales to be maintained. The main body of this Recommendation has been developed by
25 the ITU, with each Annex containing references pointing to the location of the more detailed information.
26

IEEE 10/11/9 08:17 AM

Deleted: access

⁷ Developed by IEEE as the *WirelessMAN-Advanced* specification incorporated in IEEE Std 802.16 beginning with approval of IEEE Std 802.16m.

This Annex B contains the detailed information developed by the ITU and “IEEE” (the *GCS Proponent*) and [TBD] (the *Transposing Organizations*). Such use of referencing has enabled timely completion of the high-level elements of this Recommendation, with change control procedures, transposition, and public enquiry procedures being undertaken within the external organization.

The detailed specifications received from “IEEE” (the *GCS Proponent*) and [TBD] (the *Transposing Organizations*) have generally been adopted unchanged, recognizing the need to minimize duplication of work, and the need to facilitate and support an on-going maintenance and update process.

This general agreement, that the detailed specifications of the radio interface should to a large extent be achieved by reference to the work of external organizations, highlights not only the ITU’s significant role as a catalyst in stimulating, coordinating and facilitating the development of advanced telecommunications technologies, but also its forward-looking and flexible approach to the development of this and other telecommunications standards for the 21st century.

A more detailed understanding of the process for the development of this Recommendation may be found in Document ITU-R IMT-ADV/24.

B.1 Overview of the radio interface technology

[Editor’s Note: to be filled GCS Proponents’ input(s) – the text is anticipated to be approx 10 pages]

The WirelessMAN-Advanced radio interface specification is developed by IEEE. A complete end-to-end specification based on WirelessMAN-Advanced developed by the WiMAX Forum is called WiMAX 2.

The following clauses provide an overview of the WirelessMAN-Advanced radio interface technology.

B.1.1 Protocol Structure

The MAC layer is composed of two sublayers: convergence sublayer (CS) and MAC common part sublayer (MAC CPS). For convenience, the MAC CPS functions are classified into two groups based on their characteristics as shown in Figure 1. The upper and lower classes are referred to as resource control and management functional group and medium access control functional group, respectively. The control plane functions and data plane functions are also separately classified. This would allow more organized, efficient, structured method for specifying the MAC services in the WirelessMAN-Advanced standard specification. As shown in Figure 1, the radio resource control and management functional group comprises several functional blocks including

- **Radio resource management** adjusts radio network parameters related to the traffic load, and also includes the functions of load control (load balancing), admission control and interference control.
- **Mobility management** scans neighbour BSs and decides whether MS should perform handover operation.
- **Network entry management** controls initialization and access procedures and generates management messages during initialization and access procedures.
- **Location management** supports location based service (LBS), generates messages including the LBS information, and manages location update operation during idle mode.
- **Idle mode management** controls idle mode operation, and generates the paging advertisement message based on paging message from paging controller in the core network.
- **Security management** performs key management for secure communication. Using managed key, traffic encryption/decryption and authentication are performed.
- **System configuration management** manages system configuration parameters, and generates broadcast control messages such as Superframe Header.
- **Multicast and broadcast service (MBS)** controls and generates management messages and data associated with MBS.
- **Service flow and connection management** allocates Station Identifier (STID) and Flow Identifiers (FIDs) during access/handover service flow creation procedures.

The medium access control functional group includes functional blocks which are related to physical layer and link controls such as

Input contribution

IEEE L802.16-10/0128

- 1 — **PHY control** performs PHY signalling such as ranging, channel quality measurement/feedback (CQI), and HARQ ACK or NACK signalling.
- 2
- 3 — **Control signalling** generates resource allocation messages such as advanced medium access protocol as well as specific control signalling messages.
- 4
- 5 — **Sleep mode management** handles sleep mode operation and generates management messages related to sleep operation, and may communicate with the scheduler block in order to operate properly according to sleep period.
- 6
- 7 — **Quality-of-service (QoS)** performs rate control based on QoS input parameters from connection management function for each connection.
- 8
- 9 — **Scheduling and resource multiplexing** schedules and multiplexes packets based on properties of connections.
- 10
- 11
- 12

13 The data plane includes functional blocks such as

- 14 — **Fragmentation/packing** performs fragmentation or packing of MAC Service Data Units (MSDU) based on input from the scheduling and resource multiplexing block.
- 15
- 16 — **Automatic Repeat Request (ARQ)** performs MAC ARQ function. For ARQ-enabled connections, a logical ARQ block is generated from fragmented or packed MSDUs of the same flow and sequentially numbered.
- 17
- 18 — **MAC Protocol Data Unit (PDU) formation** constructs MAC PDU (MPDU) such that BS/MS can transmit user traffic or management messages into PHY channels.
- 19
- 20
- 21

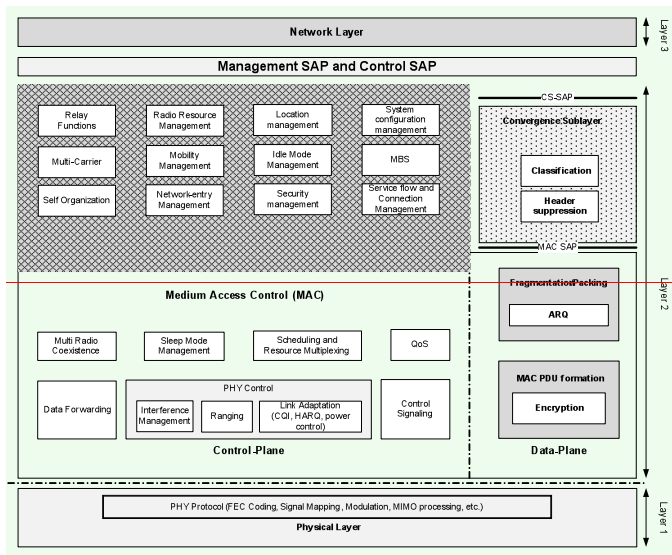

22
23 **Figure 1: IEEE WirelessMAN-Advanced Protocol Stack**

24 The WirelessMAN-Advanced protocol structure is similar to that of IMT-2000-OFDMA TDD-WMAN with some
25 additional functional blocks for new features including the following:

- 26 — **Relay functions** perform relay functionalities and packet routing in relay networks
- 27 — **Self-Organization and Self-optimization functions** performs the self-configuration and self-optimization
28 procedures based on MS measurement reports.

1 ~~— **Multi-carrier functions** enable control and operation of a number of adjacent or non-adjacent RF carriers~~
 2 ~~where the RF carriers can be assigned to unicast and/or multicast and broadcast services. A single MAC~~
 3 ~~instantiation will be used to control several physical layers. The load balancing functions and RF carrier~~
 4 ~~mapping and control are performed via radio resource control and management functional class. The~~
 5 ~~carriers utilized in a multi-carrier system, from perspective of a mobile station can be divided into two~~
 6 ~~categories:~~

7 ~~○ A primary RF carrier is the carrier that is used by the BS and the MS to exchange traffic and full~~
 8 ~~PHY/MAC control information. The primary carrier delivers control information for proper MS~~
 9 ~~operation, such as network entry. Each mobile station is assigned only one primary carrier in a cell.~~

10 ~~○ A secondary RF carrier is an additional carrier which the BS may use for traffic allocations for mobile~~
 11 ~~stations capable of multi-carrier support. The secondary carrier may also include dedicated control~~
 12 ~~signalling to support multi-carrier operation.~~

13 ~~Based on the primary and/or secondary usage, the carriers of a multi-carrier system may be configured~~
 14 ~~differently as follows:~~

15 ~~○ Fully configured carrier: A carrier for which all control channels including synchronization,~~
 16 ~~broadcast, multicast and unicast control signalling are configured. Furthermore, information and~~
 17 ~~parameters regarding multi-carrier operation and the other carriers can also be included in the control~~
 18 ~~channels. A primary carrier is fully configured, while a secondary carrier may be fully or partially~~
 19 ~~configured depending on usage and deployment model.~~

20 ~~○ Partially configured carrier: A carrier with only essential control channel configuration to support~~
 21 ~~traffic exchanges during multi-carrier operation.~~

22 ~~— **Multi-Radio Coexistence functions** provide protocols for the multi-radio coexistence functional blocks of~~
 23 ~~MS and BS to communicate with each other via air interface. MS generates management messages to~~
 24 ~~report the information about its co-located radio activities obtained from inter-radio interface and BS~~
 25 ~~generates management messages to respond with the corresponding actions to support multi-radio~~
 26 ~~coexistence operation. Furthermore, the multi-radio coexistence functional block at BS communicates with~~
 27 ~~the scheduler functional block to operate properly according to the reported co-located coexistence~~
 28 ~~activities;~~

Jeongho Park 10/12/27 01:50 PM

Comment: Seems redundant

29 B.1.2 Mobile Station State Diagram

30 The WirelessMAN-Advanced mobile state diagram (i.e., a finite set of states and procedures between which the
 31 mobile station transit when operating in the system to receive and transmit data) is shown in Figure 2:

- 32 - Initialization State: a state where a mobile station without any connection performs cell selection by
 33 scanning and synchronizing to a BS preamble and acquires the system configuration information through
 34 the superframe header.
- 35 - Access State: a state where the mobile station performs network entry to the selected base station. The
 36 mobile station performs the initial ranging process in order to obtain uplink synchronization. Then the MS
 37 performs basic capability negotiation with the BS. The MS later performs the authentication and
 38 authorization procedure. Next, the MS performs the registration process. The mobile station receives
 39 WirelessMAN-Advanced specific user identification as part of Access State procedures. The IP address
 40 assignment may follow using appropriate procedures.
- 41 - Connected State: a state consisting of the following modes: Sleep Mode, Active Mode, and Scanning
 42 Mode. During Connected State, the MS maintains at least one transport connection and two management
 43 connections as established during Access State, while the MS and BS may establish additional transport
 44 connections. In order to reduce power consumption of the MS, the MS or BS can request a transition to
 45 sleep mode. Also, the MS can scan neighbour base stations to reselect a cell which provides more robust
 46 and reliable services.

1 Idle State: a state comprising two separate modes, paging available mode and paging unavailable mode. During Idle
 2 State, the MS may save power by switching between Paging Available mode and Paging Unavailable mode. In the
 3 Paging Available mode, the MS may be paged by the BS. If the MS is paged, it transitions to the Access State for its
 4 network re-entry. The MS performs location update procedure during Idle State.

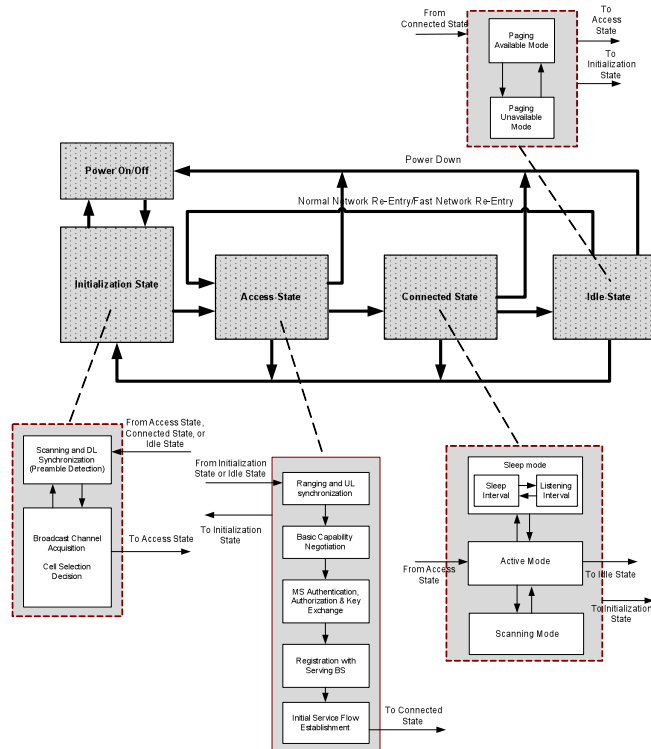

Figure 2: Mobile Station State Diagram

7 Although both normal and fast network re-entry processes are shown as transition from the Idle State to the Access
 8 State in Figure 2, there are differences that differentiate the two processes. The network re-entry is similar to
 9 network entry, except it may be shortened by the providing the target BS with MS information through paging
 10 controller or other network entity over the backhaul.

11 B.1.3 Overview of Physical Layer

12 B.1.3.1 Multiple Access Schemes

13 WirelessMAN-Advanced uses OFDMA as the multiple-access scheme in downlink and uplink. It further supports
 14 both TDD and FDD duplex schemes including H-FDD operation of the mobile stations in the FDD networks. The
 15 frame structure attributes and baseband processing are common for both duplex schemes. The OFDMA parameters
 16 are summarized in Table 1. Tone dropping at both edges of the frequency band based on 10 and 20 MHz systems
 17 can be used to support other bandwidths. In Table 1, TTG and RTG denote transmit/receive and receive/transmit
 18 transition gaps, respectively.

1 B.1.3.2 Frame Structure

2 A superframe is a collection of consecutive equally-sized radio frames whose beginning is marked with a
3 superframe header. The superframe header carries short-term and long-term system configuration information.

4 In order to decrease the air-link access latency, the radio frames are further divided into a number of subframes
5 where each subframe comprises of an integer number of OFDM symbols. The transmission time interval is defined
6 as the transmission latency over the air-link and is equal to a multiple of subframe length (default is one subframe).
7 There are four types of subframes: 1) type-1 subframe, which consists of six OFDM symbols, 2) type-2 subframe,
8 which consists of seven OFDM symbols, 3) type-3 subframe which consists of five OFDM symbols, and 4) type-4
9 subframe, which consists of nine OFDM symbols. In the basic frame structure shown in Figure 3, superframe length
10 is 20 ms (comprised of four radio frames), radio frame size is 5 ms (comprised of eight subframes), and subframe
11 length is 0.617 ms.

12

Table 1: OFDMA Parameters

Nominal channel bandwidth (MHz)	5	7	8.75	10	20		
Sampling factor	28/25	8/7	8/7	28/25	28/25		
Sampling frequency (MHz)	5.6	8	10	11.2	22.4		
FFT size	512	1024	1024	1024	2048		
Subcarrier spacing (kHz)	10.94	7.81	9.76	10.94	10.94		
Useful symbol time T_u (μ s)	91.429	128	102.4	91.429	91.429		
Symbol time T_s (μ s)	102.857	144	115.2	102.857	102.857		
CP $T_g=1/8 T_u$	FDD	Number of OFDM symbols per 5ms frame	48	34	43	48	
		Idle time (μ s)	62.857	104	46.40	62.857	62.857
	TDD	Number of OFDM symbols per 5ms frame	47	33	42	47	47
		TTG + RTG (μ s)	165.714	248	161.6	165.714	165.714
CP $T_g=1/16 T_u$	FDD	Number of OFDM symbols per 5ms frame	51	36	45	51	51
		Idle time (μ s)	45.71	104	104	45.71	45.71
	TDD	Number of OFDM symbols per 5ms frame	50	35	44	50	50
		TTG + RTG (μ s)	142.853	240	212.8	142.853	142.853
CP $T_g=1/4 T_u$	FDD	Number of OFDM symbols per 5ms frame	43	31	39	43	43
		Idle time (μ s)	85.694	40	8	85.694	85.694
	TDD	Number of OFDM symbols per 5ms frame	42	30	37	42	42
		TTG + RTG (μ s)	199.98	200	264	199.98	199.98

13 The concept of time zones applies to both TDD and FDD systems. These time zones are time-division multiplexed
14 across time domain in the DL to support both new and legacy mobile stations. For UL transmissions both time and
15 frequency-division multiplexing approaches can be used to support legacy and new terminals. The non-backward
16 compatible improvements and features are restricted to the new zones. All backward compatible features and
17 functions are used in the legacy zones.

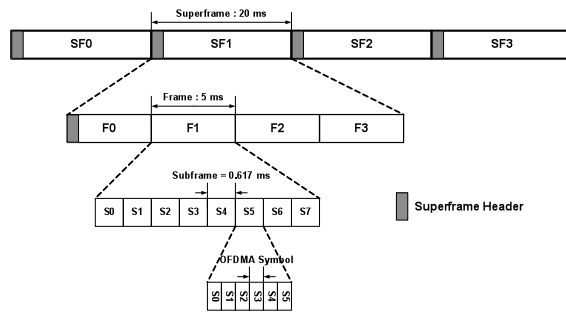

Figure 3: Basic Frame Structure

The support for multiple RF carriers can be accommodated with the same frame structure used for single carrier operation. All RF carriers are time aligned at the frame, subframe, and symbol level. Alternative frame structures for CP=1/16 and CP=1/4 are used that incorporate different number of OFDM symbols in certain subframes or different number of subframes per frame.

B.1.3.3 Physical and Logical Resource Blocks

The downlink/uplink subframes are divided into a number of frequency partitions, where each partition consists of a set of physical resource units over the available number of OFDM symbols in the subframe. Each frequency partition can include localized and/or distributed physical resource units. Frequency partitions can be used for different purposes such as fractional frequency reuse (FFR). The downlink/uplink resource partitioning and mapping is illustrated in Figure 4.

Wookbong 10/12/15 01:43 PM

Comment: typo

B.1.3.4 Downlink Symbol Structure

A physical resource unit (PRU) is the basic physical unit for resource allocation that comprises 18 contiguous subcarriers by N_{sym} contiguous OFDM symbols where N_{sym} is 6, 7 and 5-or-9 OFDM symbols for type-1, type-2, and type-3, and type-4 subframes, respectively. A logical resource unit (LRU) is the basic logical unit for distributed and localized resource allocations. A logical resource unit comprises of $18 \times N_{\text{sym}}$ subcarriers.

Wookbong 10/12/15 01:45 PM

Comment: modified from "or" to "and" for consistency

Wookbong 10/12/15 01:45 PM

Comment: modified

Distributed resource units (DRU) are used to achieve frequency diversity gain. A distributed resource unit contains a group of subcarriers which are spread across a frequency partition as shown in Figure 4. The size of the distributed resource units is equal to that of physical resource unit. Localized or contiguous resource units (CRU) are used to achieve frequency-selective scheduling gain. A localized resource unit comprises a group of subcarriers which are contiguous across frequency. The size of the localized resource units is equal to that of the physical resource units. To form distributed and localized resource units, the subcarriers over the OFDM symbols of a subframe are partitioned into guard and used subcarriers. The DC subcarrier is not used. The used subcarriers are divided into physical resource units. Each physical resource unit contains pilot and data subcarriers. The number of used pilot and data subcarriers depends on MIMO mode, rank and number of multiplexed MS, as well as the number of OFDM symbols within a subframe.

Jeongho Park 10/11/29 03:12 PM

Comment: Remove 9 symbols (type-4) in DL subframe

The PRUs are first subdivided into sub-bands and mini-bands where a sub-band comprises four adjacent PRUs and a mini-band comprises one PRU. The sub-bands are suitable for frequency selective allocations as they provide a contiguous allocation of PRUs in frequency. The mini-bands are suitable for frequency diverse allocations and are permuted in frequency. The downlink subcarrier to resource unit mapping process is defined as follows as illustrated in Figure 4.

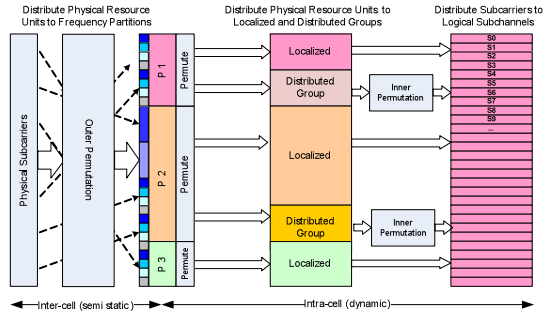

Figure 4: Illustration of the Downlink/Uplink Subcarrier to Resource Unit Mapping where P_i denotes the i th Frequency Partition

The subcarrier permutation defined for the downlink distributed resource allocations spreads the subcarriers of the DRU across all the distributed resource allocations within a frequency partition. After mapping all pilots, the remaining used subcarriers are used to define the DRUs. To allocate the LRUs, the remaining subcarriers are paired into contiguous subcarrier-pairs. Each LRU consists of a group of subcarrier-pairs.

B.1.3.5 Uplink Symbol Structure

Similar to the downlink symbol structure, a physical resource unit is defined as the basic physical unit for resource allocation that comprises 18 consecutive subcarriers by N_{sym} consecutive OFDM symbols where N_{sym} is 6, 7, 5 and 9 OFDM symbols for type-1, type-2, and type-3 and type-4 subframes respectively. A logical resource unit is the basic logical unit for distributed and localized resource allocations and its size is $18 \times N_{\text{sym}}$ subcarriers for data transmission. The subcarriers of an OFDM symbol are partitioned into $N_{\text{g,left}}$ left guard subcarriers, $N_{\text{g,right}}$ right guard subcarriers, and N_{used} used subcarriers. The DC subcarrier is not used. The N_{used} subcarriers are divided into PRUs. Each PRU contains pilot and data subcarriers. The number of pilot and data subcarriers depends on MIMO mode, rank and number of mobile stations multiplexed, and the type of resource allocation; i.e., distributed or localized resource allocations as well as the type of the subframe.

The uplink distributed units comprise a group of subcarriers which are spread over a frequency partition. The size of distributed unit is equal to logical resource blocks. The minimum unit for constructing a distributed resource unit is a tile. The uplink tile sizes are 6 subcarriers by $6N_{\text{sym}}$ OFDM symbols. The localized resource unit is used to achieve frequency-selective scheduling gain. A localized resource unit contains a group of subcarriers which are contiguous across frequency. The size of the localized resource unit equals the size of the logical resource units for localized allocations, i.e., 18 subcarriers by $6N_{\text{sym}}$ OFDM symbols.

The PRUs are first subdivided into sub-bands and mini-bands, where a sub-band comprises N_1 adjacent PRUs and a mini-band consists of N_2 adjacent PRUs, where $N_1 = 4$ and $N_2 = 1$. The sub-bands are suitable for frequency selective allocations whereas the mini-bands are suitable for frequency diversity allocation and are permuted in frequency. The main features of resource mapping include support of CRUs and DRUs by frequency-division multiplexing, DRUs comprising multiple tiles which are spread across the distributed resource allocations to obtain frequency diversity gain, and FFR may be applied in the uplink. The uplink resource unit mapping process is illustrated in Figure 4. An inner permutation is defined for the uplink distributed resource allocations that spreads DRU tiles across the entire distributed resource allocations within a frequency partition. Each DRU in an uplink frequency partition is divided into 3 tiles of 6 adjacent subcarriers over N_{sym} symbols. The tiles within a frequency partition are collectively tile-permuted to obtain frequency diversity gain across the allocated resources.

The WirelessMAN-Advanced uplink physical structure supports both frequency and time division multiplexing of the new and the legacy system. A symbol structure based on the new PUSC subchannelization should be used in

Jeongho Park 10/11/29 03:13 PM

Comment: Put 9 symbol type-4 subframe type in UL

Wookbong 10/12/15 01:46 PM

Comment: modified

Wookbong 10/12/15 01:46 PM

Comment: modified

1 order to provide FDM-based legacy support. In that case, unlike the distributed structure, the new PUSC contains six
 2 tiles of 4 subcarriers by 6 symbols as shown in Figure 5.

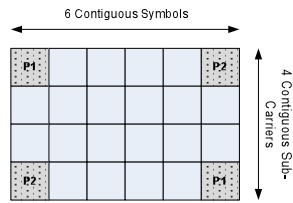

3
 4 Figure 5: New Uplink PUSC Structure for two Streams

5 B.1.3.6 Modulation and Coding

6 The performance of adaptive modulation generally suffers from the power inefficiencies of multilevel modulation
 7 schemes. This is due to the variations in bit reliabilities caused by the bit-mapping onto the signal constellation. To
 8 overcome this issue, a constellation-rearrangement scheme is utilized where signal constellation of QAM signals
 9 between retransmissions is rearranged; i.e., the mapping of the bits into the complex-valued symbols between
 10 successive HARQ retransmissions is changed, resulting in averaging bit reliabilities over several retransmissions
 11 and lower packet error rates. The mapping of bits to the constellation point depends on the constellation-
 12 rearrangement type used for HARQ re-transmissions and may also depend on the MIMO scheme. The complex-
 13 valued modulated symbols are mapped to the input of the MIMO encoder. Incremental redundancy HARQ is used in
 14 by determining the starting position of the bit selection for HARQ retransmissions.

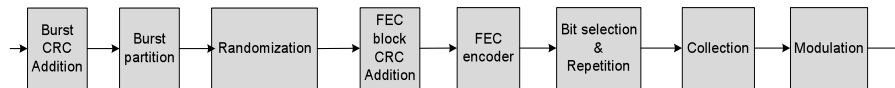

15
 16 Figure 6: Coding and Modulation Procedures

17 Figure 6 shows the channel coding and modulation procedures. A cyclic redundancy check (CRC) is appended to a
 18 burst (i.e., a physical layer data unit) prior to partitioning. The 16-bit CRC is calculated over the entire bits in the
 19 burst. If the burst size including burst CRC exceeds the maximum FEC block size, the burst is partitioned into K_{FB}
 20 FEC blocks, each of which is encoded separately. If a burst is partitioned into more than one forward error
 21 correction (FEC) blocks, a FEC block CRC is appended to each FEC block before the FEC encoding. The FEC
 22 block CRC of a FEC block is calculated based on the entire bits in that FEC block. Each partitioned FEC block
 23 including 16-bit FEC block CRC has the same length. The maximum FEC block size is 4800 bits. Concatenation
 24 rules are based on the number of information bits and do not depend on the structure of the resource allocation
 25 (number of logical resource units and their size). The IEEE WirelessMAN-Advanced utilizes the convolutional
 26 turbo code (CTC) with code rate of 1/3. The CTC scheme is extended to support additional FEC block sizes.
 27 Furthermore, the FEC block sizes can be regularly increased with predetermined block size resolutions. The FEC
 28 block sizes which are multiple of seven are removed for the tail-biting encoding structure. The encoder block
 29 depicted in Figure 7 includes the interleaver.

30 Bit selection and repetition are used in WirelessMAN-Advanced to achieve rate matching. Bit selection adapts the
 31 number of coded-bits to the size of the resource allocation which may vary depending on the resource unit size and
 32 subframe type. The total subcarriers in the allocated resource unit are segmented to each FEC block. The total
 33 number of information and parity bits generated by FEC encoder are considered as the maximum size of circular
 34 buffer. Repetition is performed when the number of transmitted bits is larger than the number of selected bits. The
 35 selection of coded bits is done cyclically over the buffer. The mother-code bits, the total number of information and
 36 parity bits generated by FEC encoder, are considered as a maximum size of circular buffer. In case that the size of

1 the circular buffer N_{buffer} is smaller than the number of mother-code bits, the first N_{buffer} bits of mother-code bits are
2 considered as selected bits.

3 Modulation constellations of QPSK, 16QAM, and 64QAM are supported. The mapping of bits to the constellation
4 point depends on the constellation-rearrangement (CoRe) version used for HARQ retransmission as described and
5 further depends on the MIMO scheme. The QAM symbols are mapped into the input of the MIMO encoder. The
6 sizes include the addition of CRC (per burst and per FEC block), if applicable. Other sizes require padding to the
7 next burst size. The code rate and modulation depend on the burst size and the resource allocation.
8

9 Incremental redundancy HARQ (HARQ-IR) is used in WirelessMAN-Advanced by determining the starting
10 position of the bit selection for HARQ retransmissions. Chase combining HARQ (HARQ-CC) is also supported and
11 considered as a special case of HARQ-IR. The 2-bit sub-packet identifier (SPID) is used to identify the starting
12 position. The CoRe scheme can be expressed by a bit-level interleaver. The resource allocation and transmission
13 formats in each retransmission in the downlink can be adapted with control signalling. The resource allocation in
14 each retransmission in the uplink can be fixed or adaptive according to control signalling. In HARQ re-
15 transmissions, the bits or symbols can be transmitted in a different order to exploit the frequency diversity of the
16 channel. For HARQ retransmission, the mapping of bits or modulated symbols to spatial streams may be applied to
17 exploit spatial diversity with given mapping pattern, depending on the type of HARQ-IR. In this case, the predefined
18 set of mapping patterns should be known to the transmitter and receiver. In downlink HARQ, the BS may transmit
19 coded bits exceeding current available soft buffer capacity.

20 B.1.3.7 Pilot Structure

21 B.1.3.7.1 Downlink Pilot Structure

22 Transmission of pilot subcarriers in the downlink is necessary to allow channel estimation, channel quality
23 measurement (e.g., CQI), frequency offset estimation, etc. To optimize the system performance in different
24 propagation environments, WirelessMAN-Advanced supports both common and dedicated pilot structures. The
25 classification of pilots into common and dedicated is done based on their usage. The common pilots can be used in
26 distributed allocation by all mobile stations. Dedicated pilots can be used with both localized and distributed
27 allocations. ~~They are associated to user specific pilot index. The dedicated pilots are associated with a specific~~
28 ~~resource allocation, are intended to be used by the MSs allocated to specific resource allocation, and therefore shall~~
29 ~~be precoded or beamformed in the same way as the data subcarriers of the resource allocation. Pilot subcarriers that~~
30 ~~can be used only by a group of mobile stations within an FFR group are a special case of common pilots. The~~
31 ~~dedicated pilots are associated with a specific FFR group and can be only used by the mobile stations assigned to~~
32 ~~that group; therefore, they can be precoded or beam-formed similar to the data subcarriers.~~ The pilot structure is
33 defined for up to eight streams and there is a unified design for common and dedicated pilots. There is equal pilot
34 density per spatial stream; however, there is not necessarily equal pilot density per OFDM symbols. ~~Here is the~~
35 ~~same number of pilots for each physical resource unit allocated to a particular mobile station.~~

Jeongho Park 10/12/2 02:16 PM

Comment: clarification

Jeongho Park 10/11/29 04:00 PM

Comment: Dedicated pilots can be used in SLRU and NLRU. They are associated to user specific pilot index.

Wookbong 10/12/15 01:48 PM

Comment: More explanation.

Jeongho Park 10/12/2 02:17 PM

Comment: Text is ambiguous and bring confusion

Jeongho Park 10/12/2 02:18 PM

Comment: Text is ambiguous and bring confusion

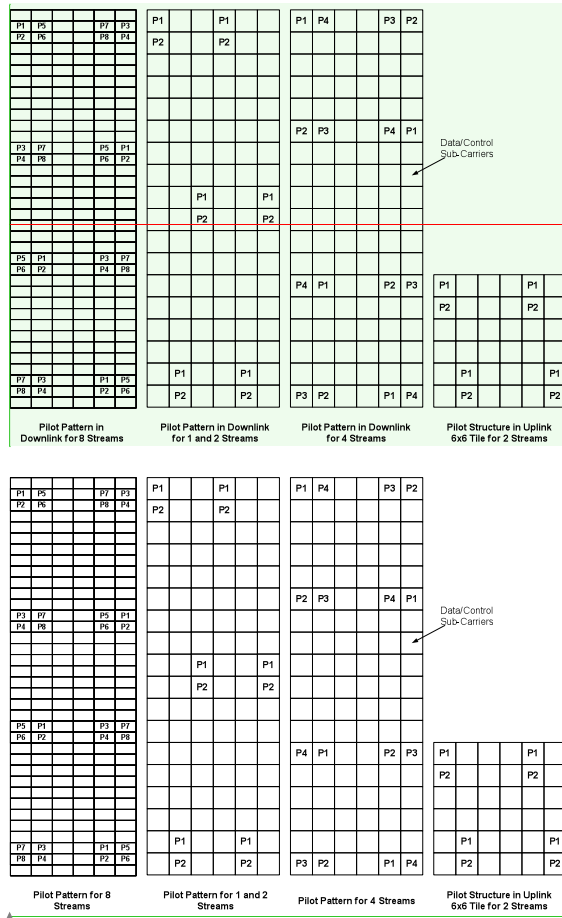

Jeongho Park 10/12/2 02:20 PM
Comment: The first three figures can be applied to UL cases, either. Delete this figure and use the next figure instead.

Unknown
Field Code Changed

Figure 7: Downlink/Uplink Pilot Structures for 1, 2, 4, and 8 Streams for Type-1 Subframe

For the subframe consisting of 5 OFDM symbols, the last OFDM symbol is deleted. For the subframe consisting of 7 OFDM symbols, the first OFDM symbol is added as the 7th OFDM symbol. For the subframe consisting of 5 or 7 OFDM symbols, one of OFDM symbols is deleted or repeated. To overcome the effects of pilot interference among the neighbouring sectors or base stations, an interlaced pilot structure is utilized by cyclically shifting the base pilot pattern such that the pilots of neighbouring cells do not overlap.

Wookbong 10/12/15 01:49 PM
Comment: Clear description is required.

B.1.3.7.2 Uplink Pilot Structure

The uplink pilots are dedicated to localized and distributed resource units and are precoded using the same precoding as the data subcarriers of the resource allocation. The pilot structure is defined for up to 4 spatial transmit streams for SU-MIMO and up to 8 streams for CSM, with orthogonal patterns. The pilot pattern may support variable pilot power boosting. When pilots are power-boosted, each data subcarrier should have the same transmission power across all OFDM symbols in a resource block. The 18x6 uplink resource blocks use the same

Wookbong 10/12/15 01:51 PM
Comment: Need to be changed in this way.

1 pilot patterns as the downlink counterpart ~~for up to 4 spatial streams~~. The pilot pattern for 6×6 tile structure is
 2 different and it is shown in Figure 57.

3 B.1.3.8 Control Channels

4 Downlink control channels carry essential information for system operation. Depending on the type of control
 5 signalling, information is transmitted over different time intervals (i.e., from superframe to subframe intervals). The
 6 system configuration parameters are transmitted at the superframe intervals, whereas control signalling related to
 7 user data allocations is transmitted at the frame/subframe intervals.

8 B.1.3.8.1 Downlink Control Channels

9 Superframe Header

10 The superframe header carries essential system parameters and configuration information. The content of
 11 superframe header is divided into two segments; i.e., primary and secondary superframe headers. ~~The information~~
 12 ~~transmitted in secondary superframe header is further divided into different sub-packets.~~ The primary superframe
 13 header is transmitted every superframe, whereas the secondary superframe header is transmitted over one or more
 14 superframes. The primary and secondary superframe headers are located in the first subframe within a superframe
 15 and are time-division-multiplexed with the advanced preamble. The superframe header occupies ~~narrower~~
 16 ~~bandwidth relative to the system bandwidth (i.e., no more than 5 MHz bandwidth).~~ The primary superframe header
 17 is transmitted using predetermined modulation and coding scheme. The secondary superframe header is transmitted
 18 using predetermined modulation scheme while its repetition coding factor is signalled in the primary superframe
 19 header. The primary and secondary superframe headers are transmitted using two spatial streams and space-
 20 frequency block coding to improve coverage and reliability. The MS is not required to know the antenna
 21 configuration prior to decoding the primary superframe header. The information transmitted in the secondary
 22 superframe header is divided into different sub-packets. The secondary superframe header sub-packet 1 (SP1)
 23 includes information needed for network re-entry. The secondary superframe header sub-packet 2 (SP2) contains
 24 information for initial network entry. The secondary superframe header sub-packet 3 (SP3) contains remaining
 25 system information for maintaining communication with the BS.

26 Advanced MAP (A-MAP)

27 The advanced MAP (i.e., unicast control information) consists of both user-specific and non-user-specific control
 28 information. Non-user-specific control information includes information that is not dedicated to a specific user ~~nor~~
 29 specific group of users. It contains information required to decode user-specific control signalling. User specific
 30 control information consists of information intended for one or more users. It includes scheduling assignment, power
 31 control information, and HARQ feedback. Resources can be allocated persistently to the mobile stations. ~~The~~
 32 ~~periodicity of the allocation is configurable.~~ Group control information is used to allocate resources and/or configure
 33 resources to one or multiple mobile stations within a user group. ~~Each group is associated with a set of resources.~~
 34 ~~Voice over IP (VoIP) is an example of the class of services that can take advantage of group messages.~~ Within a
 35 subframe, control and data channels are frequency-division-multiplexed. Both control and data channels are
 36 transmitted on logical resource units that span over all OFDM symbols within a subframe.

37 Each DL subframe contains a control region including both non-user-specific and user-specific control information.
 38 All advanced MAPs share a ~~physical~~ time-frequency region known as A-MAP region. The control regions are
 39 located in every subframe. The corresponding UL allocations occurs L subframes later, where L is determined by A-
 40 MAP relevance. ~~The coding rate is predetermined for non-user-specific information while it is indicated by~~
 41 ~~superframe header for user-specific control information.~~ ~~The coding rate of the control blocks is known to the MS~~
 42 ~~through group size indication in non-user-specific control information in order to reduce the complexity of blind~~
 43 ~~detection by the MS.~~

44 An advanced MAP (A-MAP) ~~allocation~~ Information Element (IE) is defined as the basic element of unicast service
 45 control. A unicast control IE may be addressed to one user using a unicast identifier or to multiple users using a
 46 multicast/broadcast identifier. The identifier is masked with CRC in the advanced MAP allocation information
 47 element. It may contain information related to resource allocation, HARQ, MIMO transmission mode, etc. Each ~~A-~~

Jeongho Park 10/11/29 04:04 PM

Comment: 7

Jeongho Park 10/12/2 02:00 PM

Formatted: Font color: Red, Strikethrough

Jeongho Park 10/12/2 02:00 PM

Formatted: Underline, Font color: Blue

Jeongho Park 10/12/2 02:33 PM

Comment: This sentence is redundant.

Jeongho Park 10/12/2 02:37 PM

Comment: Not necessary and make readers confused if system BW is 5MHz.

Jeongho Park 10/12/2 02:47 PM

Comment: Not very necessary to explain P.A.

Jeongho Park 10/12/2 02:47 PM

Comment: Not very necessary to explain G.R.A

Wookbong 10/12/15 01:52 PM

Comment: Don't need this

1 ~~MAP~~unicast control information element is coded separately. Non-user-specific control information is encoded
 2 separately from the user-specific control information. ~~The transmission format of non-user specific control~~
 3 ~~information is predetermined.~~ In the DL subframes, ~~each frequency partition for reuse-1 and/or frequency partition~~
 4 ~~for power-boostered reuse-3~~ may contain an A-MAP region. The A-MAP region occupies the first few distributed
 5 resource units in a frequency partition. The structure of an A-MAP region is illustrated in Figure 8. The resource
 6 occupied by each A-MAP physical channel may vary depending on the system configuration and scheduler
 7 operation. There are different types of A-MAPs as follows:

Jeongho Park 10/12/2 03:49 PM
 Comment: Correction of wrong contents

8 - **Assignment A-MAP** contains resource assignment information which is categorized into multiple types of
 9 resource assignment IEs (assignment A-MAP IE). ~~Each assignment A-MAP IE is coded separately and carries~~
 10 ~~information for one or a group of users.~~ The minimum logical resource unit in the assignment A-MAP
 11 consists of 56 data tones. Assignment A-MAP IEs with less than 40 bits are zero-padded to 40 bits.
 12 Assignment A-MAP IEs with more than 40 bits are divided into several segmented IEs, each with 40 bits.
 13 Segments of an assignment A-MAP IE are separately coded and modulated and occupy a number of
 14 logically contiguous resource units. Assignment A-MAP IEs are grouped together based on same channel
 15 coding rate ~~after separate channel encoding of each IE~~. Assignment A-MAP IEs in the same group are
 16 transmitted in the same frequency partition with the same channel coding rate. Each assignment A-MAP
 17 group ~~contains~~may occupy several logically contiguous resource units. The number of assignment A-MAP
 18 IEs in each assignment A-MAP group is signalled through non-user specific A-MAP in the same subframe.
 19 If two assignment A-MAP groups using two channel coding rates are present in an A-MAP region, assignment
 20 A-MAP group using lower channel coding rate is allocated first, followed by assignment A-MAP
 21 group using higher channel coding rate. ~~The maximum number of assignment A-MAP IEs in one subframe~~
 22 ~~that the BS may allocate to an MS is 8. This number includes all of the assignment A-MAP IEs that are~~
 23 ~~required to be considered by the MS.~~ For a segmentable assignment A-MAP IE (i.e., an assignment A-
 24 MAP IE that occupies more than one minimum logical resource unit using QPSK 1/2), each segment is
 25 counted as one assignment A-MAP IE.

Jeongho Park 10/12/2 03:50 PM
 Comment: Redundant

- 26 - **HARQ Feedback A-MAP** contains HARQ ACK/NACK information for UL data transmission.
- 27 - **Power Control A-MAP** includes fast power control command to mobile stations.

Jeongho Park 10/12/13 06:07 PM
 Comment: Can be removed because it is too specific (considering balancing of level with other parts)

28 There are different assignment A-MAP IE types that distinguish between DL/UL, persistent/non-persistent, single
 29 user/group resource allocation, basic/extended IE scenarios. Different types of assignment A-MAPs and their usage
 30 are shown in Table 2.

Table 2: Assignment A-MAP IE Types and Their Usage

Assignment A-MAP IE Type	Usage
DL Basic Assignment	Allocation information for MS to decode DL bursts using continuous contiguous logical resources
UL Basic Assignment	Allocation information for MS to transmit UL bursts using continuous contiguous logical resources
DL Sub-band Assignment	Allocation information for MS to decode DL bursts using sub-band based resources
UL Sub-band Assignment	Allocation information for MS to transmit UL bursts using sub-band based resources
Feedback Allocation	Allocation or de-allocation of UL fast feedback control channels to an MS
UL Sounding Command	Control information for MS to start request UL sounding transmission
CDMA Allocation	Allocation for MS requesting bandwidth using a ranging or bandwidth request codes
DL Persistent	DL persistent resource allocation
UL Persistent	UL persistent resource allocation
Group Resource Allocation	Group scheduling and resource allocation
Feedback Polling	Allocation for MS to send MIMO feedback using MAC messages or extended signalling headers
BR-ACK	Indication of decoding status of bandwidth request opportunities and resource allocation of bandwidth

Jeongho Park 10/12/13 06:09 PM
 Comment: [editorial] Because 'continuous' has time domain feeling, contiguous seems better

Wookbong 10/12/15 01:53 PM
 Comment: It is used for start/modify/stop etc.

Wookbong 10/12/15 01:54 PM
 Comment: Changed to signalling header

	request header
Broadcast	Broadcast burst allocation and other broadcast information

1

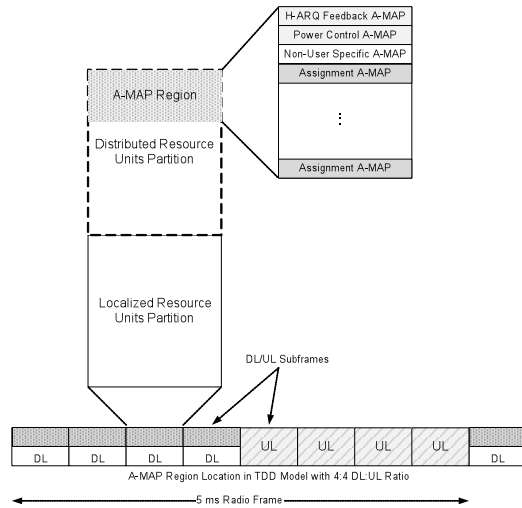

2

3

Figure 8: A-MAP Location and Structure (Example)

4 B.1.3.8.2 Uplink Control Channels

5 MIMO Feedback

6 MIMO feedback provides wideband and/or narrowband spatial characteristics of the channel that are required for
 7 MIMO operation. The MIMO mode, precoding matrix index, rank adaptation information, channel covariance
 8 matrix elements, ~~power loading factor~~, ~~eigenvectors~~ and ~~best subband index~~ ~~channel sounding~~ are examples of
 9 MIMO feedback information.

10 HARQ Feedback

11 HARQ feedback (ACK/NACK) is used to acknowledge downlink data transmissions. The uplink HARQ feedback
 12 channel starts at a predetermined offset with respect to the corresponding downlink transmission. The HARQ
 13 feedback channel is frequency-division-multiplexed with other control and data channels. Orthogonal codes are used
 14 to multiplex multiple HARQ feedback channels. The HARQ feedback channel comprises three distributed mini-
 15 tiles.

16 Bandwidth Request

17 Bandwidth requests are used to indicate the amount of bandwidth required by a user. Bandwidth requests are
 18 transmitted through indicators or messages. A bandwidth request indicator notifies the base station of an uplink
 19 grant request by the mobile station sending the indicator. Bandwidth request messages can include information
 20 about the status of queued traffic at the mobile station such as buffer size and quality of service parameters.
 21 Contention or non-contention based random access is used to transmit bandwidth request information on this control
 22 channel. The contention-based bandwidth request procedure is illustrated in Figure 9. A 5-step regular procedure or
 23 an optional 3-step quick access procedure is utilized. Steps 2 and 3 can be skipped in a quick access procedure. In

1 step 1, the MS sends a bandwidth request (BW-REQ) indicator for quick access that may indicate information such
 2 as MS addressing and/or request size and/or uplink transmit power report, and/or QoS parameters, and the BS may
 3 allocate uplink grant based on certain policy.

4

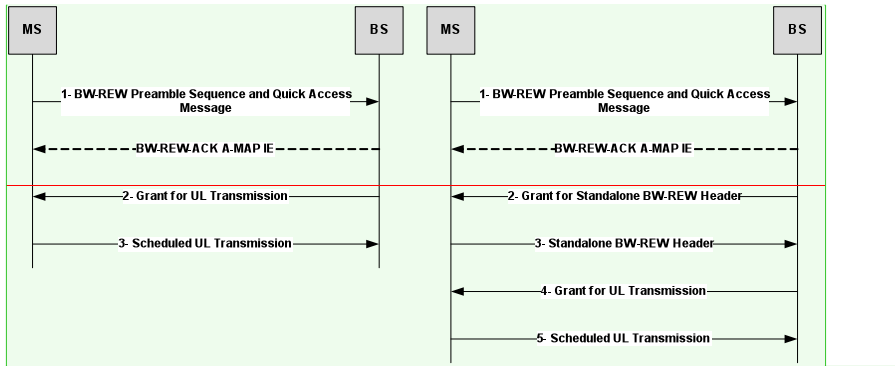

Jeongho Park 10/12/2 04:50 PM
Comment: Typo correction, 5 step procedure clarification, BR ACK A_MAP IE or CDMA alloc IE can be used (for D10). Delete this figure and use the next figure

5

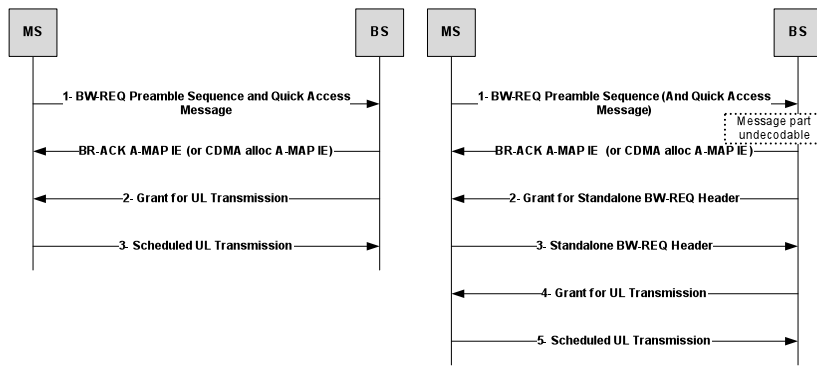

6

7

Figure 9: Bandwidth Request Procedure

8 The bandwidth request channel starts at a configurable location with the configuration defined in a downlink
 9 broadcast control message. The bandwidth request channel is frequency-division-multiplexed with other uplink
 10 control and data channels. A BW-REQ tile is defined as 6 subcarriers by 6 OFDM symbols. Each BW-REQ channel
 11 consists of 3 distributed BW-REQ tiles. Multiple bandwidth request indicators can be transmitted on the same BW-
 12 REQ channel using code-division multiplexing.

13 **Channel Quality Indicators**

14 Channel quality feedback provides information about channel conditions as seen by the user. This information is
 15 used by the base station for link adaptation, resource allocation, power control, etc. The channel quality
 16 measurement includes both narrowband and wideband measurements. The CQI feedback overhead can be reduced
 17 through differential feedback or other compression techniques. Examples of CQI include physical effective carrier to
 18 interference plus noise ratio (CINR), ~~effective CINR~~, band selection, etc.

Wookbong 10/12/15 01:54 PM
Comment: Only effective CINR

19 The default subframe size for transmission of uplink control information is 6 symbols. The fast feedback channel
 20 carries channel quality feedback and MIMO feedback. There are two types of uplink fast feedback control channels:
 21 a) primary and b) secondary fast feedback channels. ~~The primary fast feedback channel provides wideband feedback~~

1 ~~information including channel quality and MIMO feedback. The secondary fast feedback control channel carries~~
 2 ~~narrowband CQI and MIMO feedback information.~~ The secondary fast feedback channel can be used to support CQI
 3 reporting at higher code rate and thus more CQI information bits. The fast feedback channel is frequency-division-
 4 multiplexed with other uplink control and data channels.

Wookbong 10/12/15 01:55 PM

Comment: This is not true.

5 The fast feedback channel starts at a predetermined location, with the size defined in a downlink broadcast control
 6 message. Fast feedback allocations to a mobile station can be periodic and the allocations are configurable. ~~For~~
 7 ~~periodic allocations, the~~ The specific type of feedback information carried on each fast feedback opportunity can be
 8 different. ~~The secondary fast feedback channel can be allocated in a non-periodic manner based on traffic or channel~~
 9 ~~conditions.~~ The number of bits carried in the fast feedback channel can be adaptive. For efficient transmission of
 10 feedback channels a mini-tile is defined comprising 2 subcarriers by 6 OFDM symbols. One logical resource unit
 11 consists of 9 mini-tiles and can be shared by multiple fast feedback channels.

Wookbong 10/12/15 01:56 PM

Comment: This is not true.

12 Uplink Sounding Channel

13 The sounding channel is used by a user terminal to transmit sounding reference signals to enable the base station to
 14 measure uplink channel conditions. The sounding channel may occupy either specific uplink sub-bands or the entire
 15 bandwidth over an OFDM symbol. The base station can configure a mobile station to transmit the uplink sounding
 16 signal over predefined subcarriers within specific sub-bands or the entire bandwidth. The sounding channel is
 17 orthogonally multiplexed (in time or frequency) with other control and data channels. Furthermore, the base station
 18 can configure multiple user terminals to transmit sounding signals on the corresponding sounding channels using
 19 code-, frequency-, or time-division multiplexing. Power control for the sounding channel can be utilized to adjust
 20 the sounding quality. The transmit power from each mobile terminal may be separately controlled according to
 21 certain CINR target values.

22 Ranging Channel

23 The ranging channel is used for uplink synchronization. The ranging channel can be further classified into ranging
 24 for non-synchronized and synchronized mobile stations. [The ranging channel for non-synchronized mobile](#)
 25 [station\(NS-RCH\) is used for initial network entry and for handover to a target BS. The ranging channel for](#)
 26 [synchronized mobile station\(S-RCH\) is used for periodic ranging. In a femtocell, mobile stations shall perform](#)
 27 [initial ranging, handover ranging, and periodic ranging by using the S-RCH.](#)

28 ~~The ranging channel structures for non-synchronized mobile stations are shown in Figure 10. A random access~~
 29 ~~procedure, which can be contention or non-contention based is used for ranging. The contention-based random~~
 30 ~~access is used for initial ranging. The non-contention based random access is used for periodic ranging and~~
 31 ~~handover. The ranging channel for non-synchronized mobile stations starts at a configurable location with the~~
 32 ~~configuration signalled in a downlink broadcast control message. The ranging channel for non-synchronized mobile~~
 33 ~~stations is frequency-division multiplexed with other uplink control and data channels.~~

34 ~~The ranging channel for non-synchronized mobile stations consists of three fields: 1) ranging cyclic prefix (RCP), 2)~~
 35 ~~ranging preamble (RP), and 3) guard time (GT). The length of RCP is longer than the sum of the maximum delay~~
 36 ~~spread and round trip delay of supported cell size. The length of GT is chosen longer than the round trip delay of the~~
 37 ~~supported cell size. The length of ranging preamble is chosen equal to or longer than the length of RCP. To support~~
 38 ~~large cell sizes, the ranging channel for non-synchronized user terminals can span multiple concatenated subframes.~~
 39 ~~Figure 11 shows the default ranging channel structure over one subframe. A single preamble can be used by~~
 40 ~~different non-synchronized users for increasing ranging opportunities. When the preamble is repeated as a single~~
 41 ~~opportunity, the second RCP can be omitted for coverage extension. A number of guard subcarriers are reserved at~~
 42 ~~the edges of non-synchronized ranging channel physical resource.~~

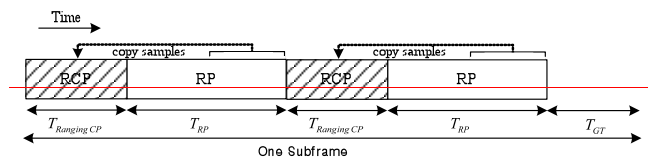

43

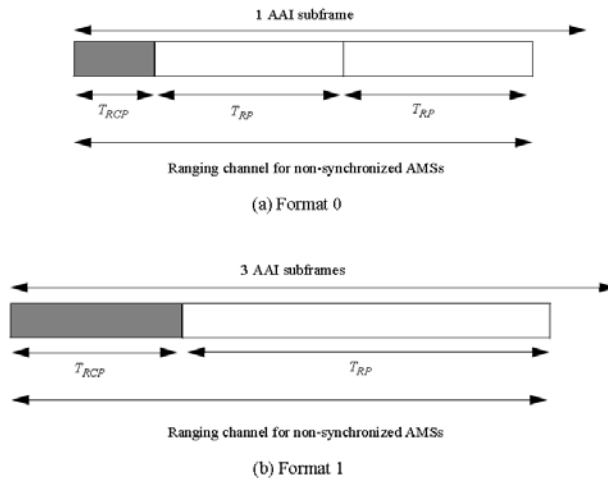

Figure 10: Ranging Channel Structure for Non-synchronized Access

When multi-antenna transmission is supported by mobile station, it can be used to increase the ranging opportunity by using spatial multiplexing. The ranging channel for synchronized mobile stations is used for periodic ranging. The ranging channel for synchronized user terminals starts at a configurable location with the configuration signalled in a downlink broadcast control message. The ranging channel for synchronized mobile stations is frequency-division multiplexed with other uplink control and data channels.

Power Control

Power control mechanism is supported for downlink and uplink. The base station controls the transmit power per subframe and per user. Using downlink power control, user-specific information with dedicated pilot is received by the terminal with the controlled power level. The downlink advanced MAPs can be are power-controlled based on the terminal uplink channel quality feedback. The per-pilot-subcarrier power and the per-data-subcarrier power can jointly be adjusted for adaptive downlink power control. In the case of dedicated pilots this is done on a per-user basis and in the case of common pilots this is done jointly for the users sharing the pilots.

The uplink power control is supported to compensate the path loss, shadowing, fast fading and implementation loss as well as to mitigate inter-cell and intra-cell interference. The uplink power control includes open-loop and closed-loop power control mechanisms. The base station can transmit necessary information through control channel or message to terminals to support uplink power control. The parameters of power control algorithm are optimized on system-wide basis by the base station and broadcasted periodically or triggered by certain events.

In high mobility scenarios, power control scheme may not be able to compensate the fast fading channel effect because of the variations of the channel impulse response. As a result, the power control is used to compensate the distance-dependent path loss, shadowing and implementation loss only.

The channel variations and implementation loss are compensated via open-loop power control without frequently interacting with the base station. The terminal can determine the transmit power based on the transmission parameters sent by the serving base station, uplink channel transmission quality, downlink channel state information, and interference knowledge obtained from downlink. Open-loop power control provides a coarse initial power setting of the terminal when an initial connection is established.

The dynamic channel variations are compensated via closed-loop power control with power control commands from the serving base station. The base station measures uplink channel state and interference information using uplink

1 data and/or control channel transmissions and sends power control commands to the terminal. The terminal adjusts
 2 its transmission power based on the power control commands from the base station.

3 **B.1.3.9 Downlink Synchronization (Advanced Preamble)**

4 WirelessMAN-Advanced utilizes a new hierarchical structure for the DL synchronization where two sets of
 5 preambles, **primary advanced preamble (PA-Preamble)** and **secondary advanced preamble (SA-Preamble)** at
 6 **superframe and frame intervals** are transmitted (Figure 11). **The first set of preamble sequences mark the beginning**
 7 **of the superframe and are common to a group of sectors or cells.** One PA-Preamble symbol and two SA-Preamble
 8 symbols exist within the superframe. The location of the A-Preamble symbol is specified as the first symbol of
 9 frame except for the last frame. PA-Preamble is located at the first symbol of second frame in a superframe while
 10 SA-Preamble is located at the first symbol of the first and the third frames. The PA-Preamble **primary advanced**
 11 **preamble** carries information about system bandwidth and carrier configuration. The **PA-Preamble primary**
 12 **advanced preamble** has a fixed bandwidth of 5 MHz and can be used to facilitate location-based services. A
 13 frequency reuse of one is applied to the **PA-Preamble primary advanced preamble** in frequency domain. SA-
 14 **Preamble** **The second set of advanced preamble sequences (secondary advanced preamble)** is repeated every two
 15 frames and spans the entire system bandwidth and carries the cell ID. A frequency reuse of three is used for this set
 16 of sequences to mitigate inter-cell interference. **The secondary advanced preambles carry SA-Preamble carries 768**
 17 **distinct cell IDs.** **The set of SA-Preamble Secondary advanced preamble sequences are** is partitioned and each
 18 partition is dedicated to specific BS type such as macro BS, femto BS, etc. **The partition information is broadcast in**
 19 **the secondary superframe header and AAI-SCD message.** **The partition information is broadcast in the secondary**
 20 **superframe header.**

Jeongho Park 10/12/13 02:04 PM

Comment: Correct the wrong sentence and picture

Wookbong 10/12/15 01:58 PM

Comment: SCD also

21

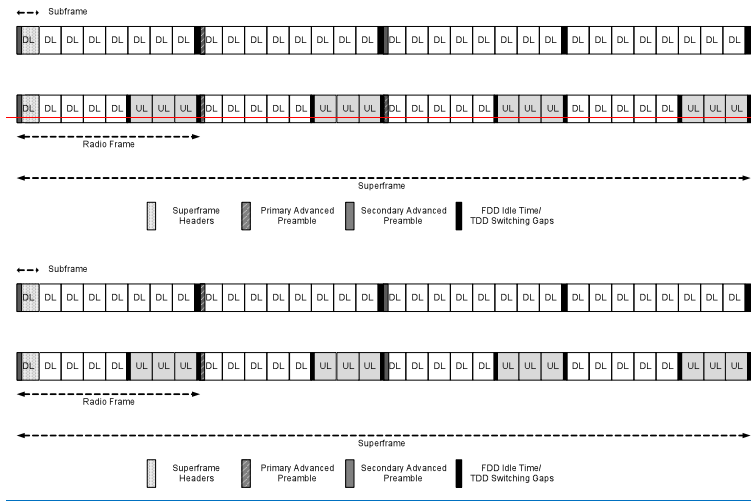

22

23

24 **B.1.3.10 Multi-Antenna Techniques in WirelessMAN-Advanced**

25 **B.1.3.10.1 Downlink MIMO Structure**

26 WirelessMAN-Advanced supports several advanced multi-antenna techniques including single and multi-user
 27 MIMO (spatial multiplexing and beamforming) as well as a number of transmit diversity schemes. In single-user
 28 MIMO (SU-MIMO) scheme only one user can be scheduled over one (time, frequency, space) resource unit. In
 29 multi-user MIMO (MU-MIMO), on the other hand, multiple users can be scheduled in one resource unit. Vertical
 30 encoding (**or single codeword**) utilizes one encoder block (or layer), whereas **horizontal multi-layer** encoding (**or**

1 **multi-codeword**) uses multiple encoders (or multiple layers). A layer is defined as a coding and modulation input
 2 path to the MIMO encoder. A stream is defined as the output of the MIMO encoder that is further processed through
 3 the beamforming or the precoder block. For spatial multiplexing, the rank is defined as the number of streams to be
 4 used for the user. **Each SU-MIMO or MU-MIMO open-loop or closed-loop schemes is defined as a MIMO mode:**

Wookbong 10/12/15 01:58 PM
 Comment: Correct according to current standard

Jeongho Park 10/12/13 02:06 PM
 Comment: redundant

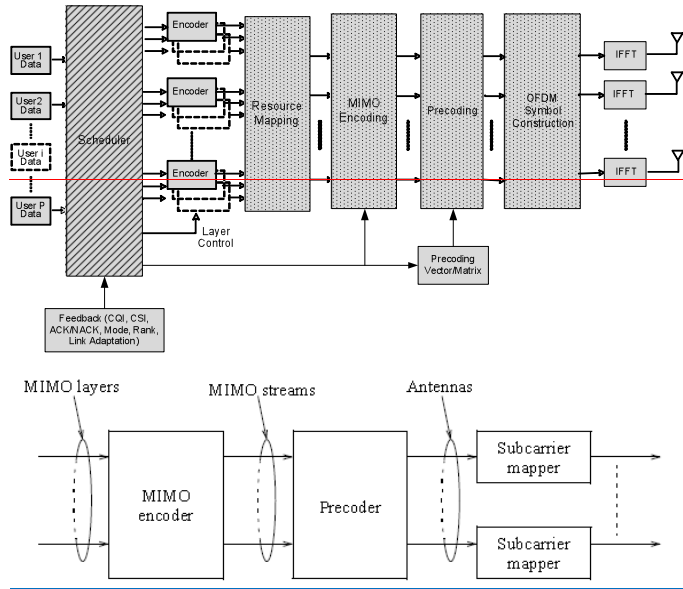

Figure 12: Illustration of Downlink MIMO Structure

9 The DL MIMO transmitter structure is shown in Figure 12. The encoder block contains the channel encoder,
 10 interleaving, rate-matching, and modulating blocks per layer. The resource mapping block maps the complex-valued
 11 modulation symbols to the corresponding time-frequency resources. The MIMO encoder block maps the layers onto
 12 the streams, which are further processed through the precoder block. The precoder block maps the streams to
 13 antennas by generating the antenna-specific data symbols according to the selected MIMO mode. The OFDM
 14 symbol construction block maps antenna-specific data to the OFDM symbols. The feedback block contains feedback
 15 information such as CQI or channel state information (CSI) from the MS. Table 3 contains information on various
 16 MIMO modes supported by the WirelessMAN-Advanced.

Table 3: DL MIMO Modes

Mode Index	Description	MIMO Encoding Format	MIMO Precoding
Mode 0	Open-Loop SU-MIMO (TX Diversity)	SFBC	Non-Adaptive
Mode 1	Open-Loop SU-MIMO (Spatial Multiplexing)	Vertical Encoding	Non-Adaptive
Mode 2	Closed-Loop SU-MIMO (Spatial Multiplexing)	Vertical Encoding	Adaptive
Mode 3	Open-Loop MU-MIMO (Spatial Multiplexing)	Horizontal Multi-layer Encoding	Non-Adaptive
Mode 4	Closed-Loop MU-MIMO (Spatial Multiplexing)	Horizontal Multi-layer Encoding	Adaptive
Mode 5	Open-Loop SU-MIMO (TX Diversity)	Conjugate Data Repetition	Non-Adaptive

Wookbong 10/12/15 01:59 PM
 Comment: Change according to current standard.

1 The minimum antenna configuration in the DL and UL is 2x2 and 1x2, respectively. For open-loop spatial
 2 multiplexing and closed-loop SU-MIMO, the number of streams is constrained to the minimum of number of
 3 transmit or receive antennas. For open-loop transmit diversity modes, the number of streams depends on the space-
 4 time coding (STC) schemes that are used by the MIMO encoder. The MU-MIMO can support up to 2 streams with 2
 5 transmit antennas and up to 4 streams for 4 [transmit antennas](#) and [up to 8 streams for](#) 8 transmit antennas. Table 4
 6 summarized DL MIMO parameters for various MIMO modes.

7

Table 4: DL MIMO Parameters

	Number of Transmit Antennas	STC Rate per Layer	Number of Streams	Number of Subcarriers	Number of Layers
MIMO Mode 0	2	1	2	2	1
	4	1	2	2	1
	8	1	2	2	1
MIMO Mode 1 and MIMO Mode 2	2	1	1	1	1
	2	2	2	1	1
	4	1	1	1	1
	4	2	2	1	1
	4	3	3	1	1
	4	4	4	1	1
	8	1	1	1	1
	8	2	2	1	1
	8	3	3	1	1
	8	4	4	1	1
	8	5	5	1	1
	8	6	6	1	1
	8	7	7	1	1
	8	8	8	1	1
MIMO Mode 3 and MIMO Mode 4	2	1	2	1	2
	4	1	2	1	2
	4	1	3	1	3
	4	1	4	1	4
	8	1	2	1	2
	8	1	3	1	3
	8	1	4	1	4
MIMO Mode 4	4	2 and 1 ^a	3	1	2
	4	2 and 1 ^b	4	1	3
	4	2	4	1	2
	8	2 and 1 ^a	3	1	2
	8	2 and 1 ^b	4	1	3
	8	2	4	1	2
	8	1	8	1	8
	8	2 and 1 ^c	8	1	7
	8	2 and 1 ^d	8	1	6
	8	2 and 1 ^e	8	1	5
MIMO Mode 5	8	2	8	1	4
	2	1/2	1	2	1
	4	1/2	1	2	1
	7	1/2	1	2	1

8 ^a 2 streams to one AMS and 1 stream to another AMS, with 1 layer each.

9 ^b 2 streams to one AMS and 1 stream each to the other two AMSs, with 1 layer each.

10 ^c 2 streams to one AMS and 1 stream each to the other six AMSs, with 1 layer each.

11 ^d 2 streams each to two AMS and 1 stream each to the other four AMSs, with 1 layer each.

12 ^e 2 streams each to three AMS and 1 stream each to the other two AMSs, with 1 layer each.

13 For SU-MIMO, vertical encoding is utilized, whereas for MU-MIMO horizontal encoding is employed at the BS
 14 and only one stream is transmitted to each MS. The stream to antenna mapping depends on the MIMO scheme that

Wookbong 10/12/15 02:00 PM

Comment: Correct according to current standard.

1 is used. The CQI and rank feedback are transmitted to assist the BS in rank adaptation, mode switching, and rate
2 adaptation. For spatial multiplexing, the rank is defined as the number of streams to be used for each user. In FDD
3 and TDD systems, unitary codebook based precoding is used for closed-loop SU-MIMO. An MS may feedback
4 some information to the BS in closed-loop SU-MIMO such as rank, sub-band selection, CQI, precoding matrix
5 index (PMI), and long-term channel state information.

6 The MU-MIMO transmission with up to two streams one stream per user is supported. The MU-MIMO schemes
7 include 2 transmit antennas for up to 2 users, and 4 and 8 transmit antennas for up to 4 users. Both unitary and non-
8 unitary MU-MIMO schemes are supported. If the columns of the precoding matrix are orthogonal to each
9 other, it is defined as unitary MU-MIMO. Otherwise, it is defined as non-unitary MU-MIMO. Beamforming
10 is enabled with this precoding mechanism. WirelessMAN-Advanced has the capability to adapt between SU-
11 MIMO and MU-MIMO in a predefined and flexible manner. Multi-BS MIMO techniques are also supported for
12 improving sector and cell-edge throughput using multi-BS collaborative precoding, network coordinated
13 beamforming, or inter-cell interference cancellation. Both open-loop and closed-loop multi-BS MIMO techniques
14 are under consideration.

Wookbong 10/12/15 02:01 PM
Comment: Correct according to current standard.

Jeongho Park 10/12/13 02:17 PM
Comment: no need to say

Wookbong 10/12/15 02:01 PM
Comment: Only closed loop Multi-BS MIMO, and do not need to mention here.

Jeongho Park 10/12/13 02:17 PM
Comment: not very necessary

15 **B.1.3.10.2 Uplink MIMO**

16 The block diagram of uplink MIMO transmitter is illustrated in Figure 13. Note the similarities of MIMO baseband
17 processing in the downlink and uplink.

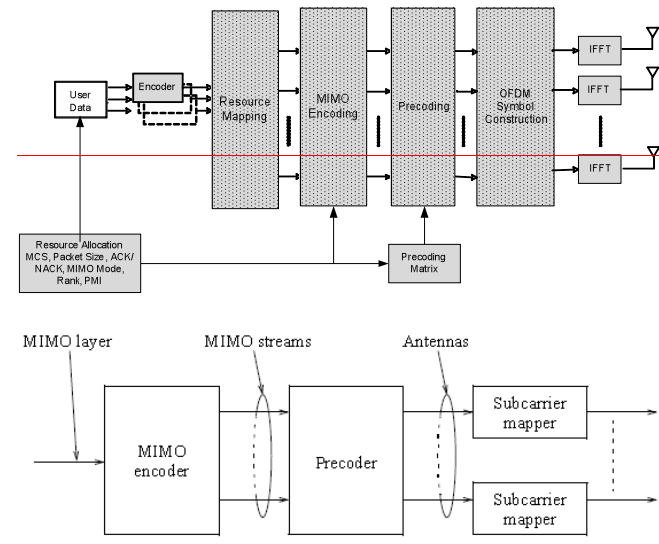

19
20
21 Figure 13: Illustration UL MIMO Structure

22 The BS will schedule users to resource blocks and determines the modulation and coding scheme (MCS) level and
23 MIMO parameters (mode, rank, etc.). The supported antenna configurations include 1, 2, or 4 transmit antennas and
24 more than two receive antennas. In the UL, the MS measurements of the channel are based on DL reference signals
25 (e.g., common pilots or a midamble). UL MIMO modes and parameters are contained in Table 5 and Table 6.

Wookbong 10/12/15 02:02 PM
Comment: Don't need for UL MIMO operation.

26 Table 5: UL MIMO Modes

Mode Index	Description	MIMO Encoding Format	MIMO Precoding
------------	-------------	----------------------	----------------

Mode 0	Open-Loop SU-MIMO (TX Diversity)	SFBC	Non-Adaptive
Mode 1	Open-Loop SU-MIMO (Spatial Multiplexing)	Vertical Encoding	Non-Adaptive
Mode 2	Closed-Loop SU-MIMO (Spatial Multiplexing)	Vertical Encoding	Adaptive
Mode 3	Open-Loop Collaborative Spatial Multiplexing (MU-MIMO)	Vertical Encoding	Non-Adaptive
Mode 4	Closed-Loop Collaborative Spatial Multiplexing (MU-MIMO)	Vertical Encoding	Adaptive

Wookbong 10/12/15 02:02 PM
Comment: For clarification.

1 Table 6: UL MIMO Parameters

	Number of Transmit Antennas	STC Rate per Layer	Number of Streams	Number of Subcarriers	Number of Layers
MIMO Mode 0	2	1	2	2	1
	4	1	2	2	1
<u>MIMO mode 1</u>	<u>1</u>	<u>1</u>	<u>1</u>	<u>1</u>	<u>1</u>
MIMO Mode 1 and MIMO Mode 2	2	1	1	1	1
	2	2	2	1	1
	4	1	1	1	1
	4	2	2	1	1
	4	3	3	1	1
MIMO Mode 3 and MIMO Mode 4	4	4	4	1	1
	<u>1</u>	<u>1</u>	<u>1</u>	<u>1</u>	<u>1</u>
	2	1	1	1	1
	<u>2</u>	<u>2</u>	<u>2</u>	<u>1</u>	<u>1</u>
	4	1	1	1	1
	4	2	2	1	1
	4	3	3	1	1
	<u>4</u>	<u>4</u>	<u>4</u>	<u>1</u>	<u>1</u>

Wookbong 10/12/15 02:03 PM
Comment: 1Tx MS

2 A number of antenna configurations and transmission rates are supported in UL open-loop SU-MIMO including 2
3 and 4 transmit antennas with rate 1 (i.e., transmit diversity mode), 2 and 4 transmit antennas with rates 2, 3, and 4
4 (i.e., spatial multiplexing). The supported UL transmit diversity modes include 2 and 4 transmit antenna schemes
5 with rate 1 such as space frequency block coding (SFBC) and rank 1 2 stream precoder. The multiplexing modes
6 supported for open-loop single-user MIMO include 2 and 4 transmit antenna rate 2 schemes with and without
7 precoding, 4 transmit antenna rate 3 schemes with precoding, 4 transmit antenna rate 4 scheme. In FDD and TDD
8 systems, unitary codebook-based precoding is supported. In this mode, the MS transmits a sounding reference signal
9 in the UL to assist the UL scheduling and precoder selection in the BS. The BS signals the resource allocation,
10 MCS, rank, preferred precoder index, and packet size to the MS. UL MU-MIMO enables multiple mobile stations to
11 be spatially multiplexed on the same radio resources. Both open-loop and closed-loop MU-MIMO are supported.
12 The mobile stations with single transmit antenna can operate in open-loop SU or MU-MIMO mode.

Wookbong 10/12/15 02:04 PM
Comment: Correct according to current standard and including 1Tx MS.

Wookbong 10/12/15 02:05 PM
Comment: Correct according to current standard.

14 **B.1.4 Overview of the WirelessMAN-Advanced MAC Layer**

15 The following sections describe selected MAC features.

16 **B.1.4.1 MAC Addressing**

17
18 WirelessMAN-Advanced standard defines global and logical addresses for a mobile station that identify the user and
19 its connections during a session. The MS is identified by the globally unique 48-bit IEEE extended unique identifier
20 assigned by the IEEE Registration Authority. The MS mobile station is further assigned the following logical
21 identifiers: 1) A station identifier during network entry (or network re-entry), that uniquely identifies the MS within
22 the cell, and 2) a flow identifier that uniquely identifies the management control connections and transport
23 connections with the MS. A temporary station identifier is used to protect the mapping between the actual station
24 identifier during network entry. A deregistration identifier is defined to uniquely identify the MS within the set of
25 paging group identifiers, paging cycle, and paging offset.

1 B.1.4.2 Network Entry

2 Network entry is the procedure through which a mobile station detects a cellular network and establishes a
3 connection with that network. The network entry has the following steps (see Figure 15):

- 4
- 5 - Synchronization with the BS by acquiring the preambles
 - 6 - Acquiring necessary system information such as BS and network service provider identifiers for initial
7 network entry and cell selection.
 - 8 - Initial ranging
 - 9 - Basic capability negotiation
 - 10 - Authentication/authorization and key exchange
 - 11 - registration and service flow setup

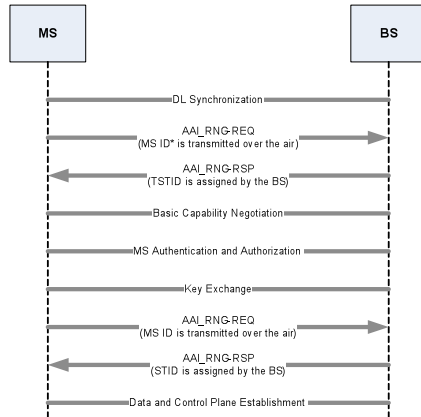

12
13 Figure 14: Network Entry Procedures

14 ~~Neighbour search is based on the same downlink signals as initial network search except some information can be
15 provided by the serving BS (i.e., neighbour advertisement messages, NBR-ADV). The BS responds to the MS initial
16 ranging code transmission by broadcasting a status indication message in the following predefined downlink
17 frame/subframe.~~

Jeongho Park 10/12/13 02:21 PM

Comment: not necessary

18 B.1.4.3 Connection Management and Quality of Service

19 A connection is defined as a mapping between the MAC layers of a BS and one (or several) MS. If there is a one-to-
20 one mapping between one BS and one MS, the connection is called a unicast connection; otherwise, it is called a
21 multicast or broadcast connection. Two types of connections are specified: control connections and transport
22 connections. Control connections are used to carry MAC control messages. Transport connections are used to carry
23 user data including upper layer signalling messages. A MAC control message is never transferred over transport
24 connection, and user data is never transferred over the control connections. One pair of bi-directional (DL/UL)
25 unicast control connections are automatically established when an MS performs initial network entry.

26 All the user data communications are in the context of transport connections. A transport connection is uni-
27 directional and established with a unique flow identifier. Each transport connection is associated with an active
28 service flow to provide various levels of QoS required by the service flow. [An MS may have multiple transport
29 connections which have different set of QoS parameters, and each transport connection may have one or more sets
30 of QoS parameters.](#) The transport connection is established when the associated active service flow is admitted or
31 activated, and released when the associated service flow becomes inactive. Transport connections can be pre-
32 provisioned or dynamically created. Pre-provisioned connections are those established by system for an MS during
33 the MS network entry. On the other hand, the BS or the MS can create new connections dynamically if required.

Jeongho Park 10/12/13 02:22 PM

Comment: From removed QoS section:
Implemented aGP service.

Jaehyuk Jang 10/12/13 02:22 PM

Comment: From removed QoS section:
Implemented aGP service.

B.1.4.4 Quality of Service

WirelessMAN-Advanced MAC assigns a unidirectional flow of packets with specific QoS requirements with a service flow. A service flow is mapped to a transport connection with a flow identifier. The QoS parameter set is negotiated between the BS and the MS during the service flow setup/change procedure. The QoS parameters can be used to schedule traffic and allocate radio resource. The uplink traffic may be regulated based on the QoS parameters.

WirelessMAN-Advanced supports adaptation of service flow QoS parameters. One or more sets of QoS parameters are defined for each service flow. The MS and BS negotiate the possible QoS parameter sets during service flow setup procedure. When QoS requirement/traffic characteristics for uplink traffic changes, the BS may adapt the service flow QoS parameters such as grant/polling interval or grant size based on predefined rules. In addition, the MS may request the BS to switch the service flow QoS parameter set with explicit signalling. The BS then allocates resource according to the new service flow parameter set. In addition to the scheduling services supported by the legacy system, WirelessMAN-Advanced provides a specific scheduling service and dedicated ranging channel to support real-time non-periodical applications such as interactive gaming.

Jeongho Park 10/12/13 02:22 PM

Comment: Need to be merged into connection management section**B.1.4.5 MAC Management Messages**

To satisfy the latency requirements for network entry, handover, and state transitions, WirelessMAN-Advanced supports fast and reliable transmission of MAC management connections. The transmission of unicast MAC management messages is made more reliable using HARQ, where retransmissions can be triggered by an unsuccessful outcome from the HARQ entity in the transmitter. If MAC management message is fragmented into multiple MAC service data units, only unsuccessful fragments are retransmitted.

Jeongho Park 10/12/13 02:23 PM

Comment: Unnecessary**B.1.4.6 MAC Header**

WirelessMAN-Advanced specifies a number of efficient MAC headers for various applications comprising of fewer fields with shorter size compared to IEEE 802.16-2009 standard generic MAC header. The advanced generic MAC header consists of Extended Header Indicator, Flow Identifier, and Payload Length fields. Other MAC header types include two-byte short-packet MAC header, which is defined to support small-payload applications such as VoIP and is characterized by small data packets and non-ARQ connection, Fragmentation extended header, and Packing extended header for transport connections, MAC Control Fragmentation extended header for management control connections, and Multiplexing extended header that is used when data from multiple connections associated with the same security association is present in the payload of the MAC PDU. The structures of some MAC headers are shown in Figure 15.

Kiseon Ryu 10/12/24 04:05 PM

Comment: Header names have been changed

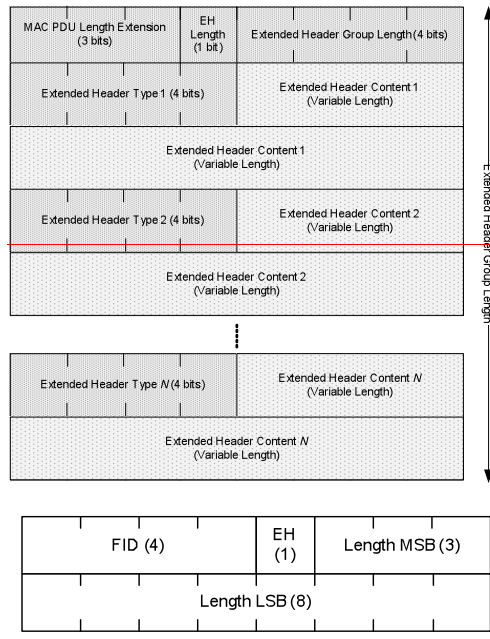

Figure 15: Structure of the WirelessMAN-Advanced Generic MAC Headers

B.1.4.7 ARQ and HARQ Functions

An ARQ block is generated from one or multiple MAC service data units (SDUs) or MAC SDU fragment(s). ARQ blocks can be variable in size and are sequentially numbered. **When both ARQ and HARQ are applied on a flow, HARQ and ARQ interactions are applied to the corresponding flow. If the HARQ entity in the transmitter determines that the HARQ process was terminated with an unsuccessful outcome, the HARQ entity in the transmitter informs the ARQ entity in the transmitter about the failure of the HARQ burst. The ARQ entity in the transmitter can then initiate retransmission and re-segmentation of the appropriate ARQ blocks.**

WirelessMAN-Advanced uses adaptive asynchronous and non-adaptive synchronous HARQ schemes in the downlink and uplink, respectively. The HARQ operation is relying on an N-process (multi-channel) stop-and-wait protocol. In adaptive asynchronous HARQ, the resource allocation and transmission format for the HARQ retransmissions may be different from the initial transmission. In case of retransmission, control signalling is required to indicate the resource allocation and transmission format along with other HARQ necessary parameters. A non-adaptive synchronous HARQ scheme is used in the uplink where the parameters and the resource allocation for the retransmission are known a priori.

Jeongho Park 10/12/13 02:24 PM
Comment: ARQ-HARQ interaction is an optional feature, and does not have to be mentioned.

B.1.4.8 Mobility Management and Handover

WirelessMAN-Advanced supports both network-controlled and MS-assisted handover (HO). **The As illustrated in Figure 16, the handover procedure may be initiated by either MS or BS; however, the final handover decision and target BS selection are may be made either by the serving BS or the network MS. The MS executes the handover as directed by the BS or cancels the procedure through HO cancellation message. The network re-entry procedure with the target BS, as shown in Figure 16, may be optimized by target BS possession of MS information obtained from serving BS via core network. The MS may also maintain communication with serving BS while performing network re-entry at target BS as directed by serving BS. Figure 16 illustrates the HO procedure.**

Jeongho Park 10/12/13 02:27 PM
Comment: To give exact description in the 16m specification.

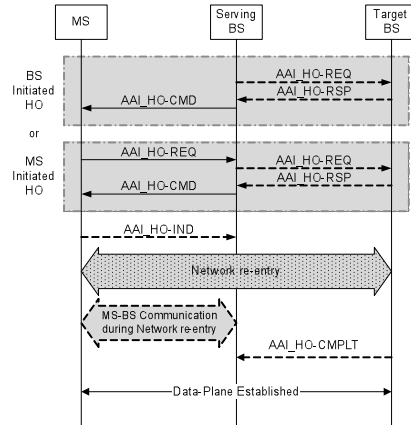

Figure 16: WirelessMAN-Advanced Handover Procedure

The handover procedure is divided into three stages 1) HO initialization, 2) HO preparation, and 3) HO execution. Upon completion of HO execution, the MS is ready to perform network re-entry with the target BS. In addition, HO cancellation procedure is defined to allow MS cancel a HO procedure.

The HO preparation is completed when the serving BS informs the MS of its handover decision via a HO control command. The signalling may include dedicated ranging resource allocation and resource pre-allocations for MS at target BS for optimized network re-entry. The control signalling includes an action time for the MS to start network re-entry at the target BS and an indication whether MS should maintain communication with serving BS during network re-entry. If the communication cannot be maintained between MS and the serving BS during network re-entry, the serving BS stops allocating resources to MS for transmission in action time. If directed by serving BS via HO control command, the MS performs network re-entry with the target BS during action time while continuously communicates with serving BS. However, the MS stops communication with serving BS after network re-entry with target BS is completed. In addition, MS cannot exchange data with target BS prior to completion of network re-entry.

Jeongho Park 10/12/13 02:27 PM

Comment: Unnecessarily detailed description, and this text is not relevant with the Figure 16.

B.1.4.8 Power Management

WirelessMAN-Advanced provides power management functions including sleep mode and idle mode to mitigate power consumption of the mobile station. Sleep mode is a state in which an MS performs pre-negotiated periods of absence from the serving BS. The sleep mode may be enacted when an MS is in the connected state. Using the sleep mode, the MS is provided with a series of alternative listening and sleep windows. The listening window is the time interval in which MS is available for transmit/receive of control signalling and data. The WirelessMAN-Advanced has the capability of dynamically adjusting the duration of sleep and listening windows within a sleep cycle based on changing traffic patterns and HARQ operations. When MS is in active mode, sleep parameters are negotiated between MS and BS. The base station instructs the MS to enter sleep mode. MAC management messages can be used for sleep mode request/response. The period of the sleep cycle is measured in units of frames or superframes and is the sum of a sleep and listening windows. During the MS listening window, BS may transmit the traffic indication message intended for one or multiple mobile stations. The listening window can be extended through explicit or implicit signalling. The maximum length of the extension is to the end of the current sleep cycle.

Idle mode allows the MS to become periodically available for downlink broadcast traffic messaging such as paging message without registration with the network. The network assigns mobile stations in the idle mode to a paging group during idle mode entry or location update. [If an MS is assigned to multiple paging groups, it may also be assigned multiple paging offsets within a paging cycle where each paging offset corresponds to a separate paging](#)

1 [group](#). The assignment of multiple paging offsets to an MS allows monitoring of the paging messages at different
2 [paging offset when the MS is located in one of its paging groups](#). The distance between two adjacent paging offsets
3 [should be long enough so that the MS paged in the first paging offset can inform the network before the next paging](#)
4 [offset in the same paging cycle occurs, thereby avoiding unnecessary paging in the next paging offset](#). The MS
5 monitors the paging message during listening interval. [The paging message contains identification of the mobile](#)
6 [stations to be notified of pending traffic or location update](#). The start of the paging listening interval is calculated
7 based on paging cycle and paging offset. ~~The paging offset and paging cycle are~~ defined in terms of number of
8 superframes. The serving BS transmits the list of paging group identifiers (PGID) at the predetermined location at
9 the beginning of the paging available interval. ~~An MS may be assigned to one or more paging groups. If an MS is~~
10 ~~assigned to multiple paging groups, it may also be assigned multiple paging offsets within a paging cycle where~~
11 ~~each paging offset corresponds to a separate paging group. The MS is not required to perform location update when~~
12 ~~it moves within its assigned paging groups. The assignment of multiple paging offsets to an MS allows monitoring~~
13 ~~paging message at different paging offset when the MS is located in one of its paging groups. When an MS is~~
14 ~~assigned to more than one paging group, one of the paging groups is called Primary Paging Group and others are~~
15 ~~known as Secondary Paging Groups. If an MS is assigned to one paging group, that paging group is considered the~~
16 ~~Primary Paging Group. When different paging offsets are assigned to an MS, the Primary Paging Offset is shorter~~
17 ~~than the Secondary Paging Offsets. The distance between two adjacent paging offsets should be long enough so that~~
18 ~~the MS paged in the first paging offset can inform the network before the next paging offset in the same paging~~
19 ~~cycle so that the network avoids unnecessary paging of the MS in the next paging offset. An Idle State MS (while in~~
20 ~~paging listening interval) wakes up at its primary paging offset and looks for primary PGIDs information. If the MS~~
21 ~~does not detect the primary PGID, it will wake up during its secondary paging offset in the same paging cycle. If the~~
22 ~~MS can find neither primary nor secondary PGIDs, it will perform a location update. The paging message contains~~
23 ~~identification of the mobile stations to be notified of pending traffic or location update. The MS determines the start~~
24 ~~of the paging listening interval based on the paging cycle and paging offset. During paging available interval, the~~
25 MS monitors the superframe header and if there is an indication of any change in system configuration information,
26 the MS will acquire the latest system information at the next instance of superframe header transmission (i.e., next
27 superframe header). To provide location privacy, the paging controller [may assign temporary Deregistration](#)
28 identifiers to uniquely identify the mobile stations in the idle mode in a particular paging group. ~~The temporary~~
29 ~~identifiers remain valid as long as the MS stays in the same paging group.~~

30 An MS in idle mode performs location update, if either of these conditions are met, paging group location update,
31 timer based location update, or power down location update. The MS performs the location update when the MS
32 detects a change in paging group. ~~The MS detects the change of paging group~~ by monitoring the PGIDs, which are
33 transmitted by the BS. The MS periodically performs location update procedure prior to the expiration of idle mode
34 timer. At every location update including paging group update, the idle mode timer is reset.

35 B.1.4.9 Security

36 Security functions provide subscribers with privacy, authentication, and confidentiality across WirelessMAN-
37 Advanced network. [The PKM protocol provides mutual and unilateral authentication and establishes confidentiality](#)
38 [between the MS and the BS by supporting transparent exchange of authentication and authorization \(EAP\)](#)
39 [messages](#).

40 [The MS and the BS may support encryption methods and algorithms for secure transmission of MAC PDUs.](#)
41 [WirelessMAN-Advanced supports selectively confidentiality or integrity protection over MAC control messages.](#)
42 ~~The MAC packet data units (PDUs) are encrypted over the connections between the MS and BS.~~ Figure 18 shows
43 the functional blocks of WirelessMAN-Advanced security architecture.

Kiseon Ryu 10/12/24 04:08 PM

Comment: DID not temporary ID is assigned for idle mode

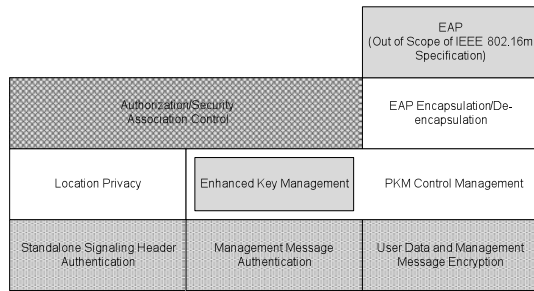

Figure 17: Functional Blocks of WirelessMAN-Advanced Security Architecture

The security architecture is divided into security management and encryption and integrity logical entities. The security management functions include overall security management and control, EAP encapsulation/de-encapsulation, privacy key management (PKM) control, security association management, and identity/location privacy. [\[To accomplish identity/location privacy, the MSID \(i.e. MS MAC address\) is not disclosed over the air even during network entry. BS assigns an STID to the MS which is securely transmitted to the MS so that the MS's identity and location can be hidden.\]](#) The encryption and integrity protection entity functions include user data encryption of user data and authentication, management control message authentication, message confidentiality protection. Authorization is a process where base station and mobile station mutually authenticate the identity of each other. Authentication is performed during initial network entry after security capabilities and policies are negotiated. The basic mobile station capability negotiation is performed prior to authentication and authorization. Re-authentication is performed before the authentication credentials expire. Data transmission may continue during re-authentication process. WirelessMAN-Advanced incorporates mechanisms such a pseudo-identity to improve user privacy. The WirelessMAN-Advanced uses the PKMv3 protocol to transparently exchange authentication and authorization (EAP) messages. The PKM protocol provides mutual and unilateral authentication and establishes confidentiality between the MS and the BS. Some WirelessMAN-Advanced keys are derived and updated by both BS and MS. The key exchange procedure is controlled by the security key state machine, which defines the allowed operations in the specific states. The key-exchange state machine is similar to that of the legacy system.

A security association (SA) is the set of information required for secure communication between BS and MS. However, the SA is not equally applied to messages within the same flow. According to the value of MAC header fields (e.g., EC, EKS, Flow ID), the SA is selectively applied to the management connections. When a service flow is established between the BS and the group of mobile stations, it is considered as multicast and it is serviced by a group SA. The mobile station and the base station may support encryption methods and algorithms for secure transmission of MAC PDUs. Advanced encryption standard (AES) is the only supported cryptographic method in WirelessMAN-Advanced. WirelessMAN-Advanced selectively protects the confidentiality of control-plane signalling. WirelessMAN-Advanced supports the selective confidentiality protection over MAC management messages. If the selective confidentiality protection is activated, the negotiated keying materials and cipher suites are used to encrypt the management messages. Integrity protection is applied to standalone MAC signalling header.

Jeongho Park 10/12/13 02:35 PM

Comment: Identity/location privacy

B.2 Detailed specification of the radio interface technology

Detailed specifications described in this Recommendation are developed around a "Global Core Specification" (GCS)⁸, which is related to externally developed materials incorporated by specific references for a specific

⁸ A "GCS" (Global Core Specification) is the set of specifications that defines a single RIT, an SRIT, or a RIT within an SRIT.

1 technology. The process and use of the GCS, references, and related notifications and certifications are found as
2 IMT-ADV/24⁹

3 The standards contained in this section are derived from the global core specifications for IMT-Advanced contained
4 at <http://ties.itu.int/u/itu-r/ede/rsg5/xxxxx/xxx/xxxxxxx/>. The following notes apply to the sections below, where
5 indicated:

6 1) The [relevant][TBD] (the *Transposing Organisations*) should make their reference material available
7 from their web site.

8 2) This information was supplied by the *Transposing Organizations* and relates to their own deliverables of
9 the transposed global core specification.

10 *[Editor's note: the above notes will be revisited when the final version of IMT.RSPEC will be finalised]*

11 *[Editor's Note: to be filled with stakeholder's input(s)]*

12 **B.2.1 WirelessMAN-Advanced Specification**

13 The WirelessMAN-Advanced specification is provided in Clause 16.1 of IEEE Std 802.16, as detailed in Section
14 B.2.2. Anything in Section B.2.2 that is not mentioned in Clause 16.1 of IEEE Std 802.16 is excluded.

15 **B.2.2 IEEE Std 802.16**

16 **Standard for local and metropolitan area networks – Air interface for broadband wireless access systems**

17 This standard specifies the air interface, including the medium access control layer (MAC) and physical layer
18 (PHY), of combined fixed and mobile point-to-multipoint broadband wireless access (BWA) systems providing
19 multiple services. The MAC is structured to support multiple PHY specifications, each suited to a particular
20 operational environment.

21 IEEE Std 802.16 is comprised of IEEE Std 802.16-2009, as amended by IEEE Std 802.16j, IEEE Std 802.16h, and
22 IEEE Std 802.16m.

23 **B.2.2.1 IEEE Std 802.16-2009**

24 **Standard for local and metropolitan area networks – Part 16: Air interface for broadband wireless access 25 systems**

26 This standard specifies the air interface, including the medium access control layer (MAC) and physical layer
27 (PHY), of combined fixed and mobile point-to-multipoint broadband wireless access (BWA) systems providing
28 multiple services. The MAC is structured to support multiple PHY specifications, each suited to a particular
29 operational environment.

30 **B.2.2.2 IEEE Std 802.16j**

31 **Standard for local and metropolitan area networks – Part 16: Air interface for broadband wireless access 32 systems – Amendment 1: Multiple relay specification**

33 This amendment updates and expands IEEE Std 802.16-2009, specifying physical layer and medium access control
34 layer enhancements to IEEE Std 802.16 for licensed bands to enable the operation of relay stations. Subscriber
35 station specifications are not changed.

36 **B.2.2.3 IEEE Std 802.16h**

37 **Standard for local and metropolitan area networks – Part 16: Air interface for broadband wireless access 38 systems – Amendment 2: Improved coexistence mechanisms for license-exempt operation**

39 This amendment updates and expands IEEE Std 802.16, specifying improved mechanisms, as policies and medium
40 access control enhancements, to enable coexistence among license-exempt systems and to facilitate the coexistence
41 of such systems with primary users.

⁹ ADV/24 is available on the ITU-R WP 5D web page under the link "IMT-Advanced documents"
(<http://www.itu.int/md/R07-IMT.ADV-C-0024/e>)

1 **B.2.2.4 IEEE Std 802.16m**

2 **Standard for local and metropolitan area networks – Part 16: Air interface for broadband wireless access**
3 **systems – Amendment 3: Advanced air interface**

4 This amendment specifies the WirelessMAN-Advanced air interface, an enhanced air interface designed to meet the
5 requirements of the IMT-Advanced standardization activity conducted by the ITU-R. The amendment is based on
6 the WirelessMAN-OFDMA specification of IEEE Std 802.16 and provides continuing support for WirelessMAN-
7 OFDMA subscriber stations.

8

9
