

Project	IEEE 802.16 Broadband Wireless Access Working Group < http://ieee802.org/16 >
Title	Define and Use of HO Ranging Code
Date Submitted	2004-06-25
Source(s)	Chulsik Yoon csyoon@etri.re.kr Yong Chang, Changhoi Koo yongchang@samsung.com , chkoo@samsung.com
Re:	Contribution on comments to IEEE P802.16e/D3
Abstract	We newly defined the handover ranging codes for fast handover for MSS and uplink resource savings for unnecessary allocation for transmission of not used large sized TLV fields such as HMAC tuple in the initial stages of network entry/handover.
Purpose	Adoption
Notice	This document has been prepared to assist IEEE 802.16. It is offered as a basis for discussion and is not binding on the contributing individual(s) or organization(s). The material in this document is subject to change in form and content after further study. The contributor(s) reserve(s) the right to add, amend or withdraw material contained herein.
Release	The contributor grants a free, irrevocable license to the IEEE to incorporate text contained in this contribution, and any modifications thereof, in the creation of an IEEE Standards publication; to copyright in the IEEE's name any IEEE Standards publication even though it may include portions of this contribution; and at the IEEE's sole discretion to permit others to reproduce in whole or in part the resulting IEEE Standards publication. The contributor also acknowledges and accepts that this contribution may be made public by IEEE 802.16.
Patent Policy and Procedures	<p>The contributor is familiar with the IEEE 802.16 Patent Policy and Procedures (Version 1.0) <http://ieee802.org/16/ipr/patents/policy.html>, including the statement "IEEE standards may include the known use of patent(s), including patent applications, if there is technical justification in the opinion of the standards-developing committee and provided the IEEE receives assurance from the patent holder that it will license applicants under reasonable terms and conditions for the purpose of implementing the standard."</p> <p>Early disclosure to the Working Group of patent information that might be relevant to the standard is essential to reduce the possibility for delays in the development process and increase the likelihood that the draft publication will be approved for publication. Please notify the Chair <mailto:r.b.marks@ieee.org> as early as possible, in written or electronic form, of any patents (granted or under application) that may cover technology that is under consideration by or has been approved by IEEE 802.16. The Chair will disclose this notification via the IEEE 802.16 web site <http://ieee802.org/16/ipr/patents/notices>.</p>

Define and use of HO ranging codes

Chulsik Yoon

ETRI

Yong Chang, Changhoi Koo

Samsung

1. Introduction

In OFDMA-PHY during the handover in the drop situation, the MSS should transmit [the RNG-REQ message](#) with the Serving BS-ID and HMAC Tuple for authentication. But, especially for OFDMA PHY, the target BS cannot know whether the MSS would trying initial ranging or handover ranging, because the MSS should use the same ranging codes.

Currently, if the MSS transmits the initial ranging code during network entry, then the BS transmits RNG-RSP with timing and power adjustment and assigns the UL resources using the CDMA Allocation IE. But, an MSS at some circumstance such as trying handover, location update in idle mode or fast call recovery, which needs more UL resources for RNG-REQ because of additional 23 bytes long HMAC Tuple, should use the same type of initial ranging code. Since the BS does not know the MSS's needs, it should allocate the UL resources for the MSS for the worst case (i.e., largest amount of resources). But the RNG-REQ message should be transmitted using the robust burst profile (in case of FUSC, 1/2-QPSK with 6 times repetition; 23 bytes of HMAC tuple and 6 bytes of serving BS-ID), the large amount of UL resources are wasted up in the case of initial ranging.

We described the procedure of handover/initial ranging using the same codes for handover/initial ranging in Figure 1. The bandwidth is wasted up and the HO delay is increased because of the additional steps for additional bandwidth requests.

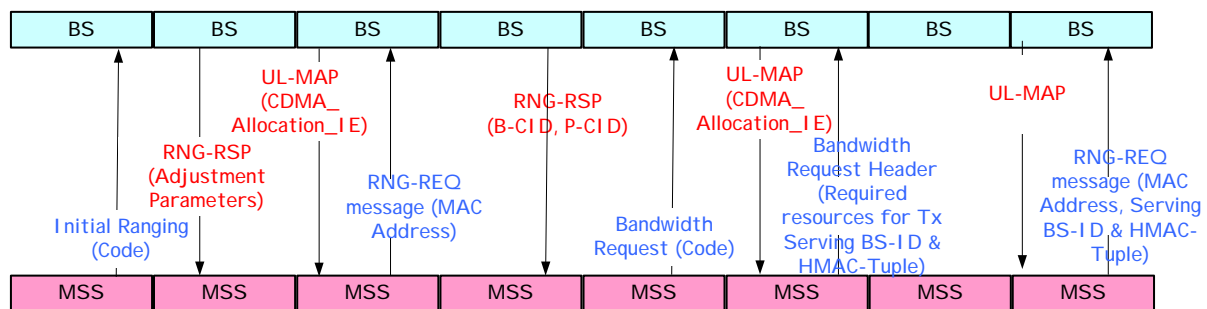

Figure 1 Handover ranging procedure using the same codes for handover/initial ranging(Not optimized bandwidth allocation, allocating the resources for only initial ranging, by BS.)

If the BS allocate the additional UL bandwidth for HO ranging [to](#) MSS (not required for the initial network entry MSS), then the precious UL bandwidth is wasted up unnecessarily (for example, approximately entire 2 symbols of 1024 FFT can be wasted up in case of FUSC in OFDMA-PHY.).

2. Overview of Proposed Solution

In this contribution, we propose to define HO ranging codes and its usage.

Define **the handover ranging code**: the ranging code which is used to indicate that MSS tries to handover, location update or fast call setup. It is on the same basis as the initial ranging codes except that it is used for handover MSS.

Type	Length	Value
173	1	<u>Number of initial ranging CDMA codes.</u> <u>Possible values are 0–255</u>

And we redefine “the start of ranging code groups” parameter to:

Type	Length	Value
155	1	<u>Indicates the starting number, S, of the group of codes used for this uplink. All the ranging codes used on this uplink will be between S and $((S+O+N+M+L) \bmod 256)$. Where, O is the number of handover-ranging codes, N is the number of initial-ranging codes, M is the number of periodic-ranging codes, L is the number of bandwidth-request codes the range of values is.</u>

We described the proposed procedures for the initial ranging case in Figure 2 and handover ranging case using the handover ranging codes in Figure 3. As we can see in Figure 3, the handover procedure can be performed in a more swift fashion than that of Figure 1 (current mechanism).

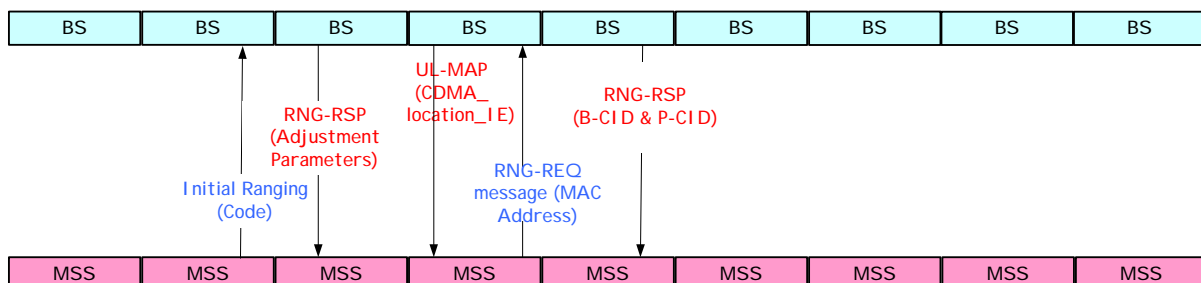

Figure 2 Initial Ranging Procedure for OFDMA-PHY

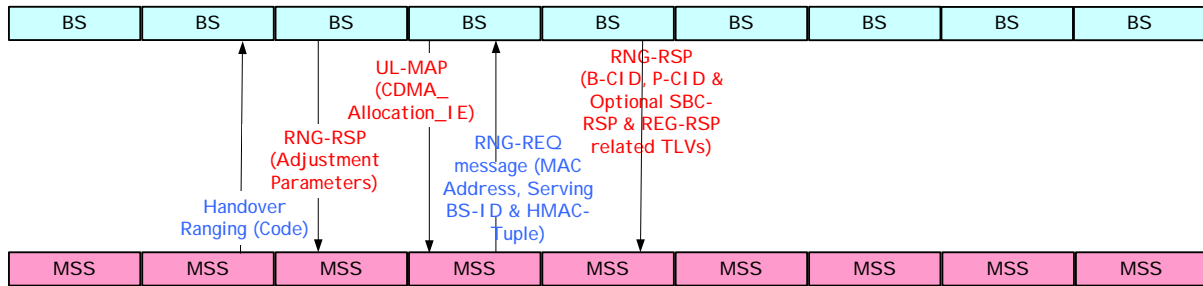

Figure 3 Handover Ranging Procedure for OFDMA-PHY

3. Proposed Text Changes

[Modify the corresponding sections as follows:]

11.3.1 UCD Encodings

Define and add the “Handover Initial Ranging Code” parameter in Table 351 and change “the start of ranging code groups” parameter to that.

Table 351—UCD PHY-specific channel encodings — WirelessMAN-OFDMA

Name	Type	Length	Values
Handover Ranging Codes	173	1	Number of handover ranging CDMA codes. Possible values are 0–255.
the start of ranging code groups	155	1	Indicates the starting number, S, of the group of codes used for this uplink. All the ranging codes used on this uplink will be between S and ((S+O+N+M+L) mod 256). Where, O is the number of handover-ranging codes , N is the number of initial-ranging codes, M is the number of periodic-ranging codes, L is the number of bandwidth-request codes the range of values is.

[Change the following sections as follows:]

6.3.20.3 Drops during HO

A drop is defined as the situation where an MSS has stopped communication with its Serving BS (either in the downlink, or in the uplink) before the normal HO sequence outlined in Cell Selection and Termination with the Serving BS has been completed.

An MSS can detect a drop by its failure to demodulate the downlink, or by exceeding the RNG-REQ retries limit allowed for the periodic ranging mechanism. A BS can detect a drop by exceeding the Number of retries on inviting Ranging Requests limit allowed for the

periodic ranging mechanism. When the MSS has detected a drop and a new BS, it shall attempt the drop HO procedure with the (target) BS using the HO ranging codes before the expiration of the Serving BS Aging Timer. Otherwise, the MSS shall attempt the network re-entry with its preferred target BS as outlined in Section ~~6.4.18.46.3.9.5~~ Initial ranging and automatic adjustment. When the BS has detected a drop, it shall react as if a MOB-HO-IND MAC Management message has been received with HO_IND_type indicating Serving BS release.

[Change the following Sections as follows:]

8.4.7 OFDMA ranging

When used with the WirelessMAN-OFDMA PHY, the MAC layer shall define a single ranging channel. This ranging channel is composed of one or more groups of six adjacent subchannels, where the groups are defined starting from the first subchannel. Optionally, ranging channel can be composed of eight adjacent subchannels using the symbol structure defined in 8.4.6.2.5. The indices of the subchannels that compose the ranging channel are specified in the UL-MAP message. Users are allowed to collide on this ranging channel. To effect a ranging transmission, each user randomly chooses one ranging code from a bank of specified binary codes. These codes are then BPSK modulated onto the subcarriers in the ranging channel, one bit per subcarrier (subcarriers used for ranging shall be modulated with the waveform specified in 8.4.7.1/8.4.7.2 and are not restricted to any time grid specified for the the data subchannels).

8.4.7.1 Initial-ranging/Handover-ranging transmissions

The initial-~~ranging~~/handover-ranging transmission shall be used by any SS that wants to synchronize to the system channel for the first time. An initial-ranging/handover-ranging transmission shall be performed during two consecutive symbols. The same ranging code is transmitted on the ranging channel during each symbol, with no phase discontinuity between the two symbols. A time-domain illustration of the initial-ranging/handover-ranging transmission is shown in Figure 239.

*[The **title** of the Figure 239 and Figure 240 changed as follows:]*

Figure 239—Initial-ranging/handover-ranging transmission for OFDMA

The BS can allocate two consecutive initial-~~ranging~~/handover-ranging slots, onto those the SS shall transmit the two consecutive initial-ranging/handover-ranging codes (starting code shall always be a multiple of 2), as illustrated in Figure 240:

Figure 240—Initial-ranging/handover-ranging transmission for OFDMA, using two consecutive initial ranging codes

[Change the paragraph in the corresponding section as follows:]

8.4.7.3. Ranging Codes

The number of available codes is 256, numbered 0..255. Each BS uses a sub-group of these codes, where the sub-group is defined by a number S , $0 \leq S \leq 255$. The group of codes will be between S and $((S+O+N+M+L) \bmod 256)$.

- The first N codes produced are for initial-ranging. For example, for the default case of two sub-channels in the ranging channel, clock the PRBS $120 \times (S \bmod 256)$ times to $120 \times ((S + N) \bmod 256) - 1$ times.
- The next M codes produced are for periodic-ranging. For example, for the default case of two subchannels in the ranging channel, clock the PRBS $120 \times ((N + S) \bmod 256)$ times to $120 \times ((N + M + S) \bmod 256) - 1$ times.
- The next L codes produced are for bandwidth-requests. For example, for the default case of two subchannels in the ranging channel, clock the PRBS $120 \times ((N + M + S) \bmod 256)$ times to $120 \times ((N + M + L + S) \bmod 256) - 1$ times.
- The next O codes produced are for handover-ranging. For example, for the default case of two subchannels in the ranging channel, clock the PRBS $120 \times ((N + M + L + S) \bmod 256)$ times to $120 \times ((N + M + L + O + S) \bmod 256) - 1$ times.