

Project	IEEE 802.16 Broadband Wireless Access Working Group < http://ieee802.org/16 >	
Title	Sleep Mode Generic Mechanism	
Date Submitted	12-Nov-04	
Source(s)	<p>Vladimir Yanover et al. Alvarion Ltd. 21 A Habarzel St. Ramat - Hahayal Tel - Aviv 69710 P.O. Box 13139, Tel-Aviv 61131, Israel Itzik Kitroser, Runcom Ltd. Yigal Eliaspur, Ben-Porath Sharon, Rosner Gedon, Efraim Sagi Penny, Intel Corp. Jung Je Son, Yeong-Moon Son, Changhoi Koo and Yong Chang, Samsung Electronics Mo-Han Fong (Nortel Networks)</p>	<p>Voice: +972-36457834 Fax: +972-36456222 mailto: vladimir.yanover@alvarion.com Voice:+972-547884877 mailto: yigal.eliaspur@intel.com</p>
Re:	The document supports a comment at Sponsor Ballot on 802.16e/D5 document	
Abstract	The documents suggests text changes to incorporate different cases of Sleep Mode operations into a single scheme	
Purpose	The document is for consideration during Sponsor Ballot comments resolution	
Notice	This document has been prepared to assist IEEE 802.16. It is offered as a basis for discussion and is not binding on the contributing individual(s) or organization(s). The material in this document is subject to change in form and content after further study. The contributor(s) reserve(s) the right to add, amend or withdraw material contained herein.	
Release	The contributor grants a free, irrevocable license to the IEEE to incorporate material contained in this contribution, and any modifications thereof, in the creation of an IEEE Standards publication; to copyright in the IEEE's name any IEEE Standards publication even though it may include portions of this contribution; and at the IEEE's sole discretion to permit others to reproduce in whole or in part the resulting IEEE Standards publication. The contributor also acknowledges and accepts that this contribution may be made public by IEEE 802.16.	
Patent Policy and Procedures	<p>The contributor is familiar with the IEEE 802.16 Patent Policy and Procedures <http://ieee802.org/16/ipr/patents/policy.html>, including the statement "IEEE standards may include the known use of patent(s), including patent applications, provided the IEEE receives assurance from the patent holder or applicant with respect to patents essential for compliance with both mandatory and optional portions of the standard." Early disclosure to the Working Group of patent information that might be relevant to the standard is essential to reduce the possibility for delays in the development process and increase the likelihood that the draft publication will be approved for publication. Please notify the Chair <mailto:chair@wirelessman.org> as early as possible, in written or electronic form, if patented technology (or technology under patent application) might be incorporated into a draft standard being developed within the IEEE 802.16 Working Group. The Chair will disclose this notification via the IEEE 802.16 web site <http://ieee802.org/16/ipr/patents/notices>.</p>	

Sleep Mode Generic Mechanism

*Vladimir Yanover (Alvarion Ltd.), Yigal Eliaspur, Ben-Porath Sharon,
Rosner Gedon, Efraim Sagi Penny (Intel Corp.), Itzik Kitroser (Runcom),
Jung Je Son, Yeong-Moon Son, Changhoi Koo, Yong Chang (Samsung Electronics)
Mo-Han Fong (Nortel Networks), Beomjoon Kim (LG Electronics)*

1. Problem Description

In 802.16e standard the Sleep Mode is defined for the purpose of power efficient operations. The Sleep Mode procedure includes listening window of constant size and doubling sleep window. Such behavior perfectly fits the behavior of demand created by “random” (“bursty”) IP traffic, like WEB browsing. Such traffic typically is carried in NRT-VR or BE connections. Applications of this type typically produce more traffic once a single packet appears. So it is natural for to terminate sleep mode each time demand showed up at the connection

But demand may have different pattern and pattern may be different at different connections. In the case of UGS, the demand for transmission of N bytes appears each M milliseconds, so it would be natural for the MSS to have listening window of constant size around time instances where demand is expected with sleep windows in-between. As opposite to WEB browsing, data transmission within listening window should be allowed without interruption of sleep state. Then the cost of Sleep Mode interruption would be that the BS and the MSS exchange MOB_SLP-REQ/RSP messages after each transferred packet.

Applications like SMS represent yet one more type of desired behavior: only small demand appears irregularly, so it is more natural to transfer this small amount of data without terminating the Sleep Mode.

Specific problem with multicast / broadcast services is that MSS may have both multicast connection(s) and unicast connections with different demand patterns, so synchronization of sleep/listening cycles between different MSSs is nearly impossible. Under current Sleep Mode scheme, the only reasonable solution is to interrupt Sleep Mode for all involved MSSs and to arrange data transfer. The cost of Sleep Mode interruption is time for getting out of Sleep Mode and air interface overhead. Additionally, as defined in current version, initial value of sleep-window is 6 bits only, therefore maximum 63 frames, which is far from reasonable maximum value that might be achieved previously. So restarting sleep mode is inefficient also from the point of view of MSS power consumption.

Another problem is combining Sleep Mode operations with maintenance and management procedures like Periodic Ranging, SNMP operations etc. Suppose that MSS is in Sleep Mode as there is no demand at existing traffic connections and there is a need for SNMP operations or other management procedure, then BS has to keep the MSS available for SNMP transaction. Existing traffic connections still have no demand, so there is no reason to interrupt their Sleep state. But existing procedure prescribes to terminate Sleep Mode (by “Traffic Indication” message though there is no traffic) perform SNMP procedure and restart Sleep.

Periodic Ranging procedure as described in the standard, appears as an exceptional case handled by special arrangement. Seems profitable to include it into general scheme as a particular case.

2. Idea of Solution

Definition of Sleep Mode for MSS should be extended. If the MSS has several services of different types (or for UGS, RT-VR with different parameters), then for each service type a separated Sleep Mode context should be created. Sleep Mode entrance/termination conditions for each state machine include presence of demand at corresponding connections, so they are independent of each other. Each of these independent Sleep Mode state machines provides certain sequence of sleep/listening windows. The MSS may power down in intervals at which ALL state machines show “sleep” state.

For example, let’s assume that a MSS has two Power Saving Classes: Class A contains one or several connections of BE and NRT-VR type, Class B contains a single connection of UGS type (see Figure NNN below). Then for Class A the BS allocates sequence of listening window of constant size and doubling sleep window. For Class B the BS allocates sequence of listening window of constant size and sleep window of constant size. The MSS is considered unavailable (and may power down) within intersections of sleep windows of A and B. Now, let’s consider one of listening windows for Class B. Supposedly there is a transmission demand of UGS connection at the window, so the BS allocates certain capacity to transfer the data within listening window; after transfer the connection returns to “sleep” state. If during all this activity NRT-VR connection has no demand, it stays in “sleep” state and there is no need in re-starting Sleep Mode with already achieved maximum sleep window size.

The following picture illustrates suggested Sleep implementation for multicast connection. The corresponding Power Saving Class is associated with the corresponding multicast connection. When activated (by MOB_SLP-RSP from BS), the class of this type provides a single sleep window. After expiration of sleep window, the MSS is awake and if multicast data is already available, it may be transferred, otherwise Power Saving Class is re-activated and the MSS enters sleep window.

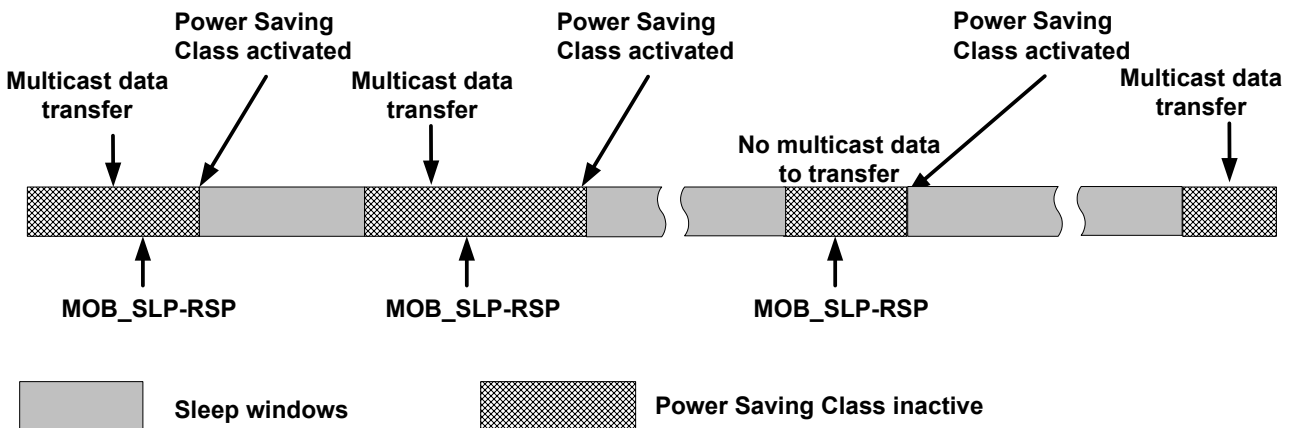

Power Saving Class for multicast connection

Next picture describes suggested Sleep implementation for Periodic Ranging procedure. The corresponding Power Saving Class is associated with Basic connection of the MSS. At initial point MSS and BS perform Periodic Ranging transaction using RNG-REQ/RSP messages that contain TLVs to configure and activate Power Saving Class of same type as for multicast connections. After expiration of sleep window of this class BS and MSS exchange of RNG-REQ/RSP messages, which may re-activate Power Saving Class etc.

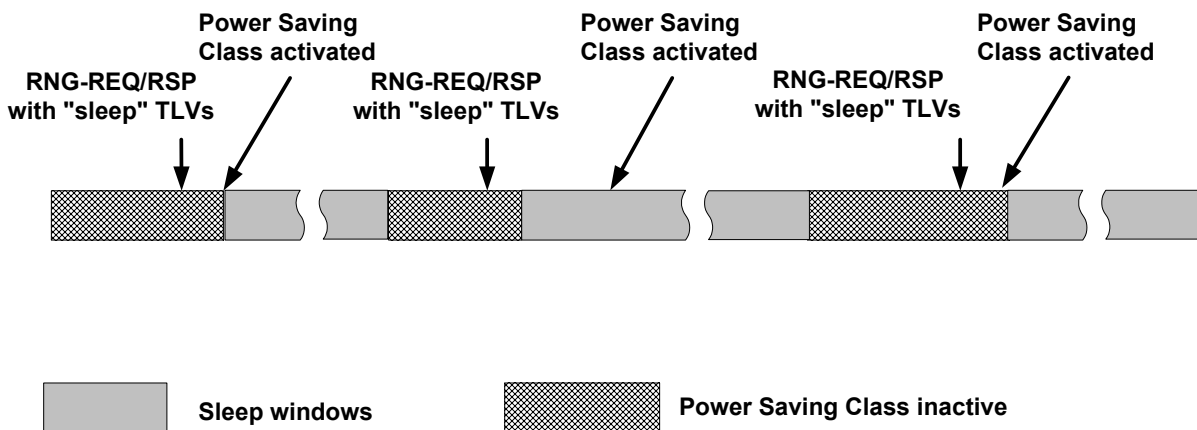

Power Saving Class Usage for Periodic Ranging

Suggested changes in 802.16e have the following advantages

- Set of parameters and behavior of MSS with a single Power Saving Class of certain type (Type 1 specified below) is the same as in currently defined Sleep Mode procedure
- Universal set of parameters and universal structure of MOB-SLP-REQ/RSP messages defined
- New Sleep Mode option added: Power Saving Classes of types 2 and 3
- Type 3 allows for supporting broadcast / multicast connections and management procedures (Periodic Ranging, DSx, broadcast management messages like NBR-ADV etc.): Power Saving Classes of type 3 BS may decide to use this procedure also to keep certain MSSs awake up to arrival of nearest DCD or UCD messages.

3. Specific Changes in 802.16e/D5

[Replace sections 6.3.19.1- 6.3.19.2 starting from p. 59, line 14, with the following text]

6.3.19.1 Introduction

Sleep Mode is a state in which an MSS conducts pre-negotiated periods of absence from the Serving BS air interface. These periods are characterized by the unavailability of the MSS, as observed from the Serving BS, to DL or UL traffic. Sleep Mode is intended to minimize MSS power usage and decrease usage of Serving BS air interface resources. Implementation of sleep-mode is optional for the MSS and mandatory for the BS.

For each involved MSS the BS keeps one or several contexts, each one related to certain Power Saving Class. Power Saving Class is a group of connections, which have common demand properties. For example, all BE and NRT-VR connections may be marked as belonging to a single class while two UGS connections may

belong to two different classes in case they have different intervals between consequent allocations. Power Saving class may be repeatedly activated and deactivated. Activation of certain Power Saving Class means starting sleep/listening windows sequence associated with this class. Algorithm of choosing Power Saving Class type for certain connections is outside of the scope of the standard.

MSS shall be capable of supporting at least 4 Power Saving Classes simultaneously.

There are three types of Power Saving Classes, which differ by their parameter sets, procedures of activation/deactivation and policies of MSS availability for data transmission.

Unavailability interval is a time interval that does not overlap with any listening window of any active Power Saving Class

Availability interval is a time interval that does not overlap with any Unavailability interval

During Unavailability interval the BS shall not transmit to the MSS, so the MSS may power down one or more physical operation components or perform another activities that do not require communication with the BS: scanning neighbor BSs, associating with neighbor BSs etc. If there is a connection at the MSS, which is not associated with any active Power Saving Class, the MSS shall be considered available on permanent basis.

During Availability interval the MSS is expected to receive all DL transmissions same way as in the state of normal operations (no sleep). In addition, the MSS shall examine the DCD and UCD change counts and the frame number of the DL-MAP PHY Synchronization Field to verify synchronization with the BS. Upon detecting a changed DCD and/or UCD count in the DL MAP, the MSS shall continue reception until receiving the corresponding updated message.

During Unavailability intervals for MSS the BS may buffer (or it may drop) MAC SDUs addressed to unicast connections bound to an MSS. The BS may choose to delay transmission of SDUs addressed to multicast connections until to following Availability Interval, common for all MSSs participating in the multicast connection.

An MSS performing handover may include *Power_Saving_Class_Parameters* in RNG-REQ message to indicate its preference to enter Sleep Mode after the handover. In this case, the BS shall transmit unsolicited MOB_SLP-RSP message to the MSS after handover.

In MOB-TRF-IND message with negative indication for the MSS, the BS may include an updated SLPID for a MSS by appending SLPID_Update TLV in the MOB-TRF-IND message. When the received MOB-TRF-IND message includes a SLPID_Update TLV, the MSS shall decode the TLV and, if addressed, update its SLPID to the new one. The MSS shall identify if the SLPID_Update TLV addresses it by searching through the SLPID_Update TLV and determining if the MSS's current SLPID matches the Old_SLPID in the SLPID_Update TLV. If they match, then the MSS shall set its SLPID to the New_SLPID provided in the SLPID_Update TLV. For an example of sleep mode operation, see Annex E.

MSS in Sleep Mode may participate in periodic ranging. The procedure includes Serving BS allocation of UL transmission opportunity for periodic ranging in which the MSS shall transmit RNG-REQ message. After transmittal of the RNG-REQ, the MSS shall wait for the RNG-RSP message. Participation in the periodic ranging procedure does not change state of Power Saving Classes not associated with Ranging procedure.

The Serving BS may verify MSS exit from Sleep Mode by making a UL allocation for MSS at any time subsequent to supposed waking event (for example, positive indication in MOB_TRF-IND message) by transmitting at least BR message (if there is no data to transmit, BR field of the BR PDU shall be set to 0).

Figure NNN describes example of behavior of MSS with two Power Saving Classes: Class A contains several connections of BE and NRT-VR type, Class B contains a single connection of UGS type. Then for Class A the BS allocates sequence of listening window of constant size and doubling sleep window. For Class B the BS allocates sequence of listening window of constant size and sleep window of constant size. The MSS is considered unavailable (and may power down) within windows of unavailability, which are intersections of sleep windows of A and B.

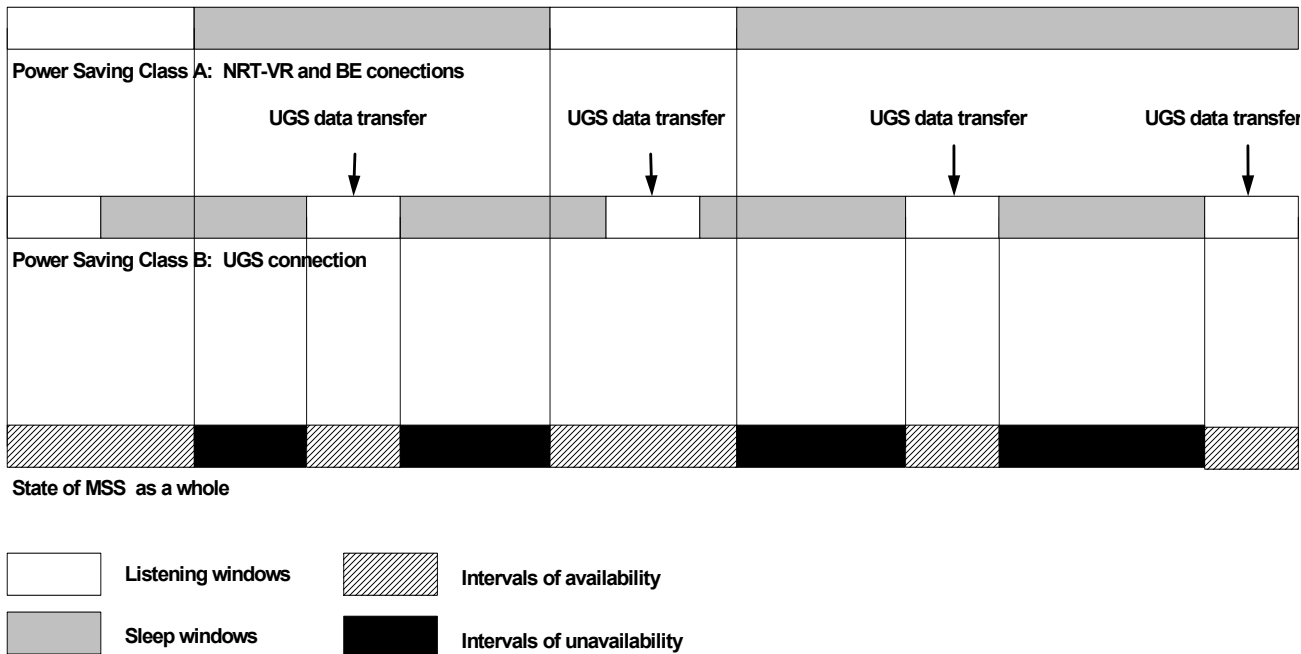

Figure NNN. Example of Sleep Mode Operations with two Power Saving Classes

6.3.19.2 Power Saving Classes of type 1

Power Saving Class of this type is recommended for connections of BE, NRT-VR type.

For definition and/or activation of one or several Power Saving Classes of Type 1 the MSS shall send MOB_SLP-REQ; the BS shall respond with an MOB-SLP_RSP message. The BS may send an unsolicited MOB-SLP-RSP to the MSS to activate one or several Power Saving Classes.

Alternatively Power Saving Class may be defined/activated /deactivated by TLVs transmitted in RNG-RSP message or by Sleep Signaling Header MOB_SLP-DLC or MOB_SLP_ULC.

The following are relevant parameters

- Initial-sleep window
- Final-sleep window base
- Listening window

- Final-sleep window exponent
- Start frame number for first sleep window
- Traffic triggered waking flag

Power Saving Class becomes active at the frame specified as Start frame number for first sleep window. Each next sleep window is twice of size comparatively to previous one, but not greater than specified final value

Sleep window = min (2(Previous sleep window), Final-sleep window base * 2 ^ (Final-sleep window exponent))*

Sleep windows are interleaved with listening windows of fixed duration. The BS terminates active state of Power Saving Class by sending MOB-TRF_IND message. A traffic indication (MOB_TRF-IND) message shall be sent by the BS on broadcast CID during listening window to alert MSS of appearance of DL traffic demand at the corresponding connections.

When an MSS receives an UL allocation after receiving a positive MOB_TRF-IND message indication, the MSS shall transmit at least BR message (if there is no data to transmit, BR field of the BR PDU shall be set to 0).

During active state of Power Saving Class of Type 1 the MSS is not expected to send or receive any MAC SDUs or their fragments or to send bandwidth requests at connections that belong to the Power Saving Class.

Power Saving Class is deactivated either by MOB_SLP-REQ or MOB_SLP-RSP messages or (if Traffic triggered waking flag = 1) after one of following events:

- BS transmits (during availability window) a MAC SDU or fragment thereof over connection belonging to the Power Saving Class
- MSS transmits a bandwidth request with respect to connection belonging to the Power Saving Class
- MSS receives MOB_TRF-IND message indicating presence of buffered traffic addressed to the MSS

Assuming TRF-IND_Required flag was set in MOB_SLP-REQ, Power Saving Class shall be deactivated if MSS failed to receive MOB_TRF-IND message during availability window.

During listening windows the MSS is expected to receive all DL transmissions same way as in the state of normal operations (no sleep).

Appearance of Next Periodic Ranging TLV in MOB_SLP-RSP activates Power Saving Class of Type 3 associated with Periodic Ranging procedure. In this case, BS may continue to activate the Power Saving Class Type 3 using Next Periodic Ranging TLV encoding in RNG-RSP message with ranging status set to success.

6.3.19.3 Power Saving Classes of type 2

Power Saving Class of this type is recommended for connections of UGS, RT-VR type. The following are relevant parameters

- Initial-sleep window
- Listening window
- Start frame number for first sleep window

Power Saving Class becomes active at the frame specified as “Start frame number for first sleep window”. All sleep windows are of the same size as initial window. Sleep windows are interleaved with listening windows of fixed duration. Power Saving Classes of this type are defined/activated/deactivated by MOB_SLP-REQ/ MOB_SLP-RSP transaction. The BS may send unsolicited MOB_SLP-RSP to initiate activation of Power Saving Class. Once started, the active state continues until explicit termination by MOB_SLP-REQ/MOB_SLP-RSP messages. BS may send unsolicited MOB_SLP-RSP message to deactivate Power Saving Class. Alternatively Power Saving Class of type 2 may be defined and/or activated /deactivated by TLVs transmitted in RNG-REQ and RNG-RSP message.

As opposite to Power Saving Class Type 1, during listening windows of Power Saving Class Type 2 the MSS may send or receive any MAC SDUs or their fragments at connections comprising the Power Saving Class as well as acknowledgements to them. The MSS shall not receive or transmit MAC SDUs during sleep windows.

6.3.19.4. Power Saving Classes of type 3

Power Saving Class of this type is recommended for multicast connections as well as for management operations, for example, Periodic Ranging, DSx operations, MOB_NBR-ADV etc. Power Saving Classes of this type are defined/activated by MOB_SLP-REQ/MOB_SLP-RSP transaction. The BS may send unsolicited MOB_SLP-RSP to initiate activation of Power Saving Class. Deactivation of Power Saving Class occurs automatically after expiration of sleep window.

Alternatively Power Saving Class of type 3 may be defined/activated by TLV encodings in RNG-RSP message. For periodic ranging Next Periodic Ranging TLV encoding may be used. It activates special Power Saving Classes of type 3 associated with periodic ranging procedure. In this case the sleep window of the class starts in the next frame after RNG-RSP transmitted and ends in the previous frame, which Next Periodic Ranging TLV indicates.

If Next Periodic Ranging TLV encoding is included in MOB_SLP-RSP, this activates Power Saving Class of type 3 for periodic ranging and BS can continue to activate the Power Saving Class using Next Periodic Ranging TLV encoding in RNG-RSP message with ranging status set to success.

The following are relevant parameters:

- Final-sleep window base
- Final-sleep window exponent
- Start frame number for sleep window

Power Saving Class becomes active at the frame specified as “Start frame number for first sleep window”. Duration of sleep window is specified as base / exponent. After the expiration of the sleep window Power Saving Class automatically becomes inactive.

For multicast service Base Station may guess when the next portion of data will appear. Then the BS allocates sleep window for all time when it does not expect the multicast traffic to arrive. After expiration of the sleep window multicast data, if already available, may be transmitted to relevant MSSs. After that the BS may decide to re-activate Power Saving Class.

As an example, Power Saving Class of type 3 may include Basic connection to serve needs of Periodic Ranging. In this case duration (base / exponent) of sleep window shall be equal to time interval needed before next Periodic ranging transaction. Then the MSS, after the specified time interval, shall be available to DL

transmission and BS may either allocate an UL transmission opportunity for RNG-REQ or send unsolicited RNG-RSP. Re-activation of the Power Saving Class may be achieved using, for example, TLVs included into RNG-REQ/RSP

Alternatively Power Saving Class of type 3 may be activated /deactivated by TLVs transmitted in RNG-RSP or DBPC-RSP messages.

[Change section 6.3.19.3, page 111 line 49]

6.3.19.5. ~~6.3.19.3~~ Periodic Ranging in Sleep Mode

For each MSS in Sleep Mode, during its listening-window, BS may allocate an UL transmission opportunity for periodic ranging. Alternatively, BS may return the MSS to Normal Operation ~~using MOB_TRF_IND~~ by **deactivation of at least one Power Saving Class** to keep it in active state until assignment of a UL transmission opportunity for periodic ranging, or let the MSS know when the periodic ranging opportunity shall occur with Next Periodic Ranging TLV in last successful RNG-RSP.

During periodic ranging or negotiation of Sleep Mode, after RNG-REQ (or MOB_SLP-REQ respectively) reception, BS may send RNG-RSP (or MOB_SLP_RSP, respectively) including Next Periodic Ranging TLV so that MSS shall know when to perform periodic ranging **as described in more details in 6.3.19.4**. In the frame specified by Next Periodic Ranging TLV, the MSS shall decode all consequent UL-MAP messages waiting for a UL unicast transmission opportunity for periodic ranging. When such an opportunity occurs, the MSS shall transmit a RNG-REQ message to the BS and then perform the regular procedure for periodic ranging (i.e. wait for RNG-RSP, etc...). A successful periodic ranging procedure does not **deactivate another Power Save Classes interrupt Sleep Mode**. In the case where periodic ranging procedure fails, the MSS shall perform Initial Ranging procedure or handover to another BS.

When the periodic ranging operation between MSS and BS successfully processes, the BS may inform the MSS of the frame number in which the next periodic ranging operation is expected to start. For that, BS shall append a Next Periodic Ranging TLV encoding to the RNG-RSP message. BS also may inform MSS of the existence of DL Traffic addressed to MSS. For that, BS shall include the Next Periodic Ranging TLV with a value set to zero. **This deactivates all Power Saving Classes at the MSS**. If an MSS receives the RNG-RSP message with this indication from the BS, then the MSS shall immediately ~~exit Sleep Mode~~ and resume Normal Operation with the BS.

The BS may include a SLPID_Update TLV item in a RNG-RSP message for an MSS in Sleep Mode. If the Serving BS receives a RNG-REQ message from an MSS in Sleep Mode and there is any need to update SLPID assigned to the MSS, the BS shall append a SLPID_Update TLV to the RNG-RSP message only for a RNG-RSP message with ranging status flag set to 'success'. When the received RNG-RSP message with ranging status flag set to 'success' includes a SLPID_Update TLV, the MSS shall decode the TLV and update its SLPID to the new one. The MSS shall identify if the SLPID_Update TLV addresses it by searching through the SLPID_Update TLV and determining if the MSS's current SLPID matches the Old_SLPID in the SLPID_Update TLV. If they match, then the MSS shall set its SLPID to the New_SLPID provided in the SLPID_Update TLV. For an example of sleep mode operation, see Annex E.

[Replace section 6.3.2.3.44, page 55, line53]

6.3.2.3.44 Sleep Request message (MOB_SLP-REQ)

MSS supporting sleep-mode uses the MOB_SLP-REQ message to request definition and/or activation of certain Power Save Classes of types 1 and 2. The MOB_SLP-REQ message is sent from the MSS to the BS on the MSS's Basic CID. If Definition bit is set, the message contains suggested by the MSS definition of new Power Saving Class.

Table 106a—Sleep-Request (MOB-SLP-REQ) message format

Syntax	Size	Notes
MOB_SLP-REQ_Message_Format() {		
Management message type = 51	8 bits	
for (i = 0; i < Number_of_Classes; i++) {		
Definition	1 bits	
Operation	1 bits	
Power Saving Class ID	6 bits	
if (Operation = 1) {		
Start frame number	6 bits	
Reserved	2 bits	
}		
if (Definition = 1) {		
Power Saving Class Type	2 bits	
Direction	2 bits	
Traffic triggered wakening flag	1 bits	
reserved	3 bits	
initial-sleep window	8 bits	
listening window	8 bits	
final-sleep window base	10 bits	
final-sleep window exponent	3 bits	
Number of CIDs	3 bits	
for (i = 0; i < Number_of_CIDs; i++) {		
CID	16 bits	
}		
}		
}		

Parameters shall be as follows:

Definition

1 = Definition of Power Saving Class present

0 = Definition of Power Saving Class absent; in this case the message shall request activation or deactivation of Power Saving Class identified by Power_Saving_Class_ID

Operation

1 = Activation of Power Saving Class

0 = Deactivation of Power Saving Class (for types 1 and 2 only)

Power_Saving_Class_ID

Assigned Power Saving Class identifier. The ID shall be unique within the group of Power Saving Classes associated with the MSS. This ID may be used in further MOB_SLP-REQ/RSP messages for activation / deactivation of Power Saving Class

Start_frame_number

Start frame number for first sleep window

Direction

Defined the directions of the class's CIDs.

00 = Un-specified. Each CID has its own direction assign in its connection creation. Can be DL, UL or both (in the case of management connections).

10 = Uplink direction only

01 = Downlink direction only

11 = Reserved

Traffic_triggered_wakening_flag (for Type 1 only)

1 = Power Saving Class shall be deactivated if traffic appears at the connection as described in 6.3.19.2.

0 = Power Saving Class shall not be deactivated if traffic appears at the connection as described in

6.3.19.2.Listening window

Assigned Duration of MSS listening window (measured in frames). For Power Saving Class type 3 it is not relevant and shall be encoded as 0

Initial-sleep window

Assigned initial duration for the sleep window (measured in frames). For Power Saving Class type 3 it is not relevant and shall be encoded as 0

Final-sleep window base

Assigned final value for the sleep interval (measured in frames).). For Power Saving Class type 2 it is not relevant and must be encoded as 0. For Power Saving Class type 3 it is the base for duration of single sleep window requested by the message

Final-sleep window exponent

Assigned factor by which the final-sleep window base is multiplied in order to calculate the final-sleep window. The following formula is used:

final-sleep window = final-sleep window base $\times 2^{(\text{final-sleep window exponent})}$

For Power Saving Class type 2 it is the exponent for the duration of single sleep window requested by the message

Number_of_CIDs

If Number_of_CIDs = 0, it means that all unicast CIDs associated with the MSS are requested for addition to the class.

CID

CIDs of unicast connections comprising the Power Saving Class. CID = 0 denotes set of all management connections associated with the MSS.

[Replace section 6.3.2.3.45, page 57, line 1]**6.3.2.3.45 Sleep Response message (MOB_SLP-RSP)**

The MOB-SLP_RSP message shall be sent from BS to a MSS on Broadcast CID or on the MSS's Basic CID in response to an MOB-SLP_REQ message, or may be sent unsolicited. If Definition bit is set, the message contains definition of new Power Saving Class together with assigned Power_Saving_Class_ID which shall be unique per MSS if includes only unicast traffic connections and unique per cell if includes only multicast connections. Mixture of multicast and unicast connections in a single class is not allowed.

After reception of the message, the MSS shall assemble connections in Power Saving Classes and optionally activate them as requested in the message. If for certain class activation is deferred (Activation = '0'), the BS may signal activation at later time in another unsolicited MOB-SLP_RSP message.

Table 106b—Sleep-Response (MOB-SLP-RSP) message format

Syntax	Size	Notes
MOB_SLP-RSP_Message_Format() {		
Management message type = 51	8 bits	
For (i = 0; i < Number_of_Classes; i++) {		
Length_of_Data	8 bits	
Definition	1 bit	
Operation	1 bits	
Power_Saving_Class_ID	6 bits	
If (Operation = 1) {		
Start_frame_number	6 bits	
Reserved	2 bits	
} else {		
REQ-duration	8 bits	
}		
If (Definition = 1) {		
Power_Saving_Class_Type	2 bits	
Direction	2 bits	
initial-sleep window	8 bits	
listening window	8 bits	
final-sleep window base	10 bits	
final-sleep window exponent	3 bits	
TRF-IND required	1 bits	
Traffic_triggered_wakening_flag.	1 bits	
Reserved	1 bit	
If(TRF-IND required) {		
SLPID	10 bits	
Reserved	2 bits	
}		
Number_of_CIDs	4 bits	
for (i = 0; i < Number_of_CIDs; i++) {		
CID	16 bits	
}		
If (SHO or FBSS capability enabled) {		
Maintain Active Set and Anchor BS ID	1 bit	
If (Active Set and Anchor BS ID maintained) {	3 bits	
SHO/FBSS duration (s)		
}		
}		
}		
If (Operation = 1) {		
Power Saving Class TLV encoded information		
}		

Padding	Variable	If needed for alignment to byte boundary
}		
TLV encoded information		
}		

Parameters shall be as follows:

Length_of_Data

Number of bytes in following specification of Power Saving Class

Definition

1 = Definition of Power Saving Class present

Operation

1 = Activation of Power Saving Class

0 = Deactivation of Power Saving Class (for types 1 and 2 only; used only with Definition = 0)

Power_Saving_Class_ID

Assigned Power Saving Class identifier. The ID shall be unique within the group of Power Saving Classes associated with the MSS. This ID may be used in further MOB_SLP-REQ/RSP messages for activation / deactivation of Power Saving Class

Start_frame_number

Start frame number for first sleep window

REQ-duration

Waiting value for the MOB-SLP-REQ message re-transmission (measured in MAC frames)

Power_Saving_Class_Type

Requested Power Saving Class type

Direction

Defined the directions of the class's connections:

00 = Un-specified. Each connection has its own direction assigned during connection creation. Can be DL or UL.

10 = Uplink direction (for management connections only)

01 = Downlink direction (for management connections only)

11 = Reserved

Listening interval

Assigned Duration of MSS listening interval (measured in frames). For Power Saving Class type 3 it is not relevant and must be encoded as 0

Initial-sleep window

Assigned initial duration for the sleep window (measured in frames). For Power Saving Class type 3 it is not relevant and must be encoded as 0

Final-sleep window base

Assigned final value for the sleep interval (measured in frames). For Power Saving Class type 2 it is not relevant and must be encoded as 0. For Power Saving Class type 3 it is the base for duration of single sleep window requested by the message

Final-sleep window exponent

Assigned factor by which the final-sleep window base is multiplied in order to calculate the final-sleep window. The following formula is used:

final-sleep window = final-sleep window base $\times 2^{(\text{final-sleep window exponent})}$

For Power Saving Class type 2 it is the exponent for the duration of single sleep window requested by the message

TRF-IND_Required

For Power Saving Class Type 1 only.

1 = BS shall transmit at least one TRF-IND message during each listening window of the Power Saving Class. This bit shall be set to 0 for another types

Traffic_triggered_wakening_flag (for Type 1 only)

1 = Power Saving Class shall be deactivated if traffic appears at the connection as described in 6.3.19.2.

0 = Power Saving Class shall not be deactivated if traffic appears at the connection as described in 6.3.19.2.

SLPID

This is a number assigned by the BS whenever an MSS is instructed to enter sleep-mode. This number shall be unique in the sense that it is assigned to a single MSS that is instructed to enter sleep-mode. No other MSS shall be assigned the same number while the first MSS is still in sleep-mode.

Number_of_CIDs

In case the message is sent on Basic connection of certain MSS, Number_of_CIDs = 0 means that all CIDs associated with the MSS are included into the class

CID

CIDs of all connections comprising the Power Saving Class. This list shall contain either unicast connections or multicast connections or management connections, but not combination of connections of different types. If Basic CID is encoded, it means that all MSS connections are included in a single class. CID = 0 is reserved for management operations. In case the message is sent on Basic connection of certain MSS, CID = 0 denotes set of all management connections associated with the MSS

Power Saving Class TLV encoded information

May contain the following TLVs:

Next Periodic Ranging

This value indicates the offset of frame in which MSS shall be ready to perform a periodic ranging with respect to the frame where MOB_SLP-RSP is transmitted.

The MOB_SLP-RSP shall include the following parameters encoded as TLV tuples:

HMAC Tuple (see 11.1.2)

The HMAC Tuple shall be the last attribute in the message

[In 6.3.2.3.5 Ranging Request (RNG-REQ) message, page 20, line 50, add the following sentence as]:

The following parameter may be included in RNG_REQ message when the MSS is attempting to perform handover and needs to inform Target BS of its preference to continue in Sleep Mode after handover to Target BS.

Power Saving Class Parameters

Compound TLV to specify Power Saving Class operation.

[In 6.3.2.3.6 Ranging Responset (RNG-RSP) message, page 22, line 38, add the following sentence as]:

The following parameter may be included in RNG_REQ message when the MSS is attempting to perform handover and needs to inform Target BS of its preference to continue in Sleep Mode after handover to Target BS.

Power_Saving_Class_Parameters

Compound TLV to specify Power Saving Class operation.

[Add new section, page 308 line 60]

11.7.2. SLP-RSP Message Encodings

Name	Type (1 byte)	Length	Value (Variable-length)
Next Periodic Ranging	21	2	This value indicates offset of the frame in which the periodic ranging will be performed with respect to the frame where MOB_SLP-RSP is transmitted. If MSS receives MOB_SLP-RSP message with 'Next Periodic Ranging' = 0, it shall deactivate all active Power Saving Classes and return to Normal Operation.

[Add one more TLV to Table 362a—RNG-REQ Message Encodings, page 284, line 20]

Name	Type (1 byte)	Length	Value (Variable-length)
Power_Saving_Class_Parameters	21	Variable	Compound TLV to specify Power Saving Class definition and/or operation

Power_Saving_Class_Parameters Value field is composed from a number of encapsulated TLV fields as specified in Table MMM.

Table MMM.

Name	Type (1 byte)	Length	Value (Variable-length)

Flags	1	1	<p>Bit 0: Definition 1 = Definition of Power Saving Class present</p> <p>Bit 1: Operation (RNG-RSP only) 1 = Activation of Power Saving Class 0 = Deactivation of Power Saving Class (for types 1 and 2 only)</p> <p>Bit 2: TRF-IND_Required For Power Saving Class Type 1 only. 1 = BS shall transmit at least one TRF-IND message during each listening window of the Power Saving Class. This bit shall be set to 0 for another types</p> <p>Bits 3-7: reserved</p>
Power_Saving_Class_ID	2	1	Assigned Power Saving Class identifier Not used for RNG-REQ message
Power_Saving_Class_Type	3	1	Power Saving Class Type as specified in 6.3.2.3
Start_frame_number	4		Start frame number for first sleep window Not used for RNG-REQ message
initial-sleep window	5	1	Initial-sleep window
listening window	6	1	Assigned Duration of MSS listening interval (measured in frames)
final-sleep window base	7	1	Assigned final value for the sleep interval (measured in frames) - base
final-sleep window exponent	8	1	Assigned final value for the sleep interval (measured in frames) - exponent
SLPID	9	1	A number assigned by the BS whenever an MSS is instructed to enter sleep-mode
CID	10	2	CID of connection to be included into the Power Saving Class. There may be several TLVs of this type in a single compound Power_Saving_Class_Parameters TLV
Direction	11	1	Direction for management connection which is added to Power Saving Class

[Add one more TLV to Table 365a—RNG-RSP Message Encodings, page 285, line 60]

Name	Type (1 byte)	Length	Value (Variable-length)
Power_Saving_Class_Parameters		Variable	Compound TLV to specify Power Saving Class definition and/or operation

Power_Saving_Class_Parameters Value field is composed from a number of encapsulated TLV fields as specified in Table MMM.

[Add new section, page 17, line 40]

6.3.2.1.6 Sleep Control Headers

Bandwidth request and Sleep Control Header is sent by the MSS to request activation / deactivation of certain Power Saving Class. The message also indicates total transmission demand at the MSS that may be used by the BS for the purpose of scheduling.

Syntax	Size	Notes
MOB_SLP-DLC_Message_Format() {		
HT	1 bit	Encoded as 1b
EC	1 bit	Encoded as 0b
Type	3 bits	Encoded as 000b
TD	11 bits	Total transmission demand at the MSS in units of 256 bytes
Basic CID	16 bits	Basic CID of the MSS
Power Saving Class ID	6 bits	Power Saving Class ID
Operation	1 bits	= 1 to activate Power Saving Class = 0 to deactivate Power Saving Class
Reserved	1 bits	
HCS	8 bits	
}		

The following message is sent by BS to activate / deactivate certain Power Saving Class. The requested operation is effective starting from the next frame after the one where the message was transmitted.

Syntax	Size	Notes
MOB_SLP-ULC_Message_Format() {		
HT	1 bit	Encoded as 1b
EC	1 bit	Encoded as 0b
Type	3 bits	Encoded as 100b
final-sleep window exponent	3 bits	For Power Saving Class Type 3 only: assigned factor by which the final-sleep window base is multiplied in order to calculate the duration of single sleep window requested by the message
final-sleep window base	10 bits	For Power Saving Class Type 3 only: the base for duration of single sleep window requested by the message
Start Frame Number	6 bits	Number of bytes requested
Power Saving Class ID	6 bits	Power Saving Class ID
Operation	1 bits	= 1 to activate Power Saving Class = 0 to deactivate Power Saving Class
Reserved	1 bits	
CID	16 bits	Basic CID of the MSS
HCS	8 bits	
}		

