

Project	IEEE 802.16 Broadband Wireless Access Working Group < http://ieee802.org/16 >	
Title	Correction to Section 8.4.8.3 (Figure 232—Illustration of STC)	
Date Submitted	2004-11-11	
Source:	Nageen Himayat, Shilpa Talwar, Hassan Yaghoobi	mailto: nageen.himayat@intel.com mailto: shilpa.talwar@intel.com mailto:hassan.yaghoobi@intel.com
	Intel Corporation CHP3-105 350 East Plumeria Dr. San Jose, CA 95134	
Re:	IEEE 802.16e/D5	
Abstract	Proposed Correction to Section 8.4.8.3 (Figure 232). Figure 232 related to space time coding is inconsistent with Figure 244 of 802.16d D5. We propose that Figure 232 be aligned with 802.16d D5.	
Purpose	802.16e Sponsor Ballot	
Notice	This document has been prepared to assist IEEE 802.16. It is offered as a basis for discussion and is not binding on the contributing individual(s) or organization(s). The material in this document is subject to change in form and content after further study. The contributor(s) reserve(s) the right to add, amend or withdraw material contained herein.	
Release	The contributor grants a free, irrevocable license to the IEEE to incorporate material contained in this contribution, and any modifications thereof, in the creation of an IEEE Standards publication; to copyright in the IEEE's name any IEEE Standards publication even though it may include portions of this contribution; and at the IEEE's sole discretion to permit others to reproduce in whole or in part the resulting IEEE Standards publication. The contributor also acknowledges and accepts that this contribution may be made public by IEEE 802.16.	
Patent Policy and Procedures	The contributor is familiar with the IEEE 802.16 Patent Policy and Procedures < http://ieee802.org/16/ipr/patents/policy.html >, including the statement "IEEE standards may include the known use of patent(s), including patent applications, provided the IEEE receives assurance from the patent holder or applicant with respect to patents essential for compliance with both mandatory and optional portions of the standard." Early disclosure to the Working Group of patent information that might be relevant to the standard is essential to reduce the possibility for delays in the development process and increase the likelihood that the draft publication will be approved for publication. Please notify the Chair < mailto:chair@wirelessman.org > as early as possible, in written or electronic form, if patented technology (or technology under patent application) might be incorporated into a draft standard being developed within the IEEE 802.16 Working Group. The Chair will disclose this notification via the IEEE 802.16 web site < http://ieee802.org/16/ipr/patents/notices >.	

Correction to Section 8.4.8.3 (Figure 232)

Figure 232 in Section 8.4.8.3 of 802.16e D5, illustrating the use of transmit diversity, is inconsistent. The figure, as reproduced below, shows that space-time coding is carried out before the sub-channel mapping operation. Whereas Figure 244 in section 8.4.8.1 in 802.16d D5, shows that STC encoding is carried out after the sub-carrier mapping operation. We propose that Figure 232 be corrected according to Figure 244 of 802.16d D5.

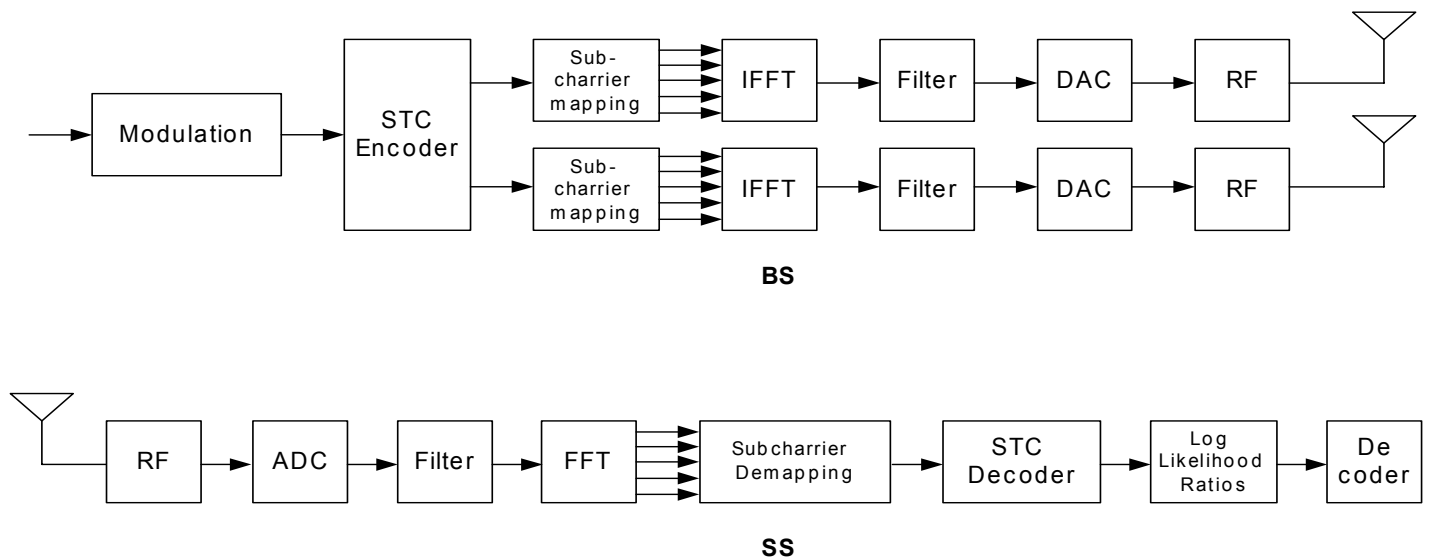

Figure 232---Illustration of STC for Optional Zones in DL

Figure 244 in section 8.4.1 of 802.16d D5 is shown below.

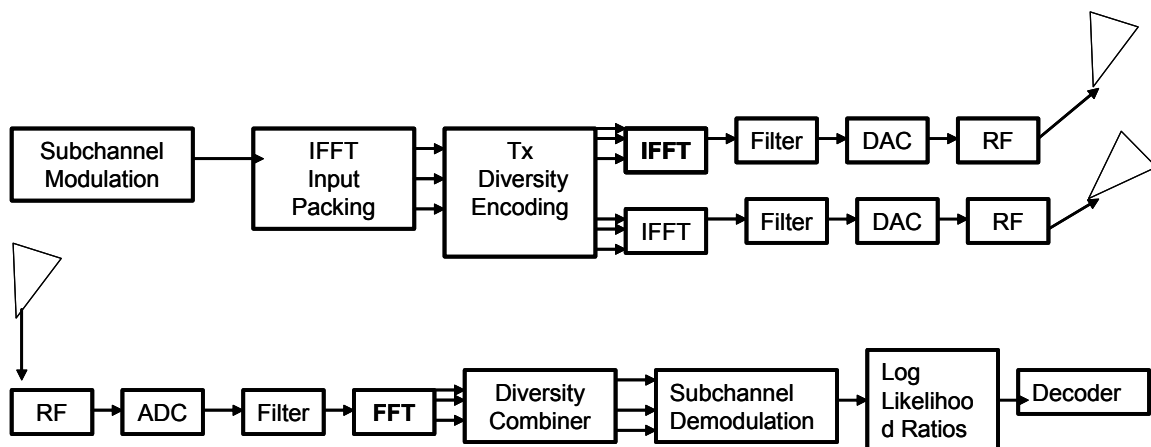

Figure 244 – Illustration of STC