

# Network Assisted GPS (N-GPS) Positioning in WiMAX/16m

Document Number: IEEE C802.16m-08/1105

Date Submitted: 2008-09-0, revised on 2008-09-08

Source: Shu Wang, Ki-Dong Lee and Byung K. Yi

LG Electronics Mobile Research USA

Email: [swang@lge.com](mailto:swang@lge.com) Phone: +1-858-635-5305

Venue:

IEEE Session #57, Kobe.

Base Contributions:

None

Re: Call for Contributions on Project 802.16m System Description Document (SDD): MAC aspects of enhanced LBS

Purpose: Discussion and Approval

Notice:

*This document does not represent the agreed views of the IEEE 802.16 Working Group or any of its subgroups. It represents only the views of the participants listed in the "Source(s)" field above. It is offered as a basis for discussion. It is not binding on the contributor(s), who reserve(s) the right to add, amend or withdraw material contained herein.*

Release:

The contributor grants a free, irrevocable license to the IEEE to incorporate material contained in this contribution, and any modifications thereof, in the creation of an IEEE Standards publication; to copyright in the IEEE's name any IEEE Standards publication even though it may include portions of this contribution; and at the IEEE's sole discretion to permit others to reproduce in whole or in part the resulting IEEE Standards publication. The contributor also acknowledges and accepts that this contribution may be made public by IEEE 802.16.

Patent Policy:

The contributor is familiar with the IEEE-SA Patent Policy and Procedures:

<http://standards.ieee.org/guides/bylaws/sect6-7.html#6> and

<http://standards.ieee.org/guides/opman/sect6.html#6.3>.

Further information is located at <http://standards.ieee.org/board/pat/pat-material.html> and <http://standards.ieee.org/board/pat>.

# **Network Assisted GPS (N-GPS) Positioning in WiMAX/16m**

Shu Wang, Ki-Dong Lee and Byung K. Yi  
**LG Electronics Mobile Research USA**

# Outline

- LBS Requirement in 802.16m SRD
- Introduction to LBS
  - FCC E911 and EU E112
  - Existing Positioning Technology Comparison
- GPS Positioning Principle and Error Sources
- A Snapshot of Assisted GPS Positioning
- GPS Positioning Assistance in WiMAX
  - Assistance GPS Overview
  - Network Assisted GPS I: GPS Assistance Zone
  - Network Assisted GPS II: Enhanced GPS TLV
  - Network Assisted GPS III: Enhanced LBS Management
  - Other Assistance
  - Performance
- Proposed ToC
- Proposed SDD Text

# Positioning Requirements in 802.16m SRD

- **7.6 Location-based services performance**
  - IEEE 802.16m systems (this may include MS, BS, or both depending on the solution) should provide support for LBS. IEEE 802.16m systems should satisfy the requirements in Table 15.

Feature	Requirement	Comments
Location determination latency	< 30 s	
Handset-based position accuracy (in meters)	50 meter (67%-tile of the CDF of the position accuracy) 150 meter (95%-tile of the CDF of the position accuracy)	Need to meet E911 Phase II Requirements
Network-based position accuracy (in meters)	100 meter (67%-tile of the CDF of the position accuracy) 300 meter (95%-tile of the CDF of the position accuracy)	

**Table 15–Location-based service requirements**

# Introduction (1/2): E911 and E112

- **FCC Enhanced 911**

- **Phase I:** Within six months of a request by a Public Safety Answer Point (PSAP), the carrier shall provide PSAPs with the telephone number and the cell site location for this 911 call.
- **Phase II:** Within six months of a request by a PSAP, more precise location information, such as the latitude and longitude of the caller, shall be provided.
  - For network-based solutions, 100 meters for 67%; 300 meters for 95%.
  - For handset-assisted solutions, 50 meters for 67%; 150 meters for 95%.
- **Phase II Compliance Status:** In August 2007, FCC fined three carriers, Sprint Nextel, Alltel and US Cellular, \$2.8M for failing to meet the mandate (December 2005) to provide E911 service to 95 percent of their networks.

- **EU Location-Enhanced 112**

- In 2000, the EU launched activities for enhanced 112 (E-112) and CGALIES (the Coordination Group on Access to Location Information for Emergency Services) is initiated.
- In September 2002, an EMTEL ad hoc group under the ETSI OCG (Operational Co-ordination Group) was set up to look at standardization requirements.
- In July 2003, the EU issued a Recommendation for the Europe-wide implementation of the location-enhanced 112.

- **Mission Unaccomplished.**

- It is not a easy job to completely satisfy the mandates alone.
- LBS is also believed to be a key feature of next generation mobile standards including 16m.
- It is important for 16m to provide a simple and efficient scheme assisting GPS-based positioning.
  - GPS-based positioning is known to be one of the most reliable positioning schemes with the best coverage and highest accuracy.
  - With close to 1.18 billion mobile handsets sold in 2007 and an expected **1.8 billion in 2012**, close to 30% of existing worldwide mobiles are GPS-capable in 2008. This number is increasing every year and predicted to more than **35% in 2012** by Texas Instrument and gpsWorld.
  - ABI Research forecasts that global revenue from location-based services will hit **\$13.3 billion by 2013**, compared with \$515 million in 2007.

# Introduction (2/2): Existing Technologies Comparison

	Attributes	Network	Handset	Accuracy*
<b>Cell ID</b>	obtains Cell ID based on pilot measurements	All	All	100m-3km. Depends on cell size and density
<b>Cell ID + TA</b>	combines Cell ID with time advance	GSM	All	Default is 500m. Depends on bandwidth and system resolutions.
<b>EFLT</b>	measures the forward link pilot timing.	CDMA	All	250-350m
<b>AOA</b>	measures the angle of arrival by base stations	All	All	100-200m
<b>EOTD</b>	measures time difference by network and mobiles.	GSM	upgrade	50-200m
<b>AFLT</b>	measures the forward link pilot timing.	CDMA	upgrade	50-200m
<b>U-TDOA</b>	Network measures the timing difference	All	All	50 – 100 m.
<b>GPS/A-GPS</b>	utilize the GPS receivers embedded in the handsets and network.	All	upgrade	5 - 30m

\*The accuracy data are compiled from the claims of various technology providers.

# The Principles of GPS Positioning

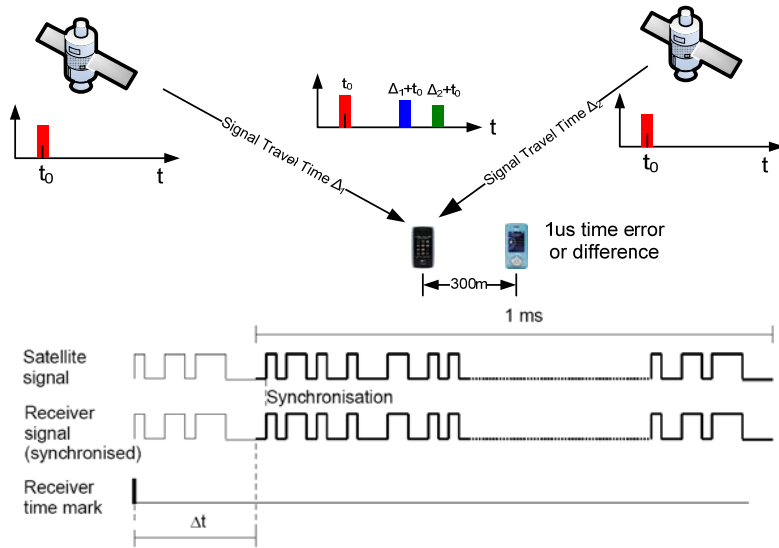

**Telemetry Word (TLM)**  
30 bits / 0.6s

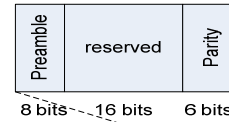

**Handover Word (HOW)**  
30 bits / 0.6s

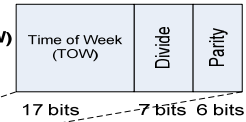

**Subframe (TLM)**  
300 bits / 6.0s



**Frame**  
1500 bits / 30s

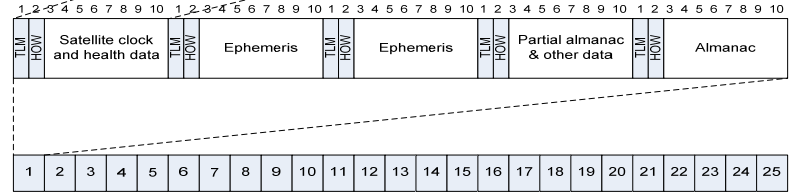

**25 Frames**  
37500 bits / 12.5 min

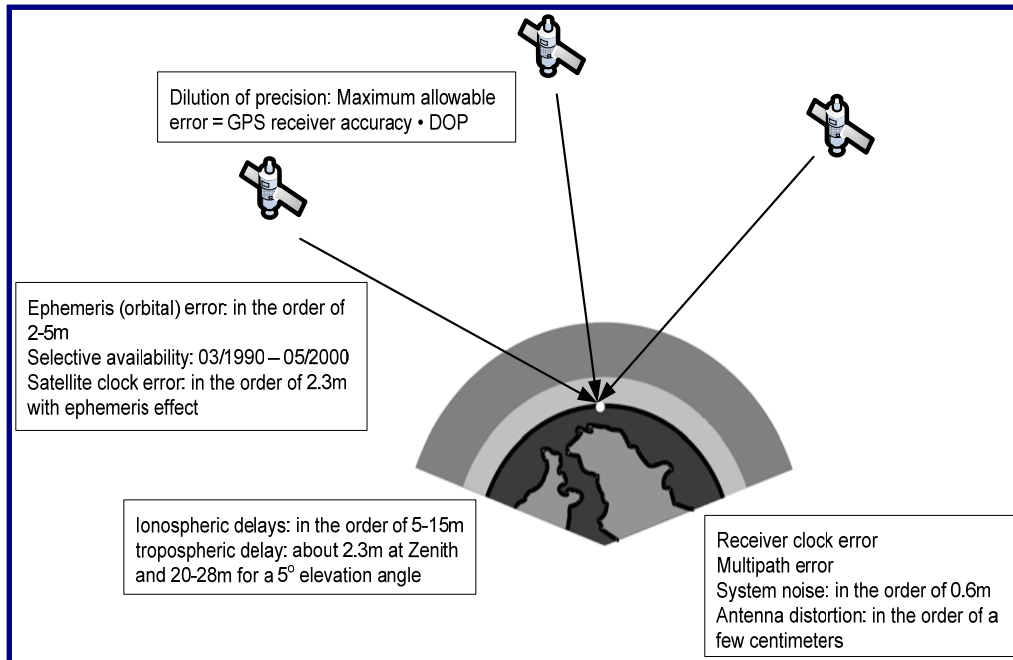

## GPS Messages

- **TLM – Telemetry:** 30 bits, sent at the beginning of each frame.
  - It is used for data synchronization and satellite maintenance.
  - They are usually constant for any one satellite for a long period of time.
- **HOW – Handover Word:** 30 bits, sent after TLM.
  - It indicates the time at the beginning of the next subframe.
  - It also contains a sub-frame ID, some flags and parity bits.
- **Ephemeris:** It is sent in each frame by each satellite.
  - It may take the GPS receiver up to 30 seconds to acquire Ephemeris.
- **Almanac:** It is spread out over all 25 frames of the message.
  - For receiving the complete Almanac, the GPS receiver may need about 12.5 minutes.

# Assisted GPS Positioning

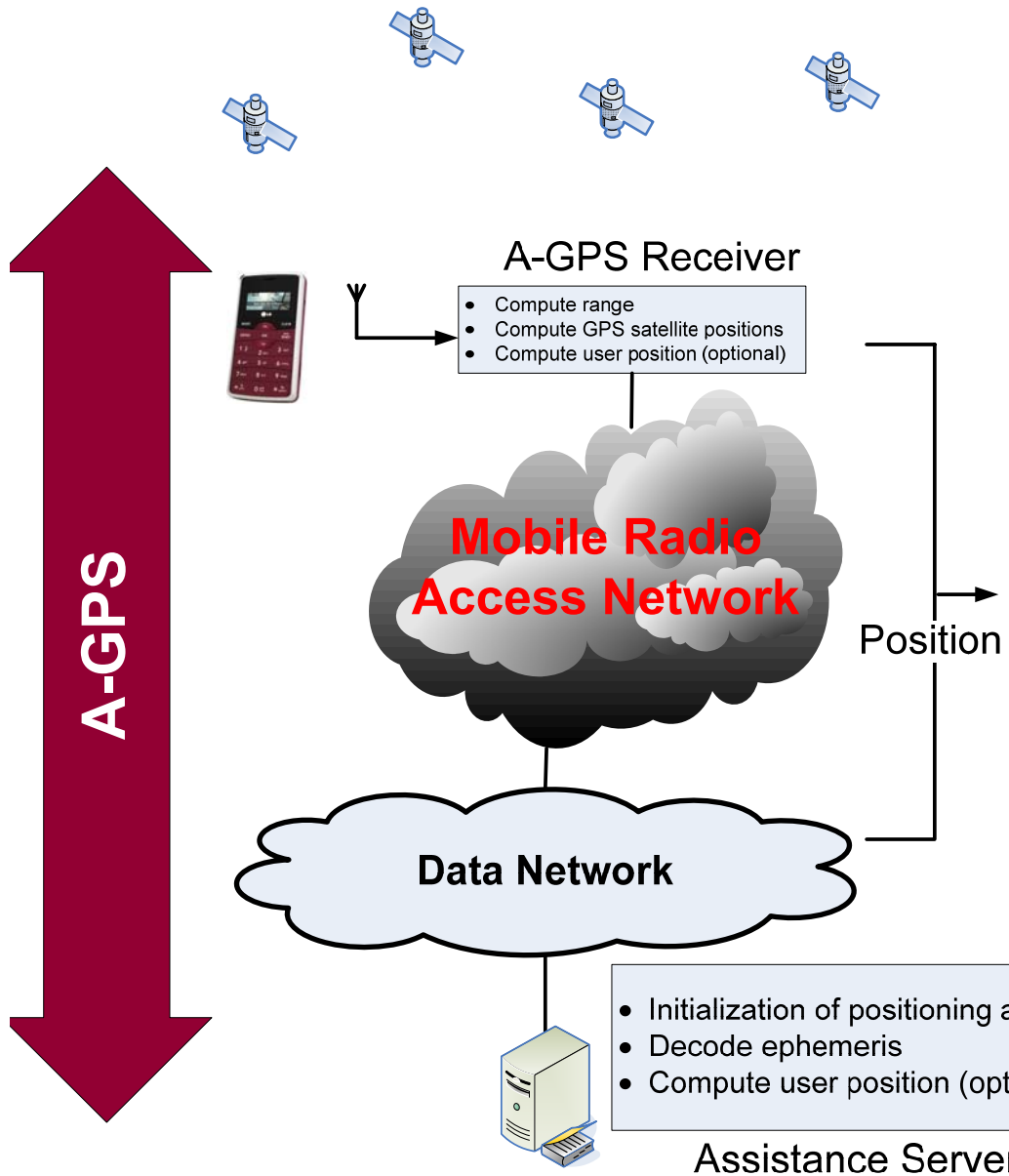

- A-GPS with **assistance server** were developed to enhance the positioning performance of a GPS receiver and satisfy FCC's E911 mandate.
  - It was firstly come out by Bell Labs before the 1996 FCC ruling.
- **Assistance server** can increase the capability of a stand-alone receiver.
  - It can roughly locate mobiles along by itself.
  - It can supply more GPS orbital data to the mobile.
  - It has better knowledge of atmosphere conditions and other errors as well as better augmentation capability.
- With **assistance server**, A-GPS help improve positioning in terms of
  - Location accuracy: the positioning error.
  - Yield: the positioning success rate.
  - Time to fix: the time for positioning.
  - Battery consumption: power consumption for positioning.
  - Mobile device cost.

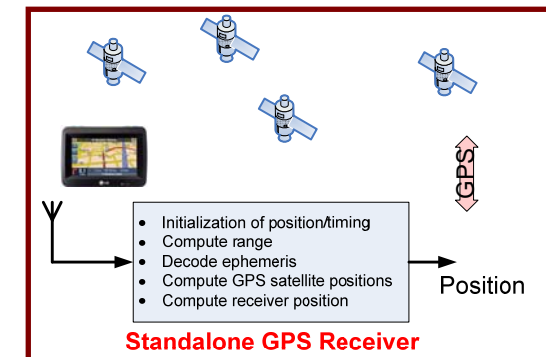



# Existing Assistance in 16e

Field	Size	Description
GPS Second	12 bits	GPS second, modulo 2048
GPS Second fraction	28 bits	GPS second fraction
GPS time accuracy	8 bits	GPS Time Accuracy For unsigned integer values 0x00-0x3F: $\log_2$ (Time error in pico seconds). For unknown accuracy in time error, 0xFF. Values 0x40-0xFE not allowed.

Name	Type	Length (bytes)	Value
Frequency information	5	1	BS transmit frequency accuracy in ppm. For values in range 0x00-0xFE, frequency root mean square error is (value+1)*0.01 ppm. For value 0xff, the MS shall interpret this as max frequency accuracy uncertainty for that profile, see subclause 12.

- The GPS Time TLV informs the receiving MS of the precise time at which the BS's First Frame of the current epoch has been transmitted, which the MS may use to calibrate its own internal clock in reference to the GPS time standard.
  - The GPS Time TLV is used if the BS's frame time is synchronized with the GPS clock. This may be particularly valuable for determining GPS satellite signal search windows in mobiles equipped to detect GPS satellites.
  - GPS second and second fraction allow the MS to use DL Frame arrival times as timing signals aligned with GPS time.
  - GPS Time Accuracy aids the MS in estimating how much error with respect to GPS time the BS may have when using this calibration.
- The GPS Frequency TLV shall be used to provide the frequency accuracy information.
  - BS transmit frequency accuracy in ppm.
  - For values in range 0x00-0xFE, frequency root mean square error is (value+1)\*0.01 ppm.
  - For value 0xff, the MS shall interpret this as max frequency accuracy uncertainty for that profile.

# Network-Assisted GPS: It is the network!

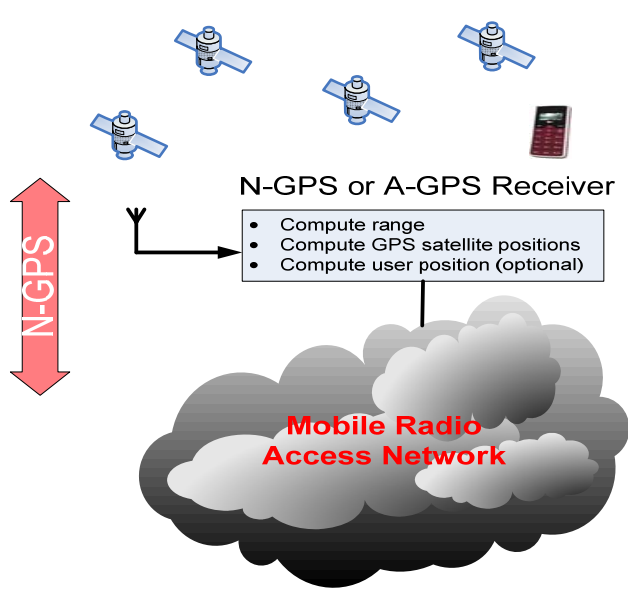

- GPS assistance data is sent through **control plan** instead of user plan.
- **No** additional data channel setup overhead required.
- **No** additional authentication or access control required.
- **More reliable** than layer-3 A-GPS approaches.
- **More efficient** if the assistance data is periodically broadcasted.
- It is fully compatible with most existing A-GPS receivers.

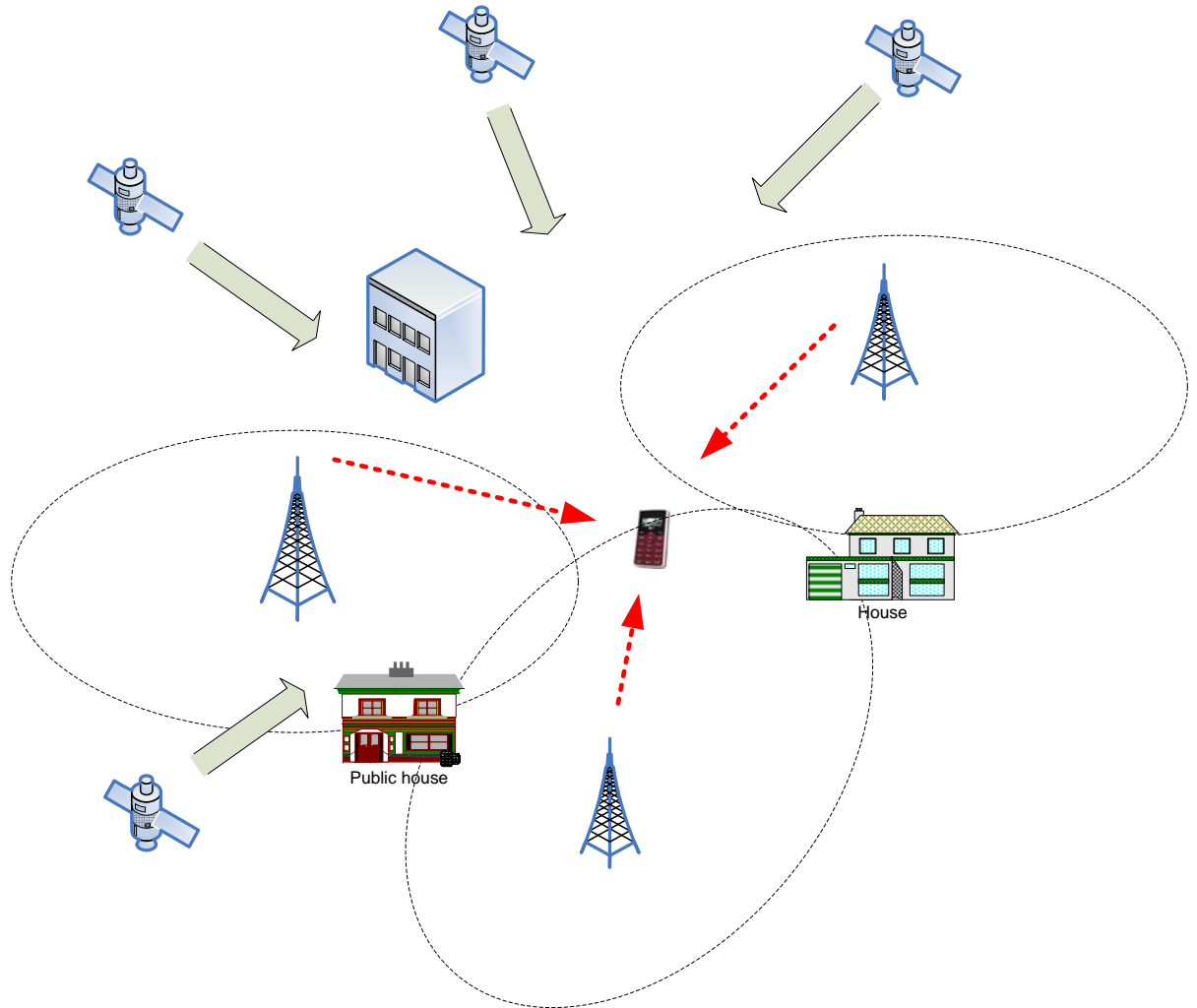

Each base station tracks GPS messages by its own.  
No addition overhead to the backbone.

# Network Assisted GPS (1/3): GPS Assistance Zone

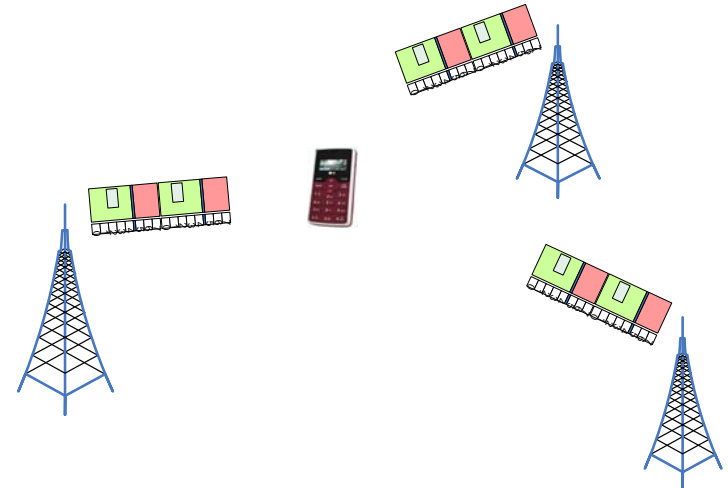
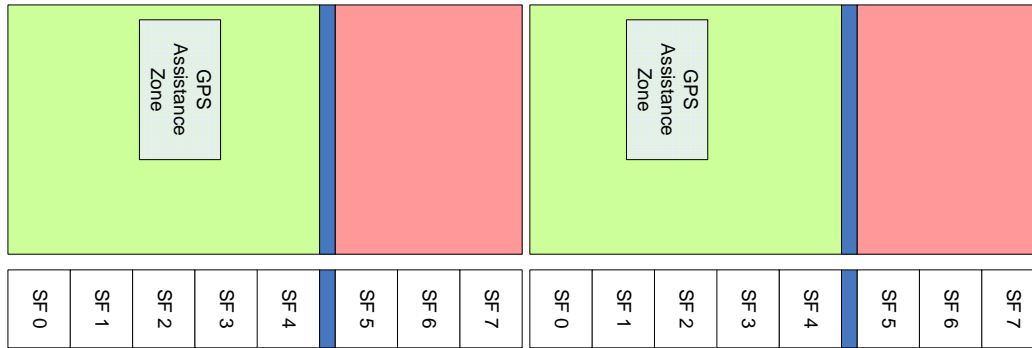

- With the assistance of GPS assistance zone and SFN broadcasting, it is easy for a GPS-capable mobile to receive the assistance from WiMAX network.
- The important assistance information for GPS positioning includes
  - Almanac: It is spread out over all 25 frames of the message.
    - For receiving the complete Almanac, the GPS receiver may need about **12.5 minutes**.
    - **A detailed explanation of GPS Almanac data is in the appendix.**
  - Ephemeris: It is sent in each frame by each satellite.
    - It may take the GPS receiver up to **30 seconds** to acquire Ephemeris.
- The information of Ephemeris and Almanac can be broadcast by capable base station within LBS zone.

## Network Assisted GPS (1/3): GPS Assistance Zone (Con'd)

Type	Length	Value	Comment
XXX	1	0: No available LBS Zone. 1: LBS Zone in Serving BS only 2: LBS Zone in a multiple BS zone	

- This TLV indicates whether the LBS Zone service is being requested or provided for the connection that is being setup.
  - A value of 1 indicates that an MBS service limited to the serving BS is being requested
  - and a value of 2 indicates multi-BS-MBS is being requested.
- If MS or BS wants to initiate MBS service, DSA-REQ with MBS service TLV shall be used. The DSA-RSP message shall contain the acceptance or rejection of request and if there is no available LBS, LBS service value shall be set to 0.

## Network Assisted GPS (2/3): Enhanced GPS TLV

Name	Type	Length (Byte)	Value
<b>GPS Almanac TLV</b>	<b>XXX</b>	<b>Variable</b>	<b>GPS Almanac Data</b>
Field Bit-Map	XXX.0	2	It signaling which field of GPS Almanac is available.
GPS Satellite ID	XXX.1	1	PRN of the SVN, Range: 0 to 32; Accuracy: 1
Satellite Health	XXX.2	1	000=usable; Range: 0 to 63; Accuracy: None
Eccentricity	XXX.3	3	This shows the amount of the orbit deviation from circular (orbit). It is the distance between the foci divided by the length of the semi-major axis (our orbits are very circular). Range: 0.0 to 0.03; Accuracy: 4.7E-7
Time of Applicability (s)	XXX.4	3	The number of seconds in the orbit when the almanac was generated. Kind of a time tag. Range: 0 to 602112; Accuracy: 1
Orbital Inclination (rad)	XXX.5	3	The angle to which the SV orbit meets the equator (GPS is at approx. 55 degrees). Roughly, the SV's orbit will not rise above approx. 55 degrees latitude. The number is part of an equation: $\# = \pi/180 =$ the true inclination Range: -9.999999E-2 to +9.999999E-2; Accuracy: 1.91E-6
Rate of Right Ascen (r/s)	XXX.6	4	Rate of change in the measurement of the angle of right ascension as defined in the Right Ascension mnemonic. Range: -9.999999E-7 to +9.999999E-7; Accuracy: 3.6E- 12
SQRT(A) (m <sup>1/2</sup> )	XXX.7	2	This is defined as the measurement from the center of the orbit to either the point of apogee or the point of perigee. Range: 79.0 to 9999.99999; Accuracy: 4.8E-4

## Network Assisted GPS (2/3): Enhanced GPS TLV (Con'd)

Name	Type	Length (Byte)	Value
Right Ascen at Week(rad)	XXX.8	3	Geographic Longitude of the Ascending Node of the Orbit Plane at the Weekly Epoch Range: -9.999999E-7 to +9.999999E-7; Accuracy: 3.6E- 12
Argument of Perigee(rad)	XXX.9	3	An angular measurement along the orbital path measured from the ascending node to the point of perigee, measured in the direction of the SV's motion. Range: -1.0 to +1.0; Accuracy: 1.1E-7
Mean Anom(rad)	XXX.10	3	Angle (arc) traveled past the longitude of ascending node (value= 0-180 degrees or 0-negative 180 degrees). If the value exceeds 180 degrees, subtract 360 degrees to find the mean anomaly. When the SV has passed perigee and heading towards apogee, the mean anomaly is positive. After the point of apogee, the mean anomaly value will be negative to the point of perigee. Range: -1.0 to +1.0; Accuracy: 1.1E-7
Af0(s)	XXX.11	3	SV clock bias in seconds Range: -9.9999E-4 to +9.9999E-4; Accuracy: 9.5E-7
Af1(s/s)	XXX.12	3	SV clock Drift in seconds per seconds Range: -9.9999E-9 to +9.9999E-9; Accuracy: 3.6E- 12
GPS Week Number:	XXX.13	2	GPS week (0000-1024), every 7 days since 22 Aug 1999 Range: 0 to 1023; Accuracy: 1
Reserved	XXX.14 – XXX.16	N/A	N/A

- The including of the field, “Field Bit-Map”, is for providing a mechanism for delivering only necessary Almanac data fields.
  - The length of “Field Bit-Map” is 2 bytes and 16 bits.
  - Each bit is mapped to each Almanac data field. For example, the 13<sup>th</sup> MSB of “Field Bit-Map” is mapped to XXX.13, GPS Week Number.
  - If the bit field is “0”, it means this field is not included. If it is “1”, it is included in the delivery.

# Network Assisted GPS (3/3): Enhanced LBS Management

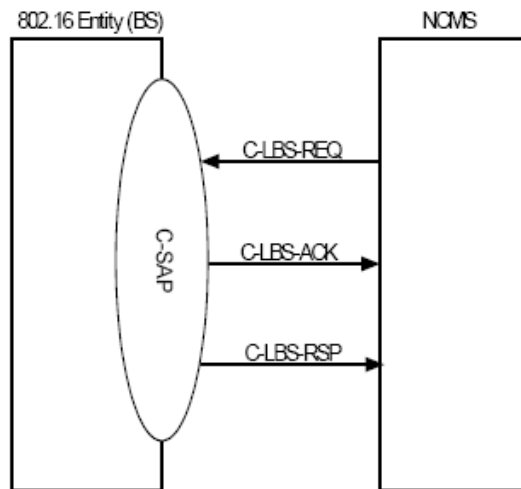

- **C-LBS-REQ** (
  - Operation\_Type: Get,
  - Destination: BS,
  - Attribute\_List:
    - MS MAC Address,
    - LBS Parameter Types)
- **C-LBS-RSP** (
  - Operation\_Type: Get,
  - Destination: NCMS,
  - Attribute\_List:
    - MS MAC Address,
    - Requested LBS Parameters[]
      - BSID,
      - CINR mean,
      - RSSI mean,
      - D-TDOA,
      - U-TDOA,
      - GPS Orbital Data)
- GPS Orbital Data, which may include Almanac data, Ephemeris data or other assisting data.

# Comparison of GPS, N-GPS and A-GPS

Feature	GPS	N-GPS	A-GPS
Accuracy	Good	Better	Best
Yield	Good	Better	Best
TTFF	Slow	Fast	Faster
Additional Carrier Investment	None	None	Yes.
Protocols	Open	Open	Propriety
Access to Network	No Control Channel Access	<b>Control Channel Access Only</b>	Control Channel Access
	No Traffic Channel Access	No Traffic Channel Access	Traffic Channel Access



# GPS with Assistance: TTFF Gain

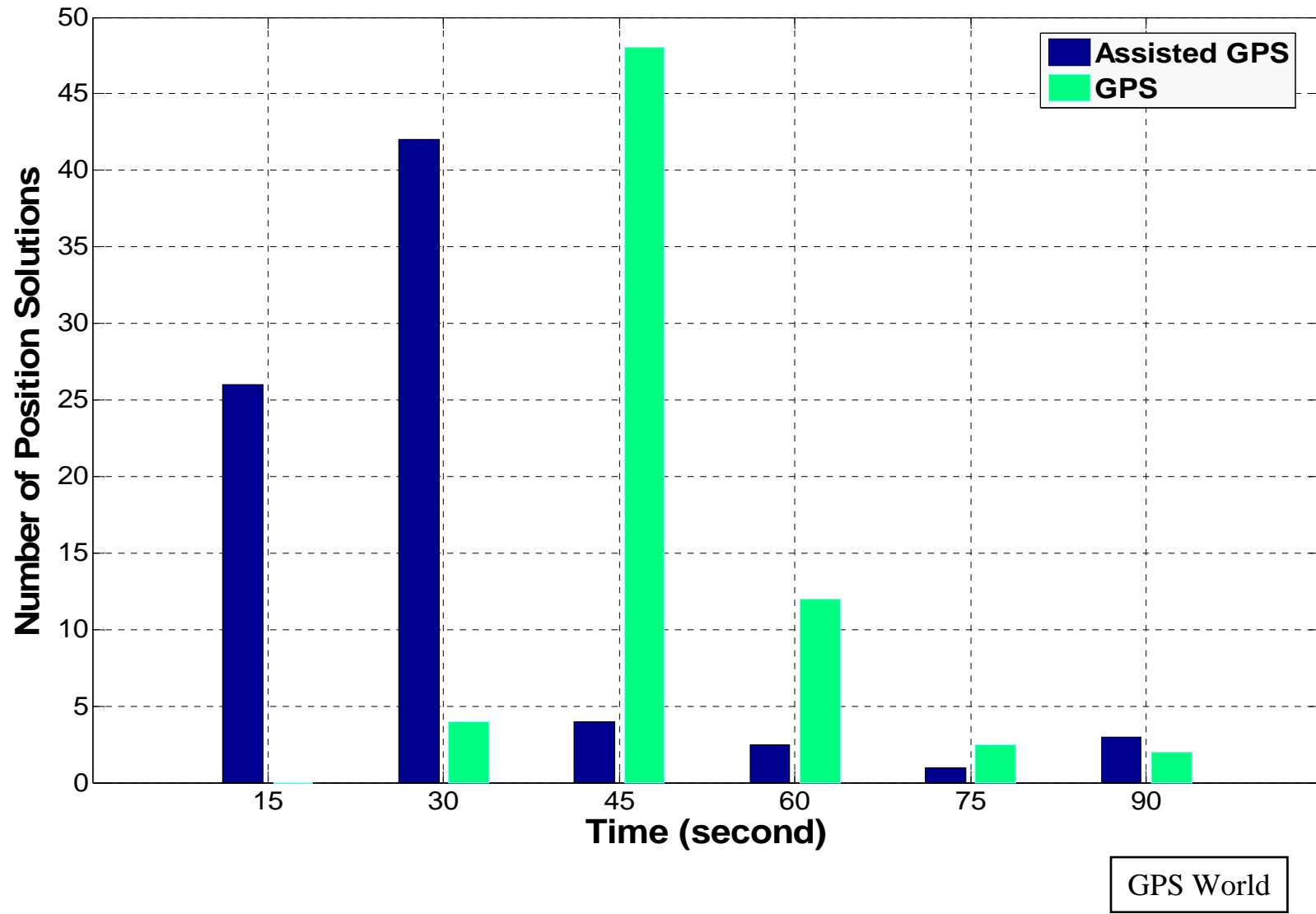

# Other Assistance Topics

- The GPS information can be any of
  - Precise GPS satellite orbit and clock information
    - Reference time
    - Reference location
  - Initial position and time estimate
    - Almanac
    - Acquisition assistance
    - Real-time integrity.
    - Universal Time Co-ordinates
  - Satellite selection and range information
    - Differential GPS (DGPS) corrections
    - Navigation model (contains satellite ephemeris and clock corrections)
    - Ionospheric model
    - UTC model

# Proposed ToC

- **XX. Support for Location Based Services**
  - XX.1. Location Based Services Overview and Protocol Structure
  - XX.3. MAC Layer Support for Location Based Services
    - XX.3.1. Location Based Services (LBS-ADV) message
    - XX.3.2. GPS and Galileo Positioning Assistance
      - XX.3.1. GPS Zone
      - XX.3.2. GPS Almanac TLV
      - XX.3.3. GPS Ephemeris TLV
- **XXX LBS Management**

# Proposed SDD Text

- The orbital description data of GPS satellites is important for GPS-capable mobile to performance GPS based positioning. In addition, the GPS almanac data is generally usable for months. With making GPS almanac data easily available to mobiles from the network, it can enhance the existing support of LBS.
- The delivery of GPS orbital description data, such as Almanac and Ephemeris, to mobiles can be realized by the implementation of GPS zone and GPS TLV.
  - The GPS zone is a special broadcast zone for broadcasting GPS orbital description data.
  - GPS TLV, including GPS Almanac TLV and GPS Ephemeris TLV, is another mechanism assisting mobile to do GPS based positioning.
  - LBS management, where a mobile can request GPS assistance data for LBS.

# Reference

- 1) IEEE 802.16 Broadband Wireless Access Working Group IEEE 802.16m System Requirements. [http://wirelessman.org/tgm/docs/80216m-07\\_002r4.pdf](http://wirelessman.org/tgm/docs/80216m-07_002r4.pdf)
- 2) P802.16Rev2/D4 (April 2008), Part 16: Air Interface for Broadband Wireless Access Systems
- 3) Shu Wang, Jungwon Min and Byung K. Yi, “Location Based Services for Mobiles: Technologies and Standards”, Tutorial#25, IEEE International Conference on Communication (ICC), May 23, 2008, Beijing, China.
- 4) Shu Wang, Jungwon Min, Li-Hsiang Sun, “Enhanced Location Based Support in cdma2000”, 3GPP2 TSG-C NTAH, Osaka, Japan, May 2008.

# Appendix – GPS Almanac Data

# Example: SEM Almanac Data of 4 Satellites for the Week of 09/05/2008

•	2	← The GPS Satellite PRN Number		
•	61	← The GPS Satellite "SVN" reference number		
•	0	← The GPS satellite "average" URA number		
•	8.75091552734375E-03	2.86102294921875E-05	-2.59387888945639E-09	
•	5.15370849609375E+03	-6.53563380241394E-01	8.39705228805542E-01	
•	-4.05330657958984E-02	1.88827514648438E-04	-3.63797880709171E-12	
•	0	← The GPS Satellite Health		
•	9	← The GPS Satellite Configuration		

•	3			
•	33			
•	0			
•	1.11351013183594E-02	-5.10025024414062E-03	-2.56841303780675E-09	
•	5.15364062500000E+03	9.82081413269043E-01	2.69389271736145E-01	
•	-1.45777463912964E-01	2.81333923339844E-04	3.63797880709171E-12	
•	0			
•	9			

•	4			
•	34			
•	0			
•	8.27789306640625E-03	-2.04086303710938E-04	-2.59387888945639E-09	
•	5.15351708984375E+03	-6.47604107856750E-01	1.26119256019592E-01	
•	8.53008031845093E-01	-1.67846679687500E-04	-1.09139364212751E-11	
•	0			
•	9			

•	5			
•	35			
•	2			
•	9.28258895874023E-03	3.08990478515625E-04	-2.55749910138547E-09	
•	5.15364550781250E+03	6.53590559959412E-01	4.04798626899719E-01	
•	7.23199725151062E-01	3.52859497070312E-05	-2.11002770811319E-10	
•	63			
•	9			

- 1) PRN Number:** The satellite PRN number per [ICD-GPS-200](#). This is a required data item as it is the GPS user's primary means of identifying GPS satellites. It is equivalent to the space vehicle identification (SVID) number of the satellite.
- 2) SVN Number:** The satellite "SVN" reference number. This is not a required data item and is normally included only for cross-reference with the operational control system (OCS).
- 3) Average URA Number:** The satellite "average" URA number, with URA number as defined in [ICD-GPS-200](#). This is not an item in the raw almanac file but is based on the average URA value transmitted by this satellite in its subframe 1 data sets.
- 4) Eccentricity:** The satellite almanac orbital "eccentricity" (e) as defined in [ICD-GPS-200](#).
- 5) Inclination Offset:** The satellite almanac orbital "inclination angle offset" (8i) as defined in [ICD-GPS-200](#). This is an item in the raw almanac file and does not include the 0.30 semicircle reference value. This should not be confused with the "lo" term in the satellite ephemeris files.
- 6) Rate of Right Ascension:** The satellite almanac orbital "rate of right ascension" (OMFGADOT) as defined in [ICD-GPS-200](#).
- 7) Square Root of Semi-Major Axis:** The satellite almanac orbital "square root of the semi-major axis" (A1/2 as defined in [ICD-GPS-200](#).
- 8) Longitude of Orbital Plane:** The satellite almanac orbital "geographic longitude of the orbital plane at the weekly epoch" (OMEEGAO) as defined in [ICD-GPS-200](#).
- 9) Argument of Perigee:** The satellite almanac orbital "argument of perigee" ("small omega") as defined in [ICD-GPS-200](#).
- 10) Mean Anomaly:** The satellite @ac orbital "mean anomaly" (MO) as defined in [ICD-GPS-200](#).
- 11) Zeroth Order Clock Correction:** The satellite almanac zeroth order clock correction term (afo) as defined in [ICD-GPS-200](#).
- 12) First Order Clock Correction:** The satellite almanac first order clock correction term (afl) as defined in [ICD-GPS-200](#).
- 13) Satellite Health:** The satellite subframe 4 and 5, page 25 six-bit health code as defined in [ICD-GPS-200](#) expressed in integer form.
- 14) Satellite Configuration:** The satellite subframe 4, page 25 four-bit configuration code as defined in [ICD-GPS-200](#) expressed in integer form.

In reality, the data of 4 GPS satellites may be enough for a first fix. **The Almanac data are stable and can be reused in weeks.**  
<http://www.navcen.uscg.gov/GPS/almanacs.htm>

# Definition of A SEM Almanac

1. **GPS Week Number:** The almanac reference week (VINA) for all almanacs in this \*.AL3 file per [ICD-GPS-200](#)
2. **GPS Time of Applicability:** The almanac reference time (TOA) for all almanacs in this \*.AL3 file per [ICD-GPS-200](#)
3. **PRN Number:** The satellite PRN number per [ICD-GPS-200](#). This is a required data item as it is the GPS user's primary means of identifying GPS satellites. It is equivalent to the space vehicle identification (SVID) number of the satellite.
4. **SVN Number:** The satellite "SVN" reference number. This is not a required data item and is normally included only for cross-reference with the operational control system (OCS).
5. **Average URA Number:** The satellite "average" URA number, with URA number as defined in [ICD-GPS-200](#). This is not an item in the raw almanac file but is based on the average URA value transmitted by this satellite in its subframe 1 data sets.
6. **Eccentricity:** The satellite almanac orbital "eccentricity" (e) as defined in [ICD-GPS-200](#).
7. **Inclination Offset:** The satellite almanac orbital "inclination angle offset" (8i) as defined in [ICD-GPS-200](#). This is an item in the raw almanac file and does not include the 0.30 semicircle reference value. This should not be confused with the "Io" term in the satellite ephemeris files.
8. **Rate of Right Ascension:** The satellite almanac orbital "rate of right ascension" (OMFGADOT) as defined in [ICD-GPS-200](#).
9. **Square Root of Semi-Major Axis:** The satellite almanac orbital "square root of the semi-major axis" (A1/2 as defined in [ICD-GPS-200](#)).
10. **Longitude of Orbital Plane:** The satellite almanac orbital "geographic longitude of the orbital plane at the weekly epoch" (OMEEGAO) as defined in [ICD-GPS-200](#).
11. **Argument of Perigee:** The satellite almanac orbital "argument of perigee" ("small omega") as defined in [ICD-GPS-200](#).
12. **Mean Anomaly:** The satellite @ac orbital "mean anomaly" (MO) as defined in [ICD-GPS-200](#).
13. **Zeroth Order Clock Correction:** The satellite almanac zeroth order clock correction term (af0) as defined in [ICD-GPS-200](#).
14. **First Order Clock Correction:** The satellite almanac first order clock correction term (af1) as defined in [ICD-GPS-200](#).
15. **Satellite Health:** The satellite subframe 4 and 5, page 25 six-bit health code as defined in [ICD-GPS-200](#) expressed in integer form.
16. **Satellite Configuration:** The satellite subframe 4, page 25 four-bit configuration code as defined in [ICD-GPS-200](#) expressed in integer form.

Source: <http://www.navcen.uscg.gov/GPS/almanacs.htm>