

Project	IEEE 802.16 Broadband Wireless Access Working Group < http://ieee802.org/16 >
Title	Proposed FDM structure between Unicast and E-MBS and E-MBS Channel Structure for 802.16m
Date Submitted	January 5, 2009
Source(s)	Shigeo Terabe, Tsuguhide Aoki, Saori Fukushi Toshiba Corporation Voice: +81-428-344266 E-mail: shigeo.terabe@toshiba.co.jp Yong Sun, Toshiba Research Europe Limited Voice : +44-117-9060749 E-mail : Sun@toshiba-trel.com
Re:	Call for Contributions on Project 802.16m System Description Document (SDD)
Abstract	Stage 2 proposes text to complement existing SDD text draft
Purpose	Discussion and Approval
Notice	<i>This document does not represent the agreed views of the IEEE 802.16 Working Group or any of its subgroups.</i> It represents only the views of the participants listed in the "Source(s)" field above. It is offered as a basis for discussion. It is not binding on the contributor(s), who reserve(s) the right to add, amend or withdraw material contained herein.
Release	The contributor grants a free, irrevocable license to the IEEE to incorporate material contained in this contribution, and any modifications thereof, in the creation of an IEEE Standards publication; to copyright in the IEEE's name any IEEE Standards publication even though it may include portions of this contribution; and at the IEEE's sole discretion to permit others to reproduce in whole or in part the resulting IEEE Standards publication. The contributor also acknowledges and accepts that this contribution may be made public by IEEE 802.16.
Patent Policy	The contributor is familiar with the IEEE-SA Patent Policy and Procedures: < http://standards.ieee.org/guides/bylaws/sect6-7.html#6 > and < http://standards.ieee.org/guides/opman/sect6.html#6.3 >. Further information is located at < http://standards.ieee.org/board/pat/pat-material.html > and < http://standards.ieee.org/board/pat >.

Proposed FDM structure between Unicast and E-MBS and E-MBS Channel Structure for 802.16m

*Shigeo Terabe, Tsuguhide Aoki, Saori Fukushi
Toshiba corporation*

*Yong Sun
Toshiba Research Europe Limited*

1. Introduction

In the current SDD text, FDM is supported for both MBS and unicast within LRU level. The advantages are as follows:

- Improves flexibility of unicast resource scheduling.
- Realtime unicast packets such as re-transmission or UL ack/nck remain unaffected.
- Improve MBS throughput by applying unused unicast transmit power to MBS.

To take full advantage of FDM, the following requirements have to be met on physical resource mapping:

1. Localized unicast might be flexibly scheduled.
2. Keep the sufficient frequency diversity gain for MBS and distributed unicast.

As for 1., it is important that localized unicast should be scheduled to any physical resource in whole system bandwidth

As for 2., the physical resource of both MBS and distributed unicast have to be scheduled in distributed manner in whole system bandwidth. In addition, regarding to MBS boosting, MBS resource may never be scheduled continuously over the wide bandwidth from the regulation's point of view.

In this contribution, the possible alternative options for FDM structure between localized/distributed unicast and MBS are lined up. And then, most preferable FDM structure is discussed on throughput for both localized/distributed Unicast and MBS.

Meanwhile, two alternative schemes are proposed for MBS channel structure as below:

- Common pilot and common data among cells
- Common phase difference between pilot and data among cells with cluster-wise scrambling

The second alternative is particularly effective for FDM structure between unicast and MBS because it is possible to commonly use the unicast pilot symbol as MBS pilot. In this contribution, comparison of the above two MBS structures is performed. Hereinafter, the first proposal is referred to 'conventional method' and the second one is referred as 'cluster-wise scrambling method'.

In section 2, the basic structure and advantages of cluster-wise scrambling method are explained. In section 3, the pros and cons of different proposals for FDM structure are lined up and discussed. All the proposed schemes are quantitatively-analyzed by computer simulation in section 4 and summarizes in section 5.

2. Cluster-wise Scrambling

2.1 Basic structure

In this section, we explain cluster-wise scrambling method.

Sub-carriers on which MBS data are transmitted are split into several clusters as illustrated in Fig.1. Each cluster contains at least one pilot symbol, and each pilot symbol is scrambled with a BS-specific scrambling code. MBS data in each cluster are also scrambled with the same BS-specific code as the one used for the pilot. More precisely, pilot and MBS data in each cluster are rotated by the same amount as that of the BS-specific scrambling code. We refer to this process as 'cluster scrambling'. Since the pilot and data in a cluster are multiplied by the same scrambling code, the received signal is equivalent to the pilot and data multiplied with the "combined" scrambling code of all surrounding BSs. Thus, the data can be equalized using the composite pilot, which is a sum of BS-specific pilots from all BSs including the effect of channel responses, without de-scrambling or separation of each BS-specific code. In other words, the scrambling process is transparent to the MS.

Regarding channel estimation of this structure, an interpolation or averaging cannot be applied across different clusters, since the "combined" scrambling code is actually unknown at the MS. In order to enhance channel estimation capability, we define the clusters as described in Fig.1. In 802.16e specification, the BS-specific scrambling code is shifted by one sub-carrier per one symbol. Therefore, by defining the pilot symbols and splitting the clusters as illustrated in Fig.1, several pilot symbols within each cluster are multiplied by the same phase rotation by the BS-specific scrambling code. This means that the "combined" scrambling code is also the same between the pilot symbols. For example, as drawn in Fig.1, three pilot symbols in each cluster are multiplied by the same BS-specific scrambling code (one of the complex values, $1+j$, $1-j$, $-1+j$ or $-1-j$).

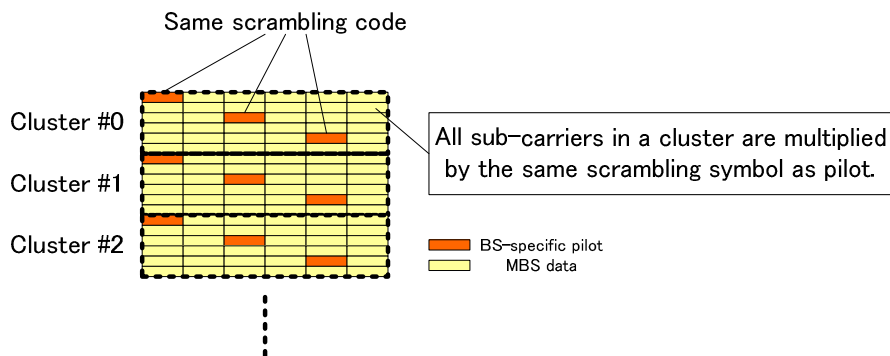

Fig.1. Basic structure of cluster-wise scrambling

2.2 Advantages

Common use of unicast pilot as MBS pilot

In conventional method, BS-common pilot symbols are necessary as MBS pilot. Since BS-specific scrambling is not applied, they cannot be used for channel estimation in unicast. Therefore, unicast RU which lies next to MBS RU, interpolation or averaging across RUs cannot be applied for channel estimation.

On the other hand, in cluster-wise scrambling method, since BS-specific pilot symbols can be used for MBS pilot, all pilot symbols improves unicast channel estimation performance regardless of the transmission type of adjacent RUs as illustrated in Fig.2. Therefore, there is no performance loss for channel estimation of unicast compared to unicast dedicated case.

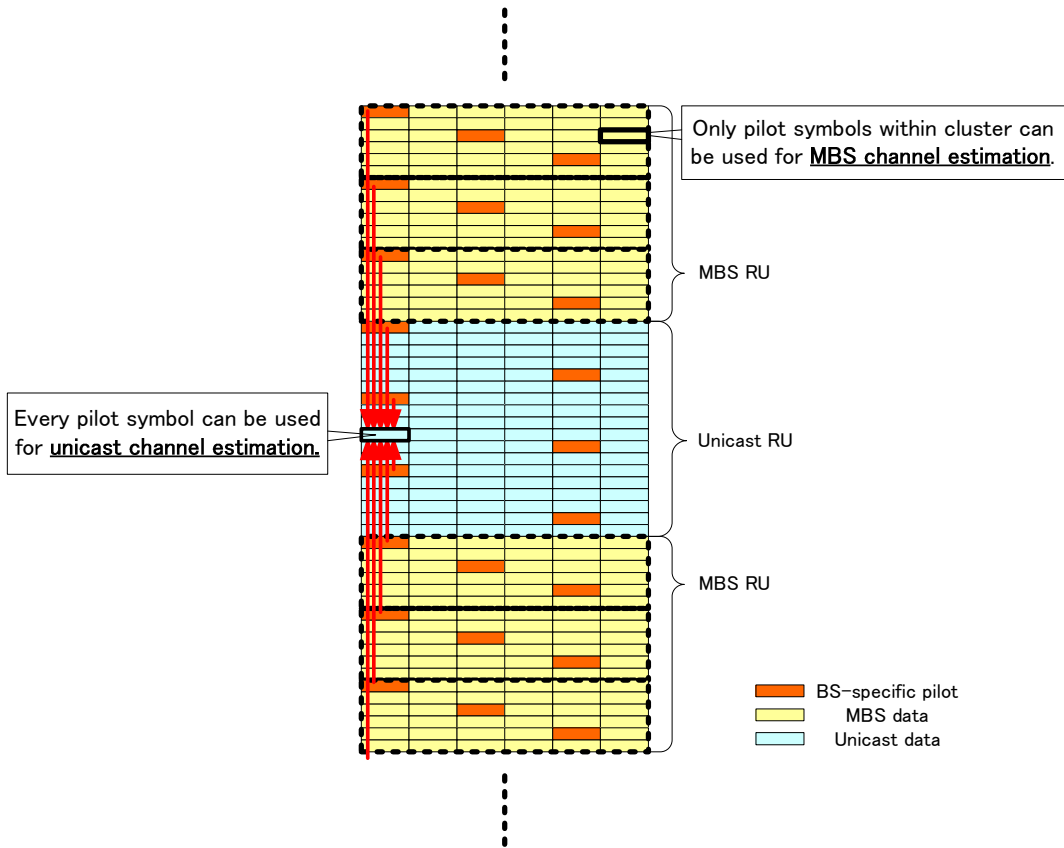

Fig.2. Channel estimation for MBS data and unicast data

Additional diversity gain

The clusters have the de-correlated channel response so that additional diversity gain is obtained as illustrated in Fig. 3.

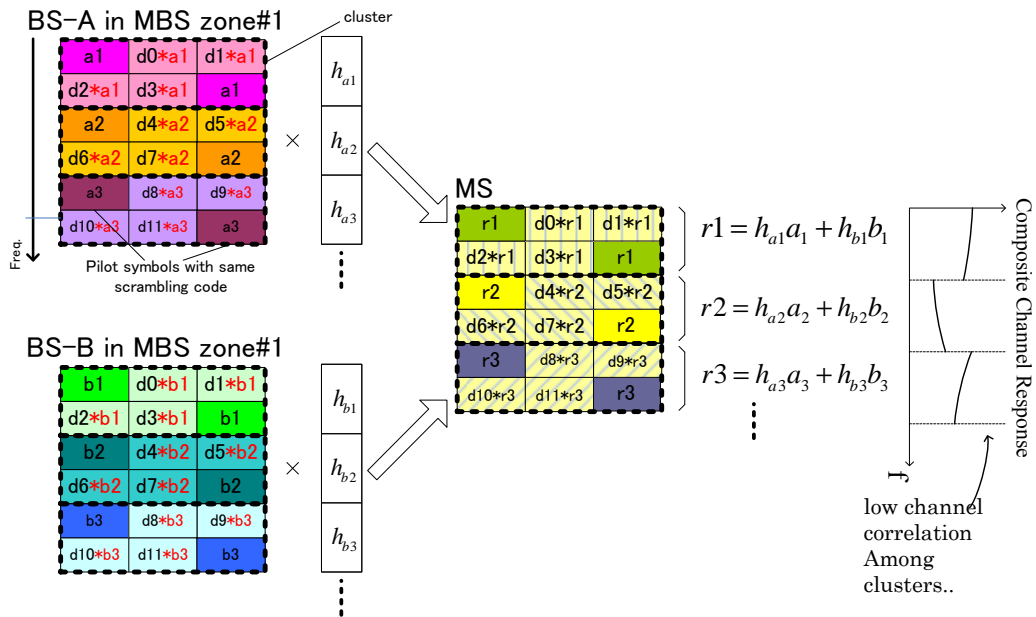

Fig.3. Mechanism to obtain an additional diversity gain

3. MBS/Unicast FDM structure

3.1 FDM structures

In this section, the possible candidates for FDM structures are lined up and each pros and cons are discussed.

Unicast RU for unicast

MBS RU for MBS

MBS/Uni RU for MBS and distributed unicast

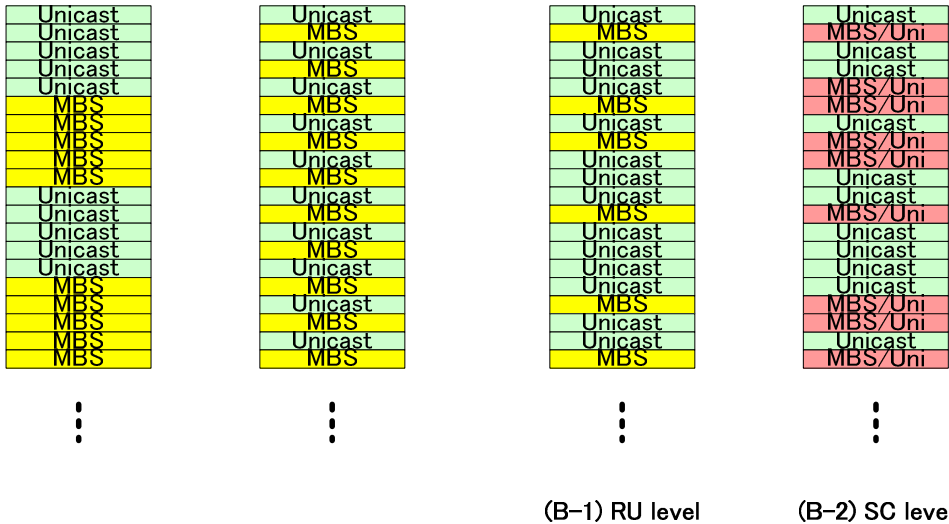

(A) Predefined partitioning

(B) High priority for Localized Unicast

Note: The ratio between Unicast and MBS resource is illustration purpose only in each figure.

Fig.4. MBS/Unicast resource partitioning

First of all, there are two possible concepts for resource allocation as illustrated in Fig.4.

- A) [Predefined partitioning] All physical resources are separated into Unicast and MBS in advance.
- B) [High priority for Localized Unicast] Localized Unicast is scheduled out of all physical resource with high priority and the scheduler shares the rest by MBS and distributed unicast.

Pros and cons of A) and B) are summarized in Table 1.

Table 1. Comparison between A) and B)

	A	B (preferred)
Unicast throughput	Worse	Fair

On unicast throughput perspective, since structure B can schedule localized unicast from a whole system bandwidth flexibly, there is no loss from the unicast dedicated case.

On the other hand, structure A has to schedule localized unicast from the predefined unicast resource only. This restriction degrades the unicast throughput. This degradation becomes high when the ratio of localized unicast is small.

The main purpose to allocate unicast resource into MBS time zone is that the unicast

transmission can continue even at MBS time zone. Therefore, since the localized unicast throughput is even significant issue, we narrow down the alternatives to structure B.

3.2 MBS structures

With regarding to FDM structure between distributed unicast and MBS, structure B is separated into two structures as illustrated in Fig.4.

- B-1) RU-level FDM between distributed unicast and MBS
- B-2) Sub-carrier level FDM between distributed unicast and MBS

In this section, we discuss the following MBS structure alternatives for the above FDM structure:

- Common pilot and common data among cells
- Common phase difference between pilot and data among cells with cluster-wise scrambling

As for structure B-1, distributed unicast and MBS can be scheduled into physical resources of both distributed unicast and MBS, the frequency diversity gain is larger than structure B-2. However, B-1 with conventional method needs both unicast pilot symbols and MBS pilot symbols, respectively, so pilot overhead becomes significant. Therefore, we remove B-1 with cluster-wise scrambling method from the alternatives.

On the other hand, cluster-wise scrambling method can use unicast pilot symbols as MBS pilot, pilot overhead issue doesn't occur.

Pros and cons of each MBS structure for B-1) and B-2) are summarized in Table 2.

Table 2) comparison between B-1 and B-2

[Conventional method]

	B-1
Freq Diversity for Dist. Uni.	Fair
Freq Diversity for MBS	Fair
CE performance for Dist. Uni.	Worse
CE performance for MBS	Fair

[Cluster-wise Scrambling method]

	B-1	B-2
Freq Diversity for Dist. Uni.	Better	Even better
Freq Diversity for MBS	Better	Even better
CE performance for Dist. Uni.	Fair	Fair
CE performance for MBS	Even worse	Even worse

Further to the above discussions, three alternatives of combination FDM structure with MBS structure are quantitatively analyzed by computer simulation in section 4.

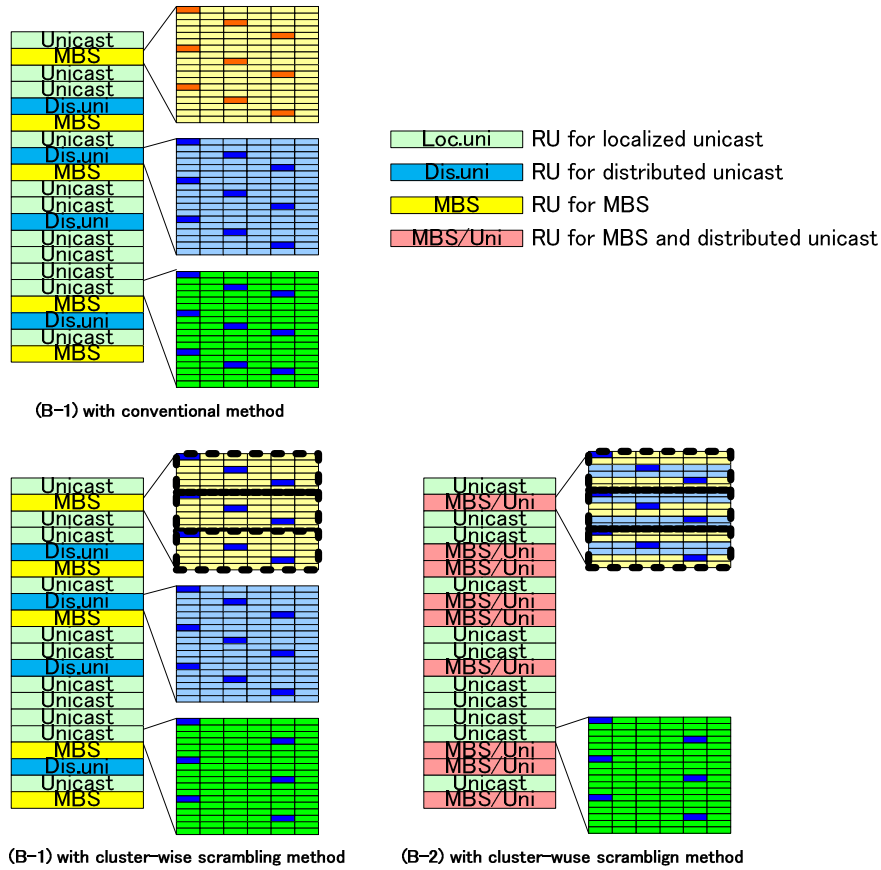

Fig.5 Three alternatives of combination FDM structure with MBS structure

4. Evaluation

We evaluate three alternatives of combination for FDM structure with MBS structure which is narrowed down in section 3 from the following perspectives:

- Frequency diversity gain for MBS
- Channel estimation performance for MBS
- Channel estimation performance for localized unicast

Simulation parameters are summarized in Table 3. The physical resource for MBS is distributedly scheduled to obtain the maximum frequency diversity gain. And the MS location is assumed at the 95% geometry point as illustrated in Fig.6 where the delay spread is largest and conventional method can earn the maximum frequency diversity gain.

Table 3. Simulation parameter

Inter-site distance	500m
System bandwidth	5MHz
Number of MBS symbols	6 OFDM symbol
Data modulation	16QAM
Channel coding	Turbo code (K=4, R=1/2) Max-Log-Map (8 iteration)
Path model	Pedestrian B
UE speed	3km/h(fD=5.55Hz), 120km/h(fD=222Hz)
Channel estimation	Ideal, MMSE

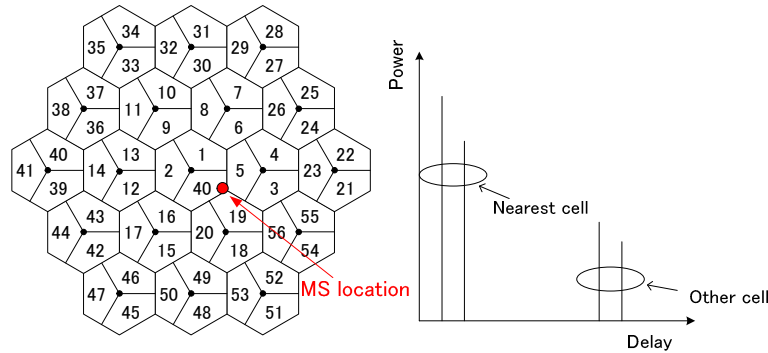

Fig.6. MS location

Frequency diversity gain for MBS

Fig.7 shows the frequency diversity gain on the ratio of MBS to distributed unicast and MBS. We assumed that the all unicast is 'distributed unicast' and channel estimation is perfect.

From the simulation result, when the MBS ratio is small (e.g. at 10%), two methods of B-1 structure lose their frequency diversity gain significantly. However, B-2 with cluster-wise scrambling still remain frequency diversity gain and is better than others in approximately 3dB. When the MBS ratio becomes larger (e.g., >50%), both B-1 and B-2 with cluster-wise scrambling method overperforms conventional method in approximately 1.5dB. This gain comes from the additional diversity gain of the cluster-wise scrambling method which has been explained in section 2.2.

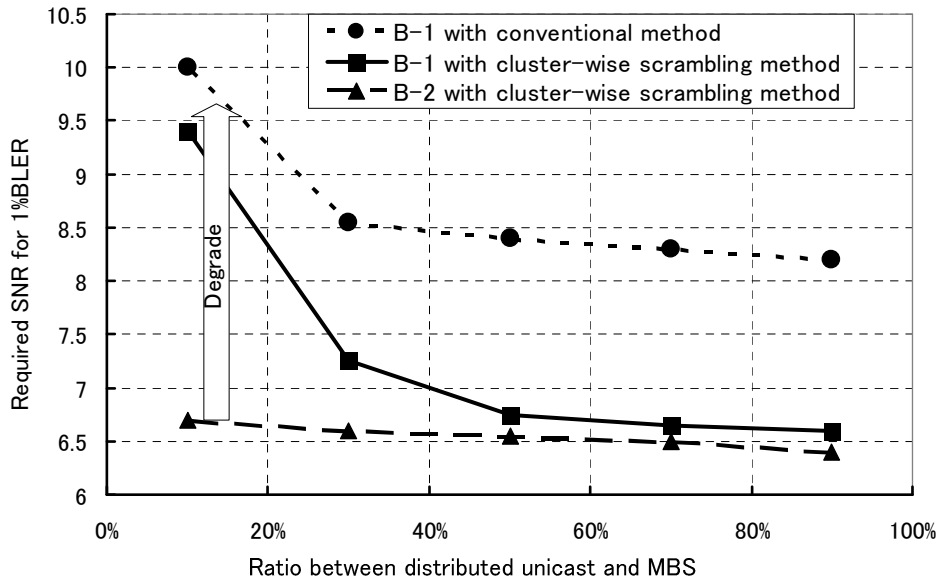

Fig.7 Ratio of MBS to distributed unicast v.s. required SNR for 1%BLER

Channel estimation performance for MBS

From the view point of channel estimation performance for MBS, the performance loss of cluster-wise scrambling method is larger than conventional method in 0.4dB as shown in Fig.8. However, with the channel estimation degradation considered, the cluster-wise scrambling method is preferable to conventional method.

We assumed 50% ratio of MBS to dedicated unicast. And we simulated two pilot overhead case, 8.3% and 5.5% respectively. In 5.5% case, each method degrades their performance with channel estimation about 0.5dB due to the lack of pilot energy.

The optimal pilot overhead of MBS channel is FFS.

Pilot overhead = 8.3%

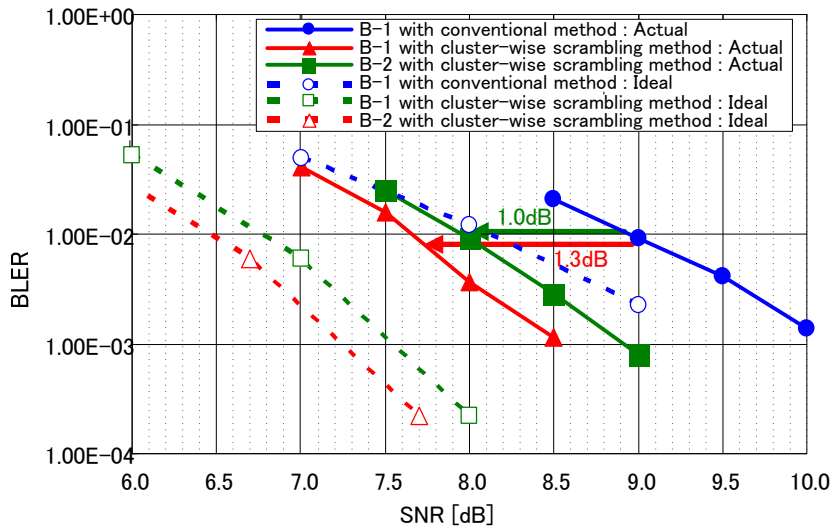

Pilot overhead = 5.5%

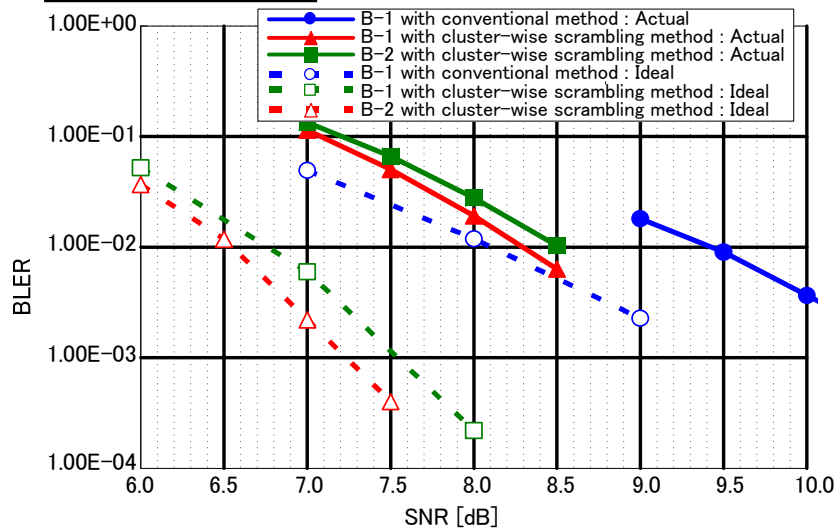

Fig.8 Channel estimation performance for MBS

Channel estimation performance for unicast

Fig.9 shows the channel estimation performance between pilot symbols in single RU case (means unicast with conventional method) and all RUs case (means unicast with cluster-wise scrambling method). 5.5% pilot overhead is assumed. Simulation result shows that there is approximately 0.7dB and 0.3dB gain from cluster-wise scrambling method to conventional method in unicast channel estimation performance.

This is additional advantage of cluster-wise scrambling method.

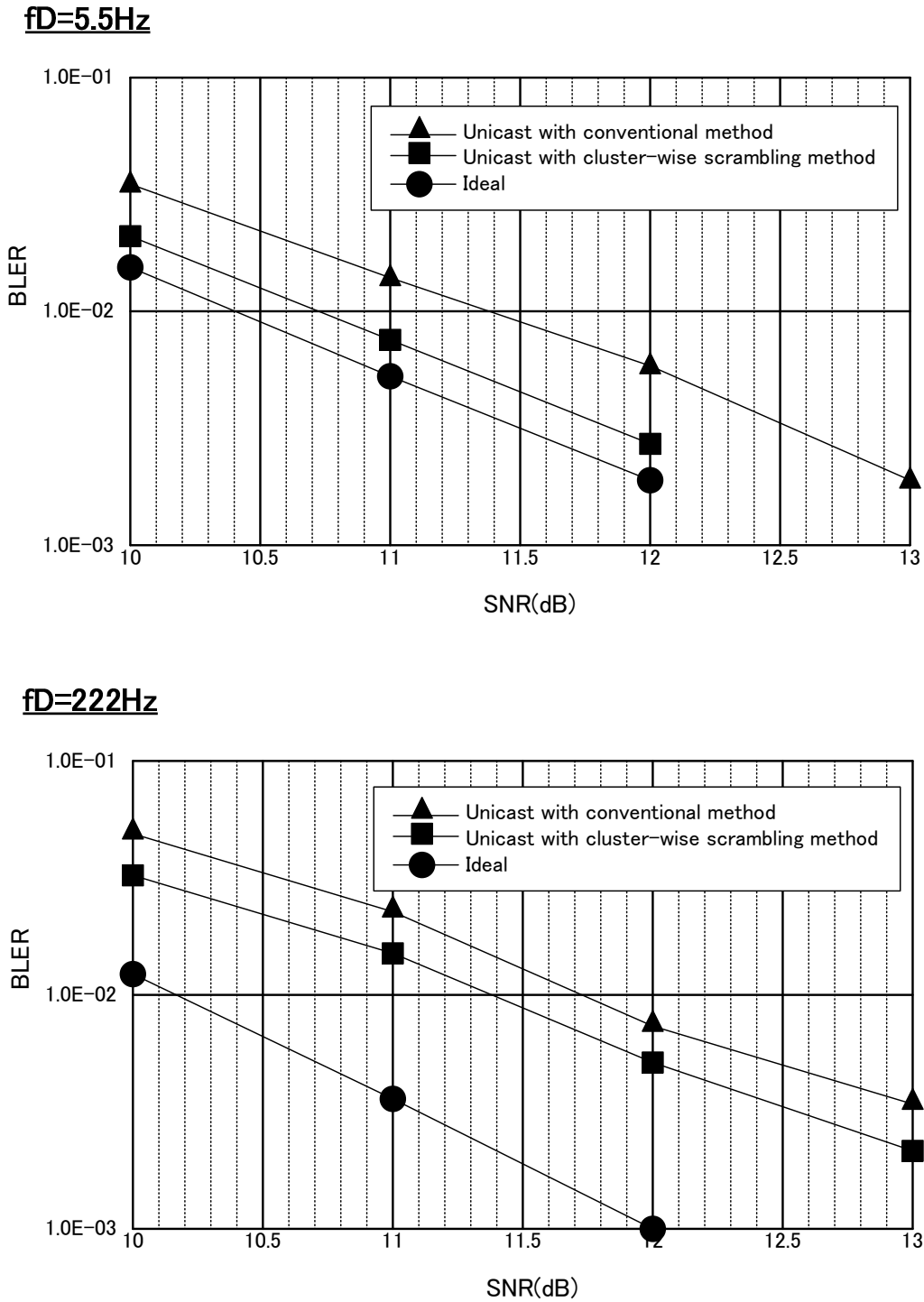

Fig.9 Channel estimation performance for localized unicast

4. Summary

In this contribution, we lined up the possible alternatives for FDM structure between localized unicast and distributed unicast/MBS. And we weighed up the pros and cons and evaluated from the reception performance perspective.

Our conclusions are as follows;

- From the view point of performance for localized unicast, it is desired that the localized unicast is scheduled first and the rest of physical resources is shared by distributed unicast and MBS.
- From the view point of performance for distributed unicast and MBS, it is desired that the distributed unicast and MBS is FDMed at sub-carrier level and the cluster-wise scrambling is applied as MBS structure.

Proposed Text

The following text is proposed to be captured in the IEEE 802.16m system description document (SDD).

----- Start of the proposed text -----

[Insert the following text into this section]

11.5.1.1 Distributed resource unit

The distributed resource unit (DRU) can be used to achieve frequency diversity gain. The DRU contains a group of subcarriers which are spread across the distributed group within a frequency partition by the subcarrier permutation. The size of the DRU equals the size of PRU, i.e., P_{sc} subcarriers by N_{sym} OFDMA symbols. The minimum unit for forming the DRU is equal to one subcarrier. **The DRU can be allocated in E-MBS subframe.**

11.5.1.2 Localized/Contiguous resource unit

The localized resource unit, a.k.a. contiguous resource unit (CRU) can be used to achieve frequency-selective scheduling gain. The CRU contains a group of subcarriers which are contiguous across the localized group within a frequency partition. The size of the CRU equals the size of the PRU, i.e., P_{sc} subcarriers by N_{sym} OFDMA symbols. **The CRU can be allocated in E-MBS subframe.**

11.5.3.1 E-MBS ~~zone specific pilot for MBSFN~~

~~E-MBS zone specific pilot shall only be transmitted for MBSFN transmissions.~~

~~BS specific pilot which is the same pilot as unicast transmission shall be used as E-MBS pilot and the phase difference between BS specific pilot and E-MBS data is set to be common among E-MBS zone.~~

~~An E-MBS zone is a group of ABSs involved in an SFN transmission. The E-MBS zone specific pilot, that's, common inside one E-MBS zone but different between neighboring E-MBS zones, is configured. Synchronous transmissions of the same contents with common pilot from multiple ABS in one MBS zone would result in correct MBSFN channel estimation.~~

The E-MBS zone specific pilot streams depends on the maximum number of streams

within the E-MBS zone. Pilot structures/patterns should be supported up to two streams.

The definitions of the E-MBS ~~zone specific~~-pilots are FFS.

14.4.1.1 Multiplexing of Unicast Data and E-MBS Data

E-MBS service can be time domain multiplexed (TDM) with unicast service by sub-frames. ~~The MBS sub-frames are put contiguously at the end of DL sub-frames.~~

Both TDM and FDM are supported for the mixed unicast and E-MBS. E-MBS service is time domain multiplexed (TDM) with unicast service at the sub-frame level. E-MBS service is frequency domain multiplexed at the LRU level.

~~The distributed unicast and E-MBS can be frequency domain multiplexed at subcarrier level.~~

----- *End of the text* -----