

Project	IEEE 802.16 Broadband Wireless Access Working Group < http://ieee802.org/16 >	
Title	Comments on Zone Switch based Handover Procedure for IEEE P802.16m/D2 (15.2.6.4.1.2.1)	
Date Submitted	2009-11-06	
Source(s)	Yih-Guang Jan, Yang-Han Lee, Hsien-Wei Tseng, Ming-Hsueh Chuang, Jheng-Yao Lin Tamkang University (TKU)	yihjan@yahoo.com
	Youn-Tai Lee, Chun-Yen Hsu Institute for Information Industry (III)	lyt@nmi.iii.org.tw
	Shiann-Tsong Sheu National Central University (NCU)	stsheu@ce.ncu.edu.tw
	Whai-En Chen National Ilan University (NIU)	wechen@niu.edu.tw
Re:	IEEE 802.16 Working Group LB30a: P802.16m/D2	
Abstract	Comments on Zone Switch based Handover Procedure for IEEE P802.16m/D2 (15.2.6.4.1.2.1)	
Purpose	To be discussed and adopted by TGM for IEEE P802.16m/D2.	
Notice	<i>This document does not represent the agreed views of the IEEE 802.16 Working Group or any of its subgroups. It represents only the views of the participants listed in the "Source(s)" field above. It is offered as a basis for discussion. It is not binding on the contributor(s), who reserve(s) the right to add, amend or withdraw material contained herein.</i>	
Release	The contributor grants a free, irrevocable license to the IEEE to incorporate material contained in this contribution, and any modifications thereof, in the creation of an IEEE Standards publication; to copyright in the IEEE's name any IEEE Standards publication even though it may include portions of this contribution; and at the IEEE's sole discretion to permit others to reproduce in whole or in part the resulting IEEE Standards publication. The contributor also acknowledges and accepts that this contribution may be made public by IEEE 802.16.	
Patent Policy	The contributor is familiar with the IEEE-SA Patent Policy and Procedures: < http://standards.ieee.org/guides/bylaws/sect6-7.html#6 > and < http://standards.ieee.org/guides/opman/sect6.html#6.3 >. Further information is located at < http://standards.ieee.org/board/pat/pat-material.html > and < http://standards.ieee.org/board/pat >.	

Comments on Zone Switch based Handover Procedure for IEEE 802.16m/D2 (15.2.6.4.1.2.1)

Yih-Guang Jan, Yang-Han Lee, Hsien-Wei Tseng, Ming-Hsueh Chuang, Jheng-Yao Lin
Tamkang University (TKU)
Youn-Tai Lee, Chun-Yen Hsu
Institute for Information Industry (III)
Shiann-Tsong Sheu
National Central University (NCU)
Whai-En Chen
National Ilan University (NIU)

1. Introduction

This contribution provides the corrected figure in the description of Zone Switched based Handover Procedure. It has an error in the description of 'Data Path Established' in Figure 410.

2. Proposed IEEE P802.16m/D1 Text Modification

[In IEEE P80216m/D2, Section 15.2.6.4.1.2.1, replace Figure 410 by the following corrected figure]

=====*Start of Proposed Text*=====

15.2.6.4.1.2.1 Zone Switch based Handover Procedure

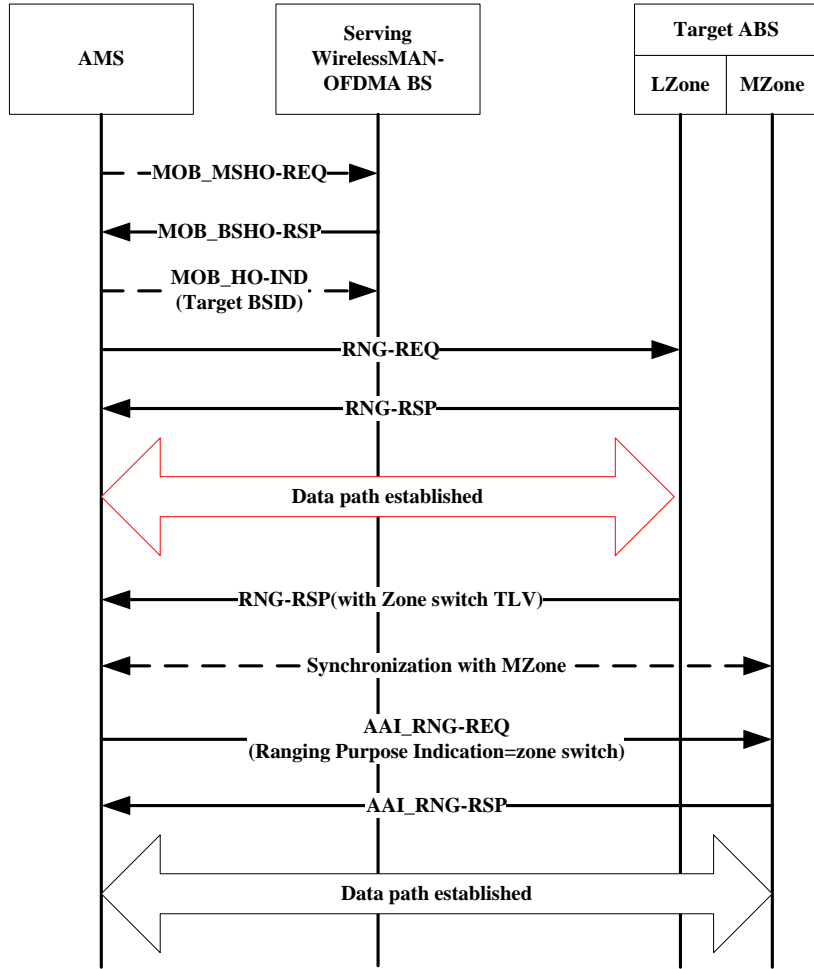

Figure 410— Handover procedure from WirelessMAN-OFDMA BS to ABS: the T-ABS instructs AMS to switch zone after completion of network reentry at LZone

-----End of Proposed Text-----