

Project	IEEE 802.16 Broadband Wireless Access Working Group < http://ieee802.org/16 >		
Title	Physical Layer Design Based on Fixed Subcarrier Spacing for Greenfield Deployment without Legacy Support		
Date Submitted	2010-04-30		
Source(s)	Sean Cai, Mary Chion, Huiying Fang, Bo Sun, Jerry Chow, Yang Liu ZTE Corporation Lei Wang InterDigital Communications	E-mail:	scai@zteusa.com Fang.huiying@zte.com.cn leiw@billeigean.com
Re:	IEEE 802.16 Working Group Letter Ballot #31 P802.16m/D4 : 16.3.2.3, 16.3.3, 16.3.5.4.1, 16.3.6.5.1.2		
Abstract	Numerology, Frame Structure, Superframe/Frame configuration and Pilot design based on fixed subcarrier spacing for Greenfield deployment without legacy support		
Purpose	To discuss and accept the proposed solution in this contribution, and adopt the solution text of this contribution into the AWD baseline document IEEE P80216m/D4.doc.		
Notice	<i>This document does not represent the agreed views of the IEEE 802.16 Working Group or any of its subgroups. It represents only the views of the participants listed in the "Source(s)" field above. It is offered as a basis for discussion. It is not binding on the contributor(s), who reserve(s) the right to add, amend or withdraw material contained herein.</i>		
Release	The contributor grants a free, irrevocable license to the IEEE to incorporate material contained in this contribution, and any modifications thereof, in the creation of an IEEE Standards publication; to copyright in the IEEE's name any IEEE Standards publication even though it may include portions of this contribution; and at the IEEE's sole discretion to permit others to reproduce in whole or in part the resulting IEEE Standards publication. The contributor also acknowledges and accepts that this contribution may be made public by IEEE 802.16.		
Patent Policy	The contributor is familiar with the IEEE-SA Patent Policy and Procedures: < http://standards.ieee.org/guides/bylaws/sect6-7.html#6 > and < http://standards.ieee.org/guides/opman/sect6.html#6.3 >. Further information is located at < http://standards.ieee.org/board/pat/pat-material.html > and < http://standards.ieee.org/board/pat >.		

Physical Layer Design Based on Fixed Subcarrier Spacing for Greenfield Deployment without Legacy Support

Sean Cai, Mary Chion, Huiying Fang, Bo Sun, Jerry Chow, Yang Liu
ZTE Corporation

Lei Wang
InterDigital Communications

Introduction

The two major competing IMT-Advanced technologies are based on LTE-Advanced and IEEE 802.16m. 3GPP is developing IMT-Advanced specification based on newly completed Long Term Evolution (LTE) standard as to be adopted as 4G standard. The air interface specification of WiMAX has been provided by IEEE 802.16 standard. The IEEE 802.16 Task Group m (TGm) is actively developing evolutionary specification based on existing IEEE 802.16 and WiMAX profile for IMT-Advanced submission. However, LTE and IEEE 802.16 have adopted different values of subcarrier spacing. LTE has fixed its subcarrier spacing to 15 KHz, but IEEE 802.16 has made its subcarrier spacing a variable for different sets of system bandwidths, namely 10.9375 KHz, 7.8125 KHz, 9.765625 KHz, and the list can go on. It is critical that the design of IEEE 802.16m can satisfy the critical needs for a cost-effective and performance competitive global technology in order to enable IEEE 802.16m to be well into the future. Meeting these needs will require some balance between how IEEE 802.16m may be constrained by the requirement to support legacy mobile stations while still providing the best solution to expand its ecosystem as a global IMT-Advanced technology. In addition, adapting a fixed subcarrier spacing scheme, will allow 16m to co-exist with other IMT-Advanced technologies.

Problem Statement

In current Amendment text, the subcarrier spacing is kept the same as in legacy systems, namely, it is a variable for different sets of system bandwidths. It is designed to allow backward compatibility to the legacy systems, however, it has the following issues:

- Different system profiles needed to support different BW, which leads to re-design of silicon for each BW set and making IOT and certification an impossible task. In addition, global roaming will be problematic if different BWs are used at different regions.
- Low spectral efficiency due to unused guard subcarriers (guard bands). This problem exists for current 802.16m design as well as 802.16e and LTE/LTE-Advanced.
- Capacity loss in multi-carrier deployment due to non-aligned subcarriers in adjacent carriers.
- Lack of multi-carrier scalability for multi-carrier deployment.
- Frame structure needs to be re-designed to support different CP ratio
- The current 16m frame design based on legacy numerology is not time aligned with LTE subframe design. This will create issues when 16m co-exist with LTE and TD-SCDMA.

Since TD-LTE and TD-SCDMA will be introduced to market earlier than 16m and 16m has to be able to adjacent channel co-exist with TD-LTE and TD-SCDMA.

LTE Type2 frame structure supports Uplink-downlink configurations with both 5 ms and 10 ms downlink-to-uplink switch-point periodicity. In case of 5 ms downlink-to-uplink switch-point periodicity, the special subframe exists in both half-frames. In case of 10 ms downlink-to-uplink switch-point periodicity, the special subframe exists in the first half-frame only. LTE Type2 Frame Uplink-downlink configuration is shown in Table x:

Table x: Uplink-downlink configurations

Uplink-downlink configuration	Downlink-to-Uplink Switch-point periodicity	Subframe number									
		0	1	2	3	4	5	6	7	8	9
0	5 ms	D	S	U	U	U	D	S	U	U	U
1	5 ms	D	S	U	U	D	D	S	U	U	D
2	5 ms	D	S	U	D	D	D	S	U	D	D
3	10 ms	D	S	U	U	U	D	D	D	D	D
4	10 ms	D	S	U	U	D	D	D	D	D	D
5	10 ms	D	S	U	D	D	D	D	D	D	D
6	5 ms	D	S	U	U	U	D	S	U	U	D

In order to meet the time alignment requirement, some symbols of 16m system will be punctured to meet the co-exist requirement. Fig 1 is an example shown in 16m SDD to minimize the number of punctured symbols by configurable delay or offset between the beginning of an IEEE 802.16m frame and an LTE-TDD frame. However, this scheme introduced in 16m can only resolve adjacent channel co-existence problem to some extent when LTE-TDD has 5ms downlink-to-uplink switch-point periodicity. When the downlink-to-uplink switch-point periodicity of LTE-TDD system is 10ms, configurable delay or offset between the beginning of an IEEE 802.16m frame and an LTE-TDD frame can not resolve the time alignment problem when 16m will be adjacent channel co-existence with LTE-TDD. As shown in Figure2, UL sub-frames of 16m Frames will be punctured in order to adjacent channel co-exist with LTE-TDD system. Since Frame configuration of each 16m Frame is the same within a superframe, 16m system can not work if adjacent channel co-existence with LTE-TDD system.

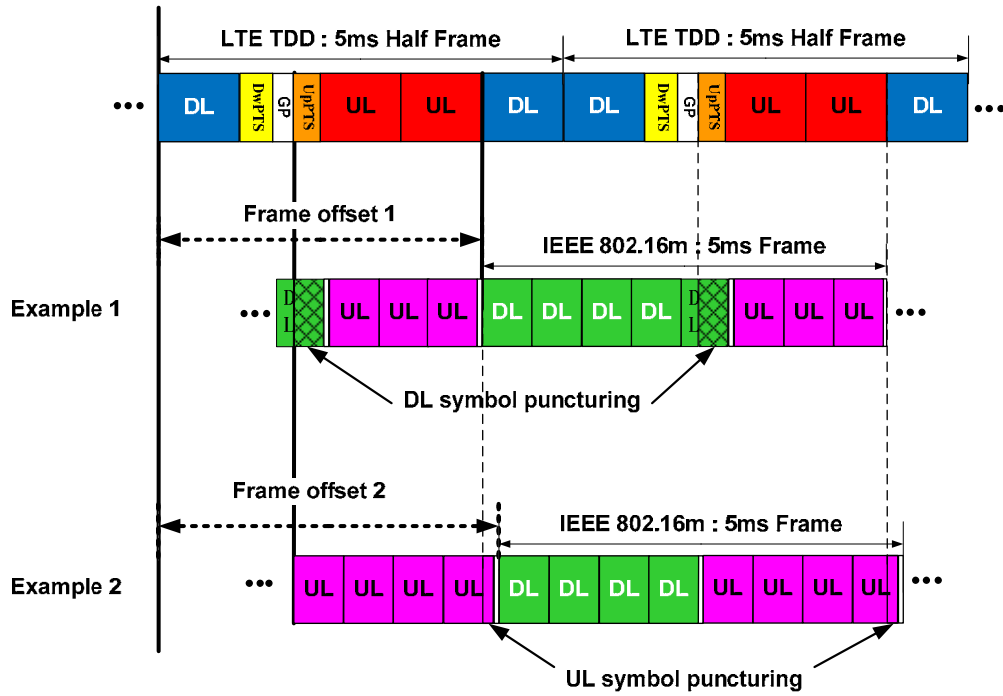

Figure 1. Alignment of IEEE 802.16m frame and LTE-TDD frame in TDD mode

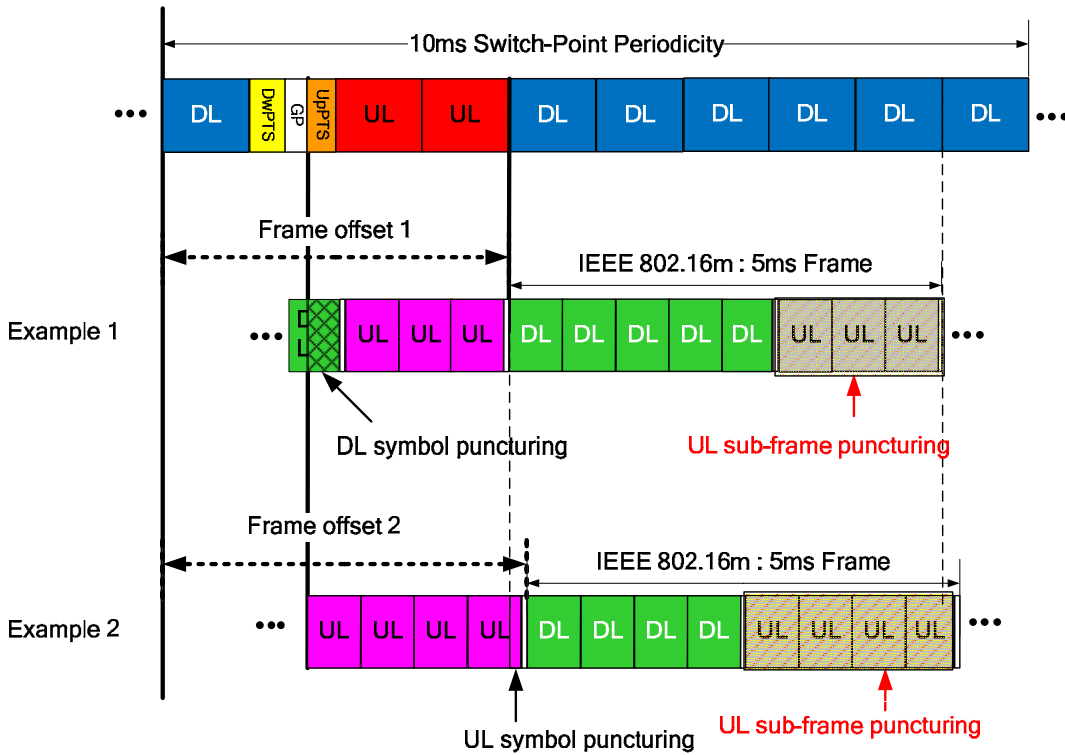

Figure 2. Alignment problem of IEEE 802.16m frame with LTE-TDD frame when 10ms switch-point periodicity

Proposed Solution

To address the issues listed in Problem Statement, this contribution proposes to a green field 16m physical layer

design based on fixed subcarrier spacing of 12.5kHz. With fixed subcarrier spacing of 12.5kHz, 16m frame structure can be designed to align with LTE-Advance frame structure using 1ms subframes. In addition, the switch points of 16m frames can be flexibly defined to co-exist with LTE-Advance system even in the same frequency band. A reduced subcarrier spacing $\Delta f_{low} = 6.25$ kHz can also be supported for low mobility and Multicast Broadcast Services dedicated cell, and an increased subcarrier spacing $\Delta f_{hi} = 25$ kHz, for extremely high mobility coverage such as to cover bullet train. Table 1 lists the common set of OFDM numerology proposed by this contribution.

The TDD and FDD channel interference issue remains a very challenging and controversial problem for today's frequency and technology agnostic band plans. The proposed solution in this contribution will be able to address this problem. Since there is no out-of-band interference between the TDD and FDD channels, the RF band filter only needs to handle the receiver desensitization issue. This is a much smaller problem comparing with the traditional out-of-band interferences between the TDD and FDD channels, especially for a receiver with a very high dynamic range. The examples of TDD and FDD coexistence are illustrated in Figure 3 and Figure 4.

Table 1. Proposed common 12.5 KHz subcarrier spacing and sampling frequency

Parameter	Unit	Parameter Values
Sub-carrier Spacing (Δf)	KHz	12.5
Sampling Frequency (F_s)	MHz	25.6
FFT size		2048

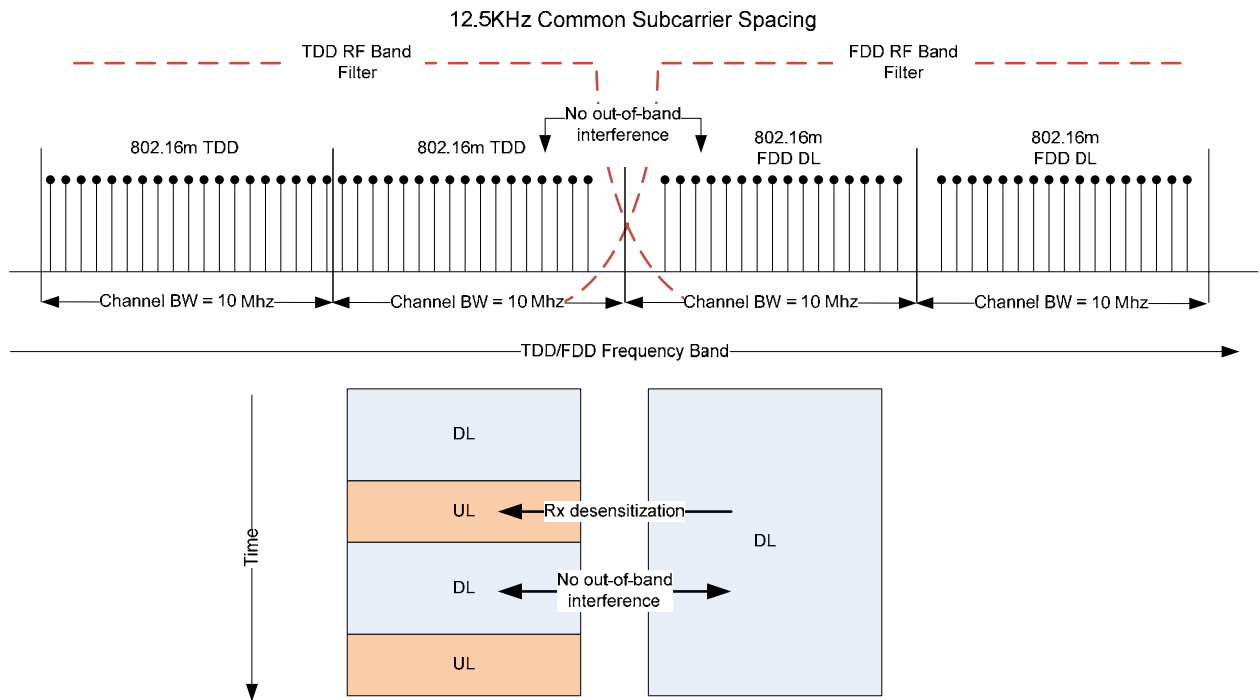

Figure 3. Example of IEEE 802.16m TDD channels coexist with IEEE 802.16m FDD downlink channels

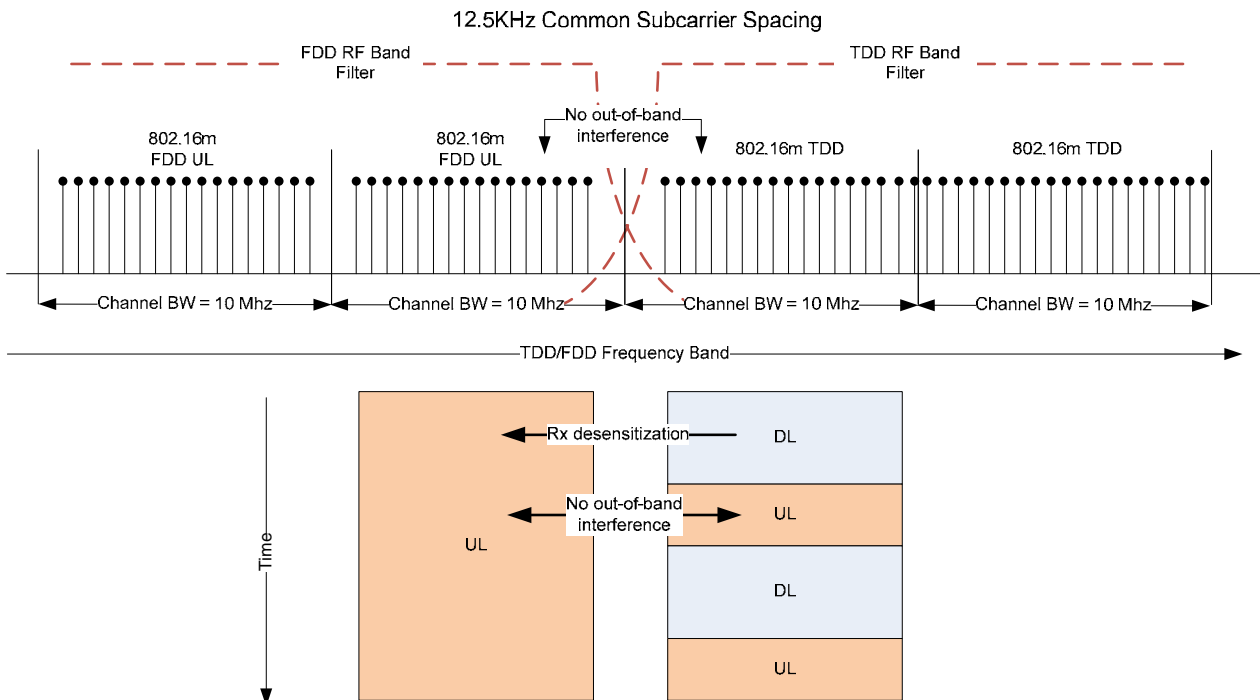

Figure 4. Example of IEEE 802.16m TDD channels coexist with IEEE 802.16m FDD uplink channels

Table 2 below provides a summary comparing how the new 12.5-kHz subcarrier spacing compares with the various options of retaining the current subcarrier spacing(s) in meeting key design considerations for 802.16m.

Table 2. Comparison of 12.5 KHz subcarrier spacing with other solutions

Key Design Considerations	Design Approach for 16m & LTE-Advanced Subcarrier Spacing		
	New 12.5 kHz	Retain Current 16e & LTE Subcarrier Spacings	
		Multiple Spacings 'As Is' (16e)	15 kHz (LTE)
<u>Greenfield (Legacy-free) Considerations</u>			
Lower Hardware Cost	√	X	√
Simplified Global Roaming	√	X	√
Maximize usable bandwidth within carrier adjacent multi-carrier scenarios	√ ⁽¹⁾	X	X ⁽²⁾
Enable efficient adjacent multicarrier operation with different bandwidths	√	X	X ⁽²⁾
Enable multicarrier overlay scenarios of different bandwidths	√	X	X
Simplified adaptation to new carrier bandwidths (e.g. 6/12 MHz)	√	X	√ ⁽³⁾
<u>Legacy Support Considerations</u>			
Legacy support via TDM multiplexing between 16e and 16m, or between LTE and LTE-Advanced	√	√	√
Legacy support via FDM multiplexing between 16e and 16m	√ ⁽⁴⁾	√ ⁽⁵⁾	N/A
16e and 16m or LTE and LTE-Advanced sharing of same freq/time area	√ ⁽⁶⁾	√ ⁽⁷⁾	√ ⁽⁸⁾
Less hardware re-design	√ ⁽⁹⁾	√ ⁽¹⁰⁾	√ ⁽¹⁰⁾
Legacy support of LTE and TD-SCDMA	√	X	√
<u>Inter-RAT Co-existence Considerations</u>			
Ease of co-existence with other IMT-Advanced Technologies (e.g. LTE) with Frame Slot Time Alignment	√	X ⁽¹¹⁾	X ⁽¹¹⁾
Reduce interference between TDD and FDD channels within the same frequency band	√	X	X

NOTES

√ indicates is able to satisfy

√- indicates is able to satisfy but with some undesirable constraints

√-- indicates is able to satisfy but not preferred due to significant drawbacks

X indicates is not feasible or not practical

- (1) Alignment of subcarrier spacing between adjacent subcarriers allow full carrier bandwidth to be utilized if adjacent carriers are 16m ... resulting in >8% improvement in available used bandwidth.
- (2) Also results in additional loss due to guard bands required between edges of adjacent carriers since carrier bandwidths are not divisible evenly by the raster. It might have been possible with a change in carrier centering from current assignments based on 200 or 250-kHz raster to new centers based on new raster (e.g. 300 kHz) that is divisible evenly by 15 kHz. However, 300 kHz will not fit any frequency bands in the world, at least it is not a generic channel raster.
- (3) Some efficiency loss since 15 kHz subcarrier spacing does not divide most of available carrier bandwidths within spectrum band/block. A channel RF filter is needed to reduce out-of-band emission. On the other hand, the new 12.5 kHz subcarrier can divide any carrier bandwidths in any spectrum band/ block in the world, and no channel RF filters are required.
- (4) Can be done with additional hardware for parallel FFTs for different subcarrier spacings, coordinated subcarrier assignment for 16m & 16e, and sufficient guard subcarriers between 16e and 16m used subcarriers. Also, same constraints as (5).
- (5) Can be done but can constrain subcarrier arrangement options on 16m subcarriers for 16e distributed subcarrier permutations (e.g. PUSC). The resource blocks are different defined in 16m and 16e, FDM is practically unworkable, not mention 7/14 or 8.75 MHz bandwidths.
- (6) 16e and 16m support via TDM multiplexing between 16e and 16m in the same RF channel.
- (7) Maximizes resource sharing between 16e and 16m but 16m MSs need to operate in a combined 16e/16m mode (tight coupling to 16e). BS has to support both 16e and 16m at the same time. With new releases of 16e and 16m in the future, it make it very challenge to design and support such BS.
- (8) No such requirements, but it can be done via TDM multiplexing.
- (9) Complexity of change depends heavily on current design ... designs for multiple subcarrier spacing/sampling freq. are well understood and not complex.
- (10) It is unclear that there won't be hardware changes/upgrades required due to other major PHY and/or MAC design changes for 16m - most likely there will be major hardware changes. The similar reason goes to LTE-Advanced. However LTE-Advanced may expect smaller changes in PHY/MAC.
- (11) Zone and subframe boundaries based on current numerology do not line up well with LTE frame element timings. Major problem expected for TDD mode. Even in FDD, a tight RF channel filter is needed to reduce out-of-band emission. Adopting the same 12.5 kHz subcarrier spacing, No RF channel filters are needed for any two systems in different bandwidths for adjacent channel co-existence.

Proposed Text

-----Start of proposed Text #1-----

[On page 414, line 6, modify the text as following]

16.3.2.3 Primitive parameters

The following four primitive parameters characterize the OFDMA symbol except when the optional PHY mode with fixed subcarrier spacing is selected. When optional PHY mode with fixed subcarrier spacing is selected, the primitive parameters are defined in subclause 16.3.2.3.1.

[Page 414, line 19, insert new subclause 15.3.2.3.1 Primitive parameters with fixed subcarrier spacing]

16.3.2.3.1 Primitive parameters with fixed subcarrier spacing

This optional PHY mode should be used for Greenfield deployment when the nominal channel bandwidth has no legacy deployment. The downlink transmission scheme is based on conventional OFDM using a cyclic prefix. The OFDM sub-carrier spacing is $\Delta f = 12.5$ kHz. In addition there are also a reduced subcarrier spacing $\Delta f_{low} = 6.25$ kHz, only for low mobility and Multicast Broadcast Services dedicated cell, and an increased subcarrier spacing $\Delta f_{hi} = 25$ kHz, for extremely high mobility coverage such as to cover bullet train.

Table aaa Basic OFDM numerology

Parameter	Unit	Parameter Values
Sub-carrier Spacing (Δf)	KHz	12.5
Optional sub-carrier Spacing (Δf_{low} , Δf_{hi})	KHz	6.25, 25
Sampling Frequency (F_s)	MHz	25.6
Sampling Period (T_s)	μs	0.0390625
Number of T_s for 10ms	T_s	256000
FFT size		2048

[Page 414, line23, modify text as following]

16.3.2.4 Derived parameters

The following parameters are defined in terms of the primitive parameters of 15.3.2.3 except when the optional PHY mode with fixed subcarrier spacing is selected. When optional PHY mode with fixed subcarrier spacing is selected, the primitive parameters are defined in subclause 16.3.2.4.1

[Page 414, line 44, insert new subclause 16.3.2.4.1 Derived parameters for fixed subcarrier spacing]

16.3.2.4.1 Derived Parameters for fixed subcarrier spacing

In the case of 12.5 kHz sub-carrier spacing there are 4 cyclic-prefix (CP) lengths. These are CP choices for a 1-ms subframe, corresponding to 12, 10, 11, and 9 OFDM symbols per subframe respectively.

- Normal cyclic prefix 1: $T_{CP1} = 85 \times T_s$ (OFDM symbol #0 to #11) = 3.3203125 μs , cyclic postfix = $4 \times T_s = 0.15625 \mu s$
- Extended cyclic prefix 2: $T_{CP2} = 512 \times T_s$ (OFDM symbol #0 to #9) = 20 μs
- Cyclic prefix 3: $T_{CP3} = 279 \times T_s$ (OFDM symbol #0 to #10) = 10.8984375 μs , cyclic postfix = $3 \times T_s = 0.1171875 \mu s$
- Cyclic prefix 4: $T_{CP4} = 796 \times T_s$ (OFDM symbol #0 to #8) = 31.09375 μs , cyclic postfix = $4 \times T_s = 0.15625 \mu s$

where $T_s = 1 / (2048 \times \Delta f)$ Normal cyclic prefix 1

In the case of 6.25 kHz sub-carrier spacing there are 2 cyclic-prefix (CP) lengths. These are CP choices for a 1-ms subframe, corresponding to 6, and 5 OFDM symbols per subframe respectively.

- Low Δf cyclic prefix 1: $T_{CP-low1} = 170 \times T_s$ (OFDM symbol #0 to #5) = 6.640625 μs , cyclic postfix = $4 \times T_s = 0.15625 \mu s$
- Low Δf cyclic prefix 2: $T_{CP-low1} = 1024 \times T_s$ (OFDM symbol #0 to #4) = 40 μs

In the case of 25 kHz sub-carrier spacing there are 2 cyclic-prefix (CP) lengths. These are CP choices for a 1-ms subframe, corresponding to 21, and 15 OFDM symbols per subframe respectively.

- High Δf cyclic prefix 1: $T_{CP-hi1} = 195 \times T_s$ (OFDM symbol #0 to #20) = 7.6171875 μs , cyclic postfix = $1 \times T_s = 0.0390625 \mu s$
- High Δf cyclic prefix 2: $T_{CP-hi2} = 682 \times T_s$ (OFDM symbol #0 to #14) = 26.640625 μs , cyclic postfix = $10 \times T_s = 0.390625 \mu s$
- High Δf cyclic prefix 3: $T_{CP-hi3} = 89 \times T_s$ (OFDM symbol #0 to #22) = 3.4765625 μs , cyclic postfix = $1 \times T_s = 0.0390625 \mu s$
- High Δf cyclic prefix 4: $T_{CP-hi4} = 398 \times T_s$ (OFDM symbol #0 to #17) = 15.546875 μs , cyclic postfix = $4 \times T_s = 0.15625 \mu s$

Table 803 OFDMA parameters for fixed Greenfield profile

<u>Sub-carrier Spacing</u>					
<u>($\Delta f, \Delta f_{low}, \Delta f_{hi}$)</u>		<u>KHz</u>	<u>12.5</u>	<u>6.25</u>	<u>25</u>
<u>Subframe Duration</u>		<u>ms</u>	<u>1</u>	<u>1</u>	<u>1</u>
<u>Number of T_s</u>		<u>ms</u>	<u>25600</u>	<u>25600</u>	<u>25600</u>
<u>CP Length</u> <u>(T_{CP})</u>	<u>Normal CP1</u>	<u>T_s</u>	<u>85</u>	<u>170</u>	<u>195</u>
	<u>Extended CP2</u>	<u>T_s</u>	<u>512</u>	<u>1024</u>	<u>682</u>
	<u>CP3</u>	<u>T_s</u>	<u>279</u>	<u>-</u>	<u>89</u>
	<u>CP4</u>	<u>T_s</u>	<u>796</u>	<u>-</u>	<u>398</u>
<u>Number of OFDM Symbols Per Subframe</u>		<u>N_{CP1}</u>	<u>12</u>	<u>6</u>	<u>21</u>
		<u>N_{CP2}</u>	<u>10</u>	<u>5</u>	<u>15</u>
		<u>N_{CP3}</u>	<u>11</u>	<u>-</u>	<u>23</u>
		<u>N_{CP4}</u>	<u>9</u>	<u>-</u>	<u>18</u>
<u>Extra Samples for Subframe Idle Time</u>	<u>n_{CP1}</u>	<u>T_s</u>	<u>4</u>	<u>4</u>	<u>1</u>
	<u>n_{CP2}</u>		<u>0</u>	<u>0</u>	<u>10</u>
	<u>n_{CP3}</u>		<u>3</u>	<u>-</u>	<u>1</u>
	<u>n_{CP4}</u>		<u>4</u>	<u>-</u>	<u>4</u>

All frequency bandwidths are supported. The following table provides the example of the existing frequency band plans.

Table 804 Example of supported Greenfield system bandwidths

Parameter		Unit	Parameter Values							
Channel Bandwidth (BW)		MHz	1.4	2.5	3	3.5	5	6	7	8
Number of Used sub-carriers (Nused)	$N_{sc}^{RB} = 16$		112	192	240	272	400	480	560	640

Parameter		Unit	Parameter Values (Continue)							
Channel Bandwidth (BW)		MHz	8.75	10	11	12	14	15	20	40
Number of Used sub-carriers (Nused)	$N_{sc}^{RB} = 16$		688	800	880	960	1120	1200	1600	3200

-----End of proposed Text #1-----

-----Start of proposed Text #2-----

[On page 418, line 33, insert the following text at beginning of subclause 16.3.3.1.]

This subclause defines the basic frame structure for advance air interface except when the optional PHY mode with fixed subcarrier spacing is selected. When optional PHY mode with fixed subcarrier spacing is selected, the primitive parameters are defined in subclause 15.3.3.1.1

[On page 420, line 49, insert new subclause 16.3.3.1.1 Basic frame structure with fixed subcarrier spacing, and replace it with the following text.]

16.3.3.1.1. Basic Frame structure with fixed subcarrier spacing

The advanced air interface basic frame structure is illustrated in Figure 465a for FDD mode and Figure 465b for TDD mode. Each 20 ms superframe is divided into four equally-sized 5 ms radio frames. Each 5 ms radio frame further consists five equally-sized 1 ms subframes. According to the different configurations in Table 779a, the number of symbols in a subframe can be different.

In the case of 12.5 kHz sub-carrier spacing there are 4 cyclic-prefix (CP) lengths. These are CP choices for a 1-ms subframe, corresponding to 12, 10, 11, and 9 OFDM symbols per subframe respectively.

- Normal cyclic prefix 1: $T_{CP1} = 85 \times T_s$ (OFDM symbol #0 to #11) = 3.3203125 μ s, cyclic postfix = $4 \times T_s = 0.15625 \mu$ s
- Extended cyclic prefix 2: $T_{CP2} = 512 \times T_s$ (OFDM symbol #0 to #9) = 20 μ s
- Cyclic prefix 3: $T_{CP3} = 279 \times T_s$ (OFDM symbol #0 to #10) = 10.8984375 μ s, cyclic postfix = $3 \times T_s = 0.1171875 \mu$ s
- Cyclic prefix 4: $T_{CP4} = 796 \times T_s$ (OFDM symbol #0 to #8) = 31.09375 μ s, cyclic postfix = $4 \times T_s = 0.15625 \mu$ s

where $T_s = 1 / (2048 \times \Delta f)$

In the case of 6.25 kHz sub-carrier spacing there are 2 cyclic-prefix (CP) lengths. These are CP choices for a 1-ms subframe, corresponding to 6, and 5 OFDM symbols per subframe respectively.

- Low Δf cyclic prefix 1: $T_{CP-low1} = 170 \times T_s$ (OFDM symbol #0 to #5) = 6.640625 μ s, cyclic postfix = $4 \times T_s = 0.15625 \mu$ s
- Low Δf cyclic prefix 2: $T_{CP-low1} = 1024 \times T_s$ (OFDM symbol #0 to #4) = 40 μ s

In the case of 25 kHz sub-carrier spacing there are 2 cyclic-prefix (CP) lengths. These are CP choices for a 1-ms subframe, corresponding to 21, and 15 OFDM symbols per subframe respectively.

- High Δf cyclic prefix 1: $T_{CP-hi1} = 195 \times T_s$ (OFDM symbol #0 to #20) = 7.6171875 μ s, cyclic postfix = $1 \times T_s = 0.0390625 \mu$ s
- High Δf cyclic prefix 2: $T_{CP-hi2} = 682 \times T_s$ (OFDM symbol #0 to #14) = 26.640625 μ s, cyclic postfix = $10 \times T_s = 0.390625 \mu$ s
- High Δf cyclic prefix 3: $T_{CP-hi3} = 89 \times T_s$ (OFDM symbol #0 to #22) = 3.4765625 μ s, cyclic postfix = $1 \times T_s = 0.0390625 \mu$ s
- High Δf cyclic prefix 4: $T_{CP-hi4} = 398 \times T_s$ (OFDM symbol #0 to #17) = 15.546875 μ s, cyclic postfix = $4 \times T_s = 0.15625 \mu$ s

Table 805a Parameters of Frame Structure with fixed subcarrier spacing

<u>Sub-carrier Spacing</u>					
$(\Delta f, \Delta f_{low}, \Delta f_{hi})$		<u>KHz</u>	<u>12.5</u>	<u>6.25</u>	<u>25</u>
<u>Subframe Duration</u>		<u>ms</u>	<u>1</u>	<u>1</u>	<u>1</u>
<u>Number of Ts</u>		<u>ms</u>	<u>25600</u>	<u>25600</u>	<u>25600</u>
<u>CP Length</u> (T_{CP})	<u>Normal CP1</u>	<u>T_s</u>	<u>85</u>	<u>170</u>	<u>195</u>
	<u>Extended CP2</u>	<u>T_s</u>	<u>512</u>	<u>1024</u>	<u>682</u>
	<u>CP3</u>	<u>T_s</u>	<u>279</u>	<u>-</u>	<u>89</u>
	<u>CP4</u>	<u>T_s</u>	<u>796</u>	<u>-</u>	<u>398</u>
<u>Number of OFDM Symbols Per Subframe</u>		<u>N_{CP1}</u>	<u>12</u>	<u>6</u>	<u>21</u>
		<u>N_{CP2}</u>	<u>10</u>	<u>5</u>	<u>15</u>
		<u>N_{CP3}</u>	<u>11</u>	<u>-</u>	<u>23</u>
		<u>N_{CP4}</u>	<u>9</u>	<u>-</u>	<u>18</u>
<u>Extra Samples for Subframe Idle Time</u>	<u>n_{CP1}</u>	<u>T_s</u>	<u>4</u>	<u>4</u>	<u>1</u>
	<u>n_{CP2}</u>		<u>0</u>	<u>0</u>	<u>10</u>
	<u>n_{CP3}</u>		<u>3</u>	<u>-</u>	<u>1</u>
	<u>n_{CP4}</u>		<u>4</u>	<u>-</u>	<u>4</u>

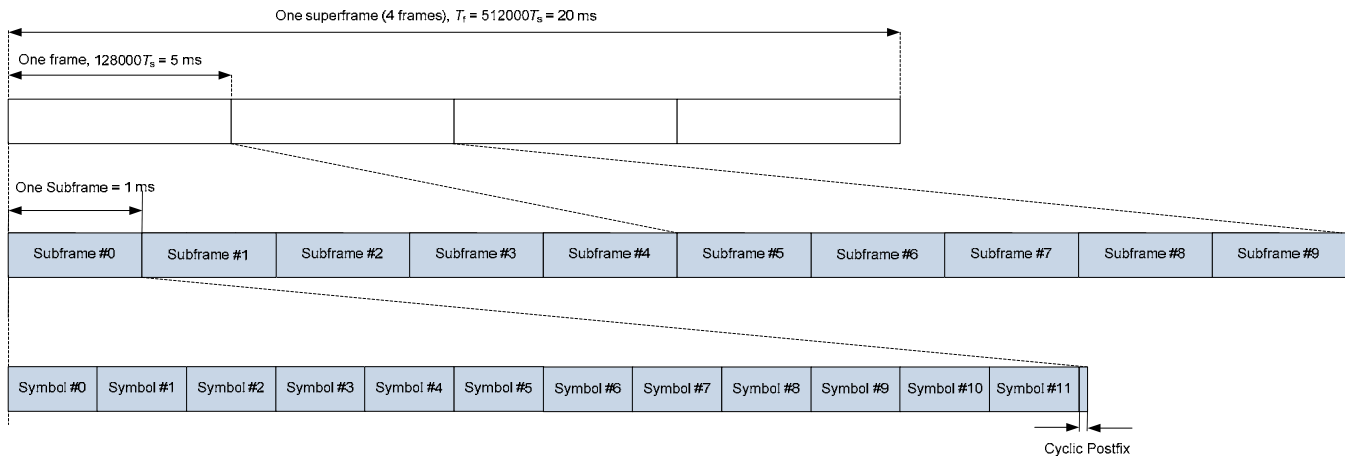

Figure 468a Basic frame structure for FDD mode

For Type TDD mode, a subframe is also the smallest unit to be configurable for downlink and uplink transmission. As shown in Figure 465a, Subframe# 0 is always reserved for downlink transmission. Starting from Subframe# 1, each subframe can be configurable for downlink or uplink transmission. For each subframe in a radio frame, “D” denotes the subframe is reserved for downlink transmission, “U” denotes the subframe is reserved for uplink transmission. The concept of slots is only used to describe the dimensions of resource blocks.

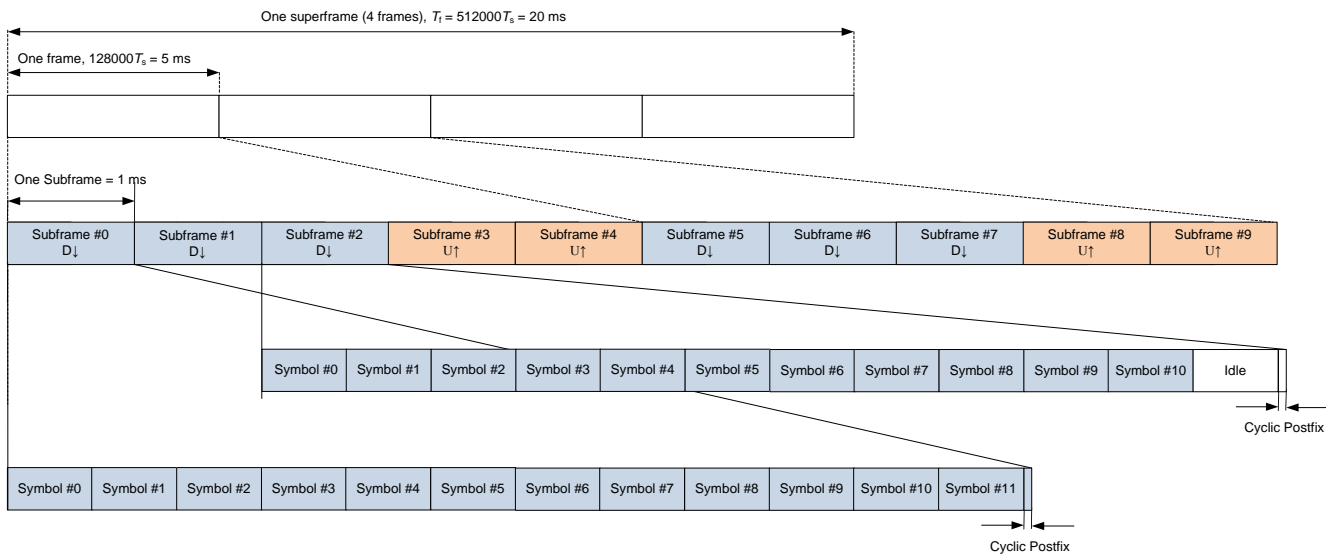

Figure 468b. Frame Structure Type for TDD mode

Downlink-uplink configurations with 5 ms, 10 ms, and 20 ms downlink-to-uplink switch-point periodicity are supported. In case of 5 ms downlink-to-uplink switch-point periodicity, the switch-point exists in each frame. In case of 10 ms downlink-to-uplink switch-point periodicity, the switch-point exists in only one of the two frames. In case of 20 ms downlink-to-uplink switch-point periodicity, the switch-point only exists in one of the four frames. Multiple switch-points are also supported within a 5-ms frame as optional features to support such as extremely high mobility performance where very fast feedbacks are required.

Table ggg shows superframe configuration, where “D” denotes the frame is reserved for downlink transmission, “U” denotes the frame is reserved for uplink transmission. “X” and “Y” denotes the frame can be configured as indicated by the Frame Configuration Index. The detail frame configurations are shown in Table hhh.

Table 805b. TDD superframe configurations index

<u>Superframe Configuration Index (SCI)</u>	<u>Frame number</u>			
	<u>0</u>	<u>1</u>	<u>2</u>	<u>3</u>
<u>0</u>	<u>X</u>	<u>Y</u>	<u>X</u>	<u>Y</u>
<u>1</u>	<u>X</u>	<u>D</u>	<u>X</u>	<u>D</u>
<u>2</u>	<u>D</u>	<u>D</u>	<u>D</u>	<u>X</u>
<u>3</u>	<u>X</u>	<u>U</u>	<u>X</u>	<u>U</u>

Table 805c. Frame structure uplink-downlink configurations index

Frame Configuration Index (FCI)	Switch-point Periodicity	Subframe number of "X (0-4),Y (5-9)" frame									
		0	1	2	3	4	5	6	7	8	9
0	5 ms	D	D	D	U	U	D	D	U	U	U
1	5 ms	D	D	D	U	U	D	D	D	U	U
2	5 ms	D	D	D	D	U	D	D	D	D	U
3	5 ms	D	D	U	U	U	D	D	U	U	U
4	>5 ms	D	D	D	D	D	D	D	D	D	D
5	<3 ms	D	D	U	D	U	D	D	U	D	U
6	<3 ms	D	D	U	D	U	D	U	U	D	U
7	2 ms	D	U	D	U	D	U	D	U	D	U
8	<3 ms	D	U	U	D	U	D	U	U	D	U
9	5 ms	D	S	U	U	U	D	S	U	U	U
10	5 ms	D	S	U	U	D	D	S	U	U	D
11	5 ms	D	S	U	D	D	D	S	U	D	D
12	10 ms	D	S	U	U	U	D	D	D	D	D
13	10 ms	D	S	U	U	D	D	D	D	D	D
14	10 ms	D	S	U	D	D	D	D	D	D	D
15	5 ms	D	S	U	U	U	D	S	U	U	D

The TDD adjacent channel coexistence with other radio access technologies, such as Long Term Evolution (LTE), can also be resolved by TDD mode with Frame Configuration Index 9 to 15, where “S” denotes the subframe is configured as the special subframe. These configurations can be used to inline the downlink-to-uplink switch-points with that of LTE TDD system. The smallest switch-point periodicity is 2 ms to allow channel fast feedback mechanism.

“S” denotes a special subframe with the three fields DwPTS, GP and UpPTS. The length of DwPTS and UpPTS is given by Table 779c subject to the total length of DwPTS, GP and UpPTS being equal to 1 ms. Subframes 0 and 5 and DwPTS are always reserved for downlink transmission. UpPTS and the subframe immediately following the special subframe are always reserved for uplink transmission. In case of FDD, operation with half duplex from UE point of view is supported.

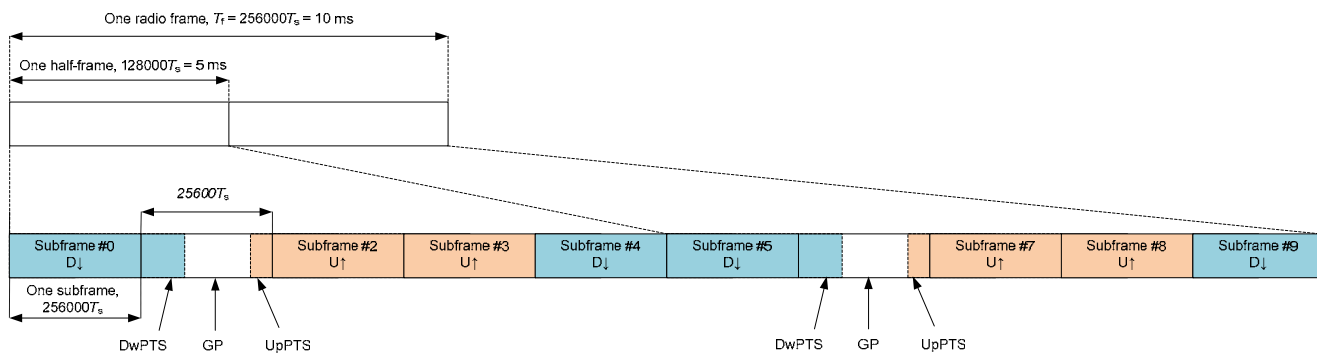

Figure 468c Frame structure with special subframe

Table 805d Configuration of special subframe “S”

Special subframe configuration	Normal cyclic prefix in downlink		Extended cyclic prefix in downlink	
	DwPTS (N_{symbol})	UpPTS (N_{symbol})	DwPTS (N_{symbol})	UpPTS (N_{symbol})
0	3	1	3	1
1	7	1	6	1
2	8	1	7	1
3	9	1	8	1
4	10	1	3	2
5	3	2	6	2
6	7	2	7	2
7	8	2		
8	9	2		

When a network is deployed, a superframe is often configured to a default system profile. However, a superframe can change its frame structure via superframe control signaling. There are many different superframe and frame configurations are available for different networks deployment. However, it is believed that only limited set of configurations are practically used within a particular network. In order to minimize the number of bits for superframe and frame configurations to be transmitted in the air by superframe header the trie data structure is used to broadcast configurations information. If the network is operating in default configuration, only one bit is transmitted in the air to indicate that the superframe and frames are configured in default mode. The example is shown in Table iii; the values of Superframe Configuration Index (SCI) and Frame Configuration Index (FCI) in the Figure 465d are selected for illustration purpose.

Table 805e. Trie data structure representation of superframe & frame configurations

<u>Bit#0 = 0</u>	<u>System Default Configuration#0:</u> <u>SCI=x0, FCI=y0</u>	-	-
<u>Bit#0 = 1</u>	<u>Bit#1 = 0, Bit#2 = 0</u>	<u>Configuration#1</u>	-
-	<u>Bit#1 = 0, Bit#2 = 1</u>	<u>Configuration#2</u>	-
-	<u>Bit#1 = 1, Bit#2 = 0</u>	<u>Configuration#3</u>	-
-	<u>Bit#1 = 1, Bit#2 = 1</u>	<u>Bit#3 = 0, Bit#4 = 0, Bit#5 = 0</u>	<u>Configuration#4:</u>
-	-	<u>Bit#3 = 0, Bit#4 = 0, Bit#5 = 1</u>	<u>Configuration#5:</u>
-	-	<u>Bit#3 = 0, Bit#4 = 1, Bit#5 = 0</u>	<u>Configuration#6:</u>
-	-	<u>Bit#3 = 0, Bit#4 = 1, Bit#5 = 1</u>	<u>Configuration#7:</u>
-	-	<u>Bit#3 = 1, Bit#4 = 0, Bit#5 = 0</u>	<u>Configuration#8:</u>
-	-	<u>Bit#3 = 1, Bit#4 = 0, Bit#5 = 1</u>	<u>Configuration#9:</u>
-	-	<u>Bit#3 = 1, Bit#4 = 1, Bit#5 = 0</u>	<u>Configuration#10:</u>
-	-	<u>Bit#3 = 1, Bit#4 = 1, Bit#5 = 1</u>	<u>Configuration#11:</u>

Note: Notations of x0 to x11 in above table are representation of Superframe Configuration Index values, and y0 to y11 are representation of Frame Configuration Index values.

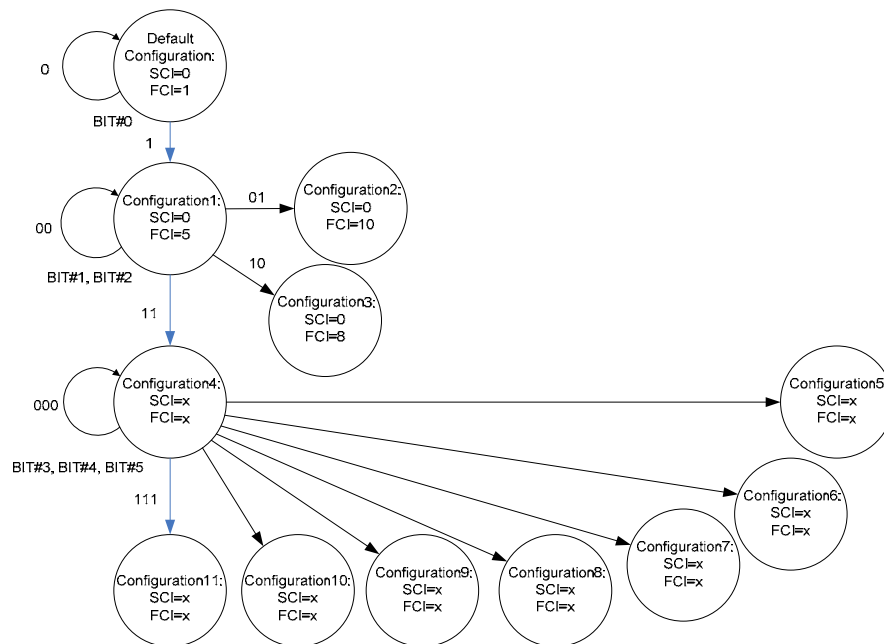

Figure 468d. Superframe & frame configurations with trie data structure

-----End of proposed Text #2-----

-----Start of proposed Text #3-----

[On page 466, line 51, modify section 16.3.5.4.1. as following]

The section specifies the pilot pattern except when the optional PHY mode with fixed subcarrier spacing is selected. When optional PHY mode with fixed subcarrier spacing is selected, the pilot patterns are defined in subclause 16.3.5.4.1.1.

[On page 475, line 45, insert section 16.3.5.4.1.1. as following]

16.3.5.4.1.1 Pilot patterns for fixed subcarrier spacing

The pilot patterns are specified within a PRU.

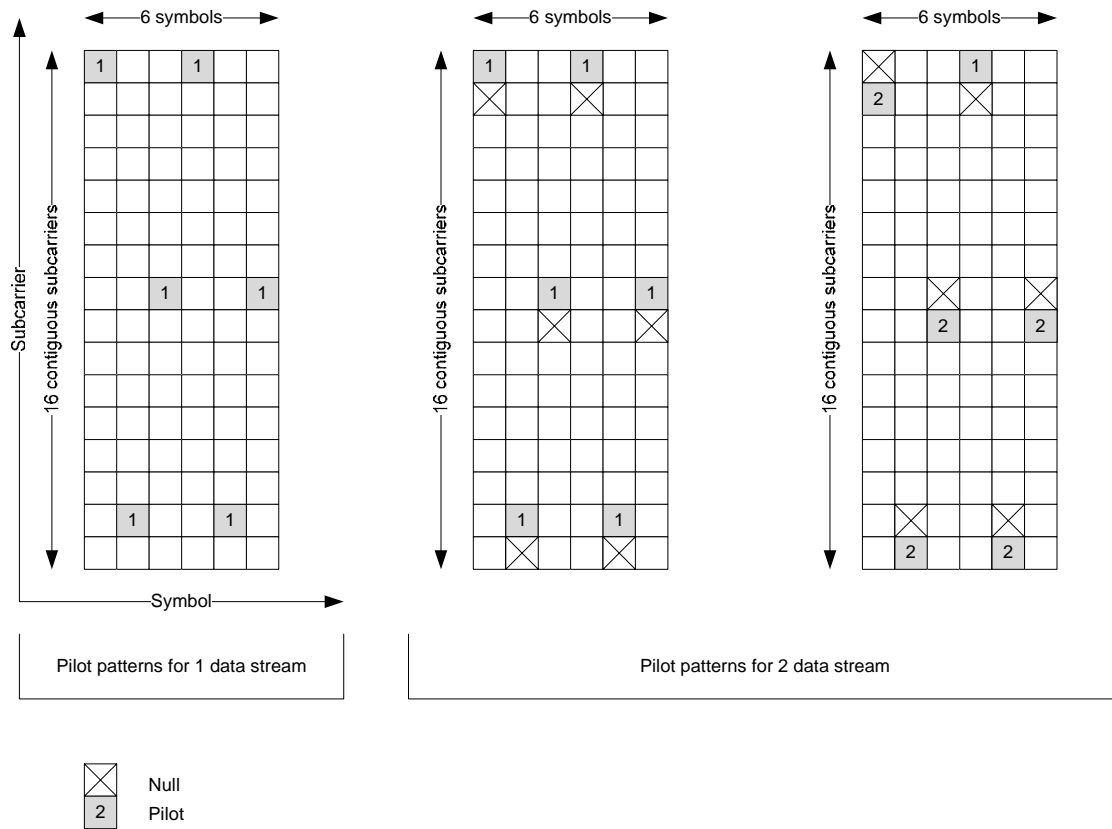

Figure 504a. Pilot patterns for 1 and 2 data streams

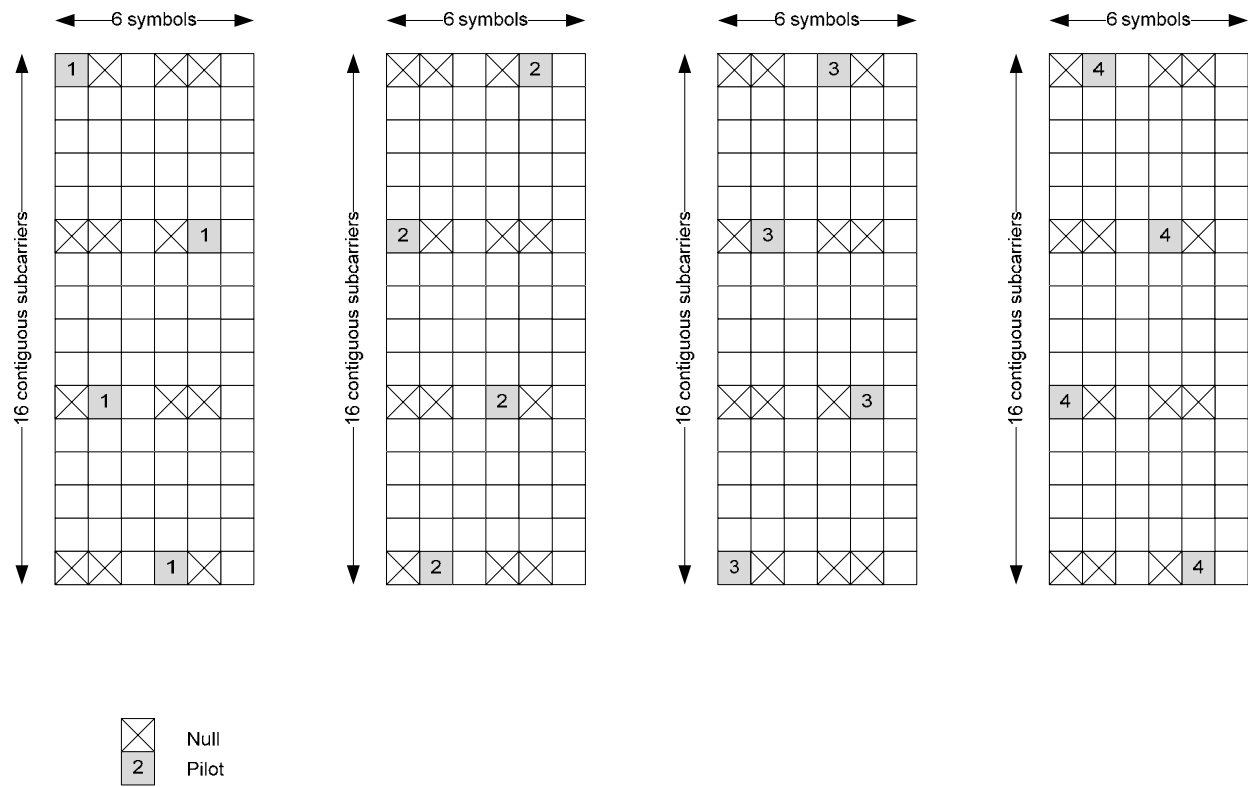

Figure 504b. Pilot patterns for 4 data streams

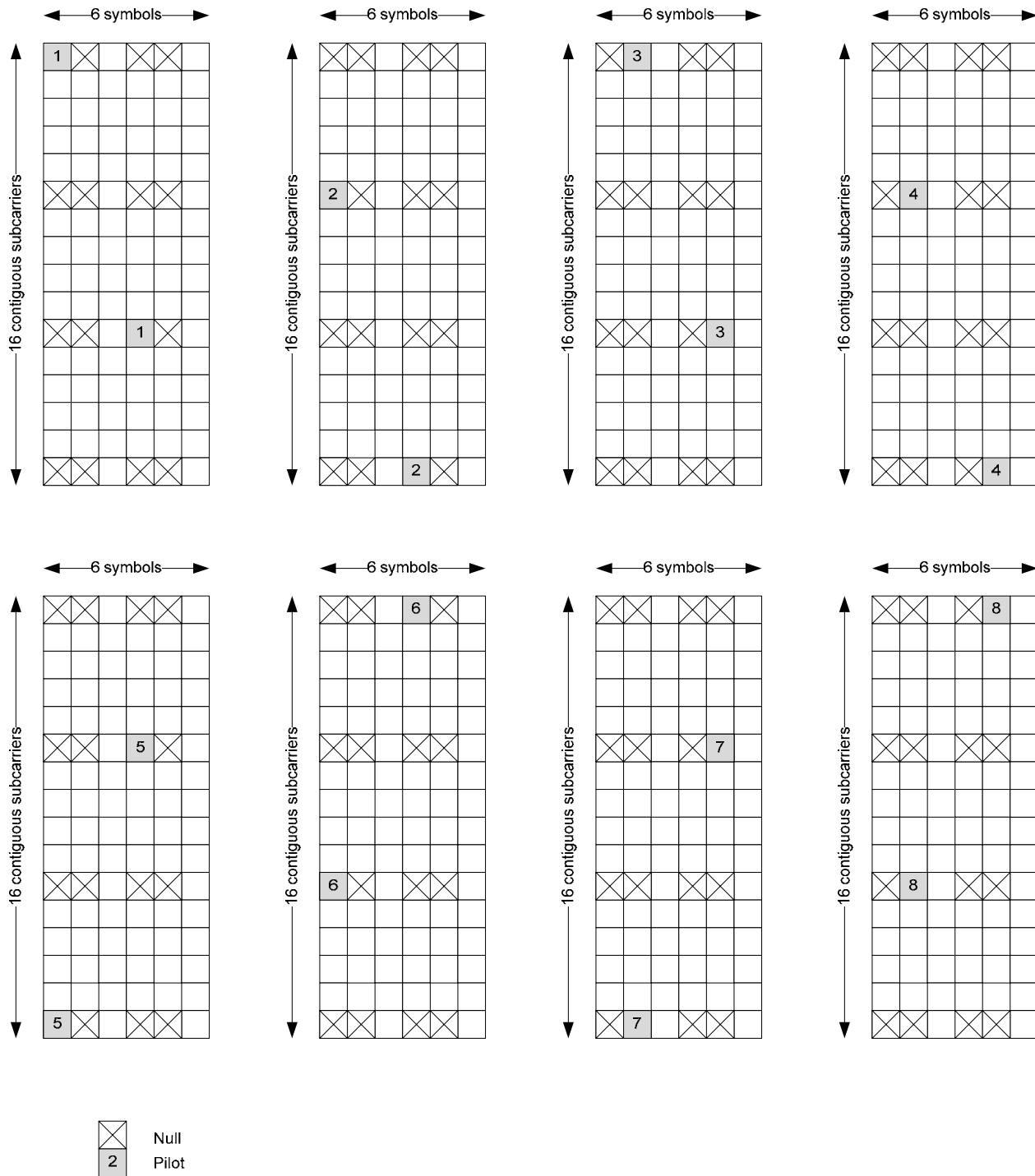

Figure 504c. Pilot patterns for 8 downlink only data streams

For $N_{\text{symb}}=5$, the last symbol of the pilot patterns as shown in Figure iii or Figure jjj is deleted. Similarly for $N_{\text{symb}}=3$, the last three symbols of the pilot patterns are deleted.

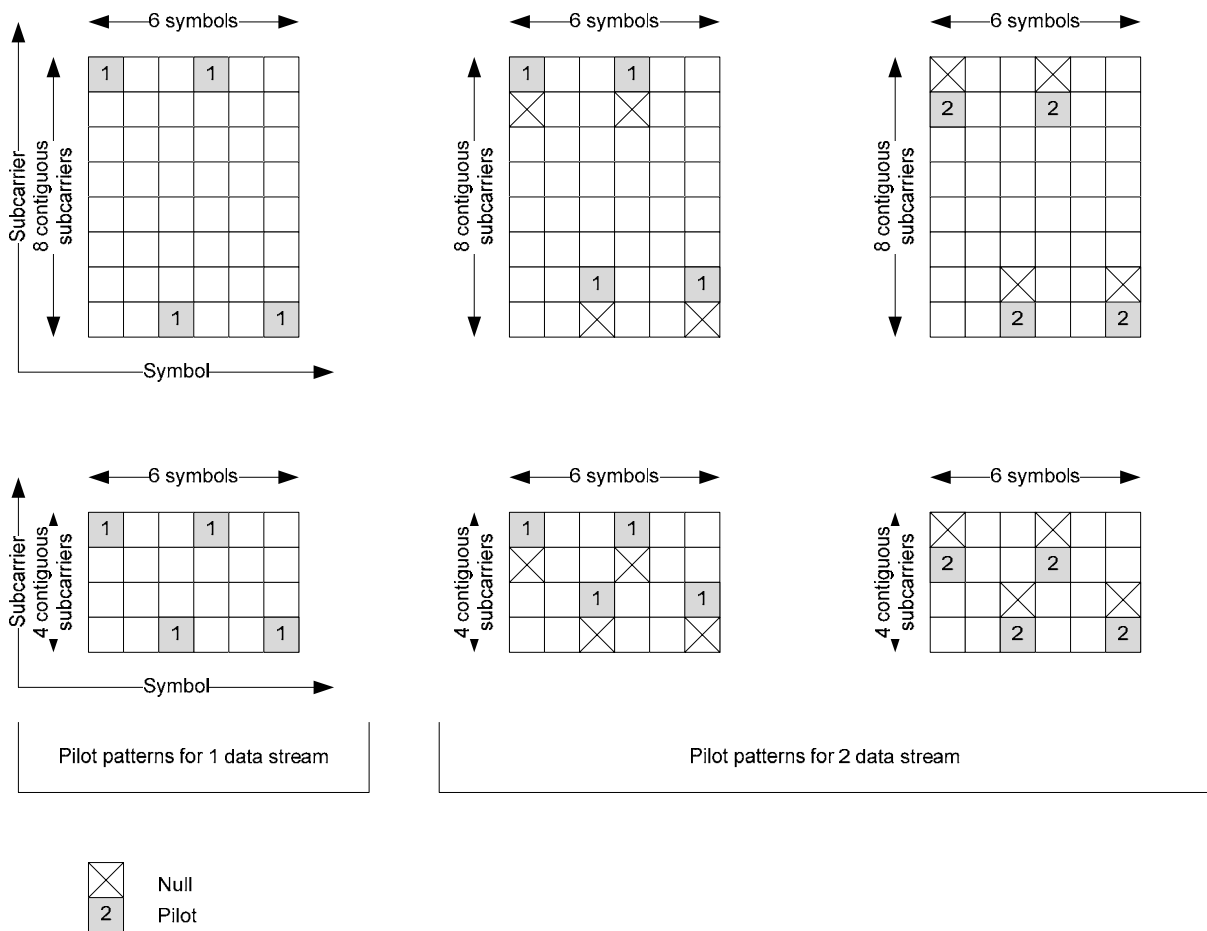

Figure 504d. Pilot patterns for LRU

For $N_{\text{symb}}=5$, the last symbol of the pilot patterns as shown in Figure kkk, or Figure lll is deleted. Similarly for $N_{\text{symb}}=3$, the last three symbols of the pilot patterns are deleted.

-----*End of proposed Text #3*-----

-----*Start of proposed Text #4*-----

[On page 528, modify Table 837. as following]

16.3.6.5.1.2 S-SFH IE

Table 837—S-SFH SP1 IE format

Syntax	Size (bit)	Notes
S-SFH SP1 IE format () {		
....		
DCASi	3/2/1	See 16.3.5.3.1 DL CRU/DRU allocation For 2048 FFT size, 3 bits For 1024 FFT size, 2 bits For 512 FFT size, 1 bit
Frame configuration index	6	The mapping between value of this index and frame configuration is listed in Table Table 780, Table 781, and Table 782. When the optional PHY mode with fixed subcarrier spacing is selected, the mapping between value of index and superframe/frame configuration is listed in Table 779e.
WirelessMAN-OFDMA support	TBD	Indicates whether frame configuration supports WirelessMAN-OFDMA systems or not 0b0 : No support of WirelessMAN-OFDMA 0b1 : Support of WirelessMAN-OFDMA

-----end of *proposed Text #4*-----

Reference

- [1] IEEE802.16m-07/002r4, IEEE802.16m system requirements
- [2] IEEE Std 802.16e-2005 and IEEE Std 802.16-2004/Cor1-2005 (Amendment and Corrigendum to IEEE Std 802.16-2004)
- [3] WiMAX Forum Mobile System Profile Release 1.0 Approved Specification
- [4] IEEE 802.16m-08/080r1, 'Proposal for IEEE 802.16m OFDMA numerology'
- [5] IEEE 802.16m-08/118r1, 'Proposed 802.16m Frame Structure Baseline Content Suitable for Use in the 802.16m SDD'

[6] IEEE 802.16m-08/236r3, 'Further Consideration on IEEE 802.16m OFDMA numerology'

[7] IEEE 802.16m-09/0010r3