



# MAN/WAN Interconnection Options for SBC

Vish Ramamurti  
George Young





# MAN/WAN interconnection

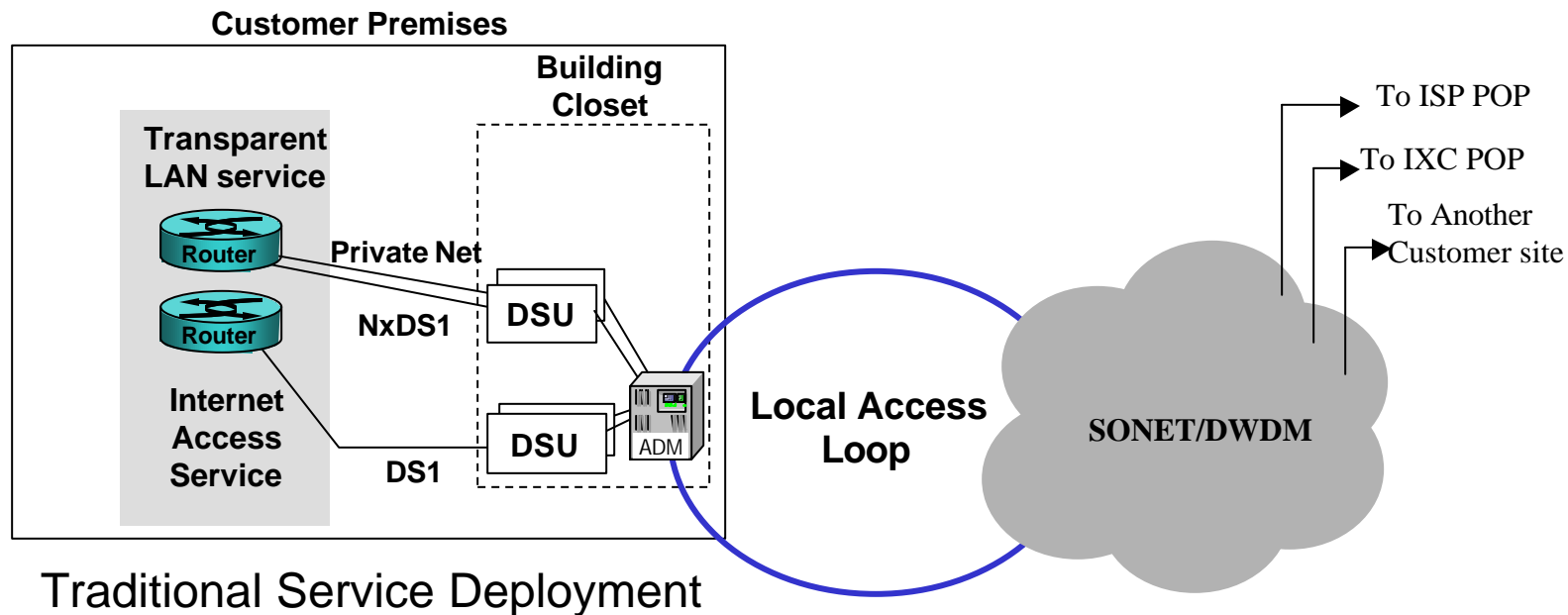

Traditional Service Deployment

DS1 could be TDM, FR or ATM.

Fractional DS1 possible for TDM and FR

FR and ATM may pass through an ATM/FR switch in the core





# MAN/WAN interconnection (Contd.)

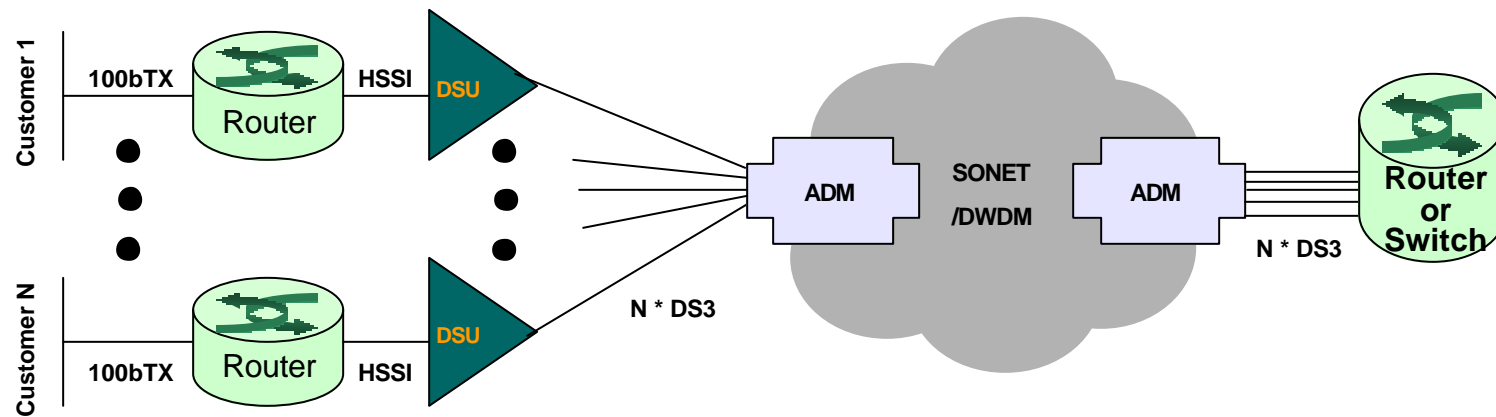



# MAN/WAN interconnection (Contd.)

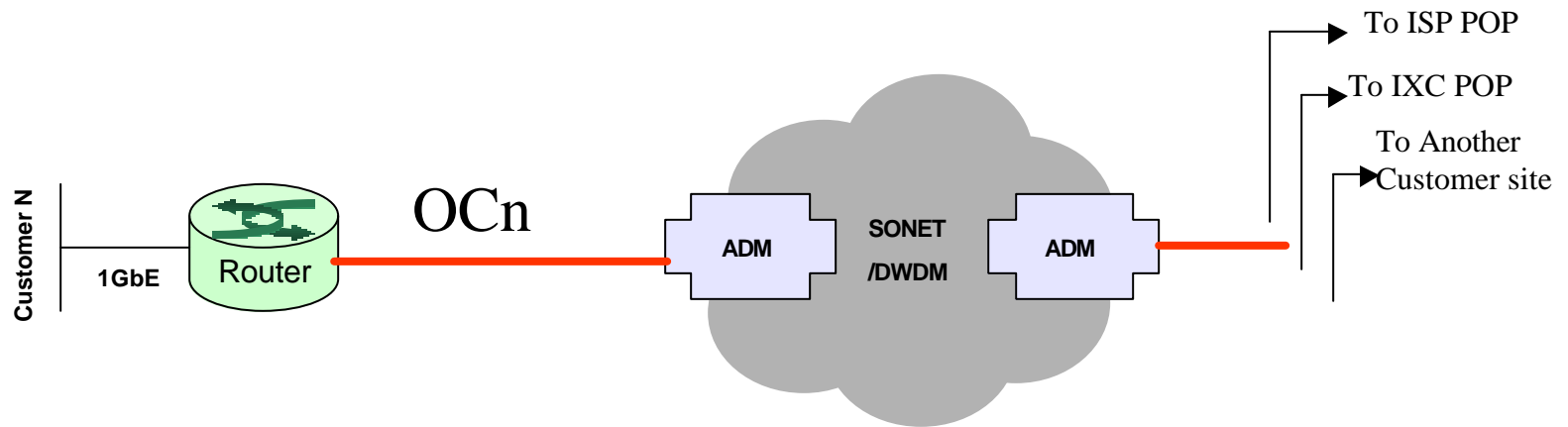

OCn could be POS or ATM.



# ADSL Architecture

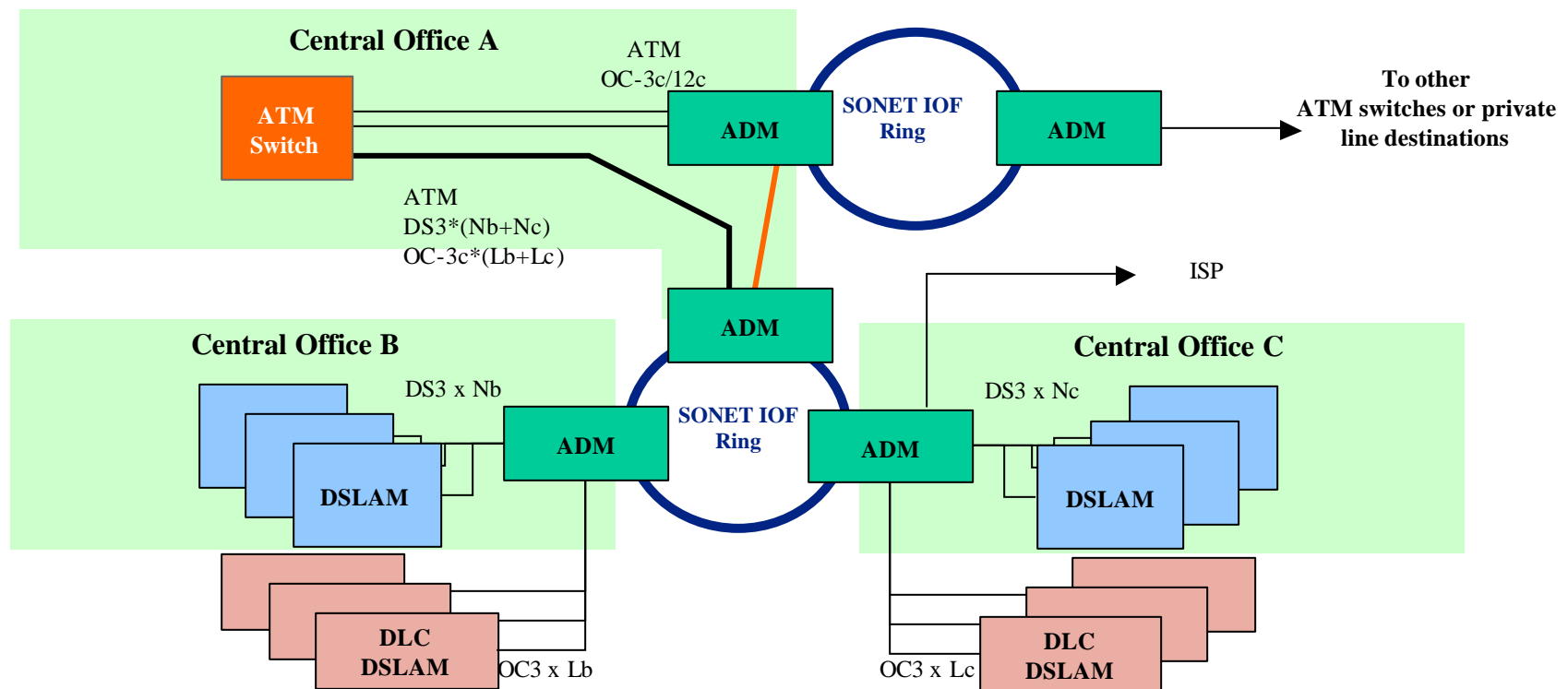



# Current Network Architecture

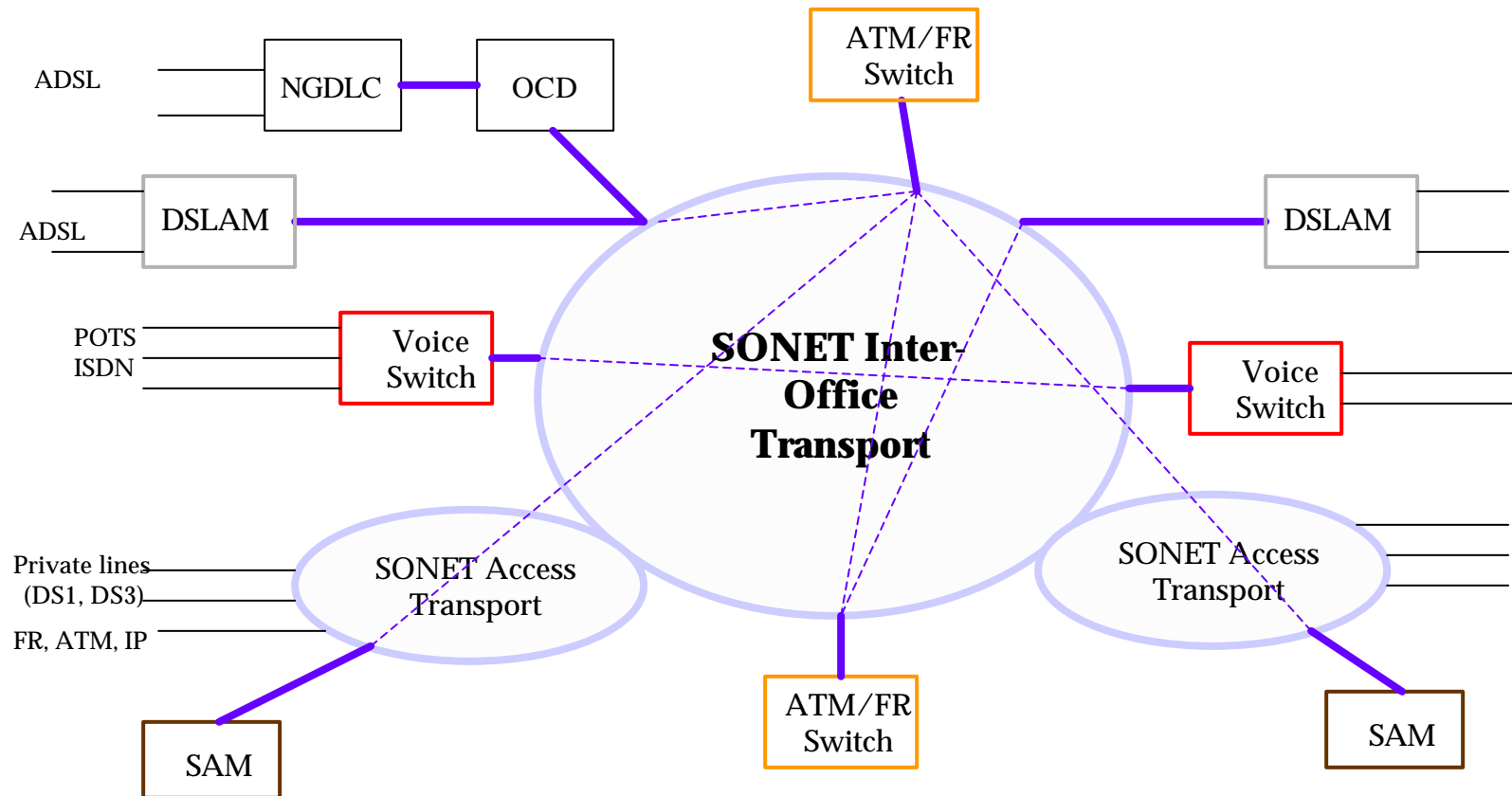



# Typical SBC Transport Network in a Metro

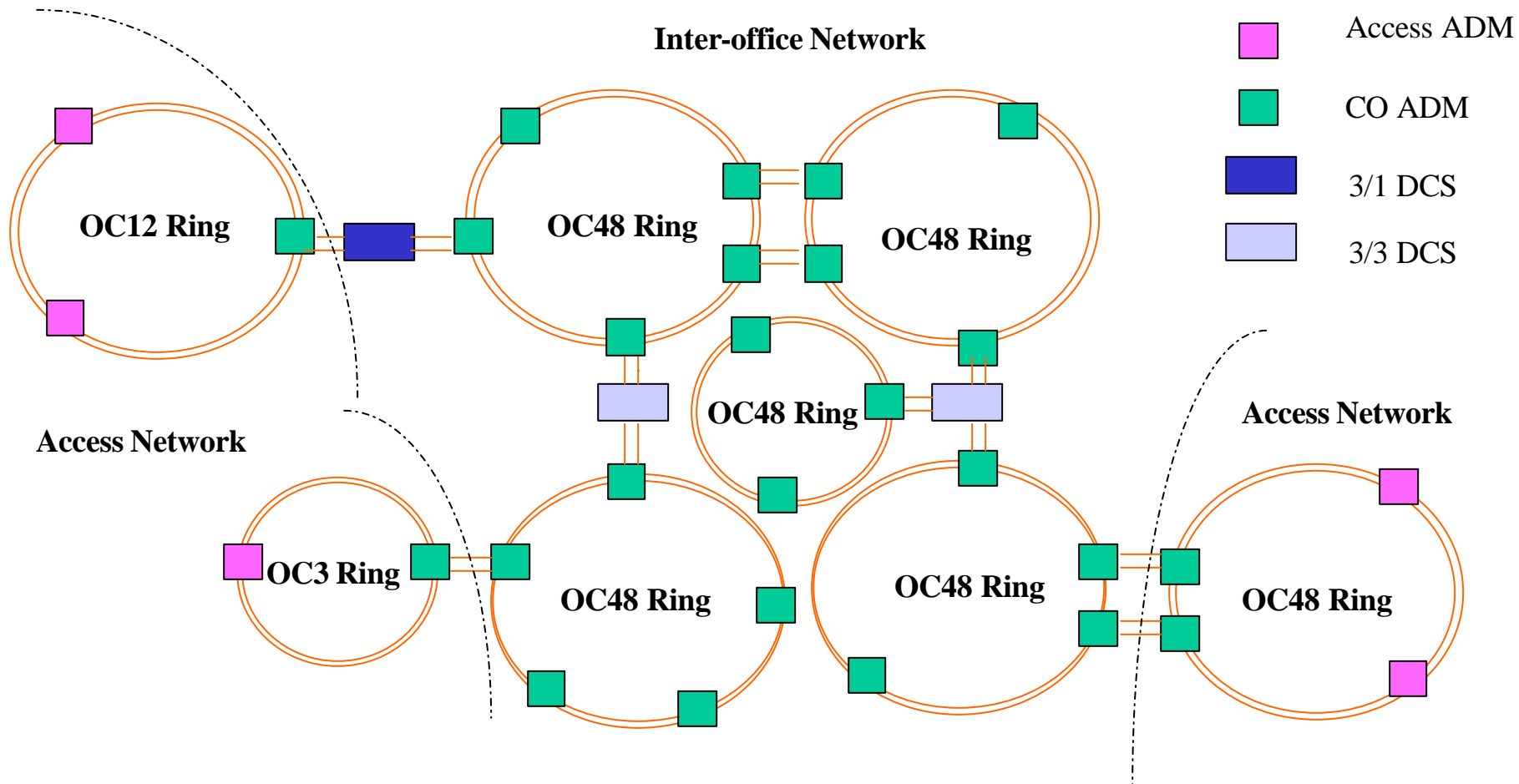



# SBC Native LAN Service

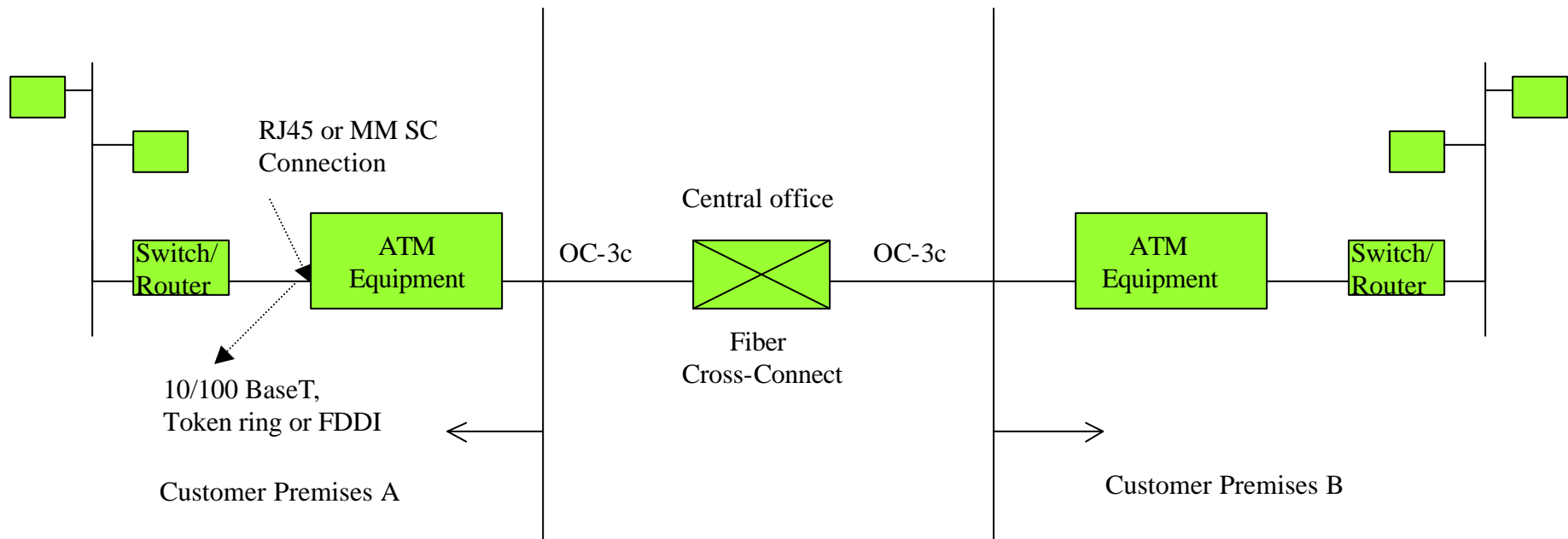





# SBC's GigaMAN: Gigabit Ethernet

- Full Gigabit Ethernet
- Single Point-to-Point Connection
- No Regeneration
- No Protection (or Use 2 Circuits)
- SX Version of IEEE 802.3 (No LX)
- Optical Budget: 29 dB
- 

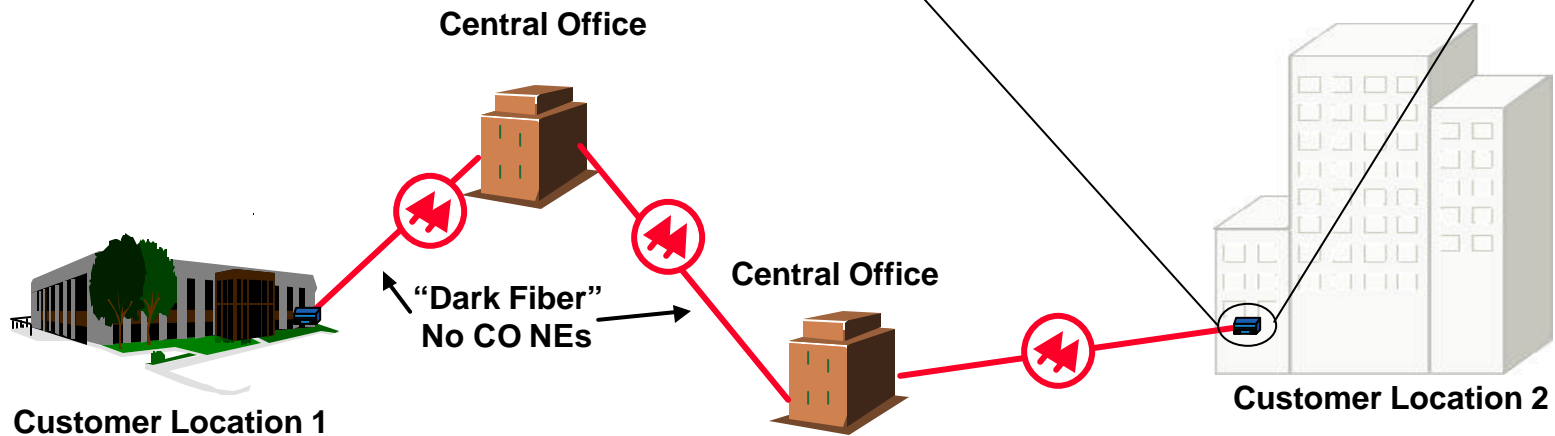
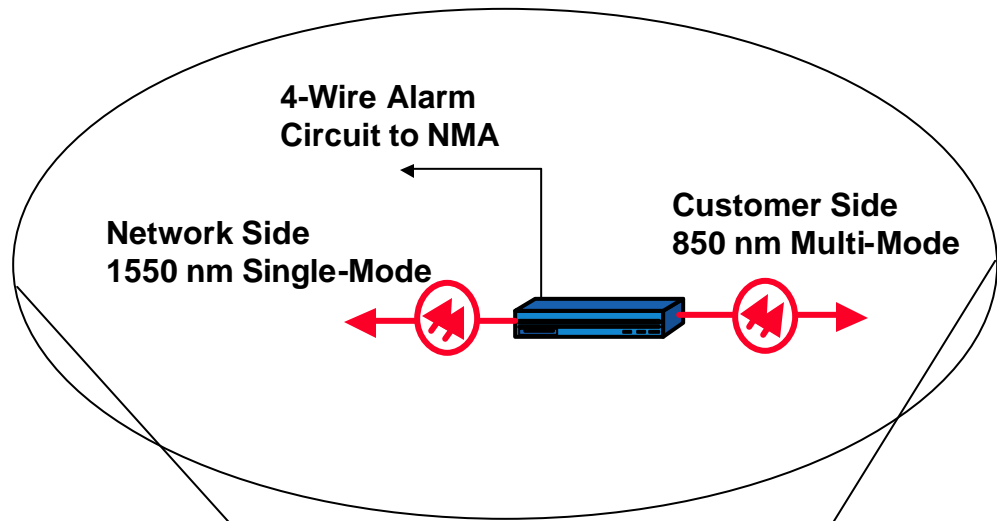



# MON Application

- Multi-service Optical Network -- Customer Dedicated DWDM network
- Targeted for large business customers
  - Storage area networks
  - Large amount of GbE traffic
  - Rapidly growing SONET needs





# Future Shared DWDM Infrastructure

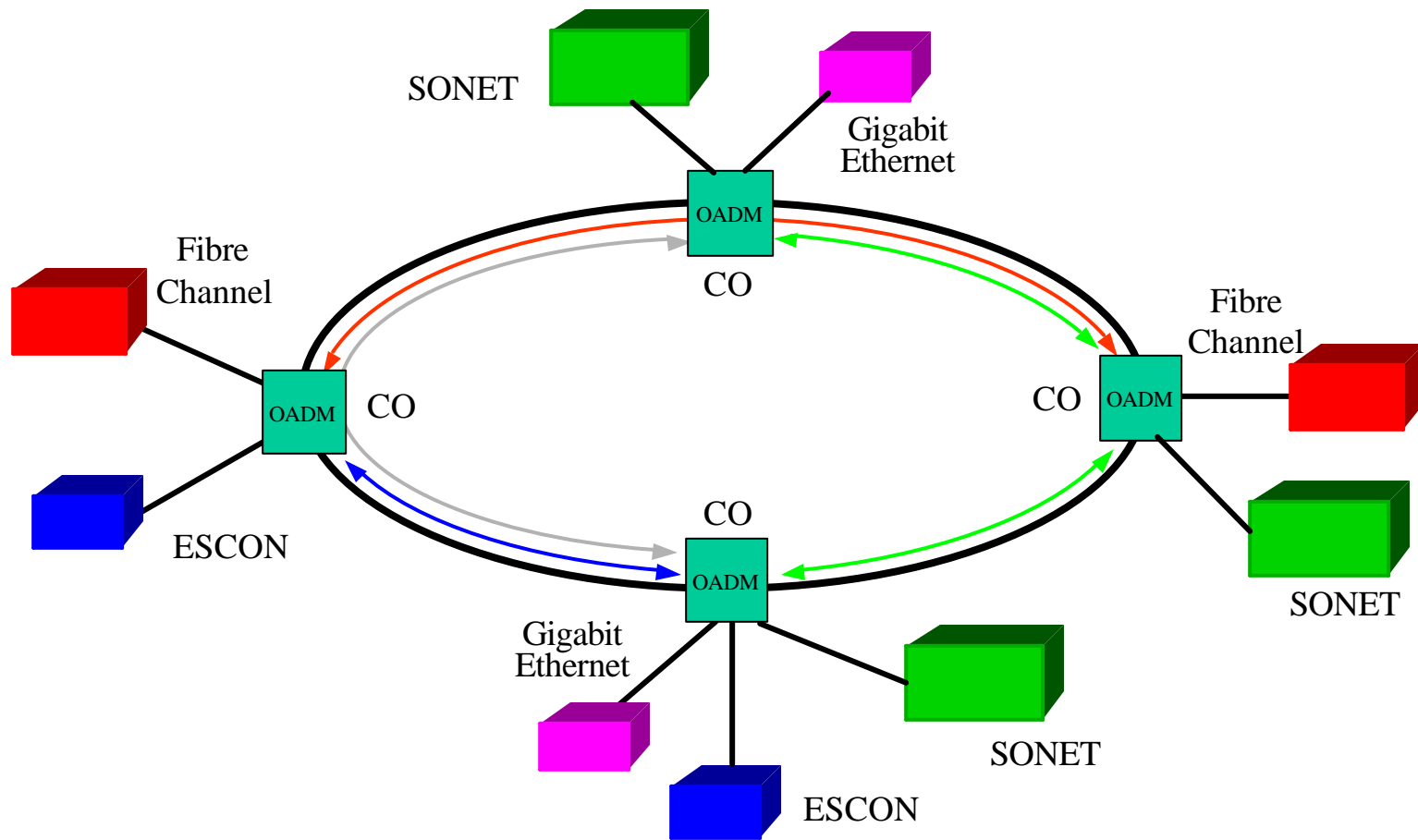



# ATM Passive Optical Network (APON)

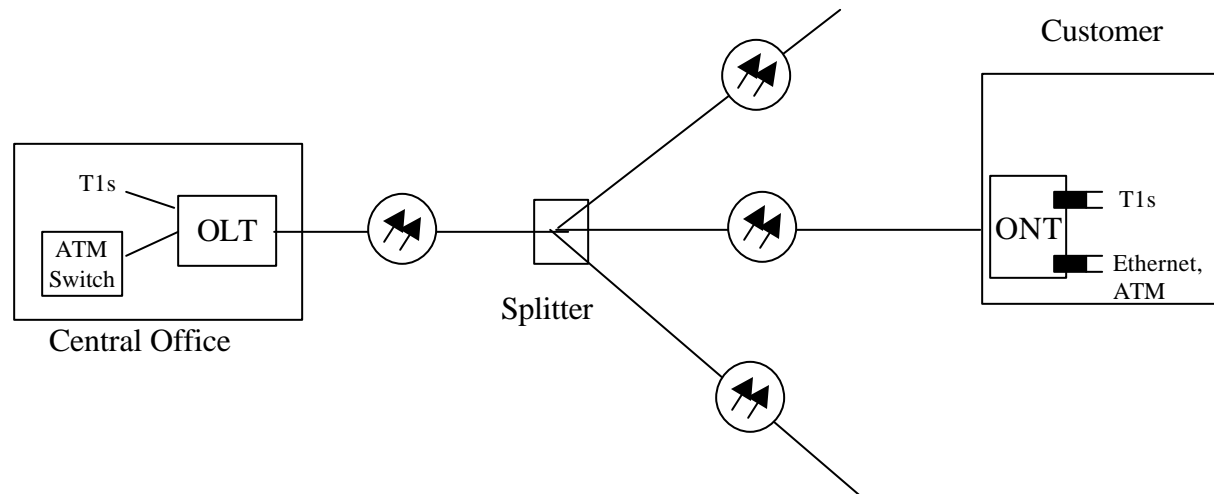



# ATM VP RING

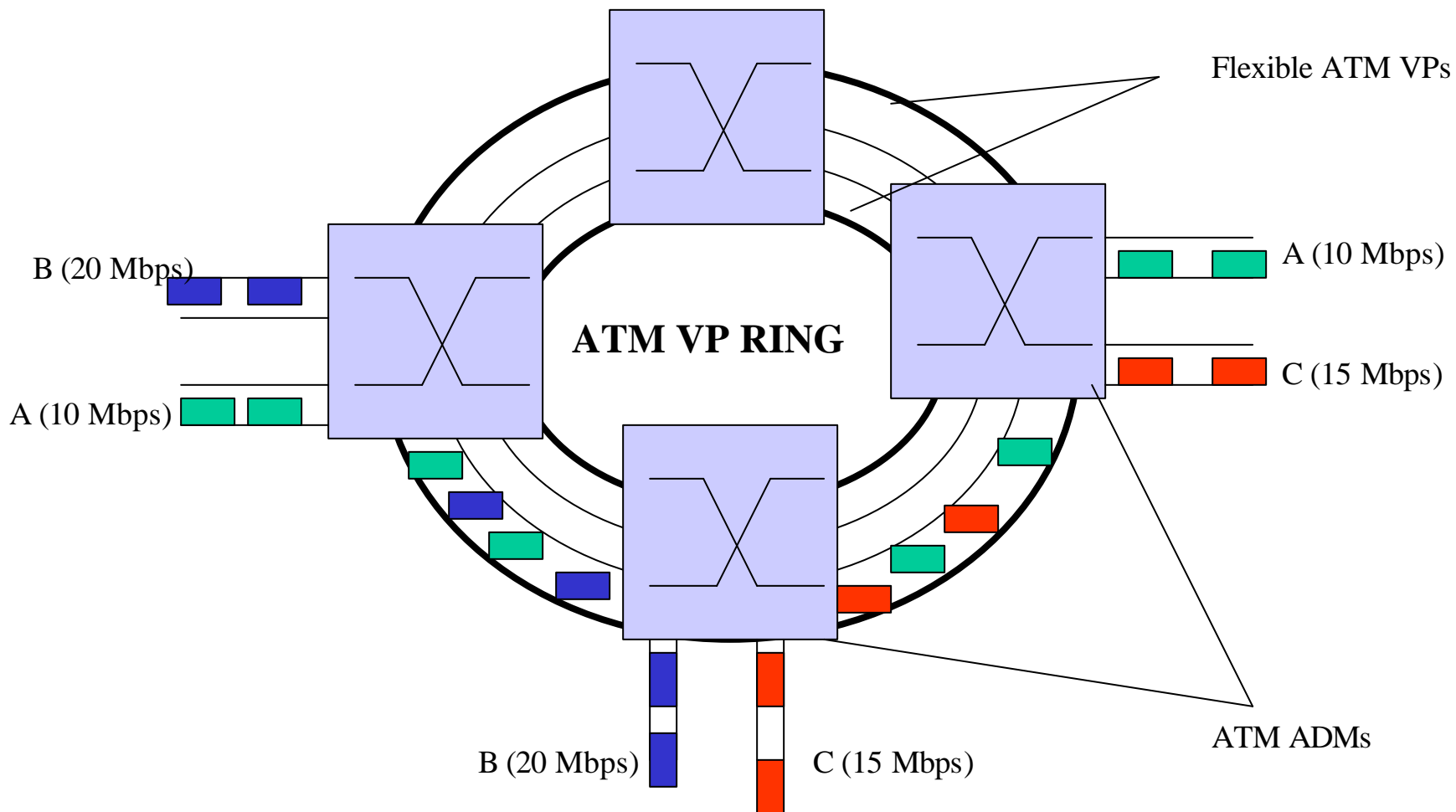



# ATM VP Ring

- ATM is the common transport layer over a “thin” layer of SONET.
- Integration of transport and switch functions at ATM layer
- Support for all types of services (private lines, FR, ATM, voice, IP, etc.)
- Statistical multiplexing for data traffic (without SONET hierarchy)
- ATM VP Protection Switching with 50~100 msec error restoration time
- Protects against ATM layer as well as lower layer defects
- Protection bandwidth could be utilized by best-effort data traffic

A lot of the benefits are similar to what  
RPR hopes to provide





# ADSL Transport with ATM VP Rings

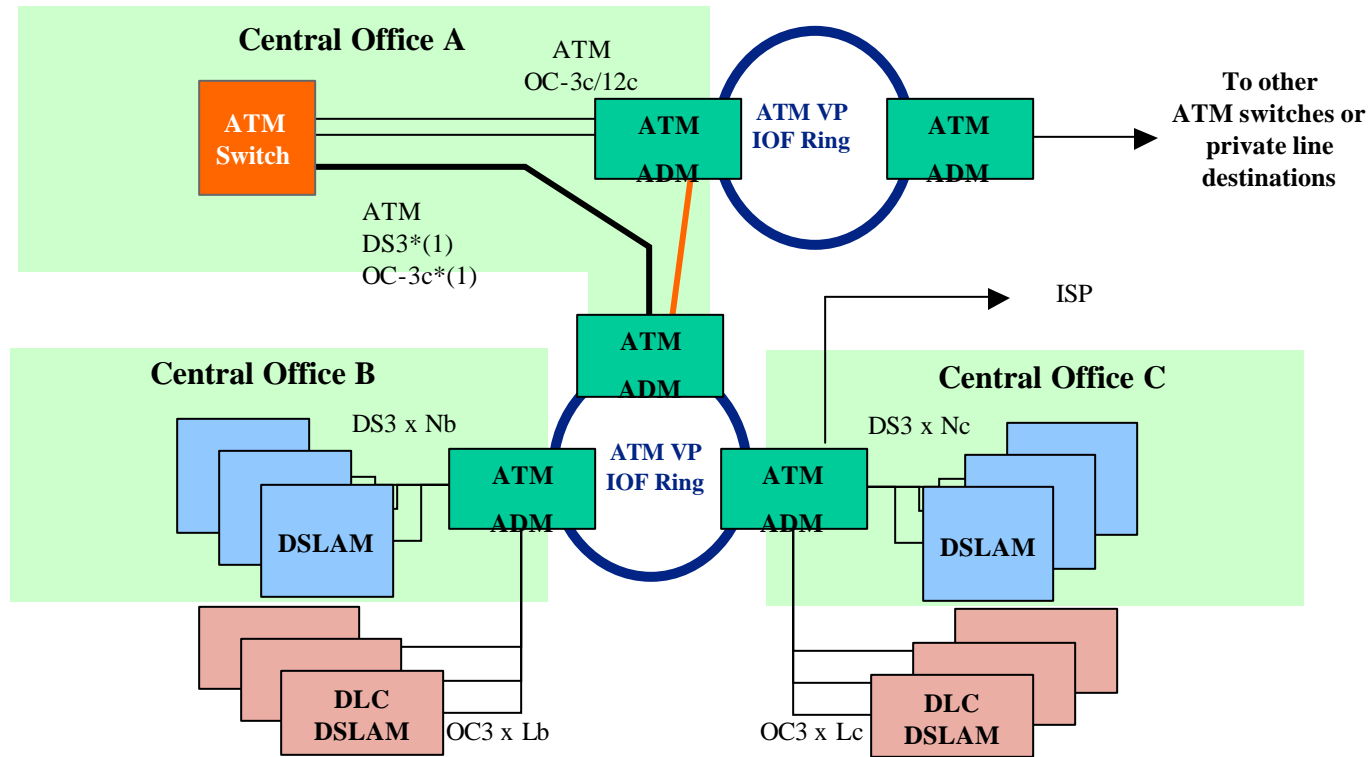

- ATM VP Rings enable the aggregation and multiplexing of lightly loaded DS3 and OC3c circuits.
- This reduces the number of DS3/OC3c circuits & ports on IOF network and ATM switches.
- This also reduces back-hauling, resulting in reduced IOF network and ATM port costs.



## Important reasons why ATM VP Ring business case did not prove in

- Lack of enough ATM sources in the access network
- Adaptation of non-ATM traffic to ATM was expensive
- ATM VP rings were not so attractive in the core as the bandwidth utilization in the ATM “pipes” in the core was high.

**Important Lesson: Do not make RPR too complicated that makes adaptation of traffic to RPR too expensive.**