

Project	IEEE 802.20 Working Group on Mobile Broadband Wireless Access < http://ieee802.org/20/ >	
Title	QTDD Technology Overview Presentation	
Date Submitted	2005-10-28	
Source(s)	Jim Tomcik Qualcomm Incorporated 5775 Morehouse Drive San Diego, California, 92121 Voice: 858-658-3231 Fax: 858-658-2113 E-Mail: jtomcik@qualcomm.com	
Re:	MBWA Call for Proposals	
Abstract	This contribution (part of the QTDD proposal package for 802.20), contains the QTDD Technology Overview Presentation slide set.	
Purpose	For consideration of 802.20 in its efforts to adopt an TDD proposal for MBWA.	
Notice	This document has been prepared to assist the IEEE 802.20 Working Group. It is offered as a basis for discussion and is not binding on the contributing individual(s) or organization(s). The material in this document is subject to change in form and content after further study. The contributor(s) reserve(s) the right to add, amend or withdraw material contained herein.	
Release	The contributor grants a free, irrevocable license to the IEEE to incorporate material contained in this contribution, and any modifications thereof, in the creation of an IEEE Standards publication; to copyright in the IEEE's name any IEEE Standards publication even though it may include portions of this contribution; and at the IEEE's sole discretion to permit others to reproduce in whole or in part the resulting IEEE Standards publication. The contributor also acknowledges and accepts that this contribution may be made public by IEEE 802.20.	
Patent Policy	The contributor is familiar with IEEE patent policy, as outlined in Section 6.3 of the IEEE-SA Standards Board Operations Manual < http://standards.ieee.org/guides/opman/sect6.html#6.3 > and in <i>Understanding Patent Issues During IEEE Standards Development</i> < http://standards.ieee.org/board/pat/guide.html >.	

QTDD Technology Overview

Jim Tomcik

jtomcik@qualcomm.com

Overview – I

- ✓ **Adaptive coding and modulation w/ H-ARQ and turbo coding**
- ✓ **Short retransmission latency**
 - approximately 5.5ms on Forward and Reverse Link
- ✓ **OFDMA Forward Link with MIMO support**
 - single codeword MIMO with closed loop rate & rank adaptation
 - multi-codeword (layered) MIMO with per-layer rate adaptation
 - peak rate over 130Mbps in 20MHz equal partitioning between FL & RL
- ✓ **Quasi orthogonal Reverse Link**
 - orthogonal transmission based on OFDMA
 - non-orthogonal transmission with multiple receive antennas
 - CDMA control channels
- ✓ **Interference management through fractional frequency reuse**
 - improved coverage & edge user performance
 - dynamic fractional frequency reuse to optimize bandwidth utilization

Overview – II

- ✓ **Optimized throughput / fairness tradeoff through power control**
 - distributed power control based on other cell interference

- ✓ **Forward Link precoding & SDMA**
 - MISO / MIMO closed loop precoding with low-rate feedback
 - combined precoding and space division multiple access
 - MISO / MIMO beamforming based on channel reciprocity

- ✓ **Subband scheduling**
 - enhanced performance on Forward & Reverse Link
 - multi-user diversity gains for latency sensitive traffic

- ✓ **CDMA Reverse Link control segment**
 - statistical multiplexing of various Reverse Link control channels
 - fast access with reduced overhead and fast request
 - broadband reference for power control, beamforming and subband scheduling
 - efficient handoff support

- ✓ **Scalable design with an arbitrary bandwidth within 5 - 20MHz**

Outline

- System architecture and protocols
- Security
- RLP
- QoS
- Numerology
- Acquisition
- Resource management
- Forward Link and Reverse Link hopping
- Forward Link control
- Reverse Link control
- Coding and modulation
- Reverse Link power control
- Handoff
- Multi-carrier mode
- Fractional Frequency Reuse
- Subband scheduling
- Forward Link multi-antenna transmission
- Quasi orthogonal Reverse Link with multiple receive antennas

System Architecture

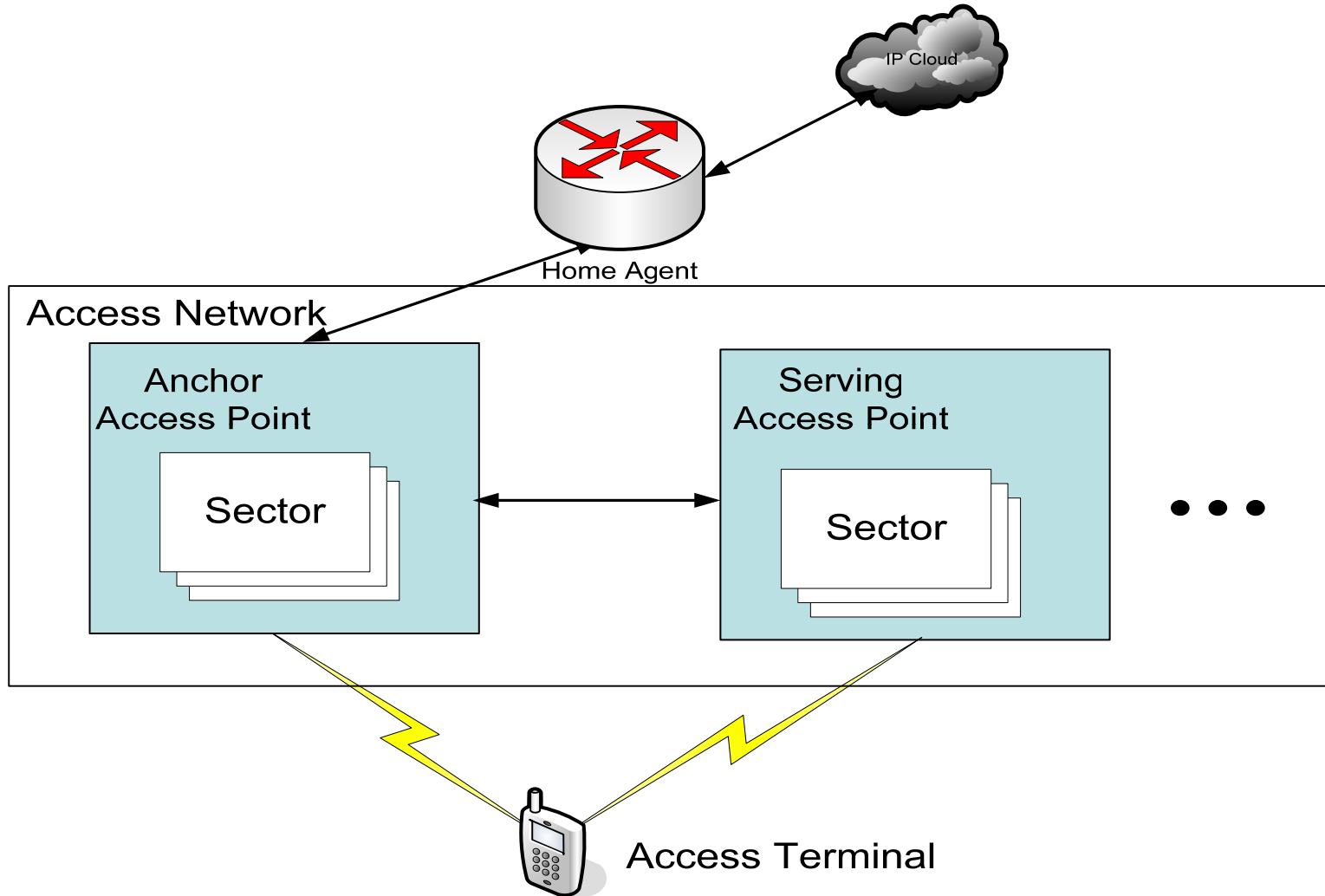

Anchor and Serving AP

- Serving Access Point contains the sector that
 - Provides air interface attachment for the AT.
 - Can be different for FL and RL
 - Changes based on radio conditions.
- Anchor AP is
 - The internet attachment point for the AT.
 - May change to minimize the number of hops a packet needs to traverse to reach the AT.

Layer 1,2,3 Handoff

- Layer 1 handoff
 - AT requesting a different FL or RL serving sector via RL control channels.
 - Target serving sector completes with assignment of traffic resources
- Layer 2 handoff
 - Changing FL or RL serving sector.
- Layer 1 and Layer 2 handoff always happen together.
- Layer 3 handoff
 - Changing the Anchor Access Point
 - Involves HA binding update.
 - Occurs asynchronously to the Layer 1,2 handoff.
 - MBWA air interface protocols support make before break Layer 3 handoff.

AT Addressing

- Addresses used by an AT
 - UATI (128 bits) Universal Access Terminal Identifier.
 - A non-user specific identifier assigned by the Access Network
 - Used for system access.
 - ATI (lower 32 bits of UATI) Access Terminal Identifier
 - Used for paging.
 - MAC ID (11 bits)
 - Assigned by each sector in Active Set.
 - Used during connected state.
- Optionally the AT may have the following addresses which are not used for operation of the MBWA system.
 - IEEE EUI-64 or EUI-48
 - IP Address

Session vs. Connection

- **Opening a MBWA session** is analogous to calling your favorite bank for the first time and opening an account (exchange some related information).
- Even after hanging up the phone, you still have an account with the bank with account ID (**UATI**).
- You may call your bank many many times after opening the account for various transactions, but you don't have to exchange all the information that you exchanged with the bank on the first day.
- The subsequent calls to the bank are analogous to establishing **connection**.
- Each time you call the bank, you present some sort of certificate (i.e., your mother's maiden name) which proves to the bank that you are telling the truth about your identity. This is analogous to the **authentication** procedures

AT States

- Connected
 - AT is assigned a MAC ID from at least one sector.
 - AT transmits RL control channel and is power controlled.
 - FL traffic resources can be assigned in one phy frame.
- Monitor
 - AT monitors overhead channels regularly.
 - AT needs an access for unicast communication.
 - AN may only page the AT to establish communication.
- Idle (Sleep)
 - Same as Monitor except,
 - AT monitors overhead channels according to a predetermined schedule (sleep cycle).

Protocol Layering

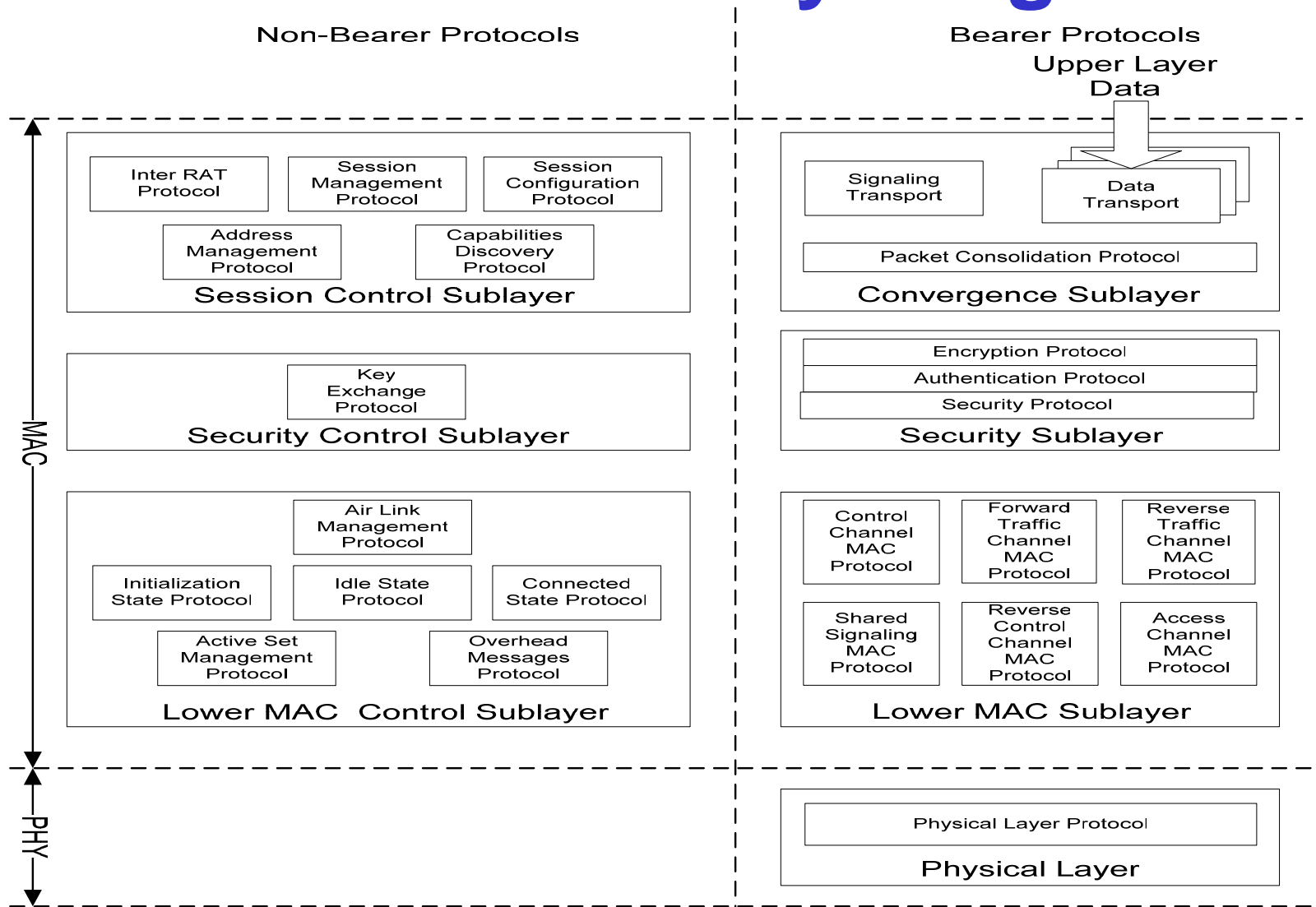

Packet Framing

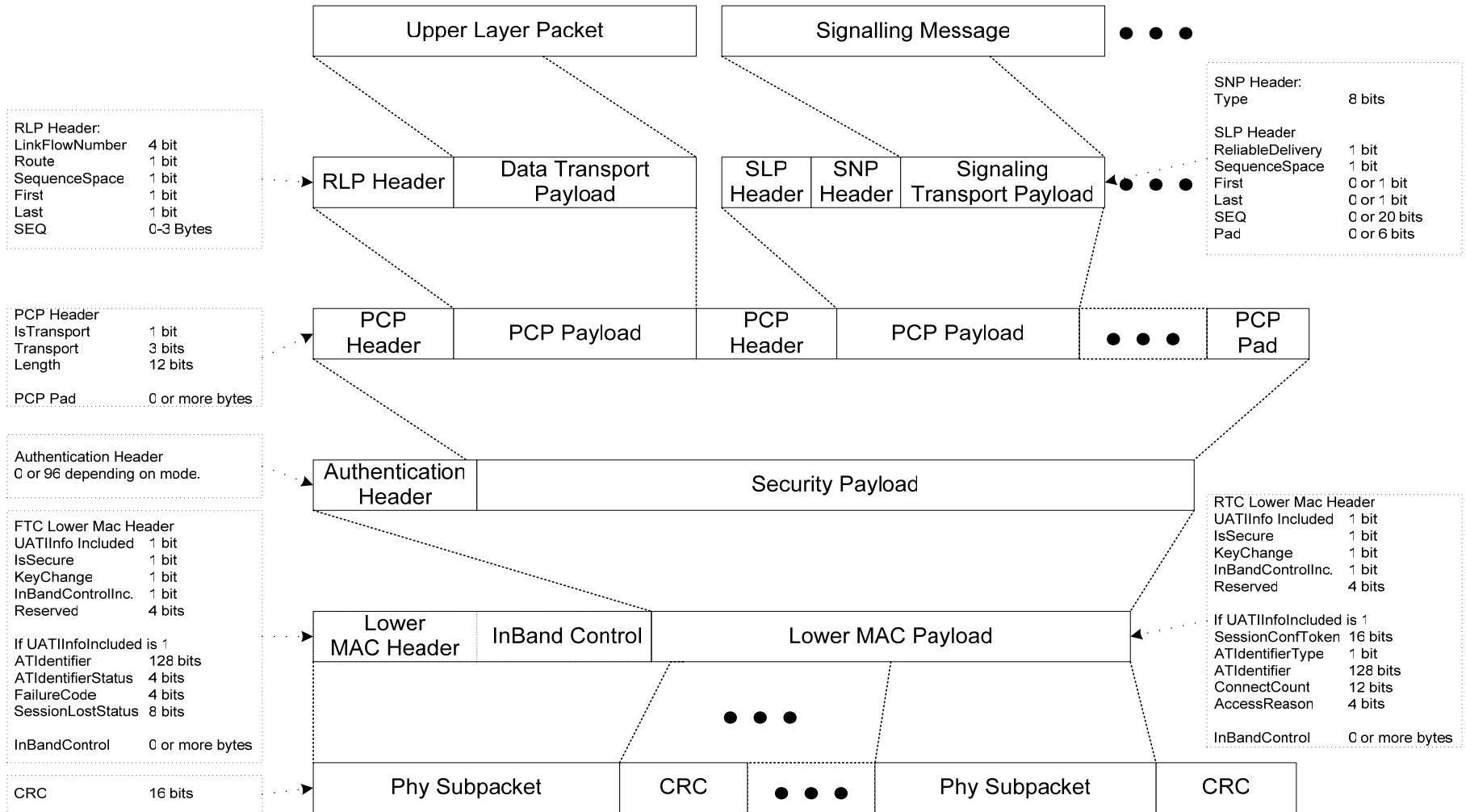

Security Overview

- Security Master keys negotiated by LEAP or PANA
- 4-Way handshake to derive OTA keys
- Cryptosync based on system time and other system parameters
 - No over the air crytposync overhead
- Encryption with AES
- Authentication with SHA-1

RLP

- RLP (Radio Link Protocol) is used to provide
 - Fragmentation and reassembly of upper layer packets, which allows for progress on fragment level even through Layer 1,2 handoff.
 - Increase the link layer reliability through NACK and optionally ACK based messaging.
 - In order delivery of upper layer packets even through Layer 1,2 handoff.
 - Multiple parallel flows for QoS support.
 - RLP framing can be performed at the serving AP, reducing round trip delays for NACKs.

QoS – Architecture

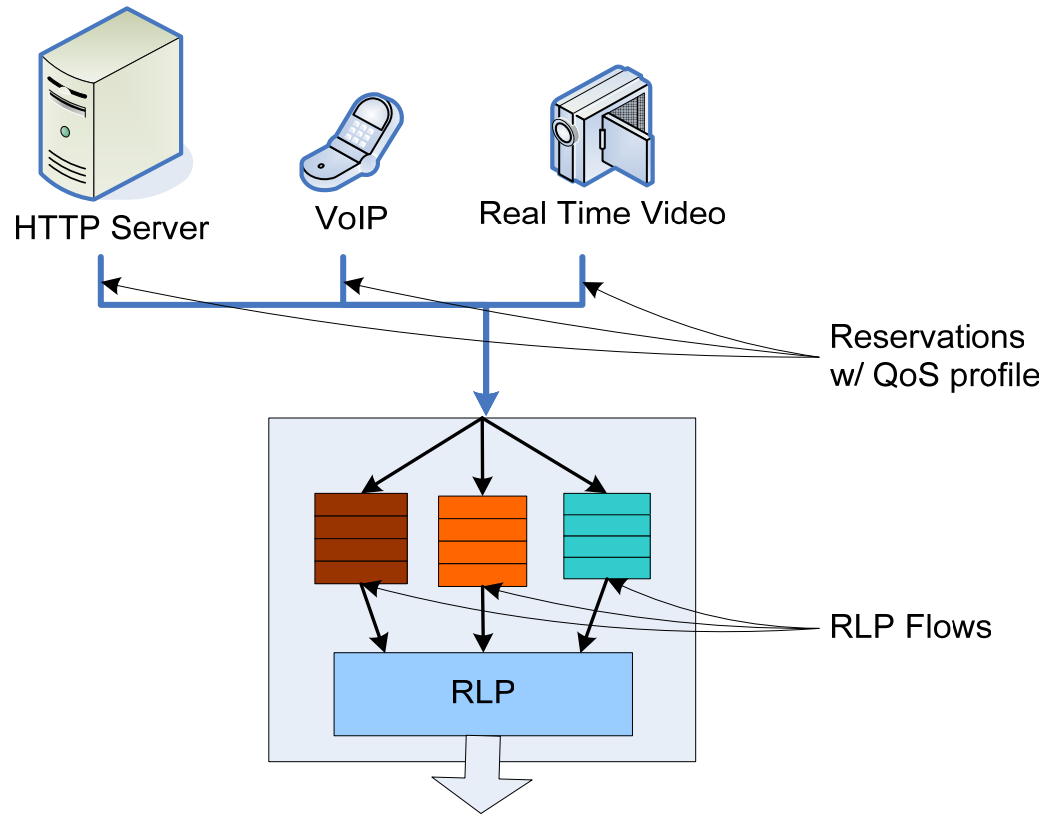

- Main QoS operations are:
 - Configuration and removal
 - Activation and deactivation

- A packet stream requiring QoS is associated with a reservation.
 - A filter maps a reservation to a flow
- Flows are configured for different QoS service types
 - Multiple reservations may map to a single flow
 - Data Transport defines 15 flows
- All QoS reservations are initiated by the access terminal
 - Access network may suggest a QoS setting
- Attributes are defined independently for the forward and reverse links
- Supports Diffserv and Intserv (e.g. RSVP) architectures.

QoS – Configuration

- Configuration of a flow or reservation may be done independently from activation.
 - Attribute values are a function of the QoS authorization for the access terminal and system operator policies.
 - Should be done in advance for quick activation
 - Some attributes may be modified after flow is active.
- The access terminal signals to access network the
 - Service flow requirements (Reservation*KK*QoSRequest) and
 - Packet filter (Reservation*KK*PacketFilter for forward link only)
- The access network may suggest new reservations to the access terminal.
- Reservations may be removed and reused to support a different QoS service type.

OFDM Symbol Numerology

Parameter	512 pt FFT	1024 pt FFT	2048 pt FFT	Units
Chip rate	4.9152	9.8304	19.6608	Mcps
Subcarrier spacing	9.6	9.6	9.6	kHz
Bandwidth of Operation	≤ 5	≤ 10	≤ 20	MHz
Guard carriers	Depends on bandwidth	Depends on bandwidth	Depends on bandwidth	
Cyclic Prefix	6.51 – 26.04	6.51 – 26.04	6.51 – 26.04	μs
Windowing Duration	3.26	3.26	3.26	μs
OFDM Symbol Duration (For 6.51 μs CP)	113.93	113.93	113.93	μs
Guard time (FL->RL)	78.12	78.12	78.12	μs
Guard time (RL->FL)	16.28	16.28	16.28	μs

- Three basic FFT sizes and chip rates
- Different operating bandwidths supported through flexible use of guard carriers

Superframe Structure

- The system supports TDD M:N modes for generic values of M and N. M:N refers to the time-partitioning between forward and reverse links.
 - In TDD M:N, M consecutive FL PHY Frames alternate with N consecutive RL PHY Frames.
 - Each PHY Frame consists of 8 OFDM symbols.
 - We show the superframe structure and HARQ retransmission structures for 1:1 and 2:1 in the following slides.
- In TDD 1:1, a superframe consists of a superframe preamble followed by 12 FL and 12 RL PHY Frames.
- In TDD 2:1, a superframe consists of a superframe preamble followed by 16 FL and 8 RL PHY Frames.
- Superframe preamble carries PN codes and overhead channels for initial acquisition.

Superframe Structure (1:1 and 2:1)

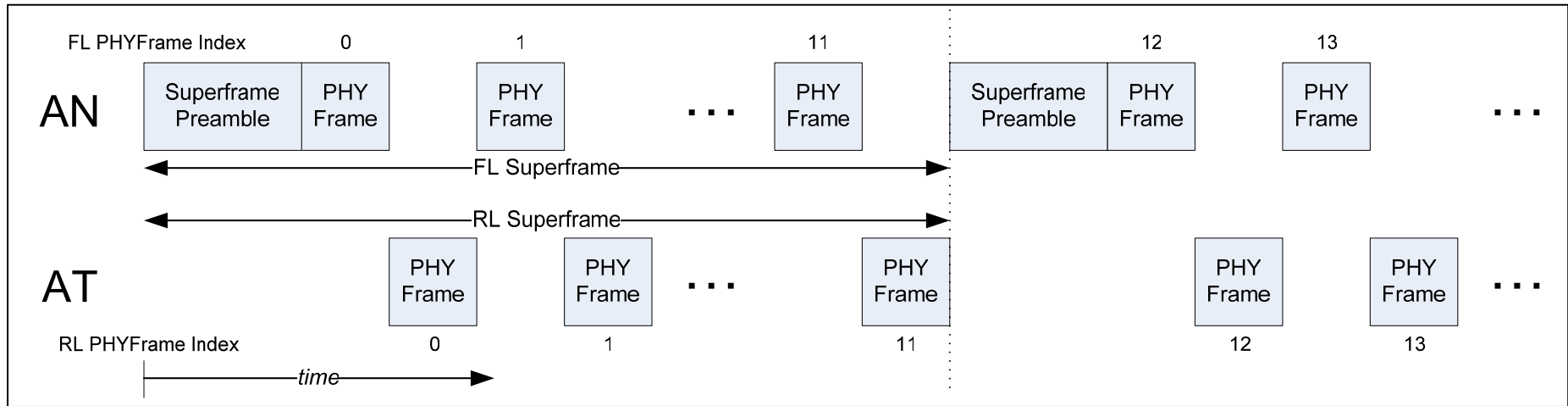

1:1 (above) and 2:1 (below)

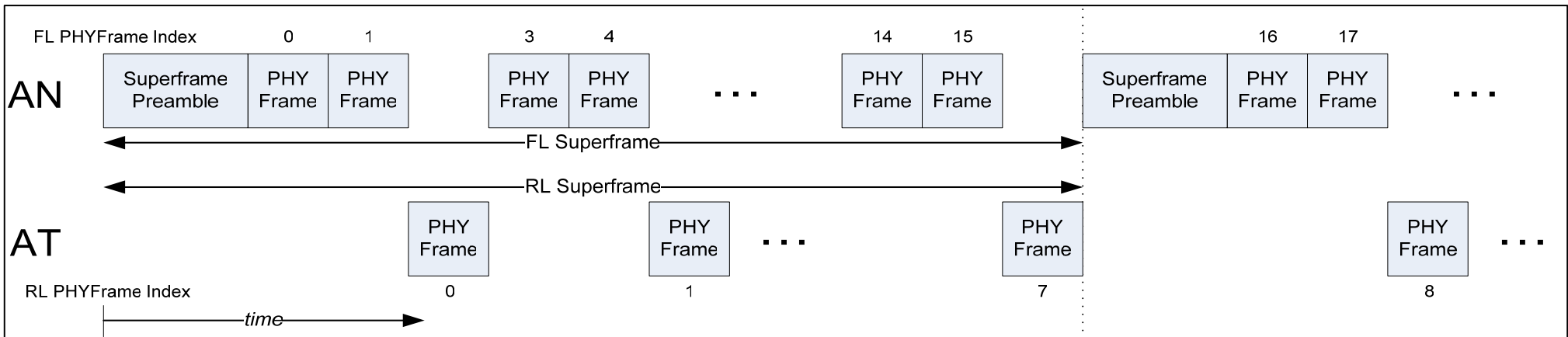

Forward Link Timeline (1:1)

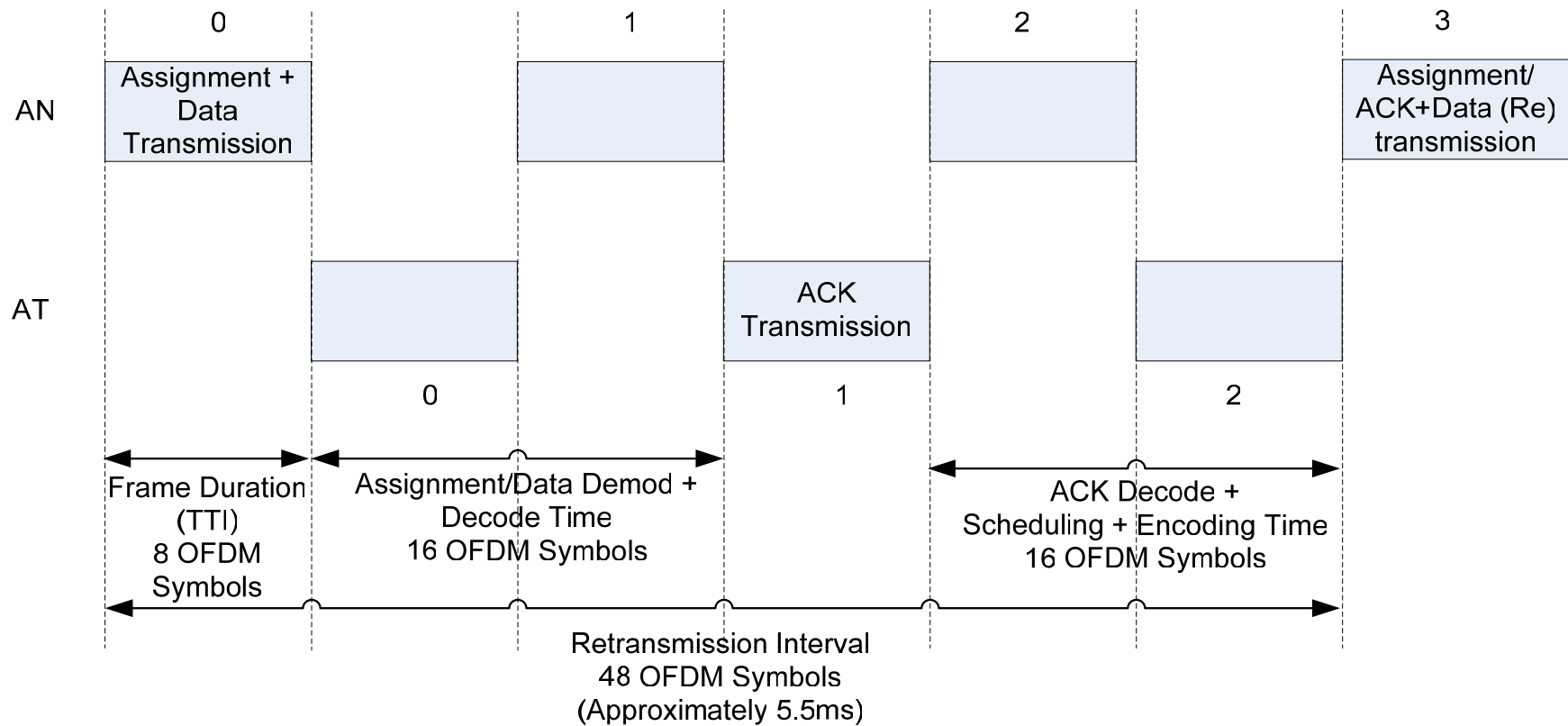

Reverse Link Timeline (1:1)

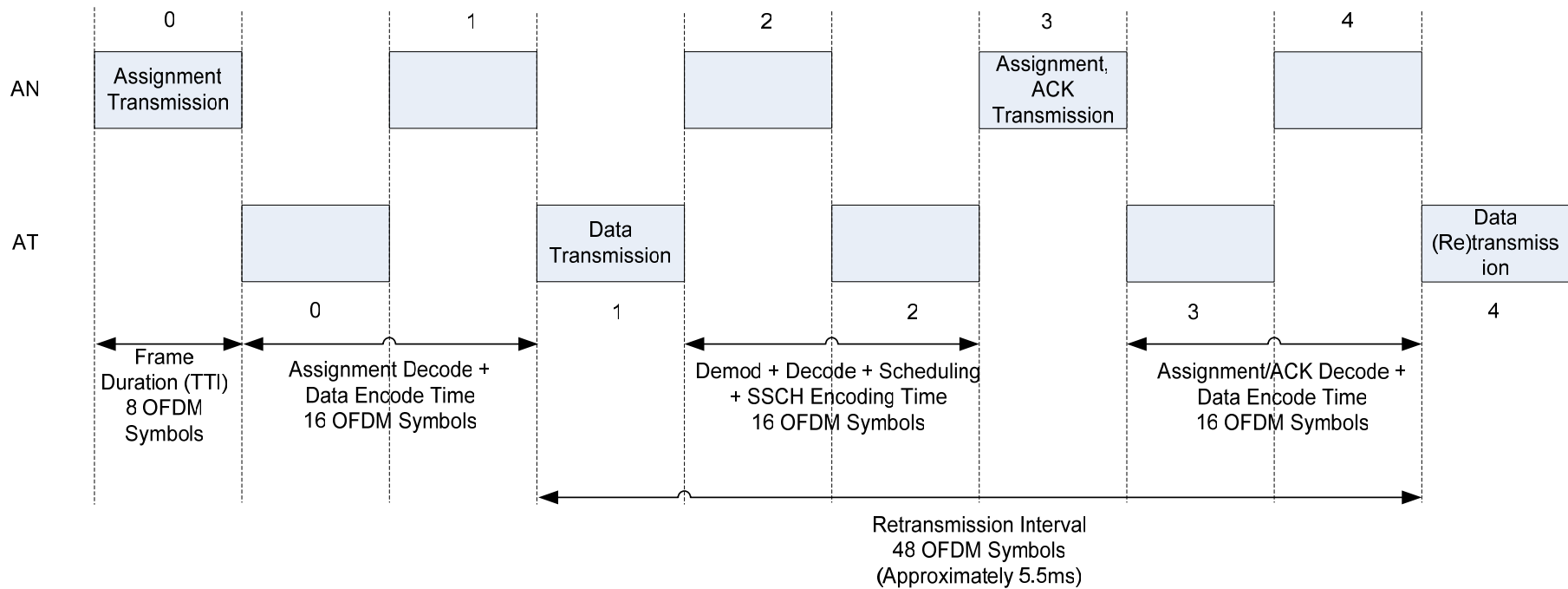

Forward Link Timeline (2:1)

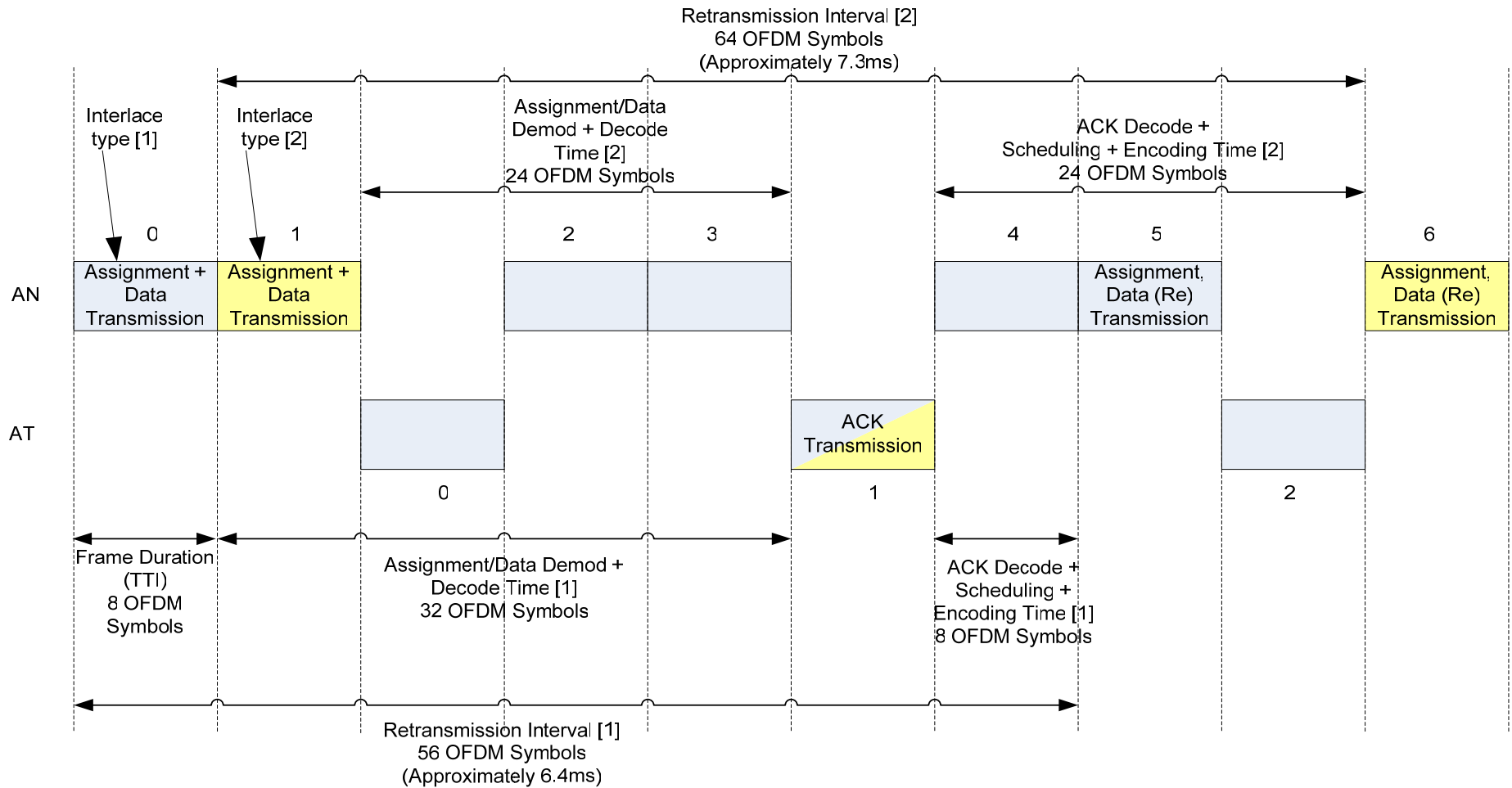

Reverse Link Timeline (2:1)

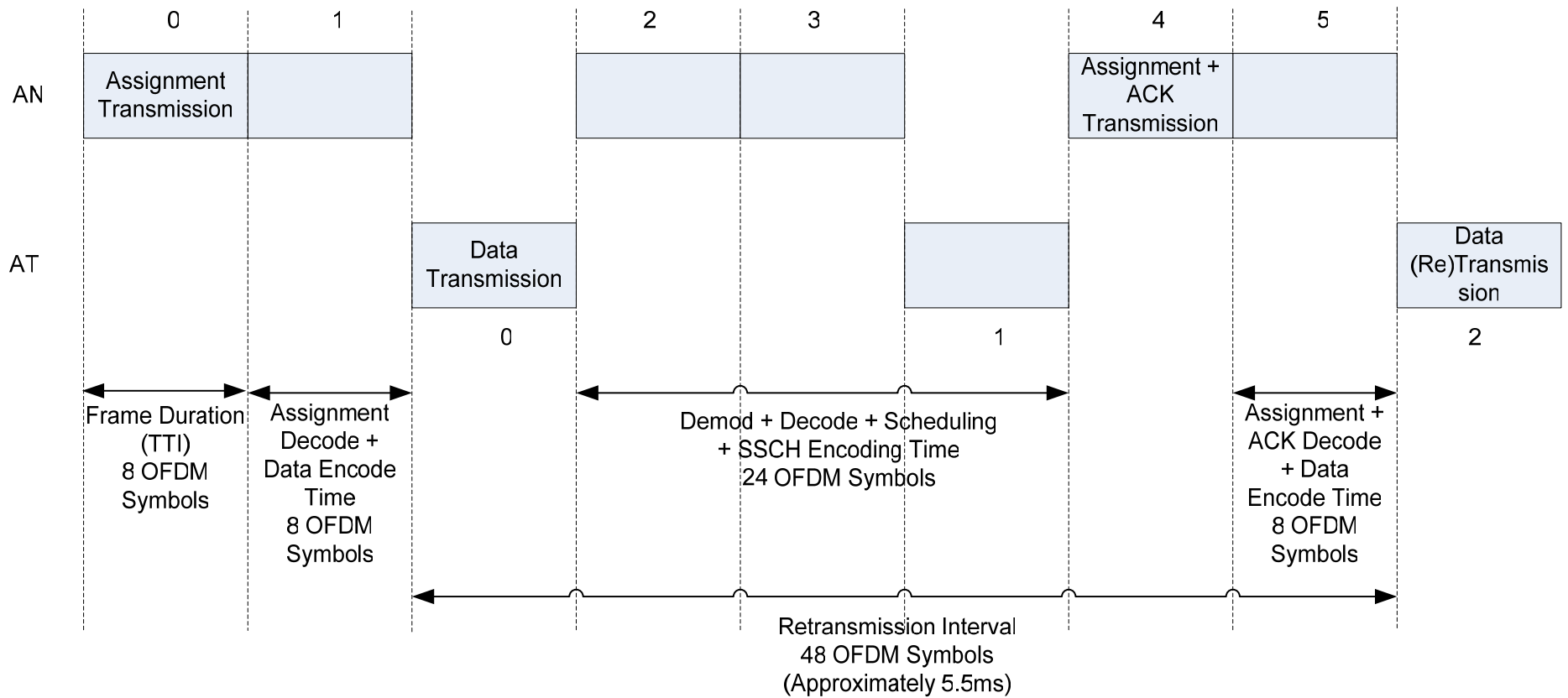

Superframe Numerology

Parameter	TDD 1:1	TDD 2:1	Units
PHY Frame Duration (For 6.51 μ s CP)	8	8	OFDM Symbols
	911.46	911.46	ms
Superframe Preamble Duration (26.04 μ s CP)	8	8	OFDM Symbols
	1.07	1.07	ms
Superframe Duration	24	24	PHY Frames
	24.08	23.70	ms
Number of HARQ interlaces (FL/RL)	3/3	5/2	
Retransmission Interval (FL/RL)	6/6	(7 or 8)/6	PHY Frames
	5.75/5.75	(6.57 or 7.57)/5.66	ms

- Does not depend on FFT size
- Superframe duration in PHY Frames is not same for all modes. (same for 1:1 and 2:1)

Forward Link Channels

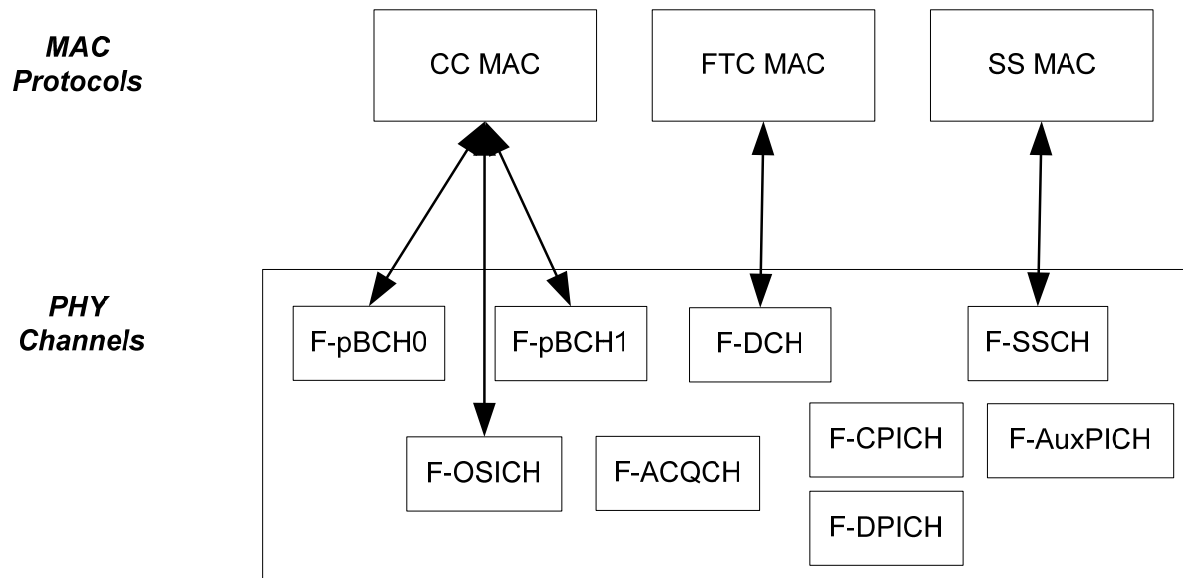

- pBCH0** – broadcast channel, carries deployment specific parameters
- pBCH1** – broadcast channel, carries sector specific parameters
- F-OSICH** – broadcast channel, carries indication of inter-sector interference
- F-ACQCH** – acquisition channel
- F-CPICH** – common pilot channel
- F-DPICH** – dedicated pilot channel
- F-AuxPICH** – auxiliary common pilot channel
- F-SSCH** – shared signaling channel, carries Forward Link control signaling
- F-DCH** – data (traffic) channel

Reverse Link Channels

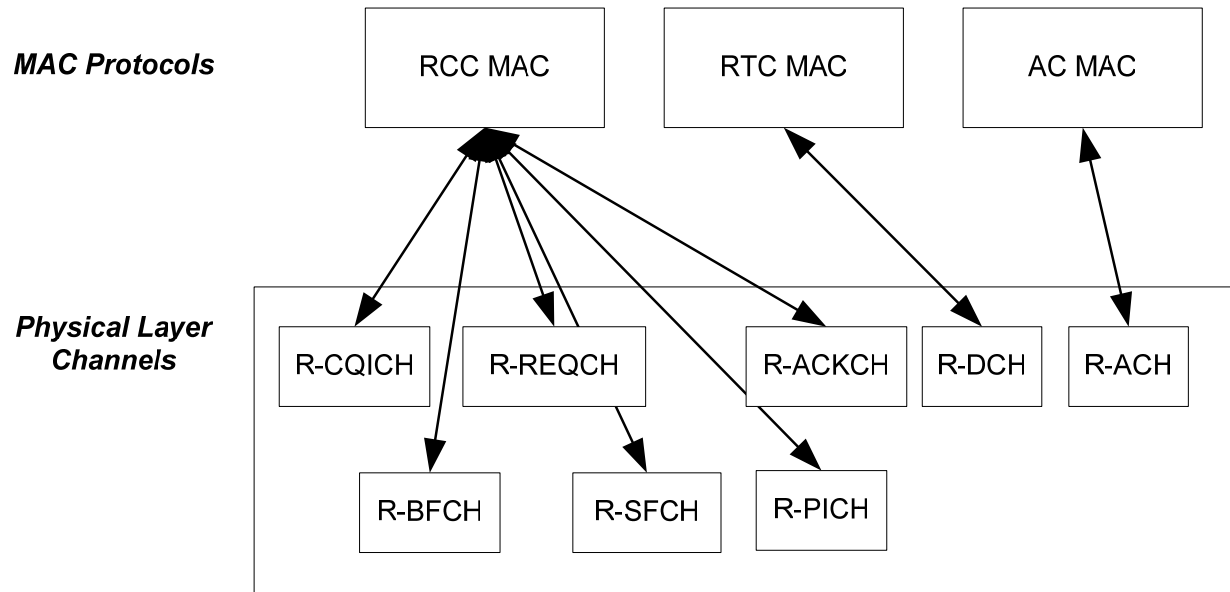

- R-CQICH** – Forward Link channel quality indicator channel
- R-REQCH** – requests Reverse Link resources
- R-BFCH** – feedback channel in support of Forward Link precoding and SDMA
- R-SFCH** – feedback channel in support of Forward Link subband scheduling
- R-PICH** – Reverse Link broadband pilot channel
- R-ACKCH** – Reverse Link acknowledgement in support of Forward Link H-ARQ
- R-ACH** – Reverse Link access channel
- R-DCH** – Reverse Link data (traffic) channel

Superframe Preamble Structure

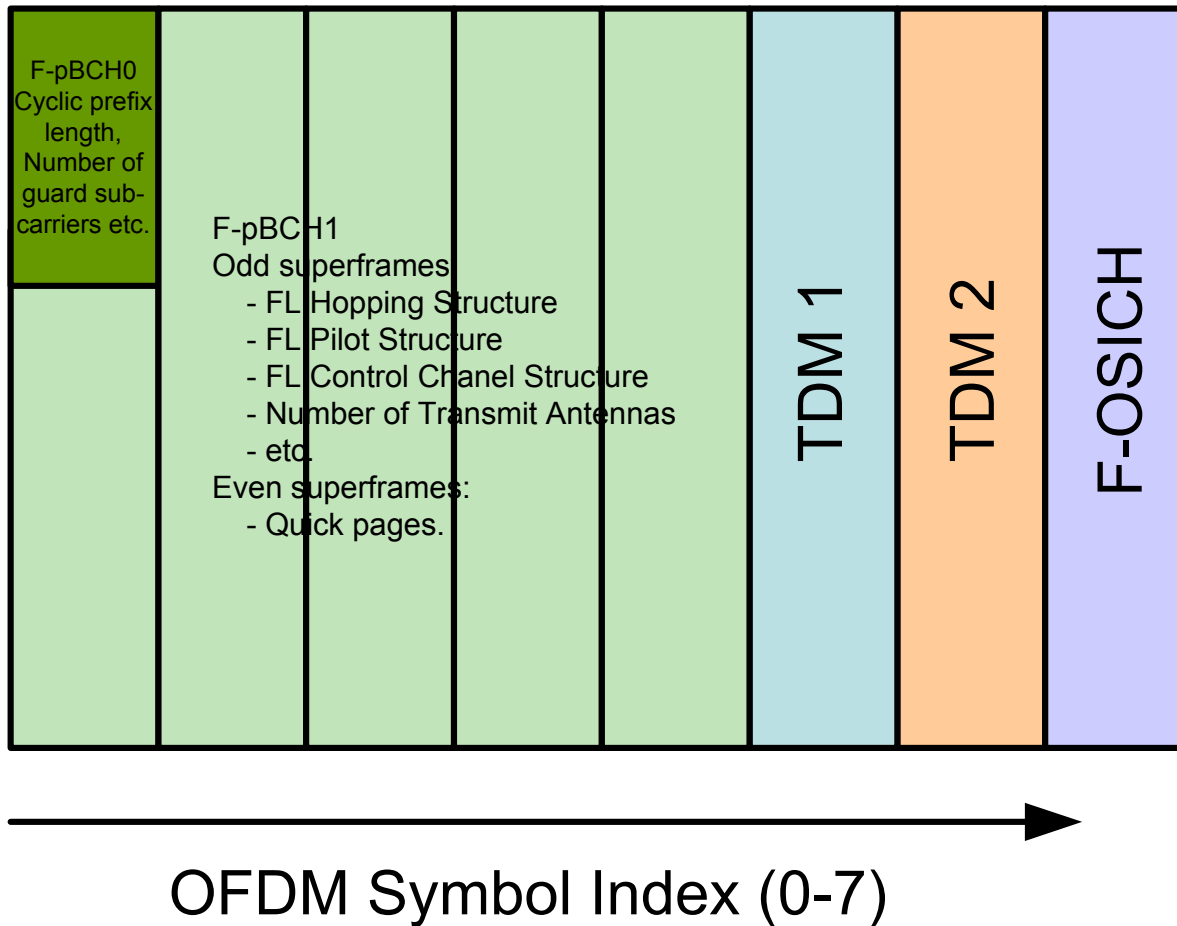

Pilot Structure

- Three TDM pilots: TDM1, TDM2, TDM3 (F-OSICH)
- TDM 1: Periodic pilot – delayed correlation provides low-complexity initial detection as well as frequency synchronization
- Periodic pilots from different sectors add up to generate another periodic waveform
 - Delayed correlation sees only thermal noise in a synchronous network
- Hierarchical pilot structure:
 - Large number of distinct PN codes (12 bits = 4096 codes) to simplify PN planning
 - Low-complexity search algorithm enabled by hierarchical pilot structure
 - TDM1 is scrambled using two bits of the PN code, TDM2 is scrambled using 8 bits of the PN code, TDM3 scrambled using all 12 bits of the PN code
 - Acquisition pilots have a low overhead: about 1.5%
 - TDM pilots change from superframe to superframe
 - Sequence of pilots repeats every 4096 superframes
 - Different sectors use offsets of the same sequence
- Pilots designed for mean detection times of less than 50ms in typical scenarios

Acquisition Procedure

- Superframe preamble carries channels F-pBCH0 and F-pBCH1
 - F-pBCH0 carries deployment-wide static parameters like cyclic prefix duration, number of guard carriers, time-partitioning etc, in addition to the superframe index
 - Required only on initial wakeup, coded over 16 superframes
 - F-pBCH1 carries sufficient information to enable the AT to demodulate FL data from the PHY Frames
 - Info on FL hopping patterns, pilot structure, control channel structure, transmit antennas, etc
 - This info is transmitted every alternate superframe; other superframes used to carry pages
 - Remaining overhead information broadcast using a regular data channel in predefined superframes
 - Carries information on RL hopping patterns, channel mapping, transmit powers, power control parameters, access parameters, etc
- These channels enable a flexible physical layer
 - Can configure cyclic prefix, number of antennas, pilot structure, etc
 - Support FL and RL control channels with flexible overheads, which can be matched to the current user loads
 - Can enable or disable features like sub-band scheduling, FFR etc

Resource Management

- Resource allocation including rate determination centralized at AP for both forward and reverse links
 - For FL, based on FL channel quality reports from AT
 - For RL, based on measurements of RL channel quality as well as RL feedback from the AT including resource requests
 - Network assigns FL and RL resources via Shared Signaling Channel (F-SSCH)

- Scheduler goals
 - Maximize system capacity
 - Manage QoS requirements such as AT throughput and latency
 - Maintain fairness across ATs with widely disparate channel qualities
 - Design ensures that the scheduler has information required to utilize features such as sub-band scheduling, fractional frequency reuse, precoding, and SDMA to achieve the above goals

Assignment Management

- Fundamental unit of assignment is hop-port

- A static resource that maps to a unique physical subcarrier
- Mapping of hop-port to subcarrier can change over time (hopping)
- Sets of hop-ports are specified using nodes on a channel tree

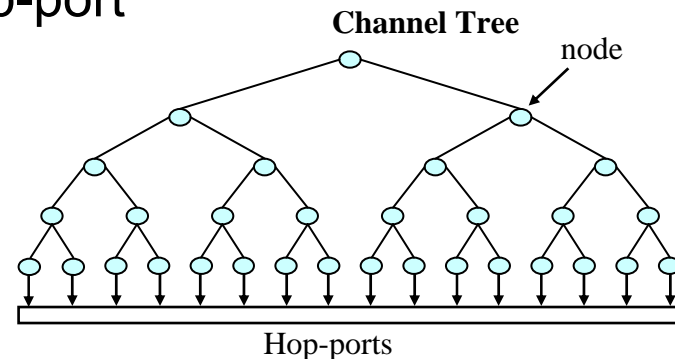

- Assignments can be “sticky” or “non-sticky”
 - Non-sticky assignments expire after one packet, while sticky assignments persist until supplemented, decremented, deassigned or packet loss
 - Sticky assignments reduce signaling requirements when multiple users are scheduled simultaneously
 - Also can be used to eliminate request latency for RL assignments
 - Low-power erasure sequence transmissions used as a keep-alive indication for sticky assignments when no packet is available to send

Forward Link Hopping

- Symbol rate hopping
 - Assignment
 - Set of tones scattered across entire bandwidth
 - Hop permutation maps assigned hop ports to frequency
 - Permutation changes every two OFDM symbols (supports STTD)
 - Independent hopping across sectors
 - Channel and interference estimation
 - Broadband common pilot
- Block hopping
 - Assignment
 - Set of tiles scattered across entire bandwidth; one tile → 8 contiguous OFDM symbols and 16 contiguous tones
 - Hop permutation maps assigned hop ports to tiles in frequency; fixed for duration of PHY Frame
 - Independent hopping across sectors
 - Channel and interference estimation
 - Localized channel and interference over every tile required
 - Dedicated (localized) pilot
 - Interference variance 'approximately constant' across a tile in a synchronized system

Forward Link: Symbol Rate Hopping

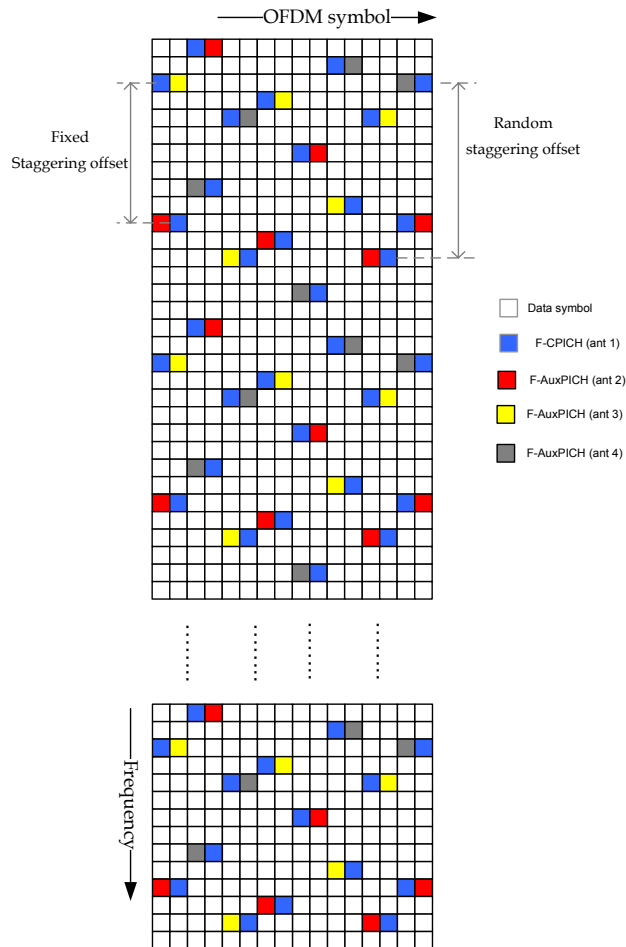

- Pilot structure
 - Flexible power and bandwidth overhead
 - Pilot tones equispaced across the carrier
 - Random offset for pilots every two OFDM symbols
 - SIMO support → Pilot channel transmitted on F-CPICH; two-level staggering for F-CPICH
 - MIMO support → auxiliary pilot channel
 - flexible multiplexing of antennas between F-CPICH and F-AuxPICH
- Channel estimation performance benefit
 - Due to a common broadband pilot

Forward Link: Block Hopping

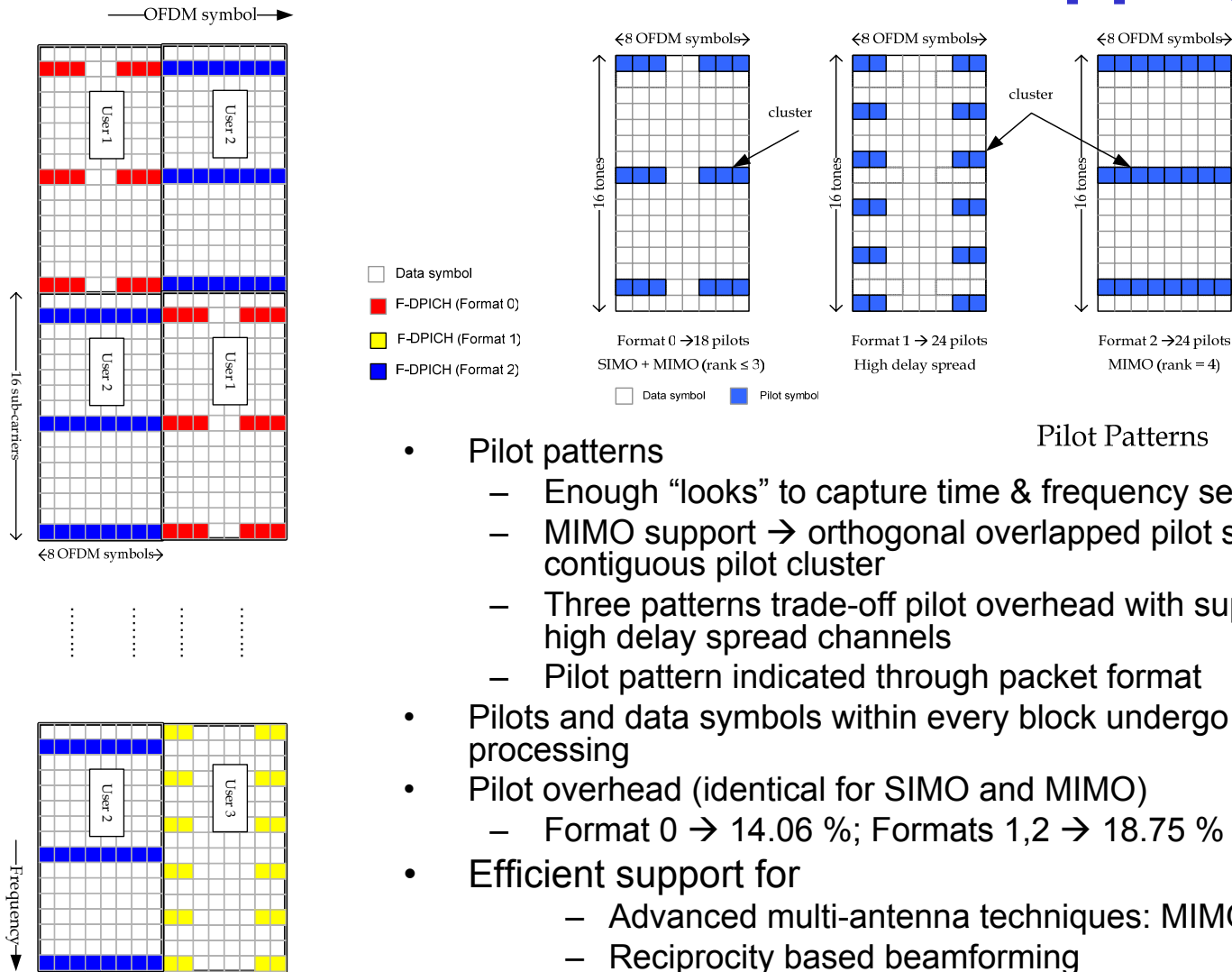

- Pilot patterns
 - Enough “looks” to capture time & frequency selectivity
 - MIMO support → orthogonal overlapped pilot sequences over each contiguous pilot cluster
 - Three patterns trade-off pilot overhead with support for MIMO and high delay spread channels
 - Pilot pattern indicated through packet format
- Pilots and data symbols within every block undergo the same transmit processing
- Pilot overhead (identical for SIMO and MIMO)
 - Format 0 → 14.06 %; Formats 1,2 → 18.75 %
- Efficient support for
 - Advanced multi-antenna techniques: MIMO, precoding, SDMA
 - Reciprocity based beamforming
 - Interference estimation and spatial interference nulling

Reverse Link: Block Hopping

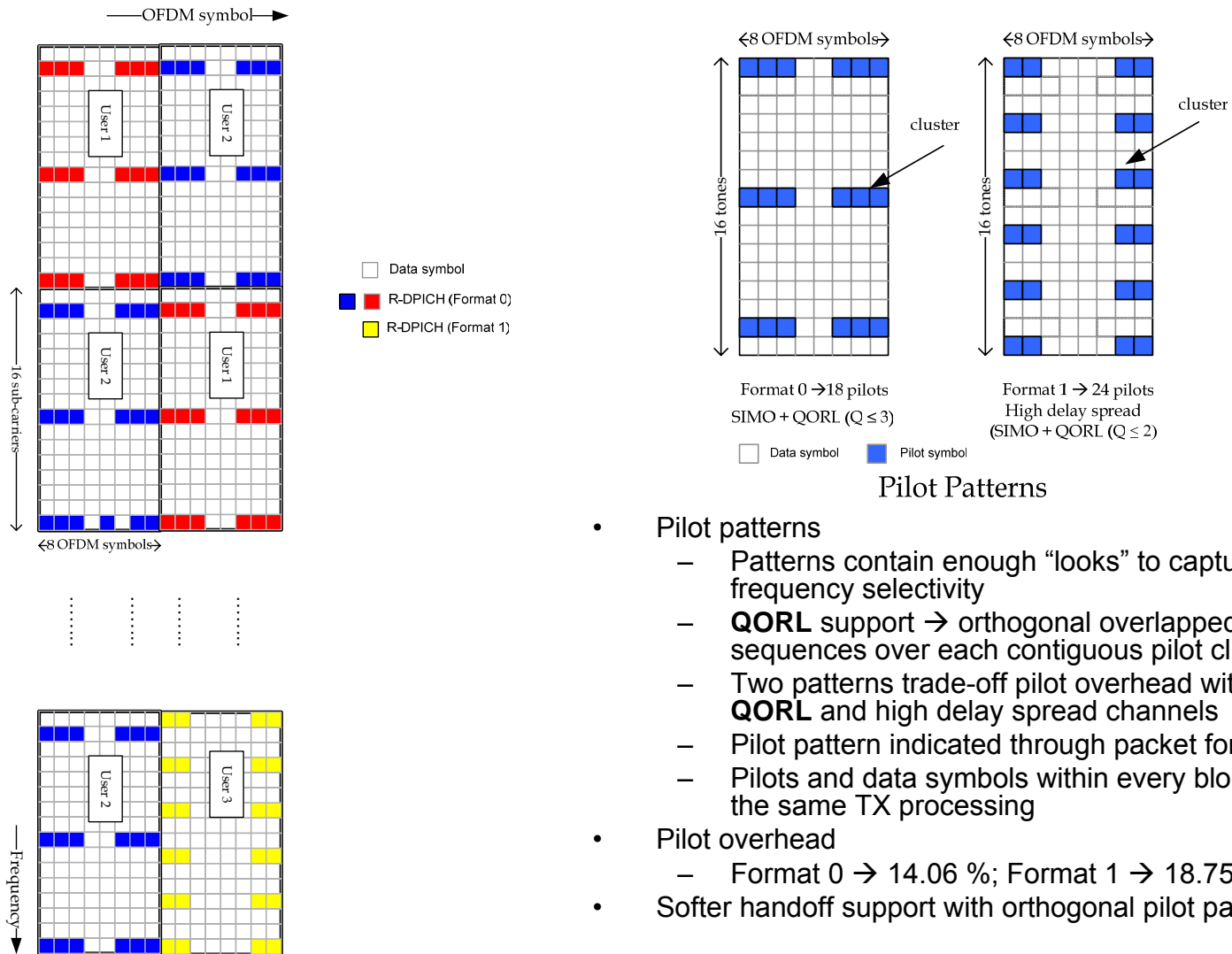

Forward Link Control Channels

- Resources managed using the FL Shared Signaling Channel (F-SSCH)
- F-SSCH design
 - FDM channel present in each PHY Frame
 - Variable F-SSCH overhead (For 5MHz, uses **10%** minimum bandwidth overhead, and can be incremented in **3.3%** steps)
 - 3 Segments
 - Resource management segment (“blocks”)
 - Acknowledgement segment (for ACKing RL traffic)
 - Power control segment (for controlling power of RL transmissions)
 - Unicast signaling enables overhead minimization particularly when targeting users with widely varying channel quality
 - Flexible overhead
 - Quasi-static bandwidth overhead
 - Flexible power overhead, adjusted every PHY Frame
 - Allows the system to tailor the overhead required for signaling for a variety of usage scenarios
 - No power overhead wasted when signaling needs change rapidly

F-SSCH: Resource Management Segment

- Carries a set of encoded and CRC protected blocks for assignments
- (F/R)LAB = Forward/Reverse Link Assignment Block
 - Sends assignment to a user, indicating the physical resources assigned (subcarriers) and the modulation/coding/pilot structure for use
 - Both “sticky” and “non-sticky” assignments supported
 - Supplemental assignments supported
- Access Grant Block
 - Transmitted in response to (and scrambled by) a detected access sequence
 - Provides a user with fine RL timing, a MACID to identify the user, and an initial channel assignment
- MIMO Assignment Blocks
 - Assign resources to MIMO users
 - Supports single codeword MIMO assignments providing PF and the number of layers to transmit
 - Support multi-codeword MIMO assignments: provides independent PF per codeword

F-SSCH: ACK & Power Control Segments

- Acknowledgement Segment
 - Carries ACKs in response to RL traffic
 - ACKs channelized based on RL channel tree, with an ACK channel provided for each minimum sized channel available
 - ACKs are encoded over a number of modulation symbols that are placed at different frequencies to provide channel and interference diversity
- Power Control Segment
 - Carries commands for closed loop control of reverse link control channel transmit power
 - Control rate of ~180 Hz

Reverse Link Control Channels (I)

R-CQICH

- ✓ reports FL channel quality in various transmission modes
- ✓ indicates FL handoff request
- ✓ $\geq 5.5\text{ms}$ report rate
 - *Control mode:*
 - signals FL channel quality (**4 bits**) for control and SISO traffic across the band
 - signals desired FL serving sector indicator to request FL handoff
 - *Single codeword MIMO:*
 - signals FL channel quality (**5 bits**) and rank for single codeword MIMO
 - *Multi codeword MIMO:*
 - occupies two R-CQICH instances
 - signals channel quality (**4 bits**) for each of four MIMO layers (=0 for unused layers)

R-REQCH

- ✓ indicates buffer level
- ✓ indicates maximum number of tones supported with nominal power density
- ✓ indicates RL handoff request
- ✓ $\geq 5.5\text{ms}$ delay

Reverse Link Control Channels (II)

R-SFCH

- ✓ enables sub-band scheduling and subband specific channel quality reports
 - indicates reported subband index
 - indicates subband channel channels quality including the anticipated TX/RX processing: subband scheduling gain, precoding, ...
- ✓ $\geq 5.5\text{ms}$ report interval

R-BFCH

- ✓ enables pre-coding and space division multiple access (SDMA)
- ✓ is part of CDMA control segment
 - indicates precoding index of the preferred precoding matrix
 - indicates required reduction in channel quality value if SDMA is used
- ✓ $\geq 5.5\text{ms}$ report interval

R-PICH

- ✓ broadband pilot channel to support channel-sensitive transmissions

R-ACH

- ✓ access preamble for initial access and access based handoff
- ✓ access latency with preamble power ramping: 99% tail within 22ms

CDMA control segment

- CDMA control segment \Rightarrow statistical multiplexing of various control channels
 - ✚ flexible load control by changing persistence of different channels
 - ✚ overhead reduction for access channel
 - ✚ broadband pilot to support subband scheduling and forward link beamforming
 - ✚ fast cell switching through handoff signaling
- Control segment spans a number of contiguous subbands over one RL interlace
 - ✚ minimum assignment of one subband (128 tones minus guard over 6 interlaces = 1/24 overhead in 5MHz)
 - ✚ scalable in units of subbands (1/24 granularity in 5MHz)
- Control segment hopping in time
 - ✚ R-CQICH provides power control reference across the entire bandwidth
 - ✚ R-CQICH and R-PICH provide broadband pilot that covers all the bandwidth over time

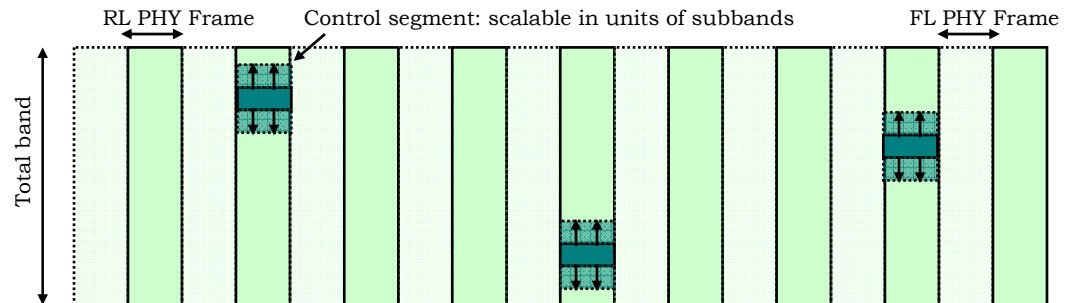

Modulation

- ✚ all channels of the control segment use Walsh codes (up to 1024)
- ✚ sector specific and, when applicable, MACID specific scrambling
- ✚ Initial access:
 - set of 1024 Walsh sequences (sector scrambling) partitioned according to F-CPICH strength and buffer level
 - AT chooses a sequence randomly from the appropriate partition

R-ACKCH channel

- Used to acknowledge FL H-ARQ transmissions
- Present on every RL interlace, linked to the corresponding FL interlace
- Channel based R-ACKCH
 - every base node of the channel tree maps to a 1-bit R-ACH
 - multi-codeword MIMO assignment spans number of nodes \geq number of layers

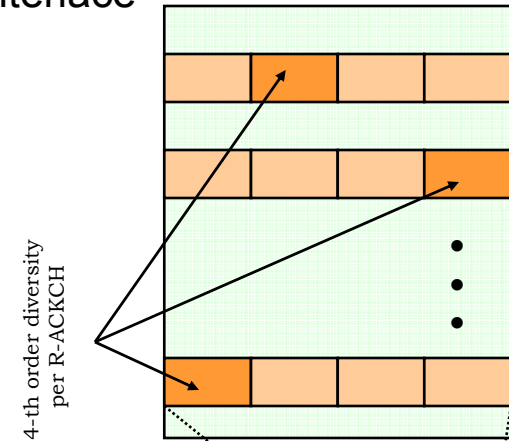
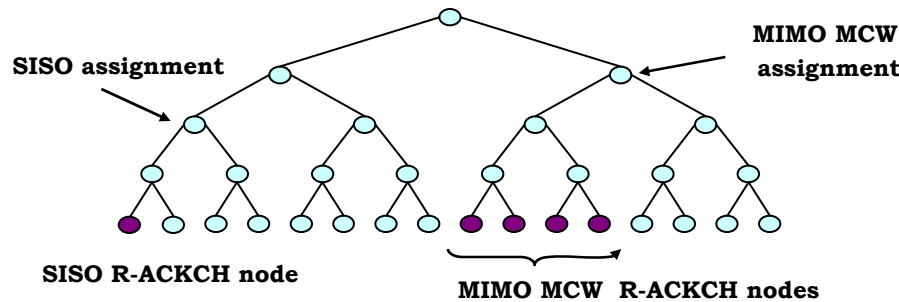

- Channelization & modulation
 - each R-ACKCH bit duplicated on multiple time-frequency tiles at least 4-th order diversity
 - orthogonal code multiplexing of different R-ACKCH bits allows for accurate interference estimation with extra code dimensions
 - improves link budget
 - ON/OFF keying
 - takes advantage of frequent NACK caused by H-ARQ
 - prevents ACK errors in some cases of assignment errors

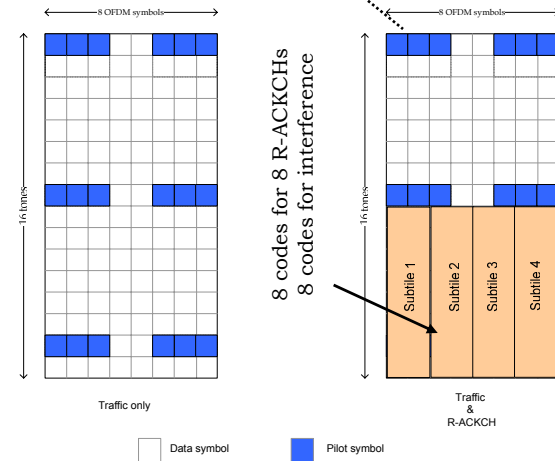

- Overhead
 - 8 dimensions per R-ACKCH, 128 dimensions per base node \rightarrow 1/16 RL bandwidth

Coding and Modulation

- Rate 1/3 convolutional code for block lengths ≤ 128
- Rate 1/5 turbo code for block lengths > 128
- Code is punctured or repeated to achieve desired code rate.
- Synchronous HARQ on both links.
- Channel interleaver
 - Based on bit-reversal.
 - Provides almost-regular puncture patterns and good interleaver distance properties at all code rates.
- Packet formats
 - Support the following modulation formats
 - FL: QPSK, 8PSK, 16QAM, 64QAM
 - RL: QPSK, 8PSK, 16QAM
 - Support a wide range of spectral efficiencies.
- Modulation step-down
 - At high spectral efficiencies, later HARQ transmissions use lower order modulations
 - this avoids repetition of coded bits
 - Gains up to 1dB for later transmissions

Forward Link Packet Formats

FL packet formats – SISO mode

Packet Format Index	Spectral efficiency on 1 st transmission	Max number of transmissions	Modulation order for each transmission					
			1	2	3	4	5	6
0	0.2	6	2	2	2	2	2	2
1	0.5	6	2	2	2	2	2	2
2	1.0	6	2	2	2	2	2	2
3	1.5	6	3	2	2	2	2	2
4	2.0	6	4	3	3	3	3	3
5	2.5	6	6	4	4	4	4	4
6	3.0	6	6	4	4	4	4	4
7	4.0	6	6	6	4	4	4	4
8	5.0	6	6	6	4	4	4	4
9	6.0	6	6	6	4	4	4	4
10	7.0	6	6	6	4	4	4	4
11	8.0	6	6	6	6	4	4	4
12	9.0	6	6	6	6	4	4	4
13	10.0	6	6	6	6	6	4	4
14	11.0	6	6	6	6	6	4	4
15	NULL							

- * Packet formats 10 - 15 are non-decodable at the 1st transmission: allow for high spectral efficiency at target termination

Reverse Link Packet Formats

RL packet formats

Packet format index	Spectral efficiency on 1 st transmission	Max number of transmissions	Modulation order for each transmission					
			1	2	3	4	5	6
0	0.25	6	2	2	2	2	2	2
1	0.50	6	2	2	2	2	2	2
2	1.0	6	2	2	2	2	2	2
3	1.5	6	3	2	2	2	2	2
4	2.0	6	3	3	2	2	2	2
5	2.67	6	4	4	3	3	3	3
6	4.0	6	4	4	3	3	3	3
7	6.0	6	4	4	4	3	3	3
8	8.0	6	4	4	4	4	4	3

- * Packet formats 7, 8 are non-decodable at the 1st transmission: allow for high spectral efficiency at target termination

RL Power Control

- **RL Control Channel Power Control**
 - Fast closed loop power control is used to set the transmit power levels on the reverse link control channels that are transmitted periodically
 - R-CQICH erasure indication from the RL serving sector is interpreted as up/down power control command by the AT
 - By setting the up/down step sizes, any target R-CQICH erasure can be achieved

- **RL Traffic Channel Power Control**
 - The traffic channel power level is set at an offset relative to the control channel power level
 - This offset is adjusted based on interference indications received from neighbouring sectors.
 - Maximum traffic power offset limited by inter-carrier interference

RL Traffic Channel Power Control (I)

- Data is transmitted at Δ dB above control
 - $[\Delta_{\min}, \Delta_{\max}]$ range is chosen to satisfy ICI margin requirement
 - Users should transmit at highest Δ possible subject to inter-sector interference
- Each sector measures other sector interference and broadcasts a three-level indication over F-OSICH
- AT adjusts its Δ based on F-OSICH from nearby AP's
- Delta-based power control results in
 - high Δ for strong users
 - low Δ for weak users

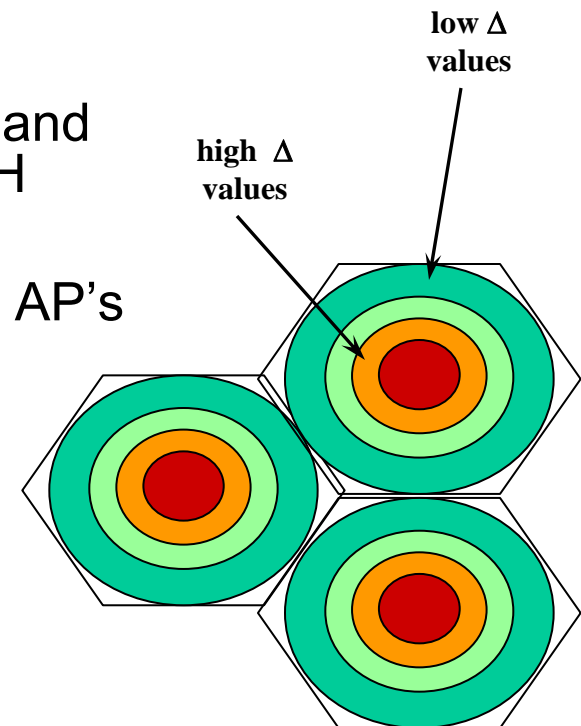

RL Traffic Channel Power Control (II)

- Explicit interference control leads to tight interference tail distribution
- Delta-based power control naturally shapes PSD of users that cause high and low interference while centralized scheduling achieves the desired fairness/capacity tradeoff

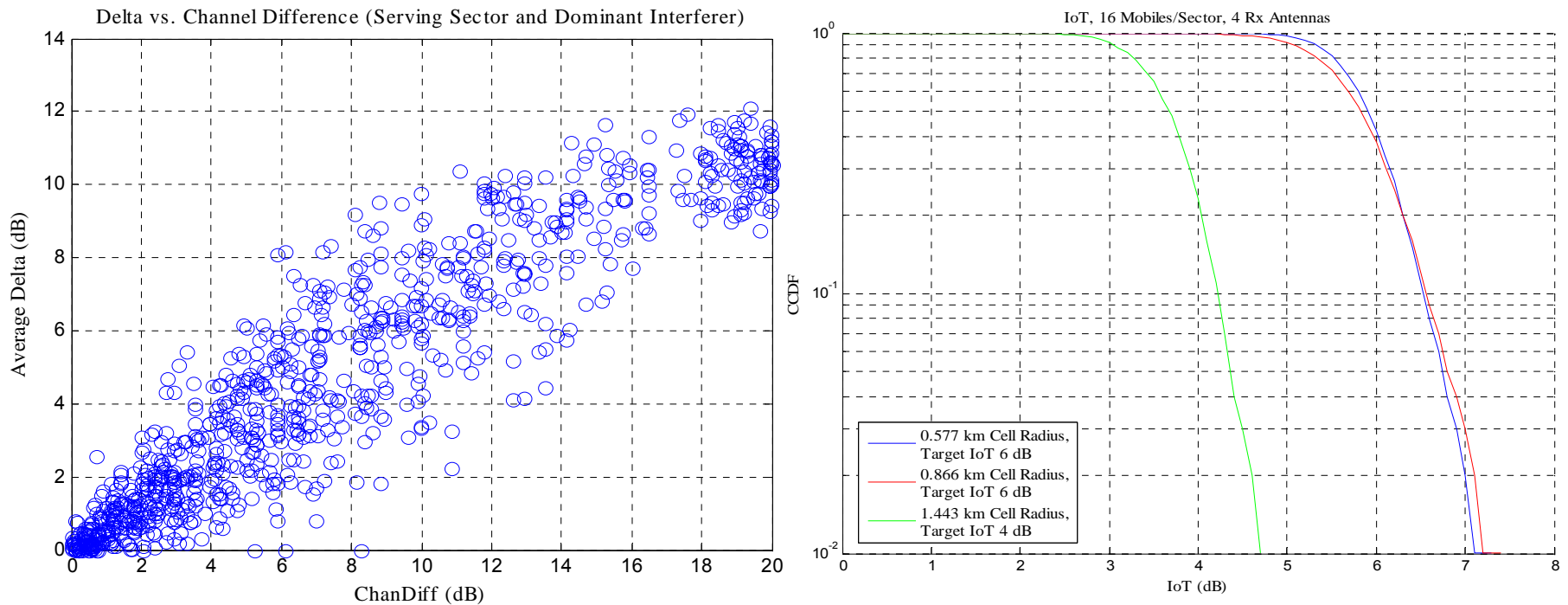

L1/L2 Handoff (I)

- AT constantly monitors pilots and R-CQICH erasure indicators on a set of sectors
- This enables Fast Serving-sector Switching within this set
- Forward link and reverse link serving sectors need not be the same
- Select FL serving sector based on FL pilot measurements
- Select RL serving sector based on R-CQICH erasure indicators
- Handoff indication
 - AT indicates a desired FL serving sector using R-CQICH.
 - AT indicates a desired RL serving sector using R-REQCH.
- Handoff completion
 - Handoff completes when AT receives assignment from the new sector
- Average handoff delay can be as low as 8ms

Forward Link Handoff Call Flow

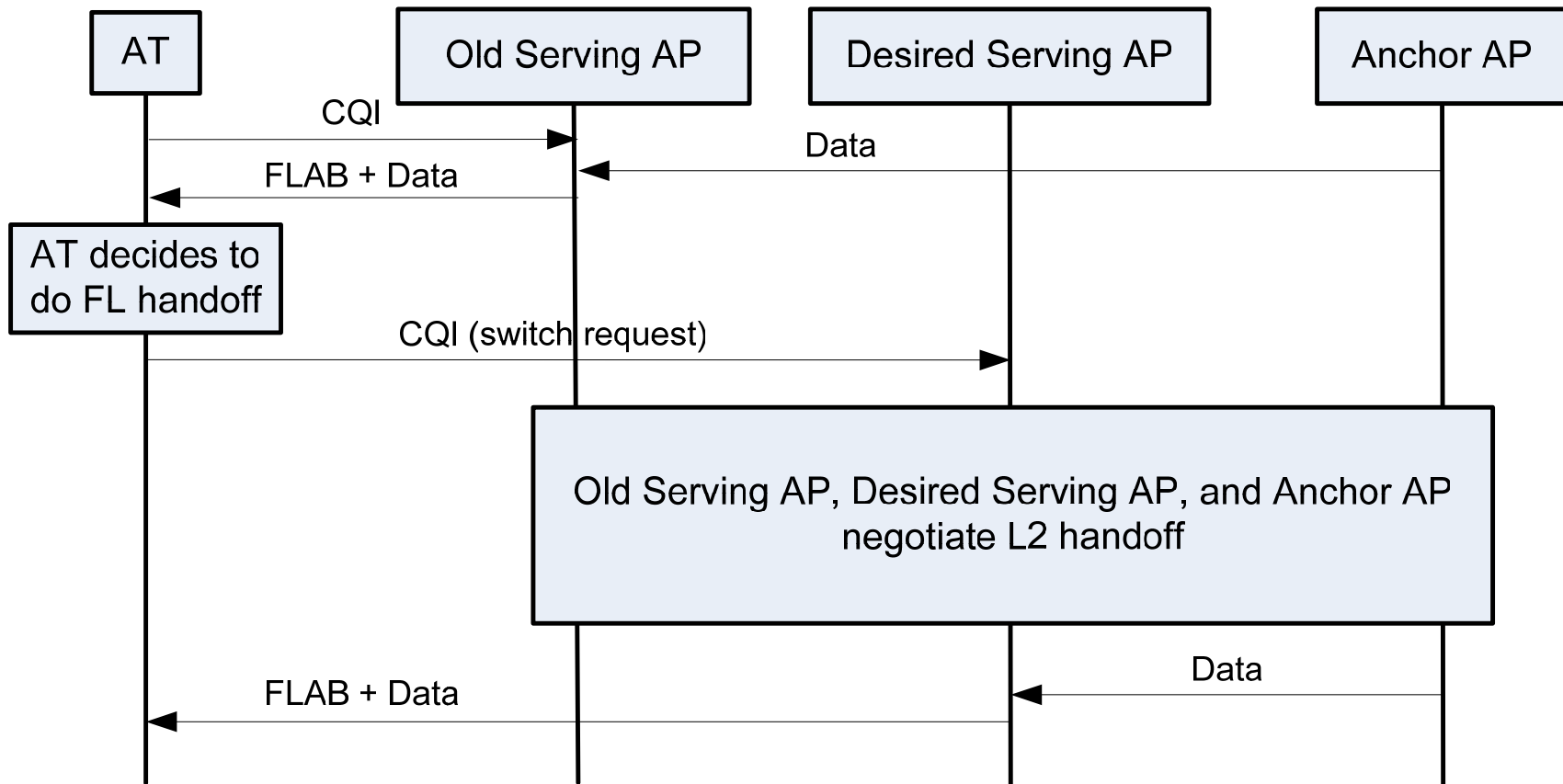

Reverse Link Handoff Call Flow

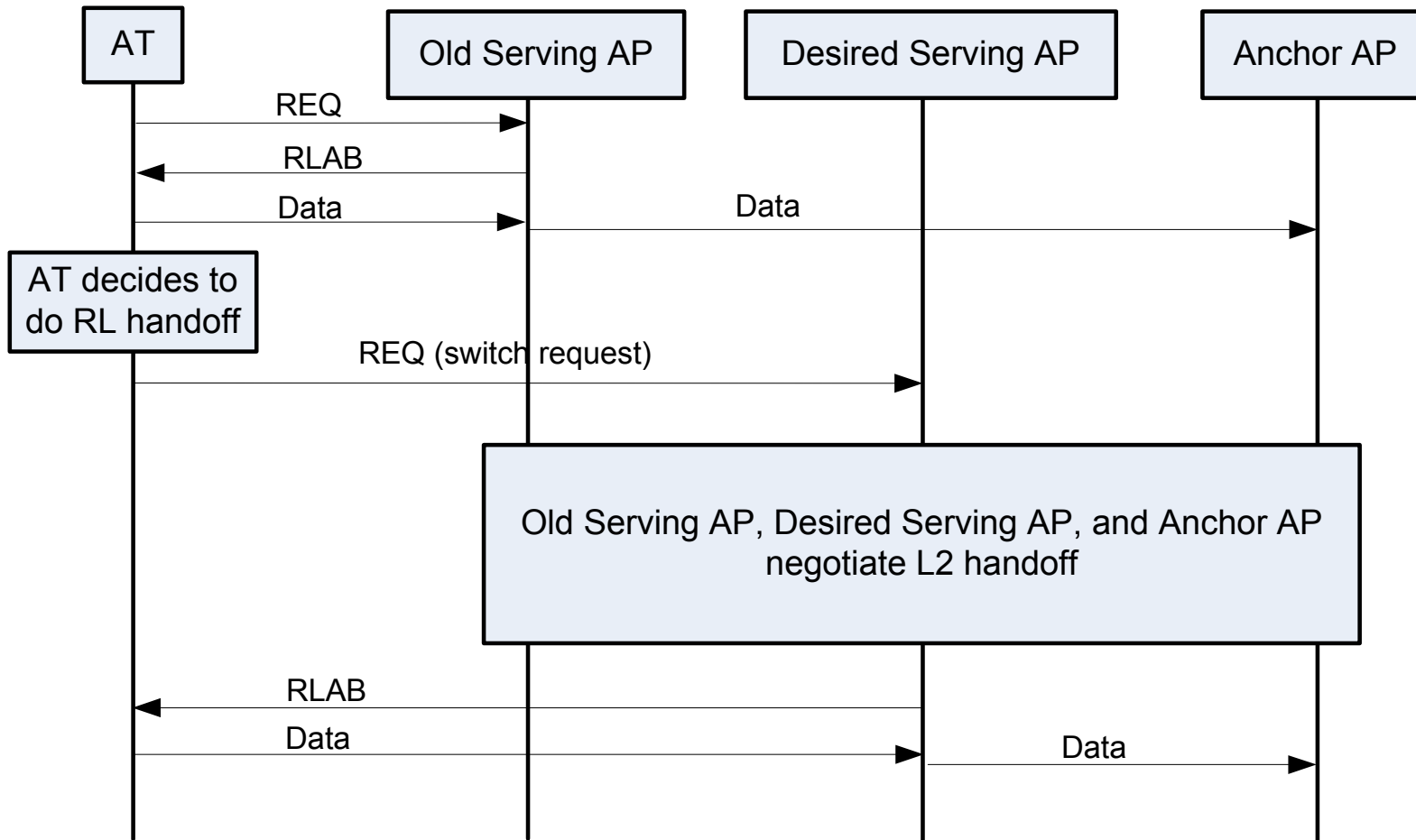

Inter Frequency and Inter Radio Access Technology Handoff

- Inter-Frequency Handoff
 - Active Set Management supports one or more Frequency Pilots
 - Advertised Neighbor List contains other Frequency Pilots
 - Tune-away mechanism to measure other Frequency Pilots

- Inter-RAT Handoff
 - AT driven
 - Handoff Policy at AT
 - Advertised Neighbor List contains other technology information
 - Tune-away mechanism to measure other RAT Pilots

- Receiving Pages for other RAT
 - Tune-away mechanism to listen for other RAT pages
 - Cross registration/paging
 - Inter RAT Protocol
 - InterRATBlob message
 - Requires core-network co-operation

Multi-Carrier Mode - I

- Special mode to support ATs capable of demodulating only 5MHz of bandwidth in a wideband deployment (eg 20MHz)
 - 5MHz demodulation constraint can be baseband (e.g. FFT size) as well as RF front-end (e.g. receive filtering, A/D sampling rate)
 - Enables low-cost, low-power terminals
 - Support high peak-rates for ATs that are capable of demodulating larger bandwidths
- The 20 MHz (2048 point) FFT is divided into four 5MHz “carriers” (512 point FFT)
 - Guard tones are allocated at the edge of each carrier
 - Control channels are present in each carrier
 - Assignment, ACK and power control on the FL
 - CDMA control segment and ACK channel on the RL
 - Acquisition preambles and overhead channels are also present in each carrier

Multi-Carrier Mode - II

- The configuration of each carrier is independent
 - Power control runs independently on each carrier
 - Control channels are sized independently on each carrier
 - Network can configure the different carriers to meet different objectives (support link-budget constrained users, frequency reuse within and across carriers etc)
- Support very fast switching among the different carriers
 - Switch is applicable at the next PHY Frame (sub ms switching)
- AT receives and transmits on the union of its assignments on all the carriers it is monitoring
 - Peak rate similar to that of a 20MHz system

Fractional Frequency Reuse

- Frequency reuse can be used as an interference management technique
 - Traditional frequency reuse schemes apply the same reuse factor to all users, which leads to capacity loss
 - Thermal limited users do not benefit from interference reduction
 - High C/I non-MIMO users do not benefit from additional interference reduction
- User selective frequency reuse can improve capacity and QoS if it is applied to users who are
 - With good C/I and bandwidth tradeoff (FL edge users and MIMO users)
 - Dominant interferers on RL
 - Link budget limited users on RL

Sector Coloring and Frequency Planning for FFR

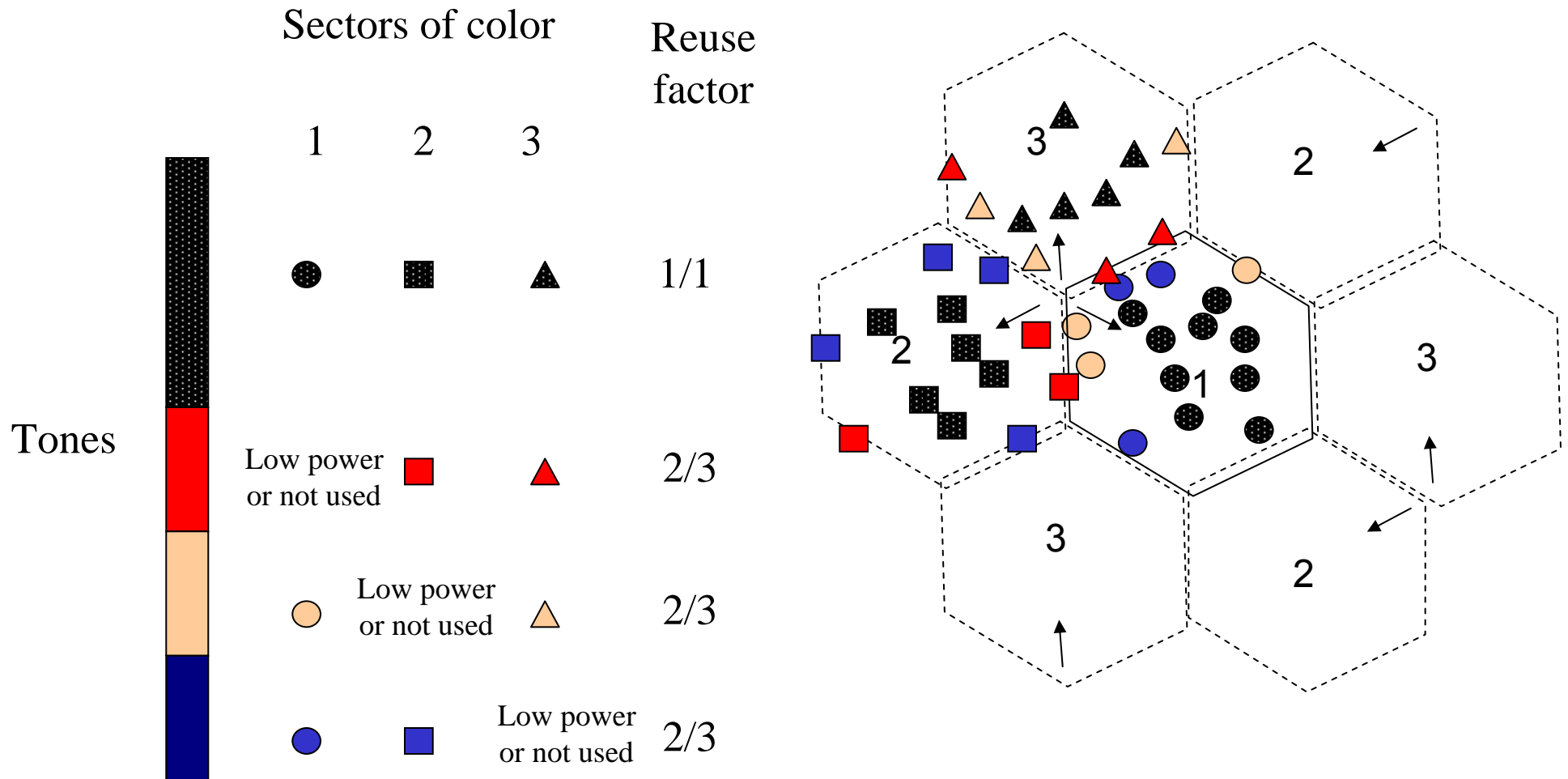

Potential capacity gain given good C/I and bandwidth tradeoff

Forward Link C/I with FFR

- Most significant SNR gain comes from “directional” 2/3 frequency reuse for users at the sector boundary
 - E.g., Users who are served by sector 1 and interfered by sector 2 can be allocated to subcarriers that are not used by sector 2

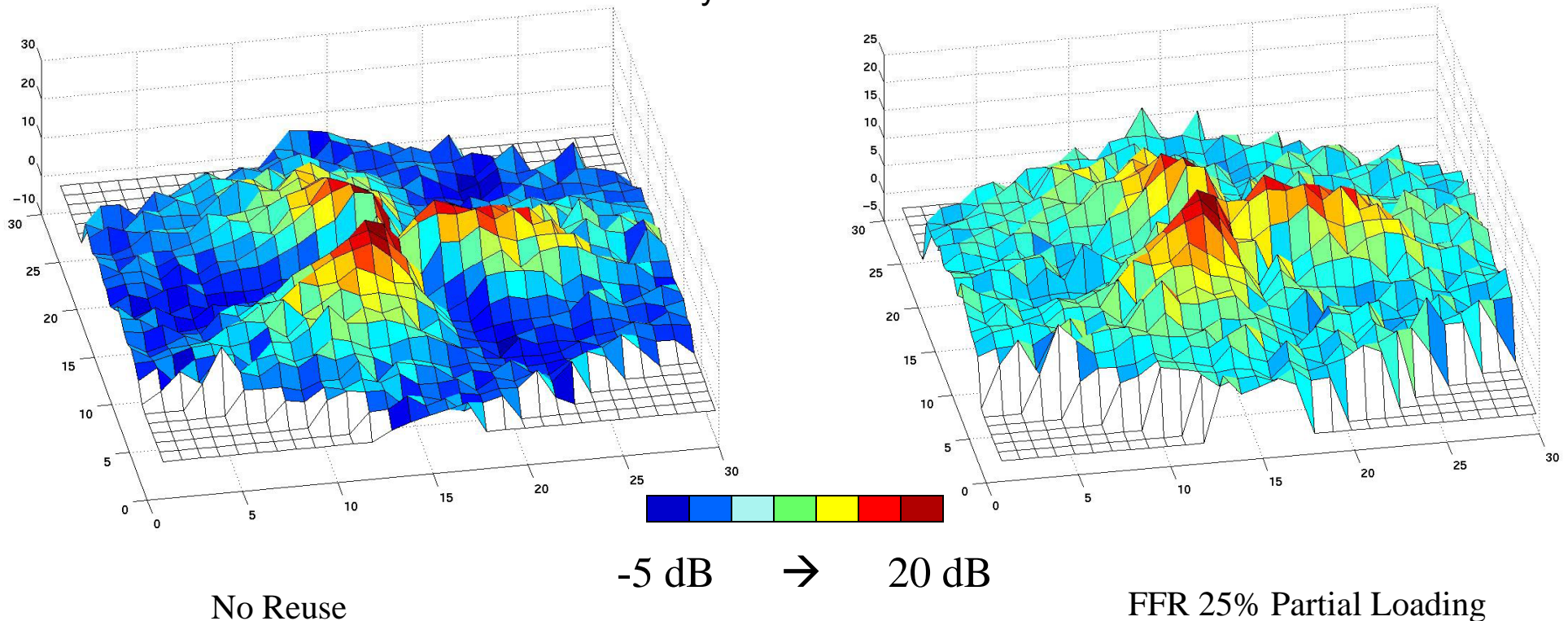

- Additional pilot reporting is used for reuse set management

Dynamic FFR

- Dynamic FFR enables packet-by-packet scheduling of resources with different frequency reuse factor based on reuse set specific CQI
- Frequency reuse specific CQI is obtained by combining “short term” control CQI and “long term” interference offset between reuse sets
 - Control CQI reporting could be as fast as 150 Hz
 - A message containing the average C/I for each subband is reported at much lower frequency

FL and RL subband scheduling

- ✓ Multi-user diversity gains through frequency sensitive scheduling
 - improves fairness through SNR gains to weak users
 - enables multi-user diversity gains for latency sensitive users
- ✓ Design supports two hopping modes
 - diversity mode with global hopping across the band
 - subband mode with localized hopping
- ✓ Total bandwidth sub-divided into subbands
 - nominal subband size 1.25MHz (128 contiguous tones)

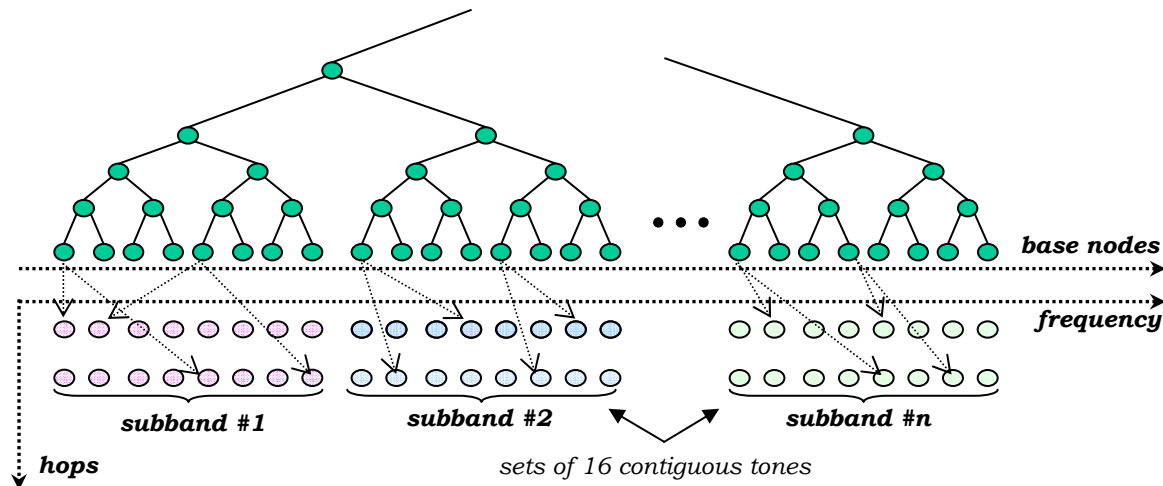

- base nodes hop over the entire subband
ensures interference diversity

Subband scheduling: reporting

- ✓ FL subband scheduling
 - ✓ flexible tradeoff between sub-band scheduling gains and reporting load
 - ↘ RL control channel to report subband information
 - ↘ allow for variable reporting interval
 - average reporting interval defined by AN
 - ↘ allow for flexible report size
 - report subband index and optionally subband channel quality, mandated by AN
 - * RL broadband pilot (CDMA) enables FL subband channel quality assessment at AN due to FL/RL channel reciprocity in TDD
 - no need for RL control overhead

- ✓ RL subband scheduling
 - ↘ rate prediction & scheduling by AN
 - ↘ RL broadband pilot (CDMA) enables RL subband channel quality assessment at AN
 - can use RL CDMA control channels (mainly R-CQICH) as a pilot
 - can use dedicated RL CDMA pilot (R-PICH)

MIMO Design

- Complete OFDMA/MIMO design taking in consideration the following:
 - HARQ
 - Rate prediction
 - Channel estimation
 - Feedback overhead
 - Spatial correlation effects
 - MIMO complexity
 - Mobility
 - *Up to 120Km/hr and graceful degradation afterwards*
 - Simultaneously support both SISO and MIMO users

Design Philosophy

- **Definitions:**
 - Number of physical antennas M_t , and is fixed
 - Number of effective antennas $M_e \leq M_t$
 - Spatial multiplexing order (rank) $M \leq M_e$: The number of modulation symbols (a.k.a. layers) transmitted at a time
- The goal is to have a **flexible design** where the **data rate and rank** are **adapted** to channel conditions
- Two MIMO modes: **SCW & MCW**

Effective Antenna Signaling

- The M_t physical antennas are mapped to M_e effective antennas through Matrix multiplication
- Directions correspond to different columns of the matrix are called **effective antennas**
- SISO is transmitted from the **first effective antenna**
- MIMO is transmitted from **all effective antennas**
- If M layers are transmitted over M_e effective antennas, each layer is **cycled in the tone-space domain**
- Flexible to support any value of transmit antennas
 - Transmitting over the physical antennas is a special case

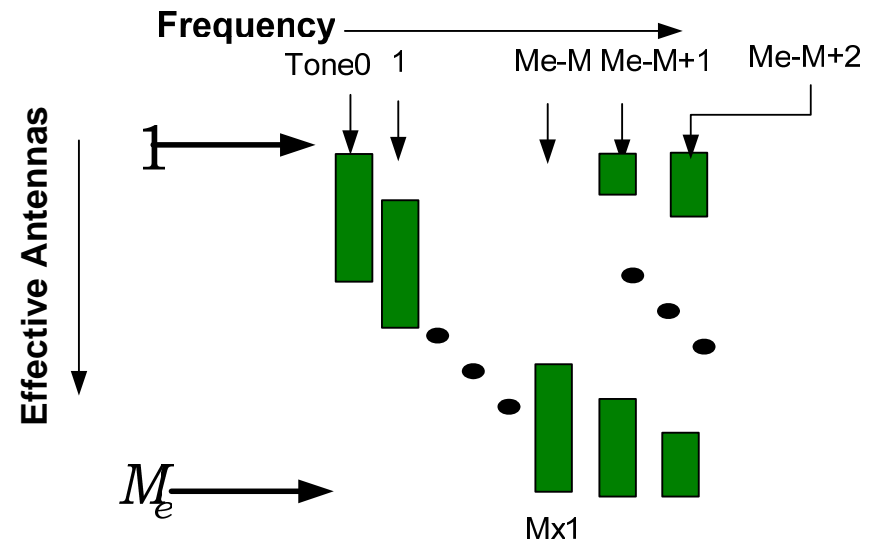
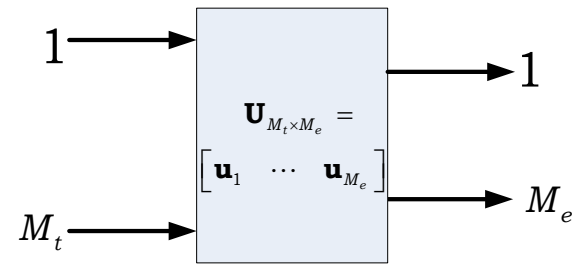

SCW Design

- Adapting the **rate** and **rank** to channel realizations
- One PF is transmitted with M modulation symbols transmitted at a time
- H-ARQ similar to SISO
- Receiver can employ a **linear MMSE** or more sophisticated detectors
- Low complexity if just linear MMSE is employed

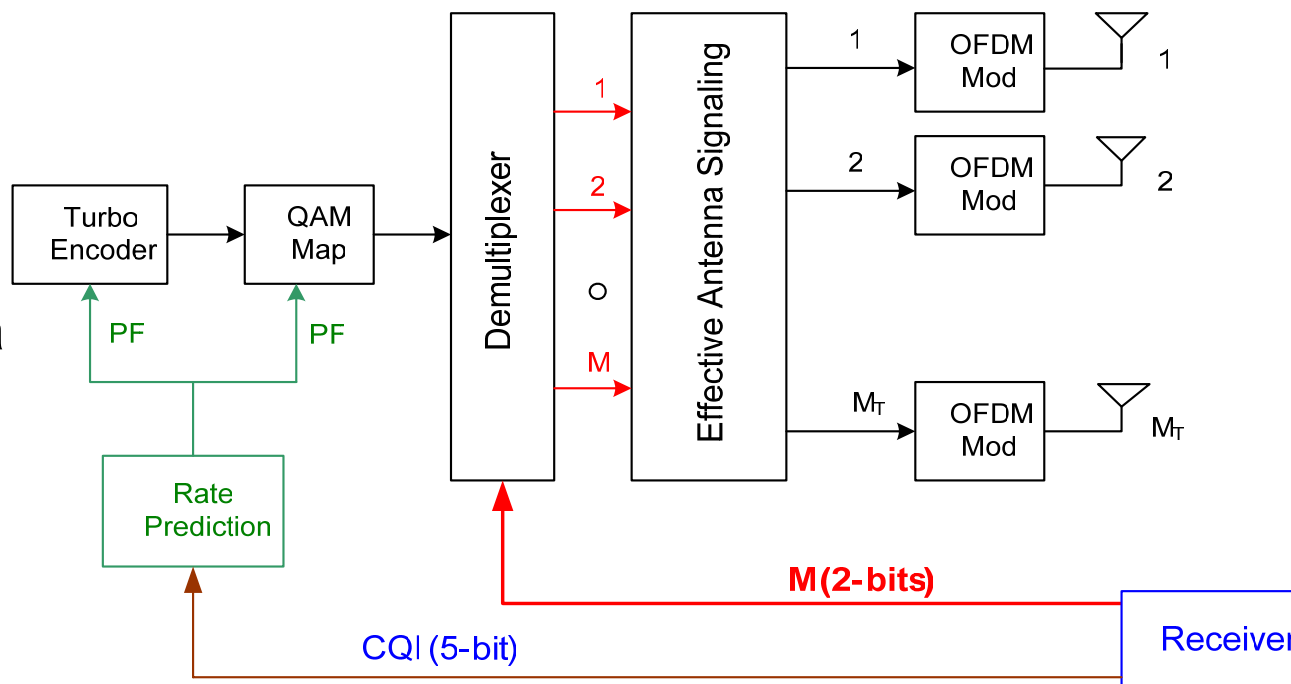

- Two main RL feedback channels are used:
 - **CQI**, preferred rank on the **R-CQICH** (SCW report)
 - **ACK-NACK** on the **R-ACKCH**

MCW Design

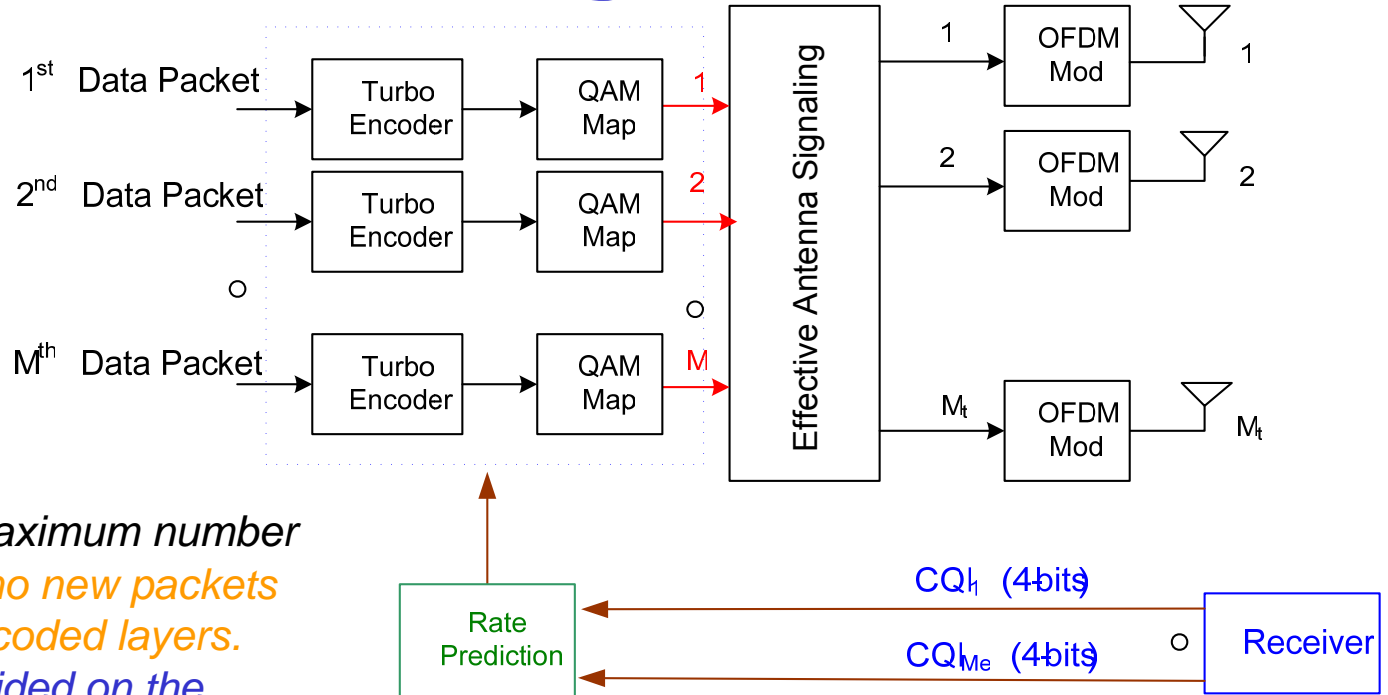

- CQI feedback for each layer, i.e rate prediction is done per layer
- M PFs are simultaneously transmitted
- SIC receiver is used to decouple the M layers
- BL-HARQ: Within the maximum number of HARQ transmissions, no new packets are transmitted on the decoded layers. Total power is equally divided on the outstanding layers

- Two main RL feedback channels are used:
 - CQI per layer on the R-CQICH (MCW report)
 - ACK-NACK on the R-ACKCH: one bit per layer

Compared to SCW/MMSE:

- more complex and memory demanding
- higher throughput and more tolerant to spatial correlation

Precoding & Space Division Multiple Access

- RL feedback information in combination with RL pilot may be used for FL beamforming
 - Beamforming gain to SIMO users
 - Eigenbeamforming gain to MIMO users
 - Space division multiple access (SDMA)
 - Multiple users scheduled on same time-frequency resource
 - Users overlapped using beams pre-defined in codebook
 - Increased system dimension; adaptive sectorization gain

Codebook design

- Codebook structure
 - several codebooks adapted to different scenarios, e.g., number of transmit antennas, propagation environment, etc.
- Codebook entry description
 - Each entry describes a linear spatial transmit processing to be applied at the AP
 - The entries support the following transmission modes
 - Diversity mode transmission
 - Beamforming to line of sight users
 - MIMO precoding
 - SDMA and MIMO-SDMA
 - If the entry is a matrix, the number of columns indicate maximum number of supportable layers
 - Rank feedback indicates number of columns to be used in the transmission

Signaling

- Pilot channel
 - Broadband common pilot channel (F-CPICH) for CQI computation
 - Pilots on all antennas
- CQI computation
 - Pilot channel enables space and frequency selective channel estimation
 - CQI computation per subband using codebook
 - CQI and codebook entry index fed back on reverse link control channels
- Feedback mechanism (R-CQICH, R-BFCH, R-SFCH)
 - R-CQICH → CQI for default mode (diversity mode transmission)
 - R-BFCH → Codebook entry index and differential SDMA CQI
 - R-SFCH → CQI captures precoding
 - Multiple feedback channels per user possible (frequency selectivity)
- Transmission
 - Transmission mode determined by the AP based on feedback from AT
 - User (and possibly frequency) selective precoding
 - Data and pilots processed identically → provides transparency and robustness

MAC support

- Requirements
 - Support for precoding with and without SDMA
 - Scalability with high granularity in resource allocation to modes
- Tree design
 - Channel tree contains multiple sub-trees
 - One sub-tree per SDMA cluster with one primary sub-tree
 - Identical hop pattern across sub-trees
- Scheduling
 - Any user scheduled on only one sub-tree
 - Users scheduled across different sub-trees overlap
 - Users scheduled within a sub-tree remain orthogonal

Beamforming

- Reciprocity
 - FL and RL transmissions on same frequency
 - Channel estimation at AP through reverse link pilots
 - Reverse link pilot on one transmit antenna
 - FL channel estimation for only one AT antenna possible
- Reverse link pilot
 - Pilot channel → R-PICH
 - Can use other channels (R-CQICH, R-DCH) if successfully decoded
 - Broadband channel estimation through CDMA control channel
- Transmission
 - Beamforming transmission based on RL channel estimates at AP
 - MIMO transmission → Pseudo-eigenbeamforming
 - First layer beamformed based on RL channel estimates
 - Remaining layers transmitted on the subspace orthogonal to first layer

Quasi Orthogonal Reverse Link

Rationale

- ✓ Non-orthogonal RL (CDMA): capacity scales linearly with the number of receive antennas
- ✓ Orthogonal RL: capacity scales logarithmically with the number of receive antennas

Design

- ✓ Superimposing ATs over time-frequency tiles
- ✓ Multiple antennas to suppress intra-sector interference space-frequency MMSE receiver

- ✓ Intra-sector interference diversity through random hopping
- ✓ Orthogonal pilots to improve channel estimation

QORL support in our design

- ✓ Define channel tree with sub-trees
 - ATs scheduled within one sub-tree are orthogonal
 - different sub-trees map to the same set of time-frequency resources

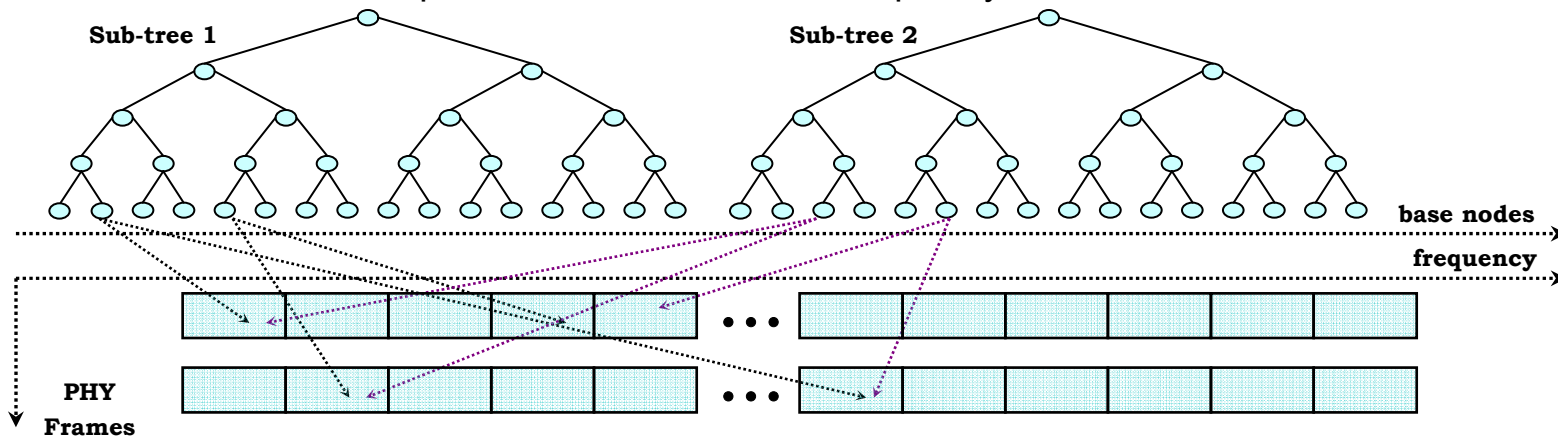

- ✓ Orthogonal pilots on different sub-trees
 - orthogonal (DFT) pilot codes over pilot clusters assigned to different sub-trees
 - supports QORL: different pilot codes assigned to different ATs
 - supports softer handoff: different pilot codes assigned to different sectors

