

# Architectural Thoughts – 25G Interconnect

---

BRAD BOOTH

MICROSOFT

# Supporters

---

You could have your name here...

Or here...

# Assumptions

---

Switch implementations likely to support multiple data rates; therefore likely to have all PCS and FEC versions available

Auto-negotiation is the available across all copper port types

- Optical ports will “force” the port type

10G/25G/40G NIC would have multi-lane capability due to 40G

- Could provide 4x10GBASE-R and n x25GBASE-R
- Likely to use QSFP28 module

10G/25G NIC could be a single-port device

- Implementations likely to use SFP28 module

OTN, if used, not likely to be between server-to-switch connection; only switch-to-switch

# Copper

---

# 802.3-2012 10G & 40G Backplane

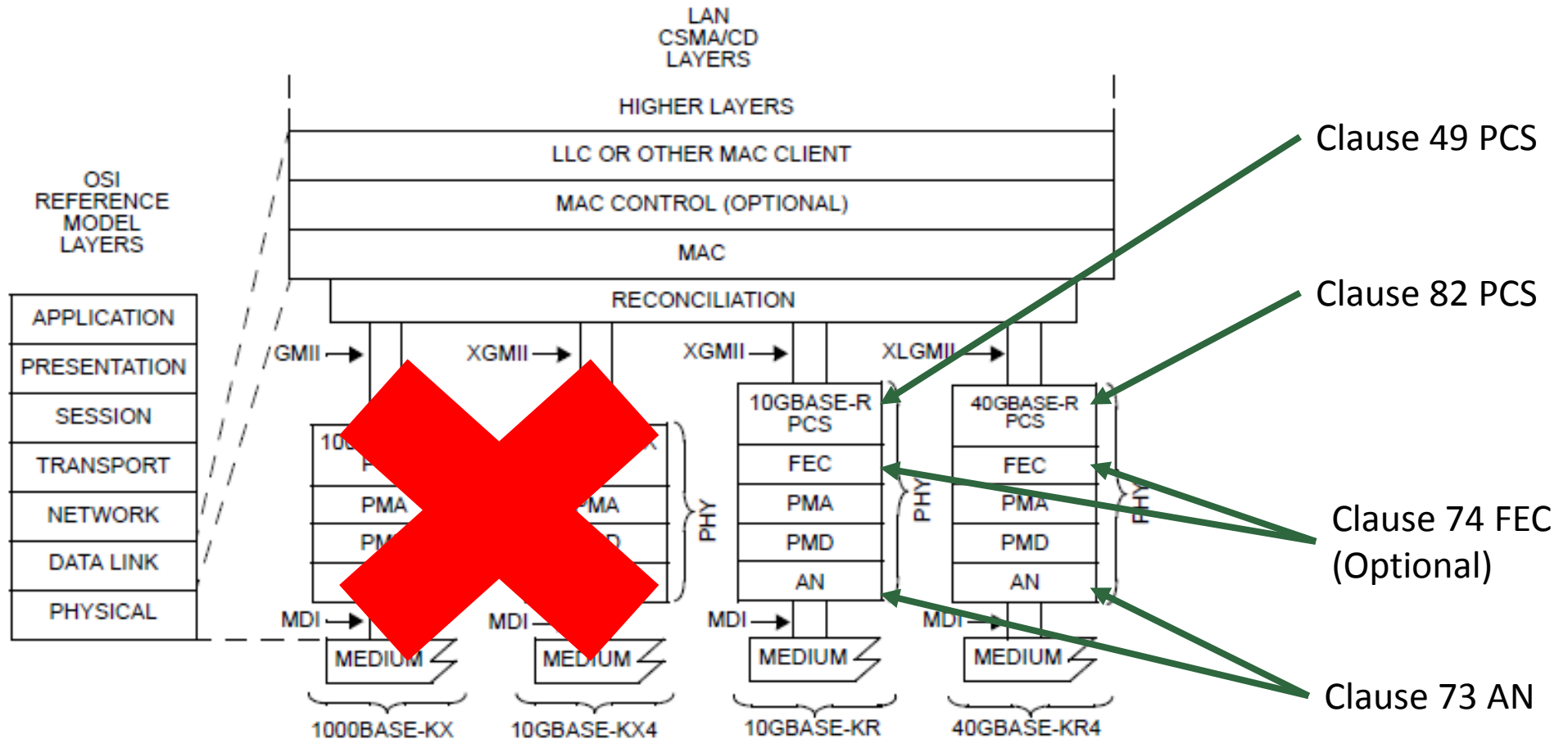

# 802.3-2012 40G Twinax

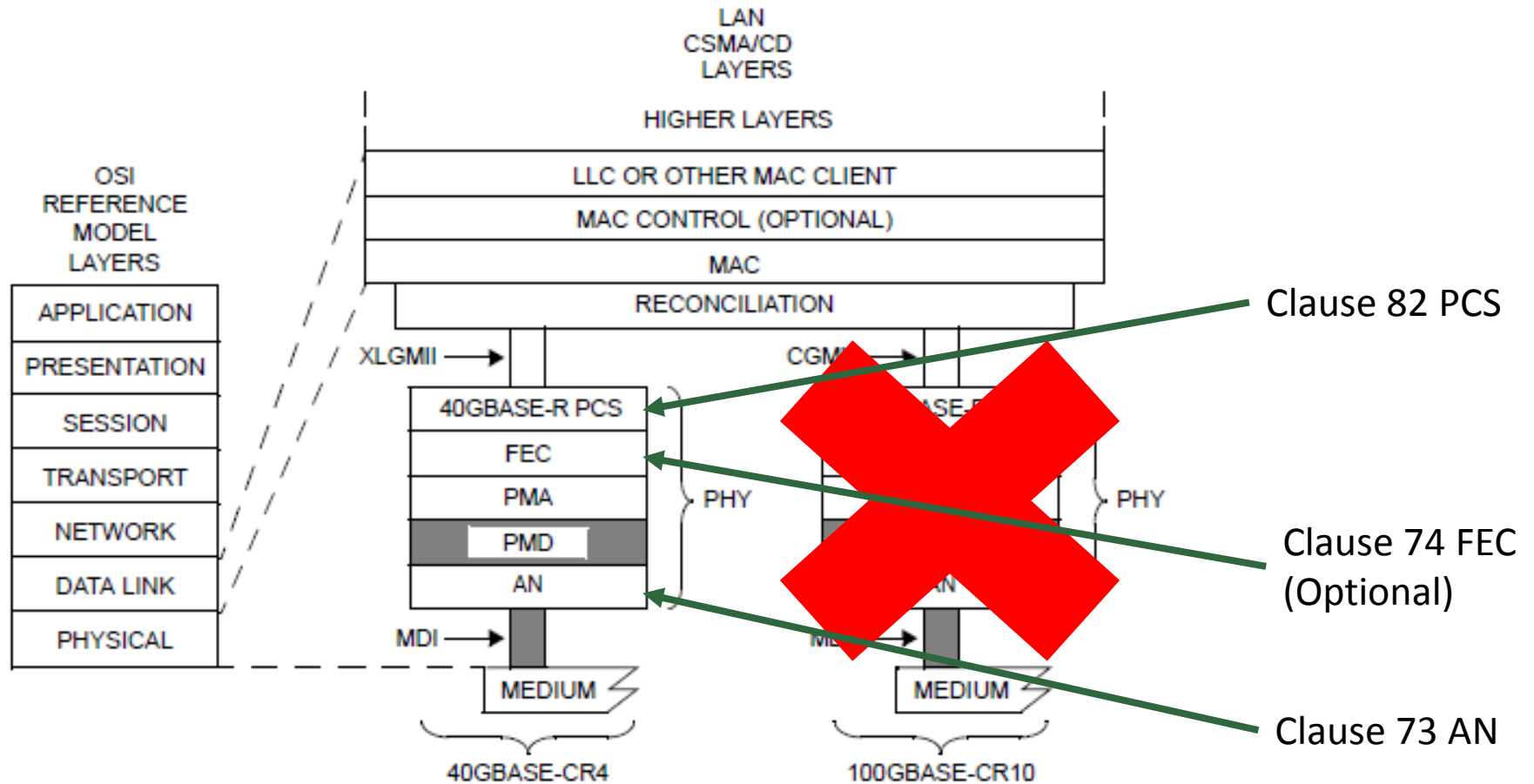

# 802.3bj-2014 100G Twinax & Backplane

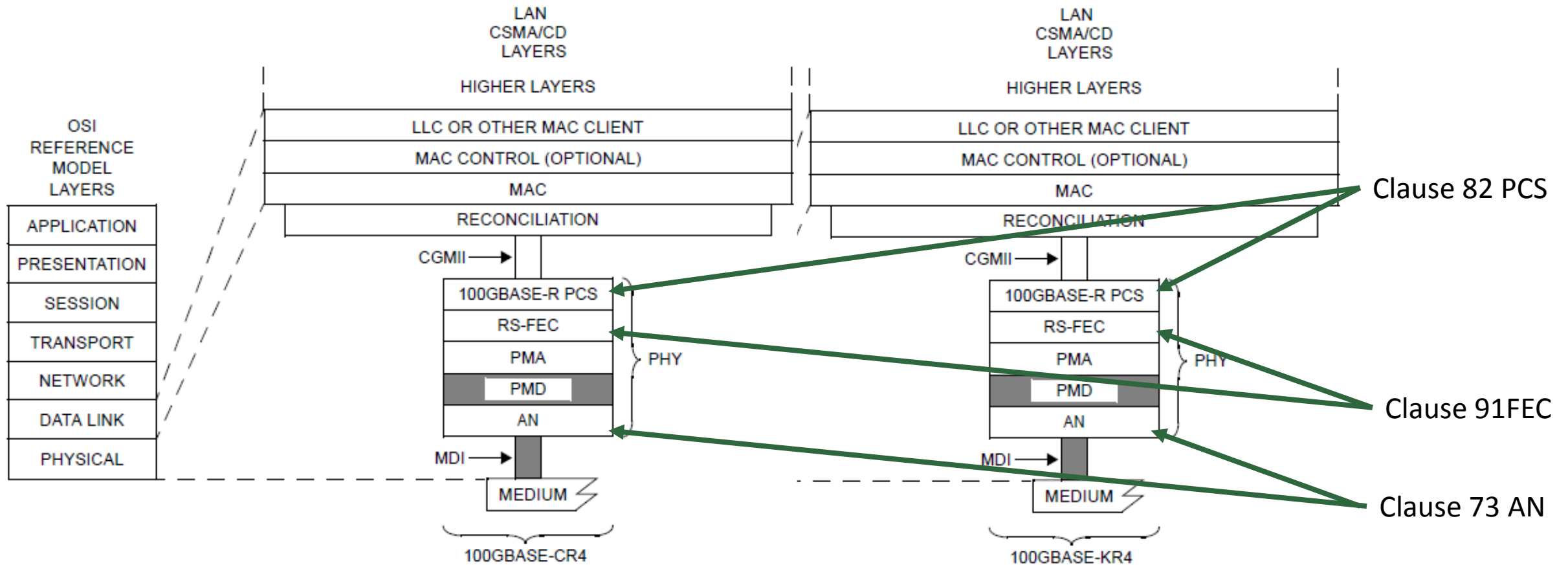

# Architectural Overview – What FEC and PCS for 25G Copper?

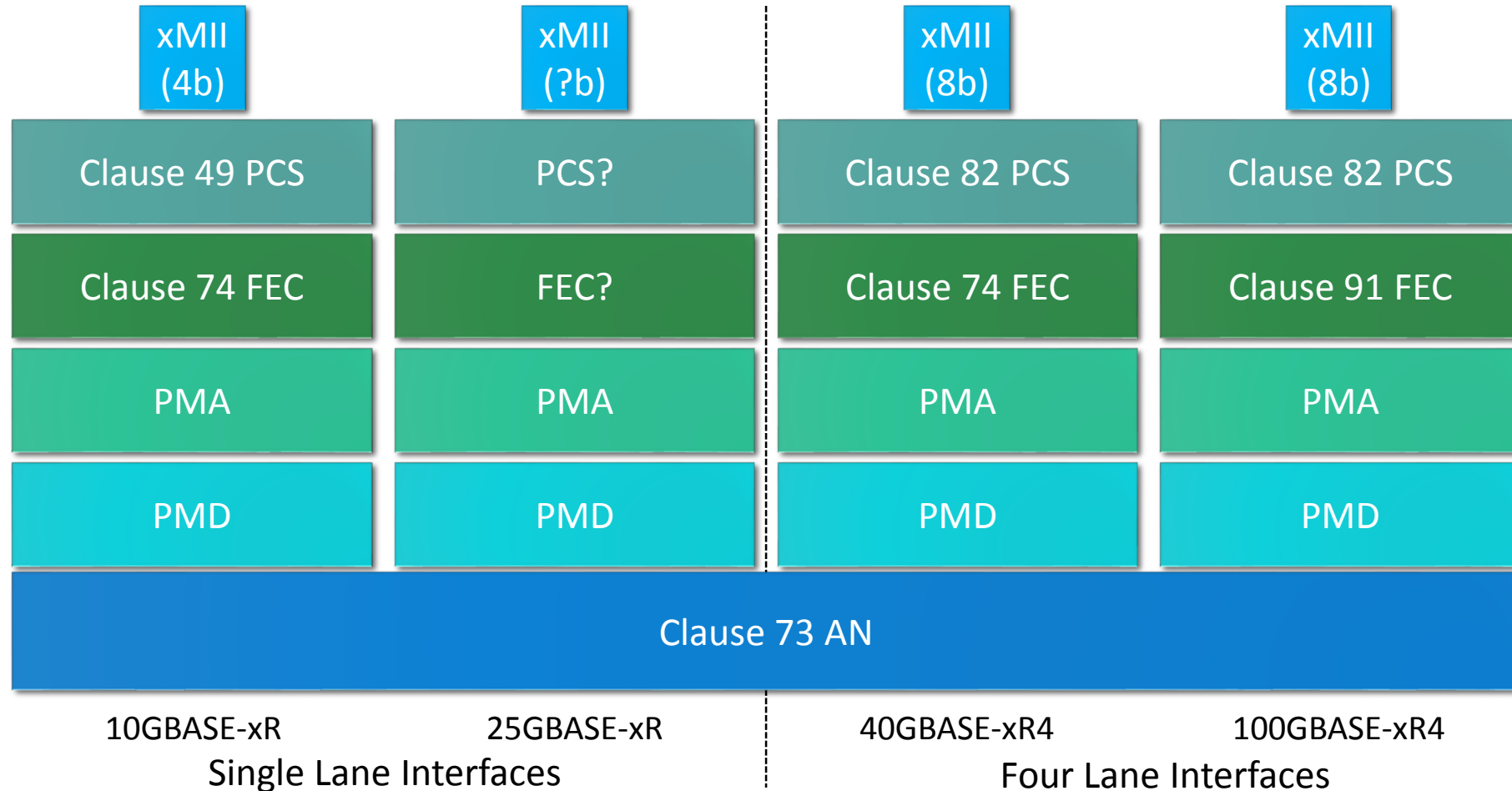



# 10G and 25G Network Interface Card

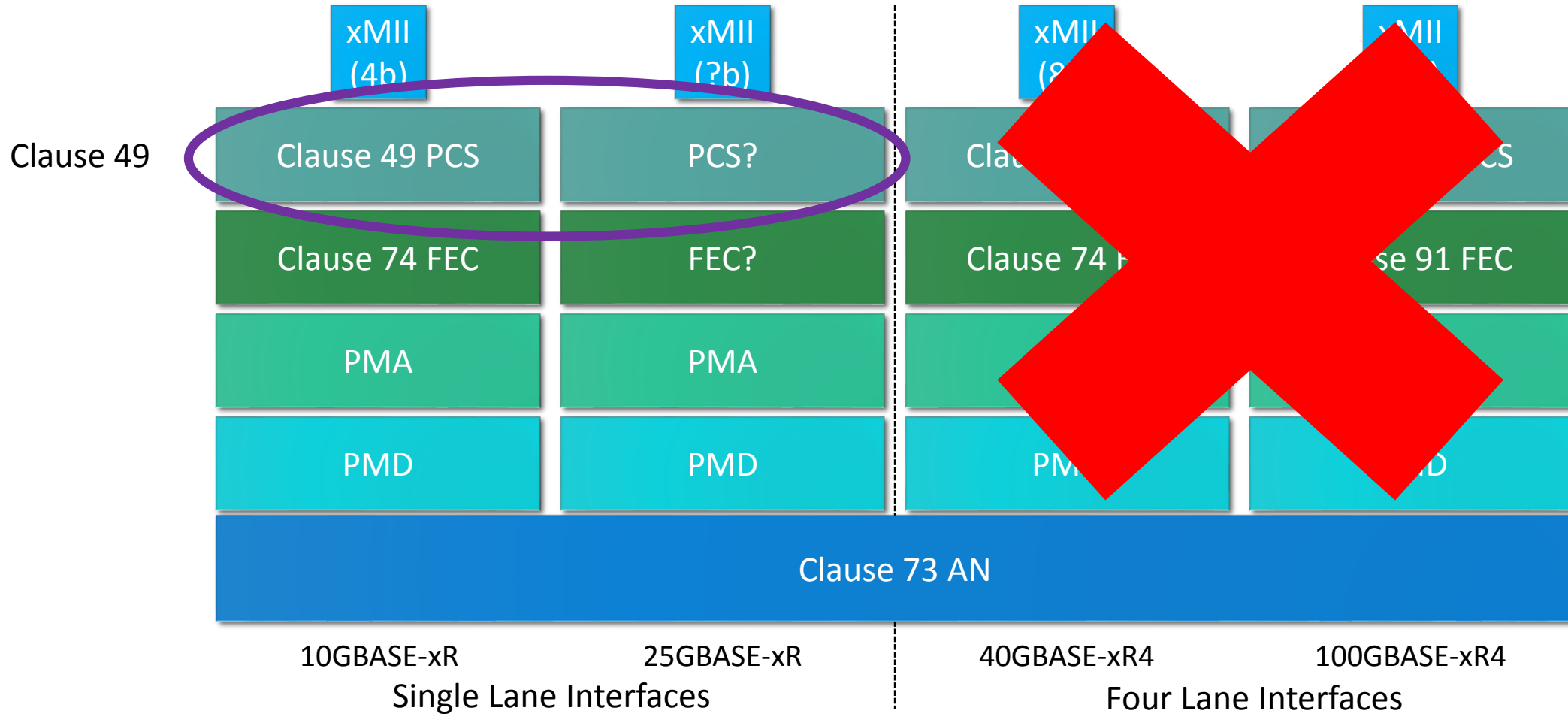

# 10G/25G/40G Network Interface Card

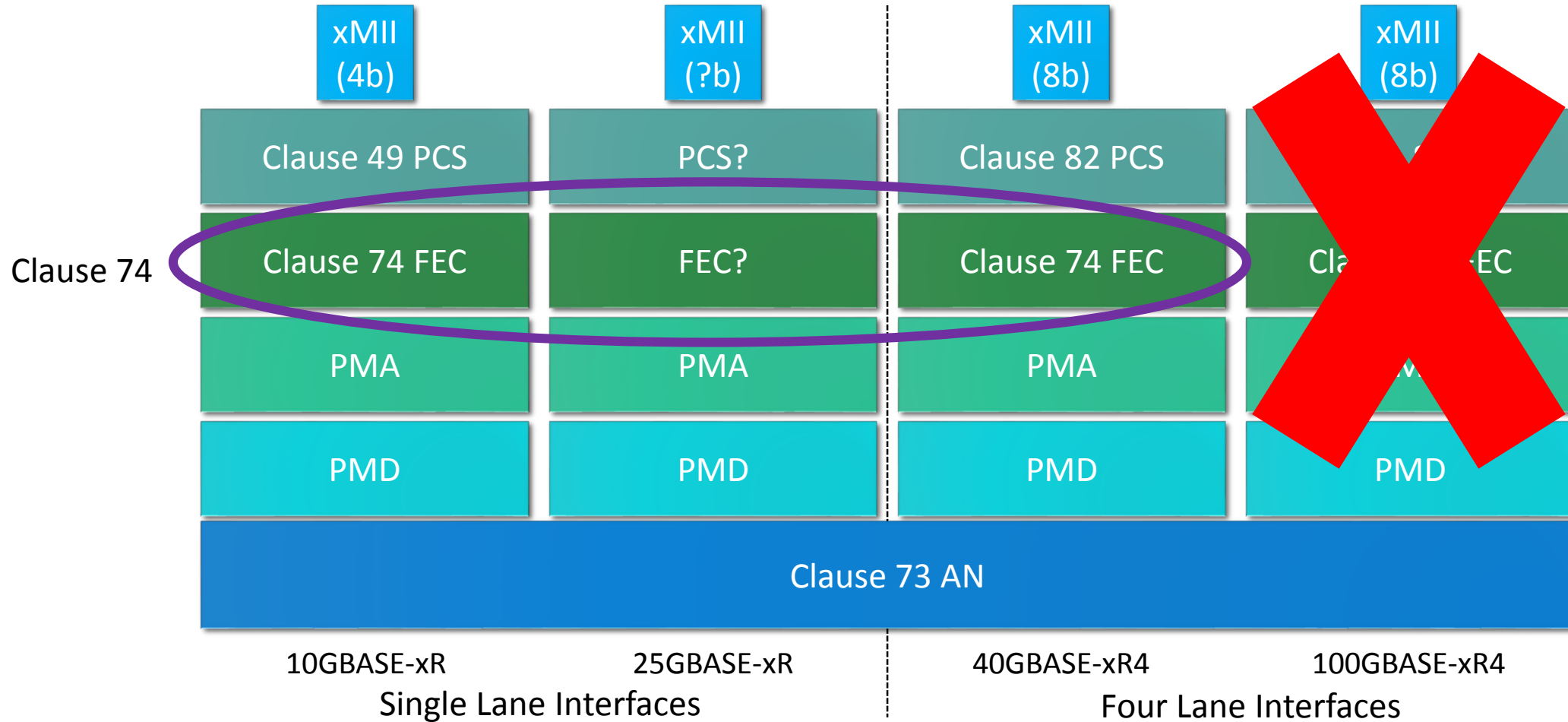

# Resulting Block Diagram – Copper

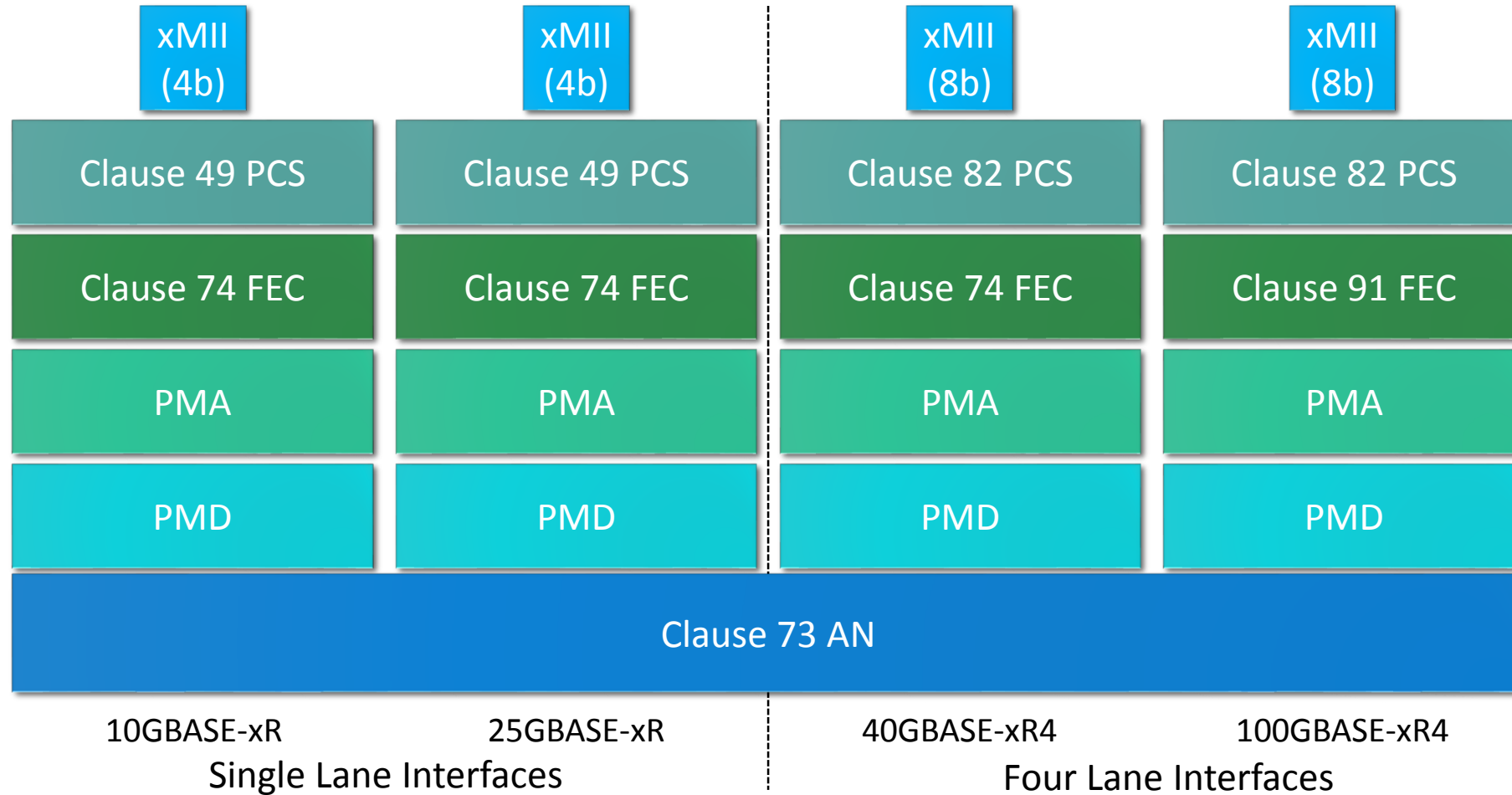

# Copper Observations

---

Auto-negotiation is a very helpful option

- If not used, the port will be managed to be a specific port type

## 10G/25G NIC

- Support of Clause 49 PCS and Clause 74 FEC would be the simplest from an implementation and silicon cost point of view
- MAC/RS/xMII would be closest between 10G and 25G

## 10G/25G/40G NIC

- Both Clause 49 and Clause 82 PCS would need to be supported
  - No different than existing 10G/40G implementations available today
- Clause 74 FEC (optional) could be shared across all port types
- Clause 91 FEC would be an addition to existing 10G/40G implementations

# Optics

---

# 802.3-2012 10G SR Optics

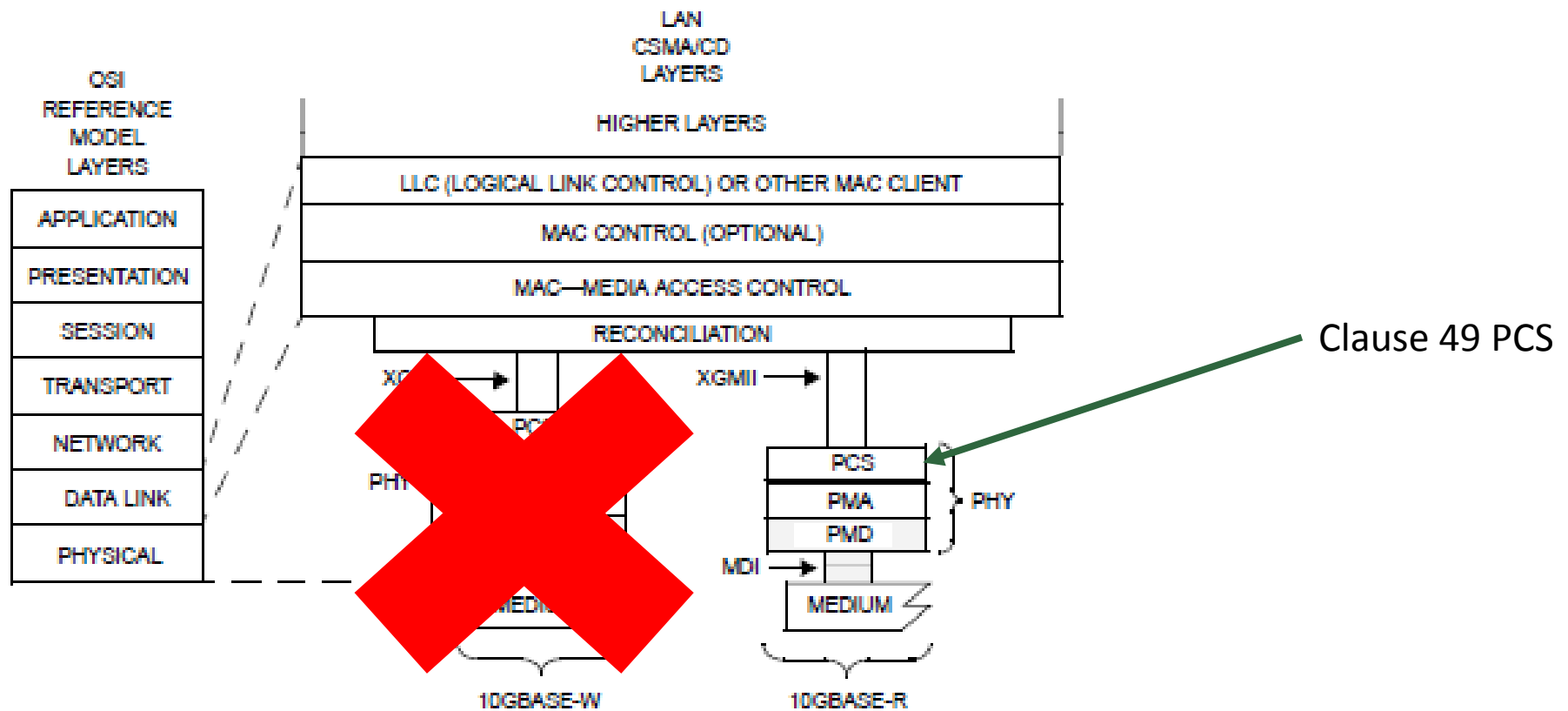

# 802.3-2012 40G SR4 Optics

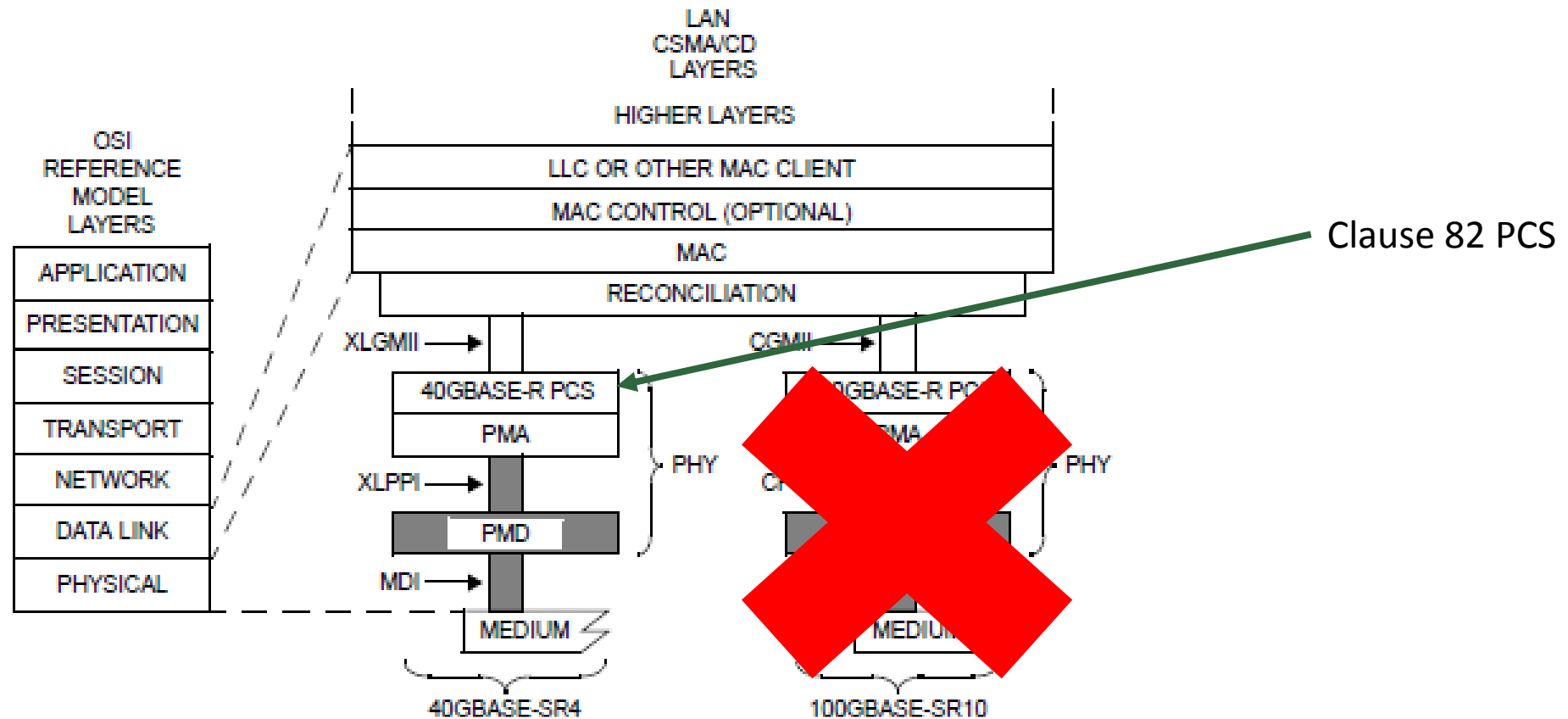

# P802.3bm 100G SR4 Optics

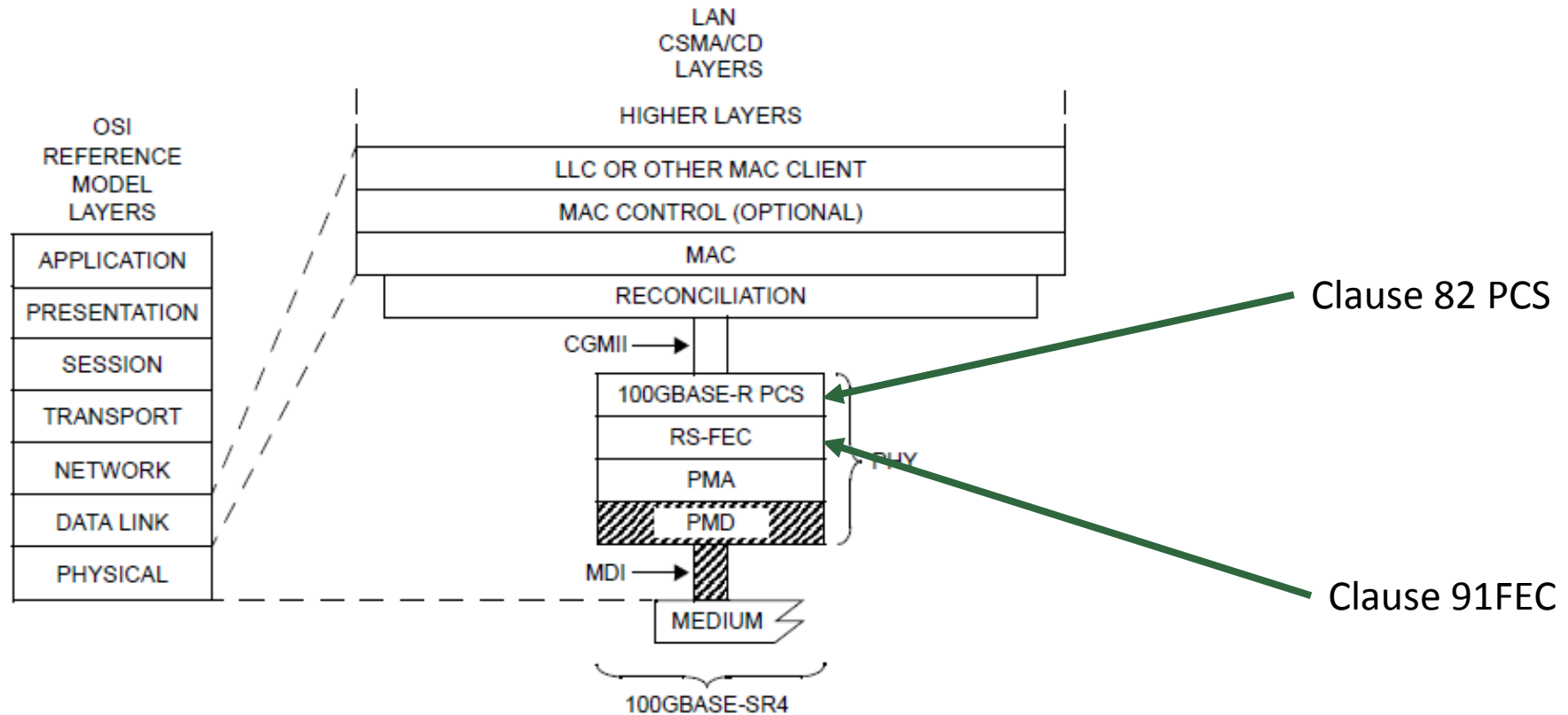



# Architectural Overview – What FEC and PCS for 25G Optical?

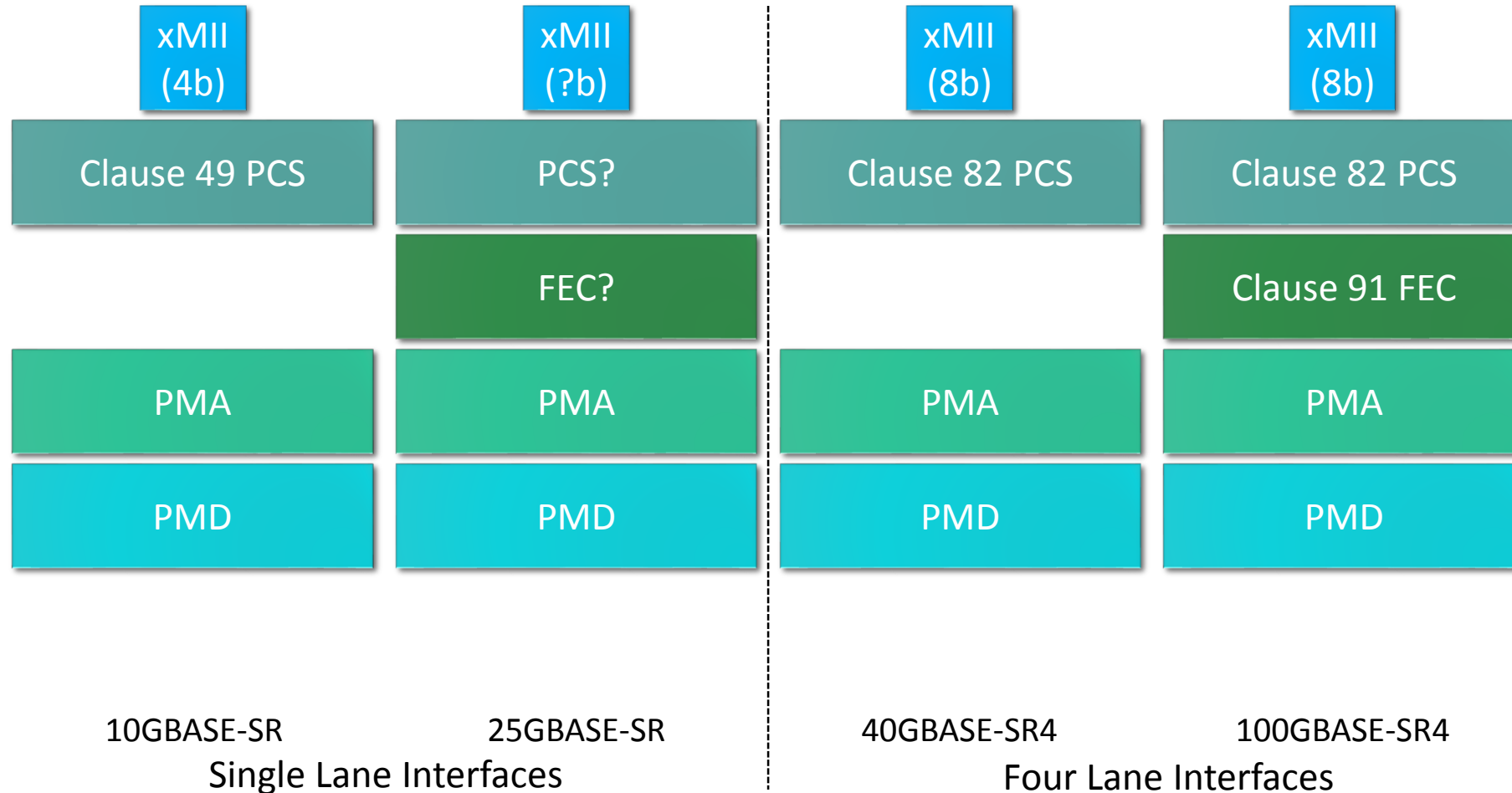

# 10G and 25G Network Interface Card

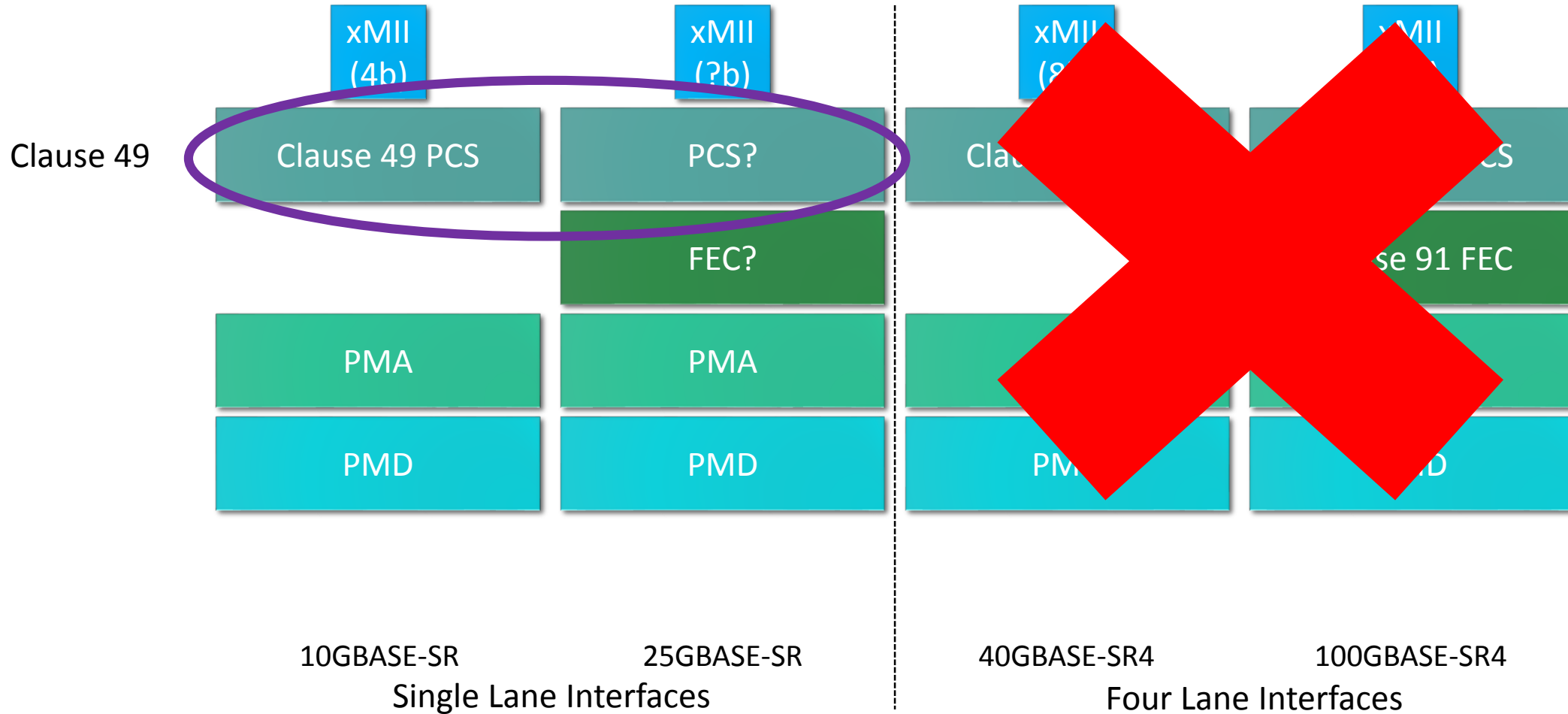

# 10G/25G/40G Network Interface Card

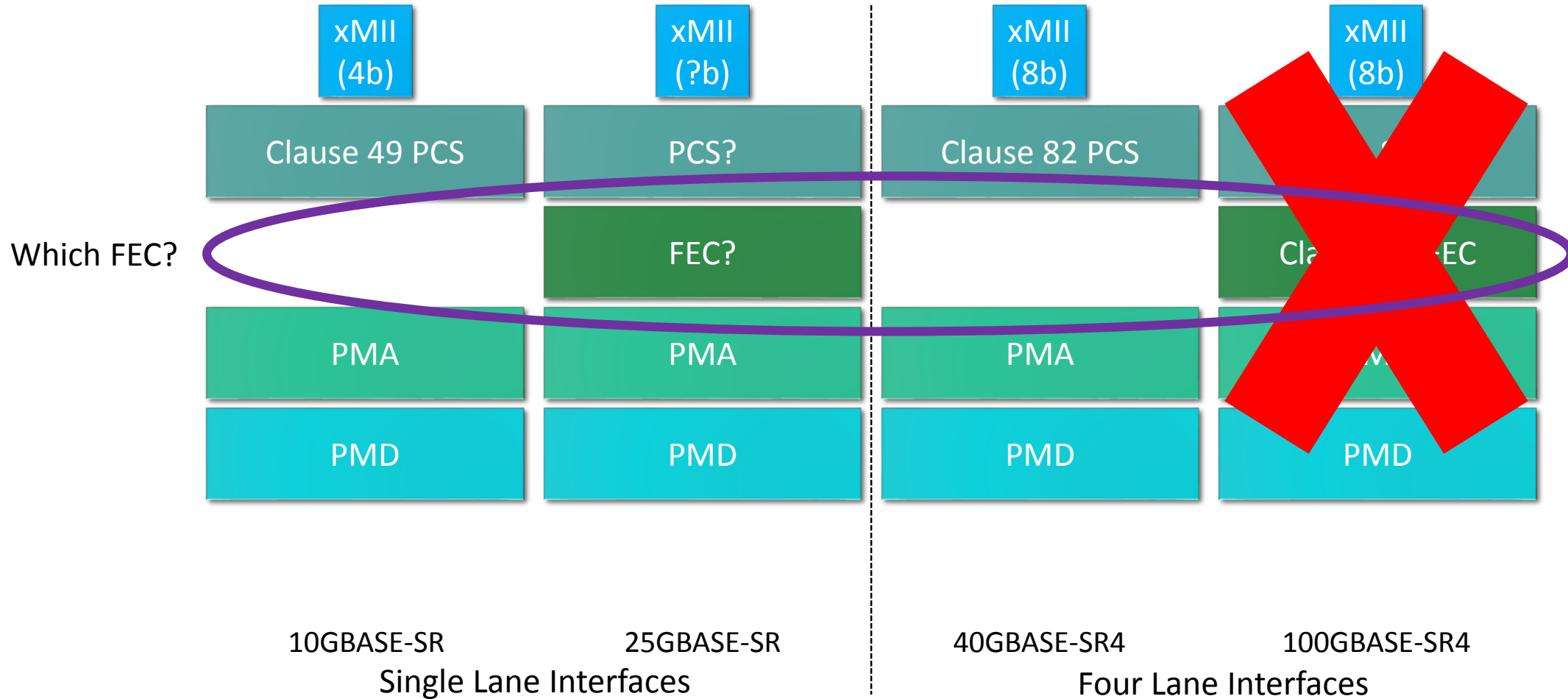

# Change the View – Interface Rate

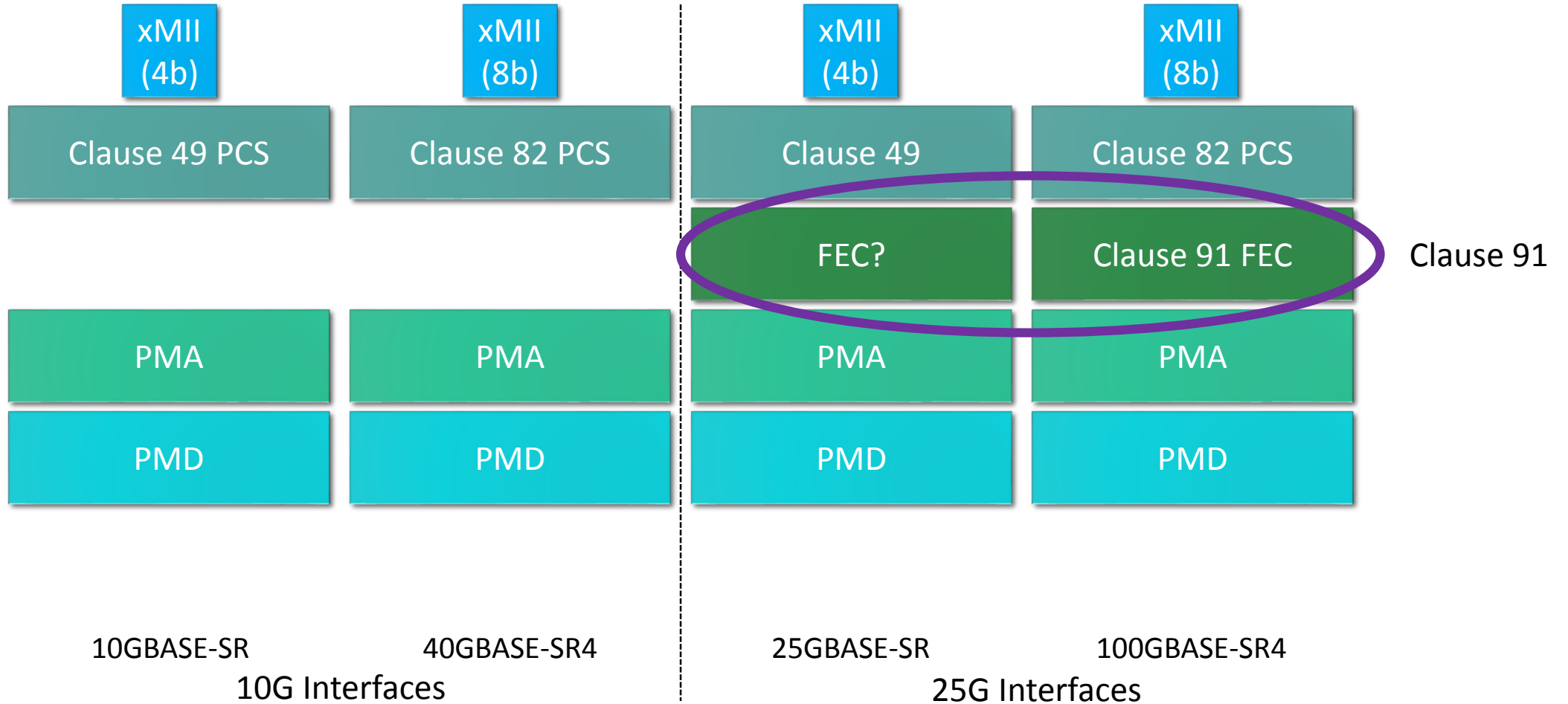

# Resulting Block Diagram – Optical

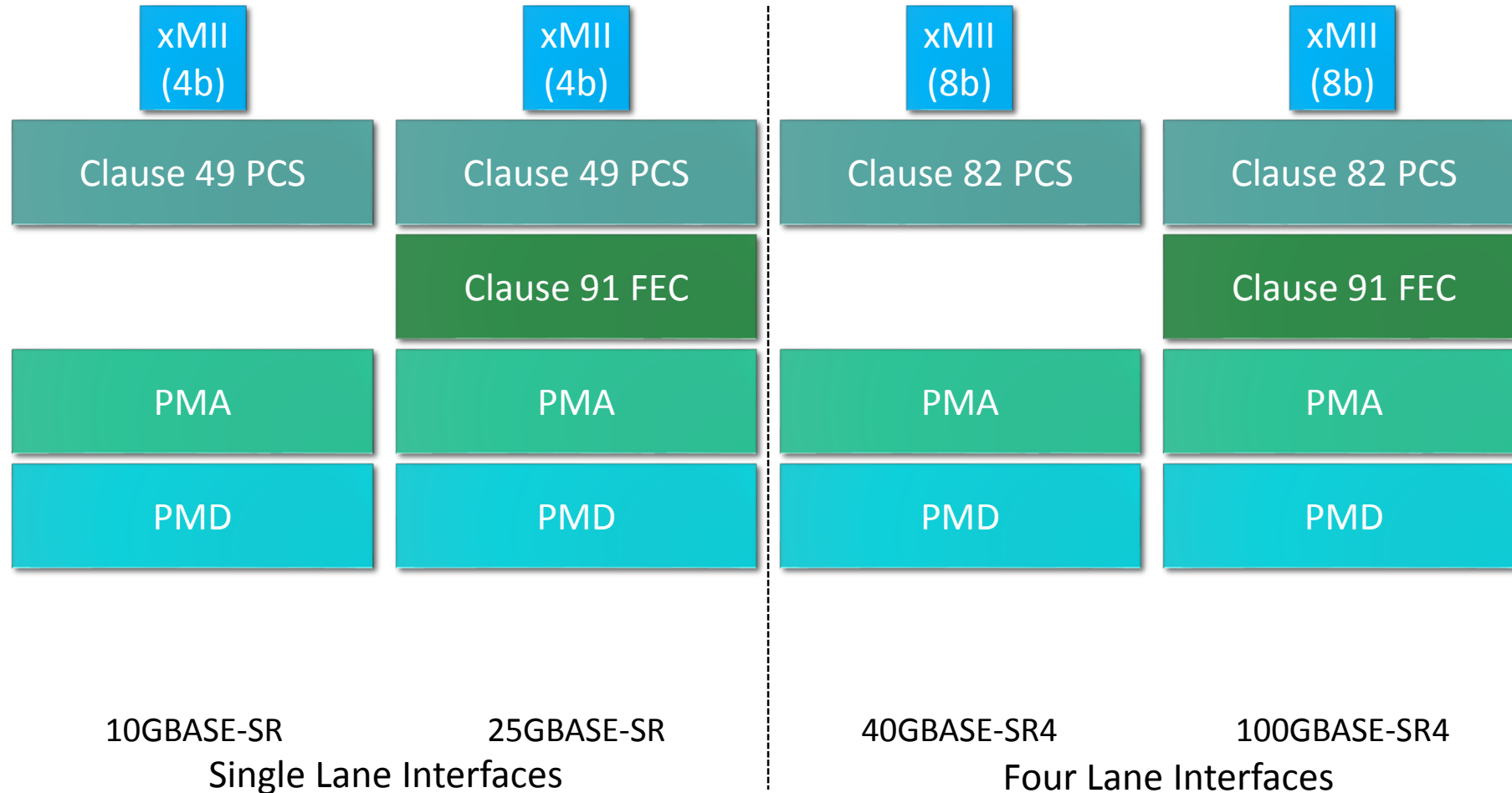

# Optical Observations

---

No auto-negotiation capability

## 10G/25G NIC

- Support of Clause 49 PCS would be the simplest from an implementation and silicon cost point of view
- Channel capabilities are different though
- MAC/RS/xMII would be closest between 10G and 25G

## 10G/25G/40G NIC

- Both Clause 49 and Clause 82 PCS would need to be supported
- No FEC exists for 10G or 40G optical
- How likely is 10G/25G/40G to be implemented due to difference in connector

Clause 91 FEC would offer compatibility to 100GBASE-SR4

- And to 100GBASE-KR4 and CR4!

# OTN Thoughts

---

OTN not used between server and switch; only in switch to switch connections

MMF is used in the switch to OTN connection

- Copper is not used today, but cannot guarantee that moving forward
- Compatibility between copper and MMF bit stream is helpful

Link into and out of OTN needs to operate in same manner as though the OTN doesn't exist

- Treat the OTN as only a media translator

Assume that any connection to OTN must be based upon Clause 49 PCS and Clause 91 FEC

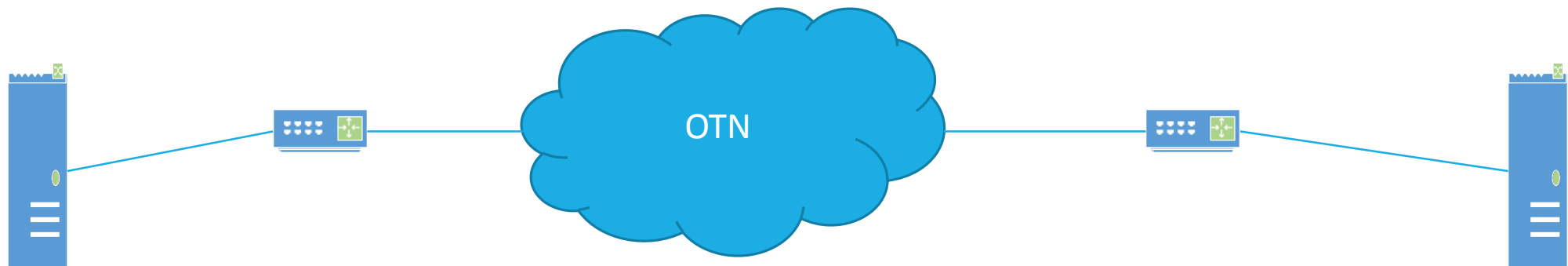

# General Observations

---

## PCS selection

- Clause 49 as the single-lane
- Clause 82 as the multi-lane
- Easiest to support Clause 49 in a 10G/25G NIC implementation

## FEC selection

- Analyzing from a SerDes interface point of view
- FEC choice would best match that of the similar data rate
- RS-FEC may be a requirement for the 5m channel or MMF
- Clause 74 for 10G SerDes and RS-FEC for 25G SerDes
- Auto-negotiation would permit selection of the FEC to be done prior to link establishment



# Recommendations

---

Select Clause 49 as the PCS for 25G

- Single-lane 10G/25G NICs are likely to be lion share
- Clause 82 is a great multi-lane PCS, but has greatest impact to re-use of 10G implementations

Use auto-negotiation to select the FEC for twinax and backplane

- For copper NICs, FEC could be:
  - Off
  - Clause 74 FEC (optional)
  - Clause 91 FEC (mandatory except with 3m DAC)

For optical implementations, FEC would be based on Clause 91

For OTN connectivity, FEC should be based on Clause 91

- Per above, this would work with both MMF and copper interconnect

# Thank You!

---