

IEEE802.3 4P Task Force  
**Channel Pair To Pair Resistance Imbalance**  
(End to End System Imbalance)  
**Ad Hoc**  
Norfolk VA  
May 2014

Meeting #1: Rev\_001 Monday February 17, 2014

Meeting #2: Rev\_001b Monday February 24, 2014

Meeting #3: Rev 004, Thursday April 24, 2014

Meeting #4: Rev 005, Thursday May 1, 2014

Meeting #5: Rev 006, Thursday May 8, 2014

Meeting #5: Rev 008, Thursday May 8, 2014, Ad-hoc report for May 2014 meeting.

Meeting #6: Rev 009, Thursday May 15, 2014 , Norfolk VA.

Meeting #7: Rev 009, Tuesday June 10, 2014 , Norfolk VA.

Yair Darshan  
Microsemi  
ydarshan@microsemi.com

# Meeting # 7 Attendees (June 10, 2014)

## Meeting # 7

Yan Zhuang / Huawei

Ronald Tellas / Panduit

Larsen, Wayne / Commscope

Jeff Heath / LT

Brian Buckmeier / BEL

Rick Frosch / Phihong

Christian BEIA / ST

Leonard Stencil / Bourns

Fred Schindler / Seen Simply

Koussalya Balasubramanian / Cisco

David Tremblay / HP

David Abramson / TI

Rimboim Pavlik / Microsemi

Yair Darshan / Microsemi

Ken Bennett / Sifos

Victor Renteria / BEL

George Zimmerman/ CME Consulting, Affiliations: Commscope & Aquantia

Steinke, Stephan / Molex

Gaojing Zou / Maxim

Jean Picard / TI

Wendt, Matthias / Philips

Please send email after the meeting to confirm your attendance.

# Introduction

---

- The purpose of this ad-hoc is to recommend the Task-Force for what is needed to specify the channel pair to pair resistance unbalance while considering not only the formal channel components (Cable and Connector) but also the Power Interface (PI) components at both ends of the 4P PoE system.
- Patent Policy
  - Please read the Patent Policy slides at <http://www.ieee802.org/3/patent.html> prior the meeting.

# Where we are and where we are going?

-Single maximum number.

-E.g. a single number max, in the **25% -50% range** (TBD)

-Single maximum number.

-E.g. a single number max, in the **5% -20% range** (TBD)

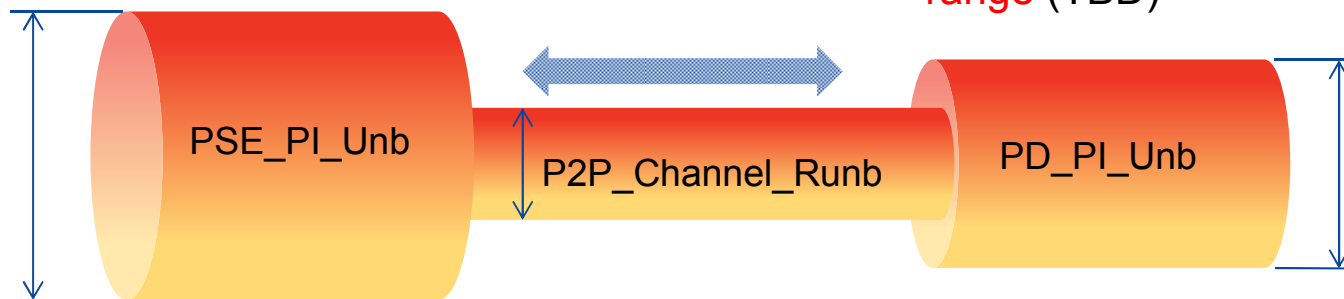

-Variable Channel Length

-Worst Case Runb

-**7 to 9% max. or 0.1Ω max** which ever is greater.  
function of # of connectors and cable length

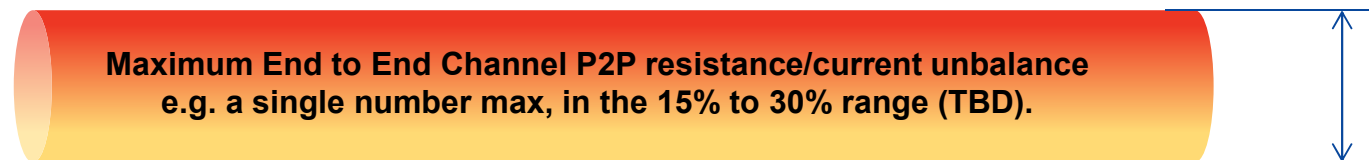

**Maximum End to End Channel P2P resistance/current unbalance**  
e.g. a single number max, in the **15% to 30% range** (TBD).

- Channel capable of regulating/reducing of end to end unbalance as function of channel length.
- PD PI need to be better than PSE PI due to its higher effectiveness on end to end unbalance.
- PSE PI needs larger unbalance range to allow different implementations

# Proposed Agenda, Meeting #7, June 10, 2014.

---

- Introduction, Patent policy (1 minute)
- Where we are and where we are going? (10 minutes)
- Worst Case Data Base (updates) (10 minutes)
- Closing on a number for Channel P2PRUNB (10 minutes)
- Previous summary of closed A.I. and updates (please review prior the meeting)
- PSE PI P2P model concept (10 minutes)
- PD PI P2P model concept (1 minute)
- Reviewing Ken Bennett Presentation (10 minutes)
- Summary and Action Items (8 mintues)

# Where we are and where we are going? -1

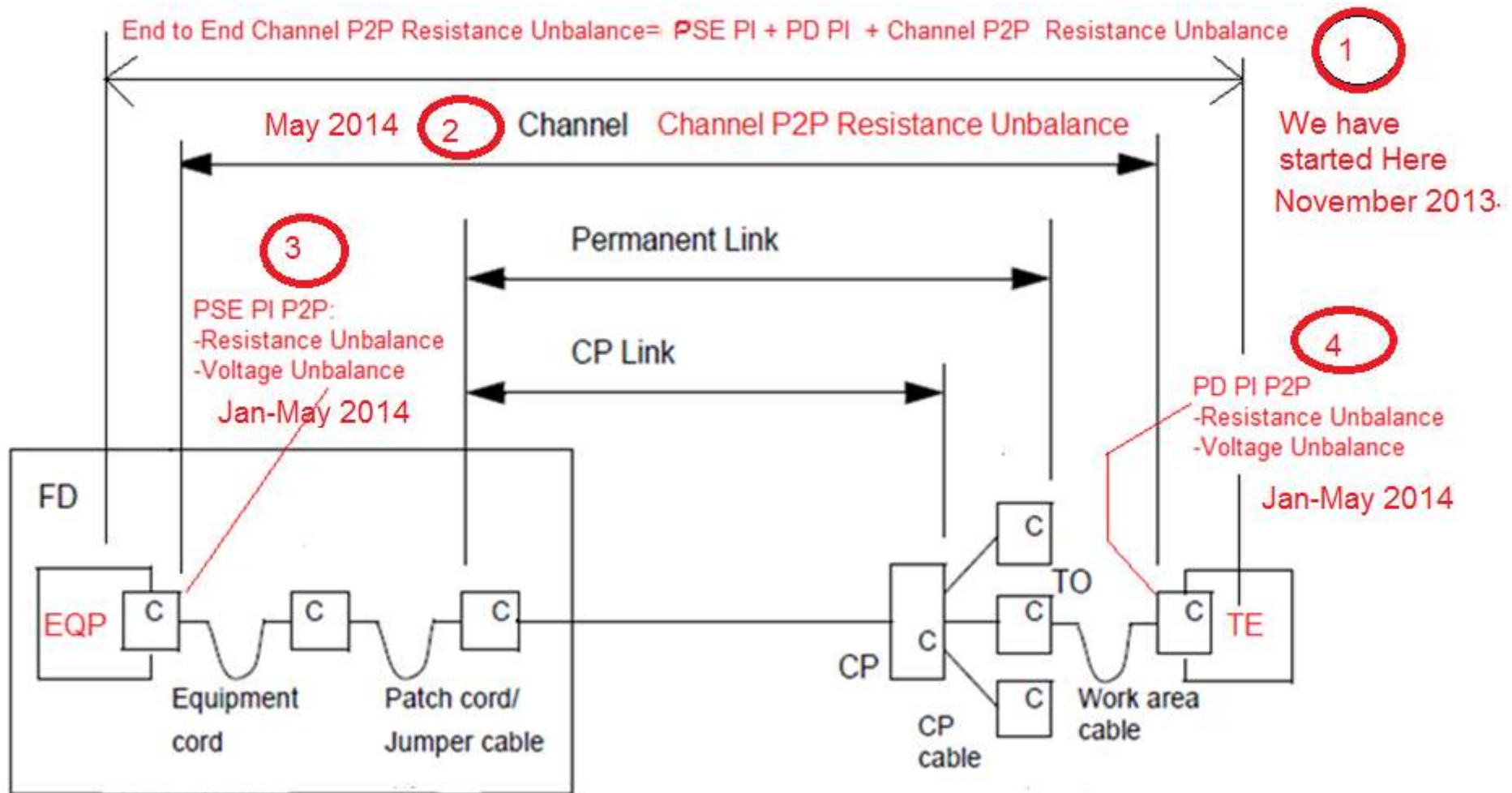

Figure 1. May 27, 2014

Ad-hoc response, June 10, 2014. TBD

# Where we are and where we are going? -2

#	Parameter	Part of the spec.	Status
1	End to End Channel Pair to Pair Resistance Unbalance	No	-We have worst case numbers based on worst case data base. -Database is updated on the fly.
2	Channel Pair to Pair Resistance Unbalance	Yes	-Baseline text motion passed. -Numbers 0.2Ω, 6% max (TBD) -Working on 6% → higher
3	PSE PI Pair to Pair Resistance Unbalance	Yes	-Consensus that P2P resistance unbalance need to be specified together with Voltage unbalance.
4	PD PI Pair to Pair Resistance Unbalance	Yes	-Models being discussed for testing, no complete work yet. -Numbers need to be derived from (1) and (2).

We agree that the above parameters will be calculated/defined at room temperature or close to it (see details next slide).

There is a consensus that the temperature will be 20°C. Ad-hoc to confirm on meeting #7

Ad-hoc response, June 10, 2014. TBD

# Where we are and where we are going? -3

---

- Adhoc has recommended the following approach (meetings 5,6)
  - How to handle PSE PI, PD PI Pair to Pair unbalance parameters and Channel P2RUNB as function of temperature?
    - Adhoc response:
    - Use PSE PI, PD PI pair to pair Unbalance parameters and Channel P2PRUNB that was calculated at 20°C (or pick a number at other temperature).
    - Set it as the number to meet without saying at what temperature it is.
    - Vendors will have to assure that they meet it at their operating temperature range spec.
    - How they will do it, we don't care. The rest is per 33.7.7.



# Where we are and where we are going? -4

- End to End Channel P2P RUNB.

- Using Annex F model.
- Ignoring Vdiff in PSE PI and PD PI for simplicity. Later their effects will be added as additional resistance term or other method.

$$E2E\_C\_P2PRUNB = \frac{\sum R_{\max} - \sum R_{\min}}{\sum R_{\max} + \sum R_{\min}} =$$

$$= \frac{R_{pse\_max} + R_{pd\_max} + R_{ch\_max} - R_{pse\_min} - R_{pd\_min} - R_{ch\_min}}{R_{pse\_max} + R_{pd\_max} + R_{ch\_max} + R_{pse\_min} + R_{pd\_min} + R_{ch\_min}} =$$

$$= \frac{(R_{pse\_max} - R_{pse\_min}) + (R_{pd\_max} - R_{pd\_min}) + (R_{ch\_max} - R_{ch\_min})}{\sum R_{\max} + \sum R_{\min}} =$$

$$E2E\_C\_P2P\_RUNB = \frac{(R_{pse\_max} - R_{pse\_min})}{\sum R_{\max} + \sum R_{\min}} + \frac{(R_{pd\_max} - R_{pd\_min})}{\sum R_{\max} + \sum R_{\min}} + \frac{(R_{ch\_max} - R_{ch\_min})}{\sum R_{\max} + \sum R_{\min}}$$

# Where we are and where we are going? -4

-Single maximum number.

-E.g. a single number max, in the **25% -50% range** (TBD)

-Single maximum number.

-E.g. a single number max, in the **5% -20% range** (TBD)

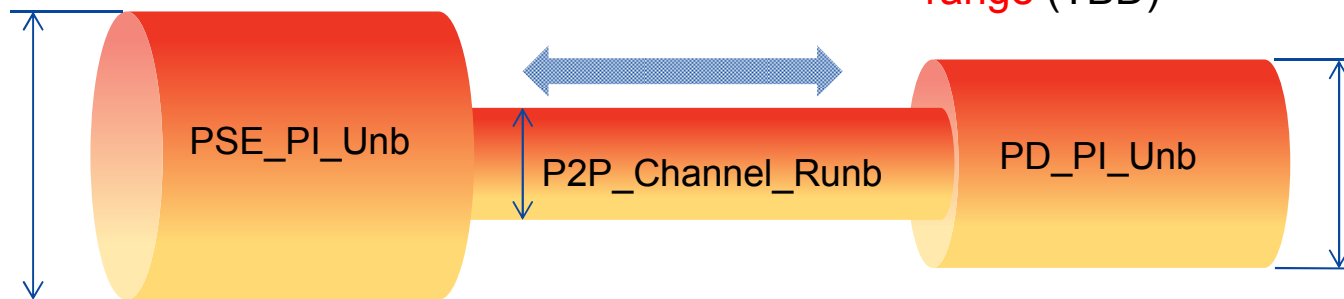

-Variable Channel Length

-Worst Case Runb

-**7 to 9% max. or 0.1Ω max** which ever is greater.  
function of # of connectors and cable length



- Channel capable of regulating/reducing of end to end unbalance as function of channel length.
- PD PI need to be better than PSE PI due to its higher effectiveness on end to end unbalance.
- PSE PI needs larger unbalance range to allow different implementations

# Where we are and where we are going? -5

## ■ How to specify PSE and PD PI (opt A: through simulation).

- Step 1: Find End to End maximum current/resistance unbalance max limit. (We already have worst case numbers based on worst case data base)
- Step 2: Find/define convenient, practical PD max. unbalance parameters (voltage and resistance)
- Step 3: Use calculated Channel maximum Runb at the working point of Step 1.
- Step 4: Change PSE PI Vdiff\_max, Rdiff\_max, Rmin parameters to achieve maximum Runb until the limits of Step 1 is crossed.

## ■ How to specify PSE and PD PI (opt B: The analytical way).

$$\frac{(R_{pse\_max} - R_{pse\_min})}{\sum R_{max} + \sum R_{min}} + \frac{(R_{pd\_max} - R_{pd\_min})}{\sum R_{max} + \sum R_{min}} + \frac{(R_{ch\_max} - R_{ch\_min})}{\sum R_{max} + \sum R_{min}} =$$

$$K_{pse} \cdot \frac{(R_{pse\_max} - R_{pse\_min})}{\sum R_{max} + \sum R_{min}} + K_{pd} \cdot \frac{(R_{pd\_max} - R_{pd\_min})}{\sum R_{max} + \sum R_{min}} + K_{ch} \cdot \frac{(R_{ch\_max} - R_{ch\_min})}{\sum R_{max} + \sum R_{min}}$$

- Find Kpse, Kpd and Kch that meets the limits of step 1.
- Kxx may be a Vandermonde matrix for perfect fitting or scalar for worst case points only.

# Annex G1:Worst Case Data Base (updates)

-1

#	Parameter	Data set 1	Data set 2
1	Cordage resistivity	Patch cords (cordage): 0.14Ω/m	
2	Horizontal cable resistivity <sup>2</sup> option 1	117Ω/100m=(12.5Ω-4*0.2Ω)/100m which is the maximum resistance resulting with maximum Iport.	6.6Ω/100m* (CAT6A, AWG23) This is to give us maximum P2P Runb.
3	Cable resistivity/data option 2 <sup>3</sup>	0.098Ω/m.	
4	Unbalance parameters	<ul style="list-style-type: none"> <li>Cable Pair resistance unbalance: 2%. Channel pair resistance unbalance: 3%</li> <li>Cable P2P Resistance Unbalance: 5%. <b>Channel P2P Resistance Unbalance: 0.2Ω/6% max TBD.</b></li> </ul>	
5	Channel Lengths: Use Cases to check. See figure 1 for what is a channel.	A. 6 inch (0.15 m) of cordage, no connectors. B. 4 m channel with 1 m of cordage, 3 m of cable, 2 connectors C. 23 m channel with 8 m of cordage, 15 m of cable, 4 connectors D. 100m channel with 10 m of cordage, 90 m of cable, 4 connectors	
6	End to End Channel length <sup>6</sup>	The Channel per figure 1 + the PSE and PD Pls.	
7	Transformer winding resistance	120mOhm min, 130mOhm max	
8	Connector resistance <sup>8</sup>	30mOhm min, 60mOhm max 45mOhm min, 60mOhm max	30mOhm min, 60mOhm max 30mOhm min, 45mOhm max
9	Diode bridge <sup>9</sup>	Discreet Diodes: 0.39V+0.25Ω*Id min; 0.53V+0.25Ω*id max.	
10	PSE output resistance <sup>10</sup>	0.25+0.1 Ohm min, 0.25+0.2 Ohm max	0.1+0.05 Ohm min, 0.1+0.1 Ohm max

Ad-hoc response, June 10, 2014. TBD

# Annex G2: Worst case data base- Notes. -2

- 2. We need both data sets (data set 1 and data set 2) to find where is the worst condition for maximum current unbalance. See Annex B curve and data showing that at short channel we get maximum P2PRUNB but it has less concern to us since the current is lower. We need to do all use cases calculation to see where current increase over a pair is the maximum.  $0.066\Omega/m$  is not depend on twist rate, it is a constant at  $20^{\circ}\text{C}$ . We need just to add twist rate effect to cable length e.g. for CAT6A twist rate may be 10-12% increase in actual wire length.
- 3. This is to check if it is useful since it is between data set 1 and data set 2 of option 1. In addition, it will be used also to check/define channel P2PRUNB per Wayne Larsen proposal.
- 6. PSE PI and PD PI includes: connector, transformer, resistors. PD PI includes diode bridge.
- 8. Connector resistance was changed since the difference (60-30) miliOhm is not representing  $R_{diff}$ , it is representing maximum and minimum results of connector resistance of different connectors. To correct it, we change the numbers according to inputs from connector vendors and measured data. [See Annex E1-E6 for confirmation.](#)
- 9. Discrete diode. Not recommended to use. Worst case numbers. No control on  $V_f$  and  $R_d$ . It is recommended to use matched components for much better unbalance.
- 10. PSE output resistance e.g.  $R_{s\_a/b} = R_{sense} + R_{dson}$  in addition to winding resistance

Ad-hoc response, June 10, 2014. TBD

# Closing on a number for Channel P2PRUNB

- Typical “worst case values”
- Connector Rdiff=0.02Ω max.
- Connector Rmax=0.05, 0.06 Ω.
- Cordage: 0.14 Ω/m
- Cable: 0.066, 0.098 Ω/m, 0.117
- Red marks are the cause for high CP2PRUNB

Not Make sense connector data pairs				
#	Rmax miliΩ	Rdif miliΩ	Rmin miliΩ	Notes
1	201	-	-	200 max, standard
2	-	51	-	50 max, standard
3	60	10	50	Field results, 20 max
4	61	-	-	Field results, 60 max
5	-	30	-	Field results, 20 max
6				
7				
8				

#	Connectors	Cordage[m]	Cable[m]	Max. Channel P2PRUN
A	0	≥0.15	0	5% (equal to Cable P2PRUNB)
A1	0	0	≥0.15	
B	2	1	3	8.9% → Spec: 9%
C	4	8	15	6.47%
D	4	10	90	5.45%

Recommendation: To specify PD PI to be > Channel P2PRUNB and < PSE PI unbalance.

# Channel P2P Runb vs. P2P resistance difference

Use case #	A	B	B1	B2	B3	B4	B5	B6	C	C1	C2	D
#Connectors	0	2	2	2	2	2	2	2	4	4	4	4
Cordage[m], 0.14ΩΩ/m	0.15	1	2	3	4	5	6	7	8	9	9	10
Cable[m], CAT6A, AWG230.m	0	3	5	7	9	11	13	14	15	30	40	90

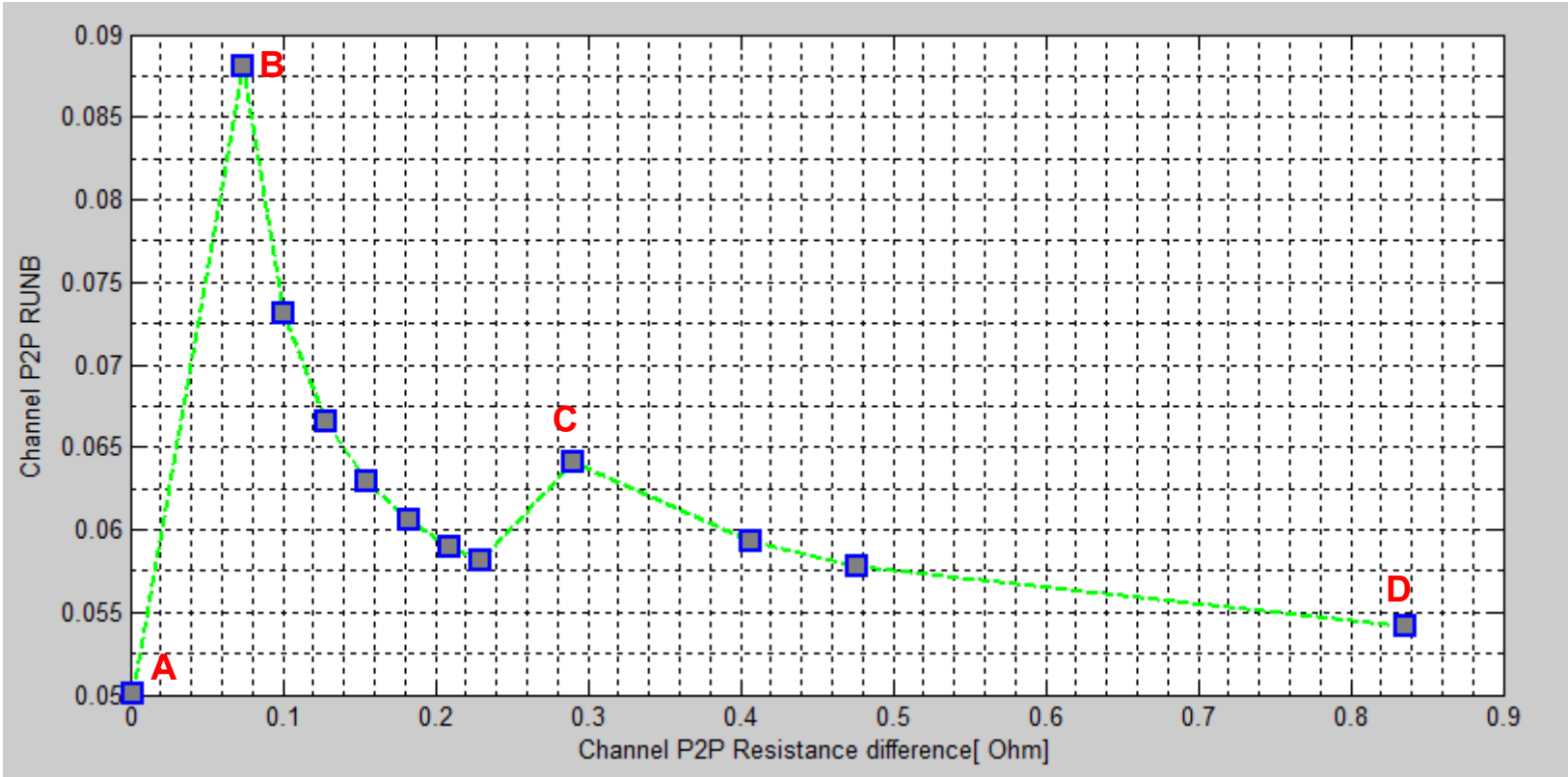

# Channel P2P Runb vs. P2P resistance difference

---

- Conclusions:
- To change TBDs in our last motion to:
  - 0.1 ohm max instead of 0.2 ohms max.
  - 9% max instead of 6%.
    - To work on ideas how to reduce to 7% max.
    - Example: To require 0.1 $\Omega$ (TBD) minimum channel resistance

Ad-hoc response, June 10, 2014. TBD



# PSE PI P2P model concept

-1

- PSE PI model derivation

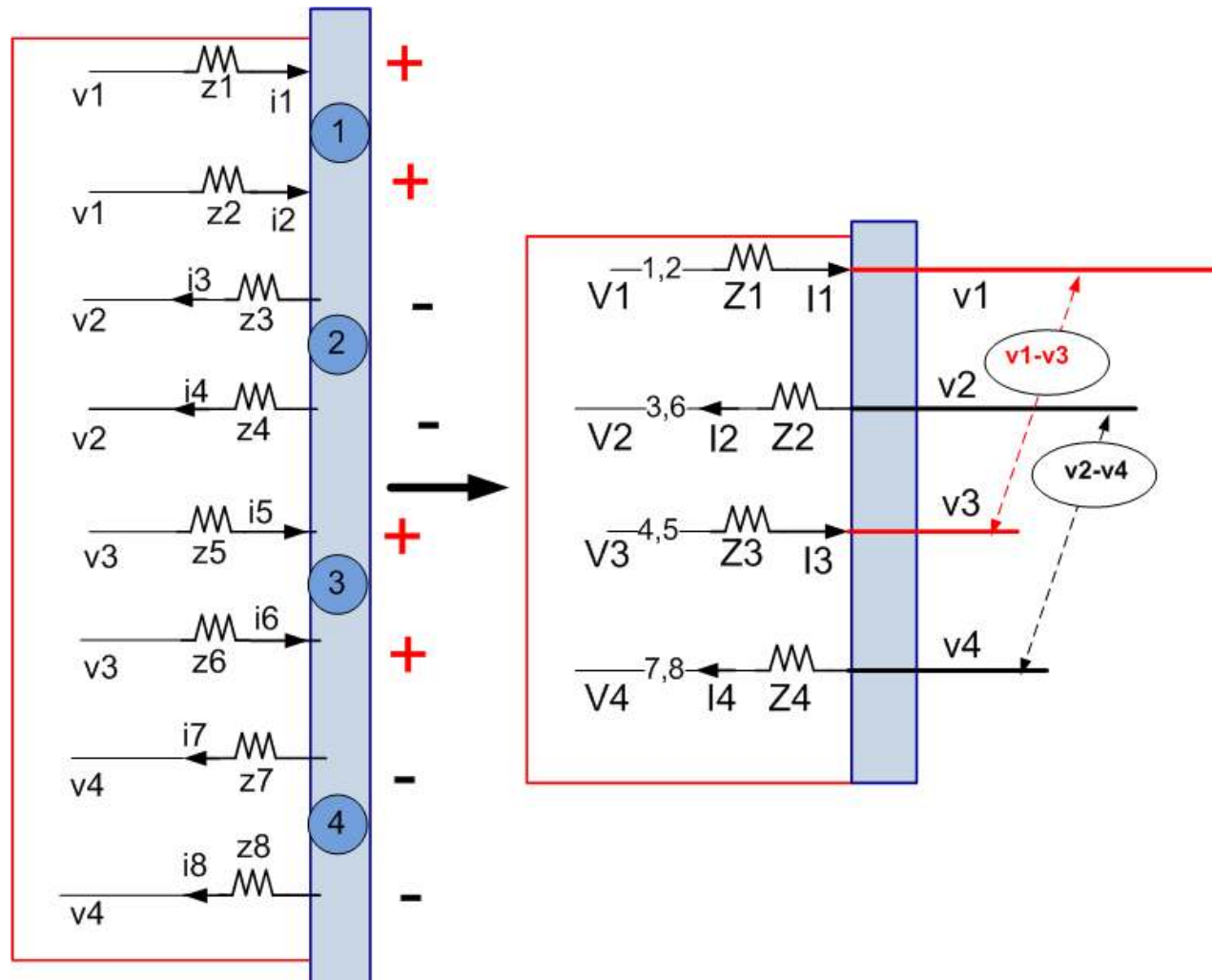

# Requirement Derivation - 1

- By definition:
- $I1=(V1-v1)/Z1 \rightarrow Z1=(V1-v1)/I1$
- $I2=(V2-v2)/Z2 \rightarrow Z2=(V2-v2)/I2$
- $I3=(V3-v3)/Z3 \rightarrow Z3=(V3-v3)/I3$
- $I4=(V4-v4)/Z4 \rightarrow Z4=(V4-v4)/I4$
  
- By definition:
- P2P PSE PI Zunbalance=

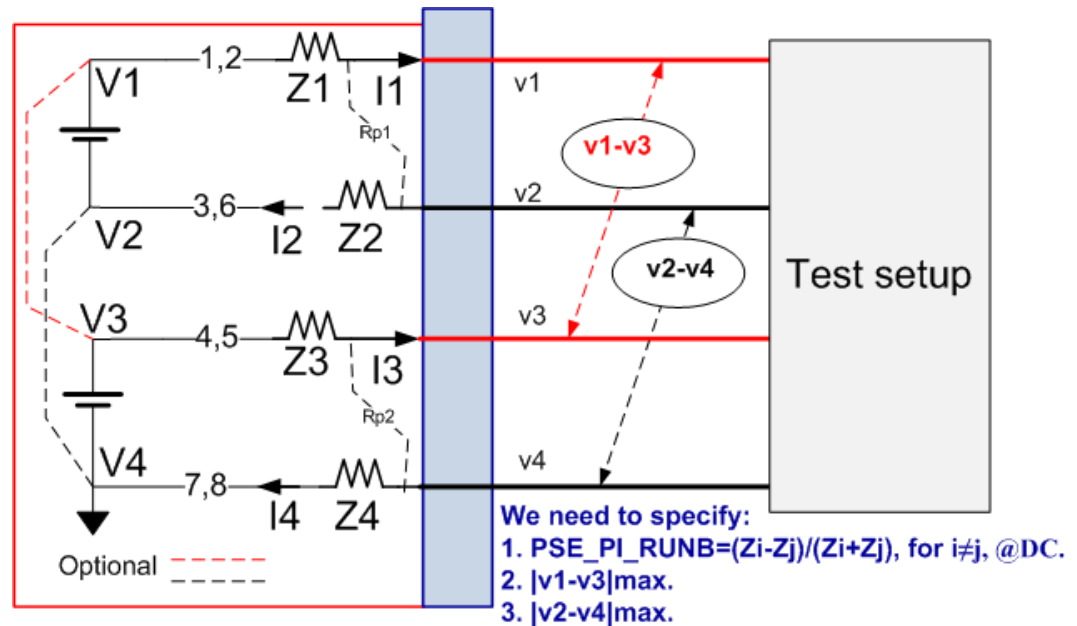

In one typical application:  $V1=V3, V2=V4=0$ .  
 As a result, open load voltages:  $v1-v3 \rightarrow 0, v2-v4 \rightarrow 0$

$$= \frac{Z_i - Z_j}{Z_i + Z_j} = \frac{\frac{V_i}{I_i} - \frac{V_j}{I_j}}{\frac{V_i}{I_i} + \frac{V_j}{I_j}} = TBD \max \quad \text{Between any two pairs } i \neq j .$$

# Requirement Derivation - 2

- P2P PSE PI Zunbalance=

$$= \frac{Z_i - Z_j}{Z_i + Z_j} = \frac{\frac{V_i - V}{I_i} - \frac{V_j - V}{I_j}}{\frac{V_i - V}{I_i} + \frac{V_j - V}{I_j}} = TBD \max$$

Between any two pairs  $i \neq j$ .

Since we need Z in DC  $\rightarrow Z \rightarrow R$

$$(1) \frac{Z_i - Z_j}{Z_i + Z_j} = \frac{R_i - R_j}{R_i + R_j} = P2PRUNB \max,$$

$$(2) |v_1 - v_3| < TBD$$

$$(3) |v_2 - v_4| < TBD$$

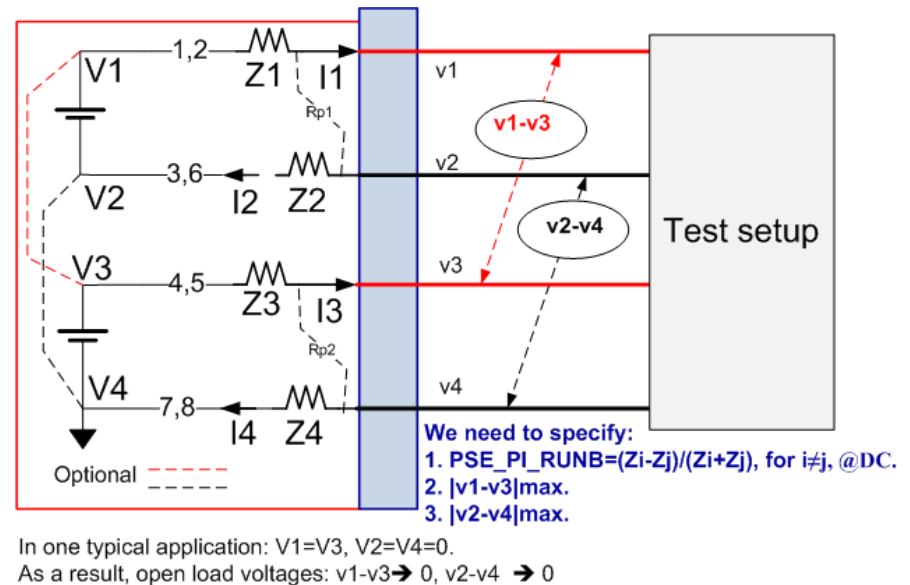

$R_i$  is function of  $V_i/I_i$  which addresses non linear circuitry at worst case unbalance operating point defined by PSE vendor.

# PSE PI P2P model concept

-3

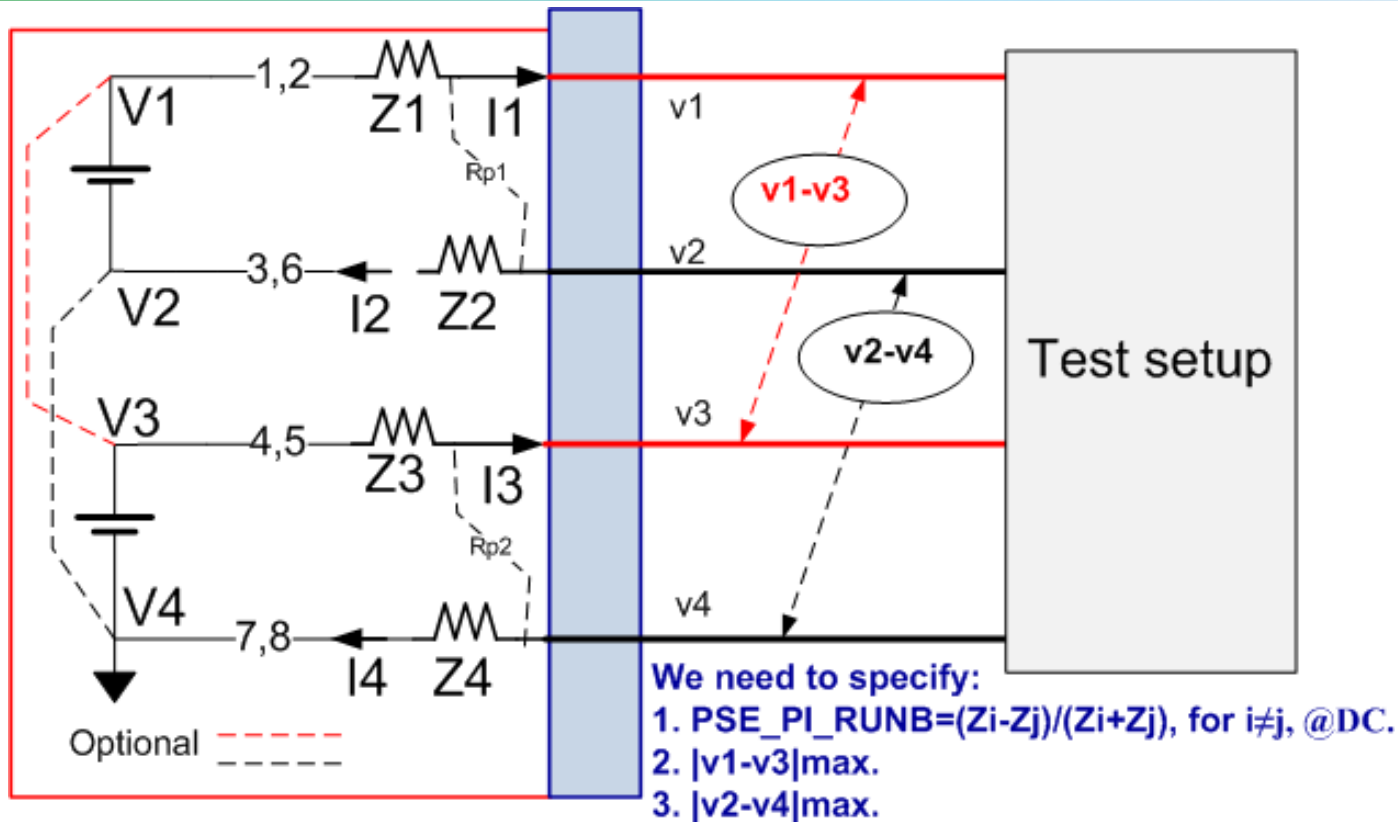

In one typical application:  $V1=V3$ ,  $V2=V4=0$ .

As a result, open load voltages:  $v1-v3 \rightarrow 0$ ,  $v2-v4 \rightarrow 0$

- In the test setup, it is possible to find P2PRUNB by measuring currents at PSE normal powering state. But this is test setup implementation issue and not part of the specification. The spec defines Voltage and Resistance to maintain implementation independent specifications.

- Part A:
- Specifying PSE P2P\_R\_UNB and PSE\_P2P Voltage Difference
  - PSE P2P Voltage difference at no load condition.
    - Voltage difference between the two positive voltage rails
    - Voltage difference between the two negative voltage rails
  - P2P\_R\_UNB, will be single number, maximum number.
- Part B:
- Defining test model and test conditions.
- Ad hoc response: TBD

- Proposed base line text:
- **33.1.4.xx Type 3 and Type 4 PSE PI Requirement for Pair to Pair unbalance**
- 4P pair operation requires the specification of resistance unbalance between each two pairs of the PSE PI, not greater than TBD milliOhms or **TBD%** which ever is greater. The resistance unbalance requirements between each two pairs of the PSE PI shall be met for a maximum voltage difference TBDmVdc between the two positive pairs and between the two negative pairs. The Resistance unbalance between the PSE PI pairs is a measure of the difference of resistance of the common mode pairs of conductors used for power delivery. See figure TBD for PSE PI model. PSE PI pair to pair resistance unbalance is defined by equation 33-1.XX:
- **Insert Equation here that ties Resistance and voltage unbalance together.**
- **Equation TBD** 33-1.xxx

Where:

Rpse\_max is the sum of PSE PI pair elements with highest common mode resistance.

Rpse\_min is the sum of PSE PI pair elements with lowest common mode resistance

Common mode resistance is the resistance of the elements over each PSE PI wires in the PI pair connected in parallel.

# PD PI P2P model concept

---

- TBD
- Looking for volunteers to do it.

# Proposed Action items

---

- All: To review open issues and comment
- Ken, others: To suggest complete test setup for PSE PI P2P compliance tests.
- All: To review PSE PI proposals and comment and comment on open issues.
- Yair, Christian: To specify PD PI and PSE PI numbers based on Channel P2PRUNB numbers and End to End Channel P2PRUNB numbers



# Annex A

## 33.1.4.2 Type 1 and Type 2 channel requirement

Type 1 and Type 2 operation requires that the resistance unbalance shall be 3 % or less. Resistance unbalance is a measure of the difference between the two conductors of a twisted pair in the 100  $\Omega$  balanced cabling system. Resistance unbalance is defined as in Equation (33–1):

$$\left\{ \frac{(R_{\max} - R_{\min})}{(R_{\max} + R_{\min})} \times 100 \right\} \% \quad (33-1)$$

where

$R_{\max}$  is the resistance of the channel conductor with the highest resistance  
 $R_{\min}$  is the resistance of the channel conductor with the lowest resistance

- The way channel pair (the differences between two wires in a pair) resistance unbalance was defined.

# Annex A1

- Inputs from Pete Johnson:
- 3% DC Unbalance comes from ISO / IEC.
- **TIA 568** has DC Unbalance specified as 5% using **ASTM D 4566** definition of DC Unbalance that is different from that used by ISO.
- The ASTM method is  $\% \text{ Runbal} = 100 * (\text{Max R} - \text{Min R}) / \text{Min R}$
- 
- Yair Response (to be discussed by the group) next (3<sup>rd</sup> meeting):
  - Since cables vendor wants to meet "all standards" they meets the 2% cable. System and component vendors count on the 3% channel.
  - Our IEEE POE standard is counting on the 3% max.
  - The ASTM method that calculates  $\% \text{ Runbal} = 100 * (\text{Max R} - \text{Min R}) / \text{Min R}$  is familiar but has no practical physical meaning related to current unbalance that we can use e.g. for transformers. The equation that we are using is a derivation of the current unbalance definition and rationale.
  - As a result, I believe we should stay with current 3% pair resistance unbalance and our IEEE equation for Unbalance.
- Pete agrees to this response.

# Annex B: What is more important P2PRUNB or Current increase/pair due to at worst case conditions?

- To discuss the advantages that PD constant Power Sink allows us.
- Background material for considering:
  - Worst case End to End Channel Pair to Pair Channel Resistance Unbalance is at short cable (<100m).
  - At short cables PD voltage is higher that at 100m channel length and pair/port current is lower
  - Not only that the port current is lower, it is <600mA for Type 3 systems below TBD channel length.
    - **As a result, P2PCRUNB max is not an issue.**
  - At 100m the P2PCRUNB is much smaller than at short channel
  - Resulting with less significant contribution to I<sub>bias</sub> due to P2PCRUNB and as a result to OCL.
  - **This approach was validated in:**  
[http://grouper.ieee.org/groups/802/3/4PPOE/public/jul13/darshan\\_2\\_0713.pdf](http://grouper.ieee.org/groups/802/3/4PPOE/public/jul13/darshan_2_0713.pdf) and requires further investigation for completing this work.

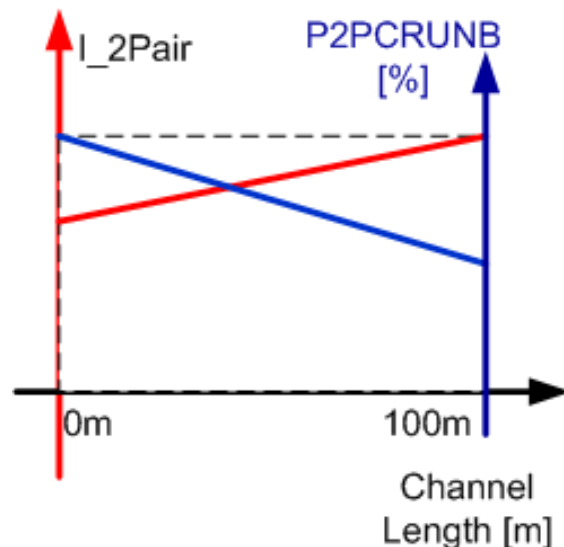

**Answer:**

In order to answer the question we need to check both data sets 1 and 2 in the worst case data base.

**Illustration of the behavior.**

(The curve is not linear. It is just describing the trend.)

**Source:**

1. See link above, from July 2013.
2. Adhoc meeting #2, February 24, 2014.

# Annex C1: Why we care for P2P resistance unbalance parameters

- In 4P system:
- If  $P2PRUNB > 0$  the PD current over each 2P will not be the same.
  - 51W PD with maximum total current of 1.2A, the current will split to  $0.6A + 0.18A = 0.78A$  over the 2pairs with minimum resistance and 0.42A with the pair with maximum resistance.
- In general: The pair with the highest current will be:  
 $I_t \cdot (1 + P2PRUNB) / 2$ 
  - This will require to overdesign the magnetics for high P2PRUNB values.
  - Watching limits of connector pins, PCB traces and power components on the DC current path at PSE and PD and overdesign accordingly.
  - So there is interest to have components with lower P2PRUNB along the channel as possible by cost and manufacturability limitations to result with lower End to End Pair to Pair RUNB.

## Annex C2: Why we care for P2P resistance unbalance parameters

- Other concerns were how it will affect on PD minimum available power for a 60W system (two times the 802.3at power). The decision was that for our current data base we can supply 49W for the PD (instead of 51W). See 802.3bt objective.
  - This was done by calculating what will be the power at the PD if we keep maximum 600mA at the pair in order not to cause issues to Type 2 component/ devices that can work with 4P
- Other concern was if P2PRUNB will increase power loss on the cable. We show that now it will not. Moreover we show that if P2PRUNB increased, the power loss is decreased.

$$Trise = 0.5 \cdot N \cdot It^2 \cdot R_{loop\_max} \theta_N \cdot [1 - P2PCRUNB]$$

- See: [http://www.ieee802.org/3/4PPOE/public/nov13/darshan\\_02\\_1113.pdf](http://www.ieee802.org/3/4PPOE/public/nov13/darshan_02_1113.pdf) for more details.

# Annex D1: Calculations of CP2PRUNB with constant power sink model and the effect on transformer bias current.

Equation	Symbol	Units	Channel Length	
			1m	100m
End to End Pair to Pair Channel Resistance Unbalance: $CP2PRUNB = \frac{\sum R_{max} - \sum R_{min}}{\sum R_{max} + \sum R_{min}}$	CP2PRUB	-	0.26	0.112
	I	A	1.02	1.2
	I/2	A	0.51	0.6
I*CP2PRUNB	DI	A	0.2652	0.1344
I*CP2PRUNB/2	DI/2	A	0.1326	0.0672
I*(1+CP2PRUNB)/2	I <sub>max</sub> =(I+di)/2	A	0.643	0.667
I*(1-CP2PRUNB)/2	I <sub>min</sub> =(I-di)/2	A	0.377	0.533
I <sub>bias</sub> =3%*I <sub>max</sub> /2		A	0.0193	0.02
Sanity Check	I	A	1.02	1.2
Effect on I <sub>bias</sub> of transformer: 3%*(I <sub>max</sub> -0.6)/2	d(I <sub>bias</sub> )	mA	0.639	1.008

# Annex D2: Affecting parameters on Transformer Ibias

- PSE Rsense and Rdson are out of the loop for pair unbalance
  - They affect only on P2P unbalance
    - Which affect Iport (increase or decrease) which affect Ibias by  $3\% * (Iport\_max - Iport\_nominal)$
- How to reduce Ibias?
  - Adding Rballast on transformers reduces Ibias directly
  - Defining minimum cable length reduces P2PRUNB\_max. The effect on Ibias is  $3\% * (Iport\_max - Iport\_nominal)$ .
  - Adding in PD ballast resistors (cost effective in PD and not in PSE)
    - May not be needed for PD power below TBD.
  - Using match diode bridges, significantly reduces P2PRUNB and as a result, the current unbalance

# Annex E1 – Connector and Cabling standard data

- Summary of resistivity and resistance unbalance (Source Wayne Larsen)
- specifications in TIA cabling standards
- Resistivity of cable and “cordage” from cabling standards
- – Cable DC resistance is 9.38 Ohms / 100 meters, ANSI/TIA-568-C.2, 6.4.1, page 58. Cat 5e, 6, and 6A are all the same.
- – Cordage DC resistance is 14 Ohms / 100 meters, ‘568-C.2, 6.6.1,page 74. Cat 5e, 6, and 6A are all the same.
- – Cable and cordage resistance unbalance with a pair is 2.5 % per IEC 61156-1, ‘568-C.2-1 6.4.2 page 58. All categories are the same.
- – Cable and cordage resistance unbalance between pairs is not specified, but has been studied and found to be less than 5 %.
- – Connectors are allowed 200 mOhms resistance and 50 mOhms resistance unbalance between any conductor. They actually have much less resistance.
- Yair notes:
- These values are maximum values, pre PoE standard.
- There are no specifications for minimum values as needed for P2P unbalance analysis. As a result, to cover both angles of P2PRUNB at short and long channel, maximum 12.5Ω channel was used and channel with horizontal cable resistivity of 0.066 Ω/m was used.
- As for connectors: less than 0.06 Ω connector resistance was used. See worst case data base for details.



# Annex E2 – Connectors terms.

## ■ Source Yakov Belopolsky / BEL

- The term used in the connector industry is LLCR (Low Level Contact Resistance)- Bulk  $R_{LLCR-B}$
- Low Level Contact Resistance (LLCR-Bulk ) consists of four components
  - Plug Conductor Resistance  $R_{CR}$
  - Plug Blade/Conductor Contact Resistance  $R_{PBCR}$
  - Plug Blade/Jack Wire Contact Resistance or TRUE LLCR  $R_{CRTRUE}$
  - Jack Wire Resistance  $R_{JWR}$
- $R_{LLCR-B} = R_{CR} + R_{PBCR} + R_{CRTRUE} + R_{JWR}$
- However, it is easy to measure and subtract  $(R_{CR} + R_{PBCR})$  from the Bulk so many connector vendors use the Contact resistance  $(R_{CRTRUE} + R_{JWR})$
- **A typical differential between two types measurements is less than 20 milliohm**
- The reason is that the  $(R_{CRTRUE} + R_{JWR})$  is affected by environmental exposure and defines the quality of the connector design separately from the plug blade termination quality

# Annex E3: Connector data from vendors datasheet

Source: Microsemi

	Vendor	“Contact resistance” per datasheet
<b>CAT6</b>	CSAK	30 miliOhm max ,Jack only <sup>1</sup>
<b>CAT6</b>	CTK	35 miliOhm max ,Jack only <sup>1</sup>
<b>CAT6</b>	CSCE	30 miliOhm max ,Jack only <sup>1</sup>

1. It is per datasheet so actual values are lower.

# Annex E4 - Connector data – Source BEL

[http://www.ieee802.org/3/at/public/2006/07/belopolsky\\_1\\_0706.pdf](http://www.ieee802.org/3/at/public/2006/07/belopolsky_1_0706.pdf) slide 22.

**30miliOhm connector resistance shown by BEL**

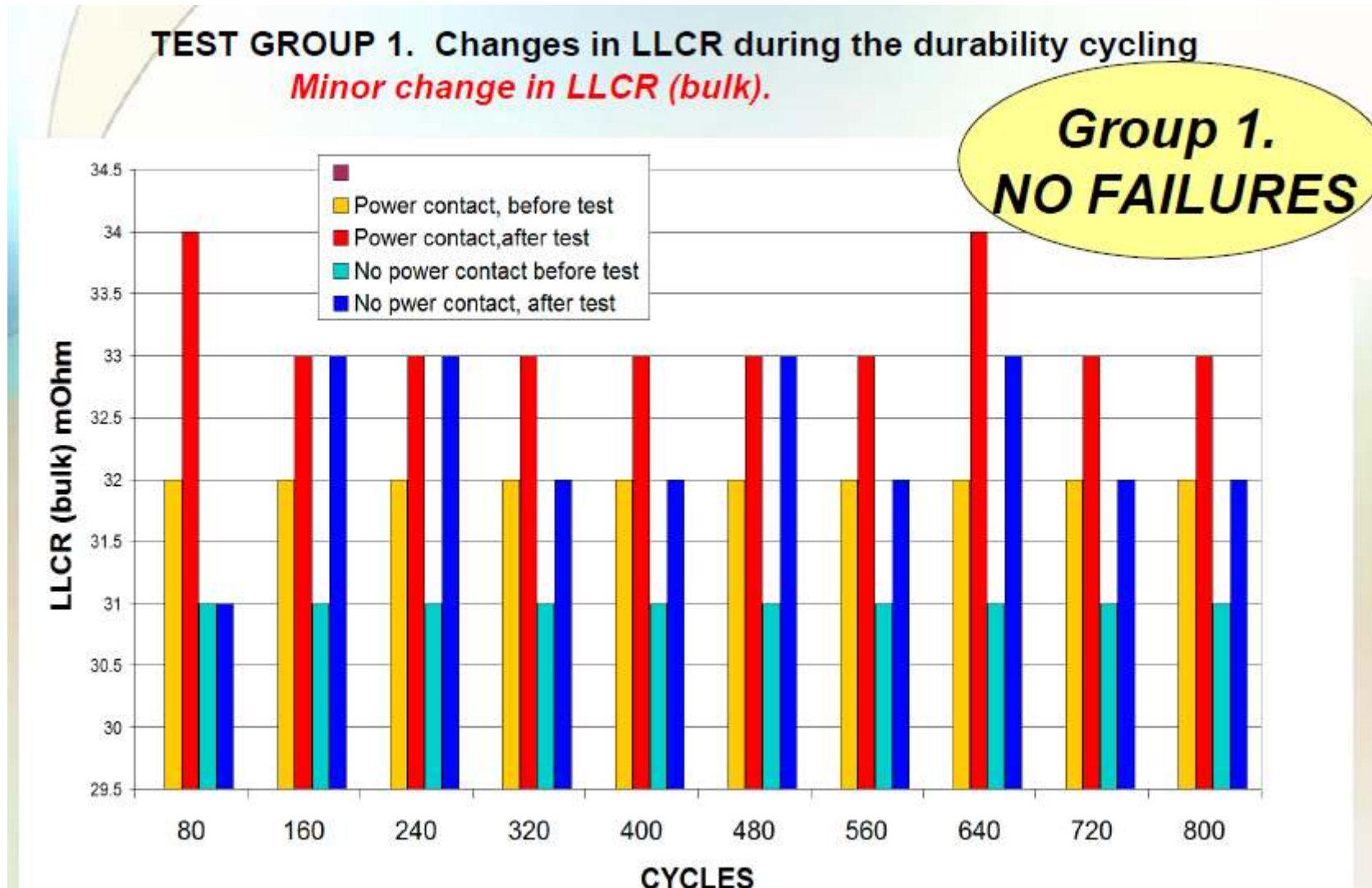

End to End Channel Pair To Pair Resistance Imbalance Ad Hoc rev 010. Yair Darshan, June 2014

# Annex E5: Connectors test data

- Source: Microsemi
- Each number in the table is the average resistance of all pins from end to end (Plug and Jack) for each connector.

Connector #	Vendor A	Vendor B	Vendor C	Vendor D	
	CAT6	CAT6	CAT6A	CAT6A	
1	45	43	39	42	45
2	43	43	40	49	46
3	48	42	40	40	39
4	48	46	42	39	44
5	43	45	39	38	47
6	46	39	43	50	44
7	45	42	39	38	43
8	49	46	42	41	44
9	46	45	39	44	45
10	42	45		51	44
11	43	46		44	43
12	43	43		50	39
13		46		54	40
14		42		39	47
15		46		55	42
16		46		51	48

	Vendor A	Vendor B	Vendor C	Vendor D
Average	45.08	44.06	40.33	44.53
Max	49	46	43	55
min	42	39	39	38
Rdiff	7	7	4	17

Average connector resistance	43.50
Max	55
Min	38
Rdiff	17

- All connector resistance: 55miliΩ max.**
  - Vendors approve 60miliΩ max.
  - There are high quality connector that get to 30miliΩ.
  - The average resistance of these samples: 43.5miliΩ
- Additional Information (not shown from the tables attached):**
  - Within a connector, **pair to pair resistance difference** ≤ 20miliΩ was confirmed.
  - Most results were below 15miliΩ

# Annex E6: Connectors test data

[http://www.vtiinstruments.com/Catalog/Technotes/RJ-45\\_Excels\\_For\\_Stria\\_Gage\\_Connection.pdf](http://www.vtiinstruments.com/Catalog/Technotes/RJ-45_Excels_For_Stria_Gage_Connection.pdf)

---

- See above link page 12.
- 45miliOhm connector resistance of 40 connector samples.
- See page 13 at the above ling for connector resistance over temperature

# Annex F – End to End P2P Resistance Unbalance Model

General Channel Model and its components that we have used.

Adhoc: OK

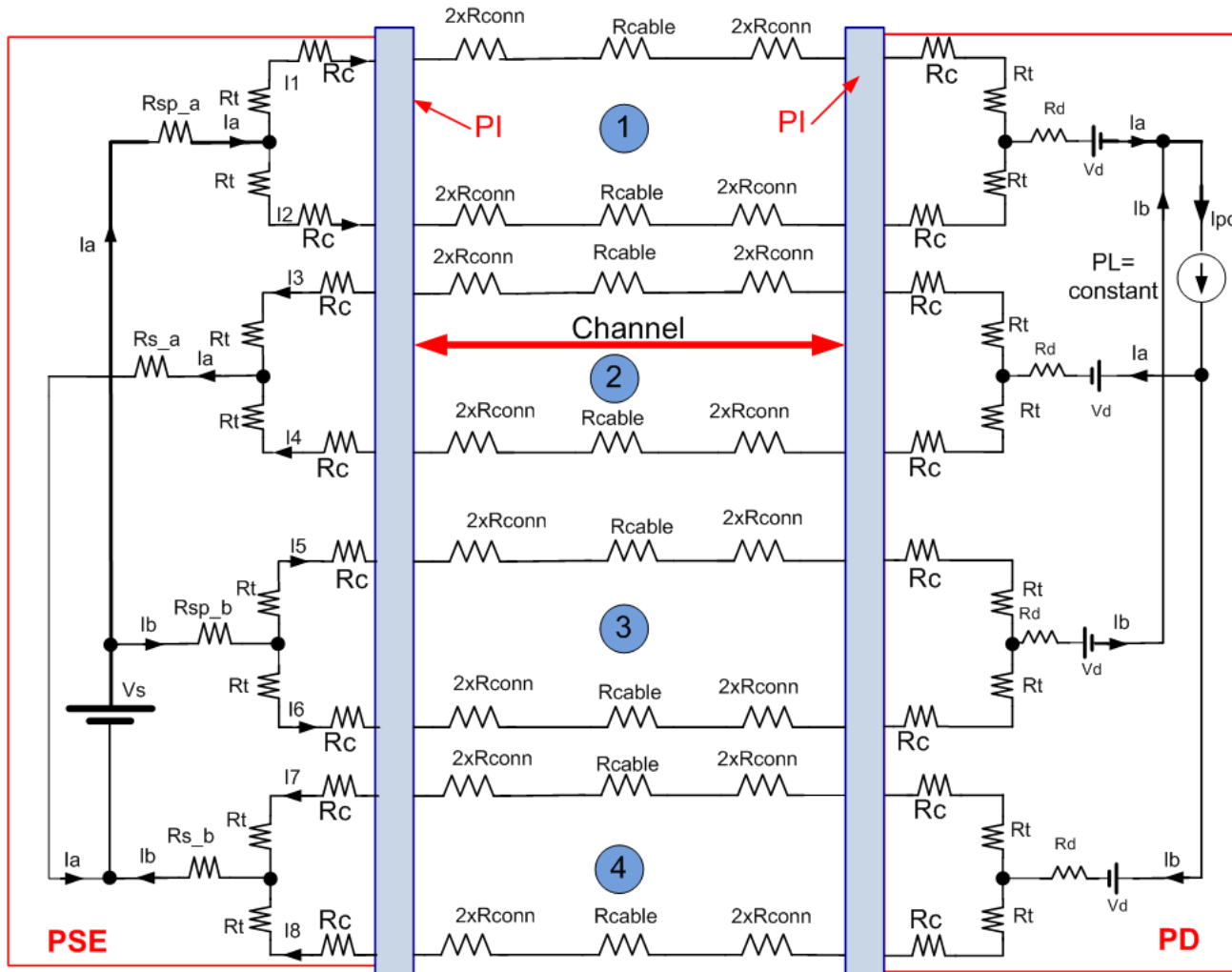

## Notes for the general Model:

1. Adding resistors on positive path for general model ( $R_{sp\_a}$  and  $R_{sp\_b}$ ). It can be set to zero or  $>zero$  pending the case being investigated.
2. Adding equipment connectors per Wayne's comment. So total end to end channel connectors is 6 max.
3. The formal channel definition is marked in red arrow.
4. Our work addresses also the internal application resistance of known components that are used

# Annex J1-Acronyms used in the ad-hoc activity

Adhoc: OK

- **(1) Pair resistance unbalance** : Is the resistance unbalance between two wires in the same pair as specified by IEEE802.3 and other standards. This is 2% for cable and 3% maximum for the channel. Channel is a 4 connector model (cables and connector only).
- **(2) Pair to Pair resistance unbalance**: is the resistance unbalance between two wires of the same pair connected in parallel to another two wires of other pair connected in parallel. It is 5% for a cable.

(The resistance of the two wires of the pair is know also as the common mode resistance of the pair)

- **(3) End to End channel pair to pair resistance unbalance** it is the 26.2% (TBD) worst case calculation on a worst case data base that we have generated. The 26.2% (TBD) was calculated at 20degC. The channel is including components at PSE PI and PD PI that affects the whole end to end channel.
- **(4) PSE PI Pair to Pair resistance unbalance** is the P2P DC Common Mode PSE Output Resistance Unbalance measured at the PSE PI and include PI interface circuitry such RDSON, Current sense resistor, equipment connector, magnetic winding resistance. This is included in the " end to end channel resistance unbalance" and need to be extracted from it to be separate definition for PSE PI P2PRUNB.
- (4.1) PSI PI Pair to Pair voltage difference is the P2P DC Common Mode PSE Output Voltage Difference measured at the PSE PI under TBD conditions.

# Annex J2-Acronyms used in the ad-hoc activity

Adhoc: OK

- **(5) PD PI Pair to Pair resistance unbalance** is the P2P DC Common Mode PD input Resistance Unbalance measured at the PD PI and include PI interface circuitry such Diode bridge voltage offset and dynamic resistance, equipment connector, magnetic winding resistance. This is included in the "end to end channel resistance unbalance" and need to be extracted from it to be separate definition for PD PI P2PRUNB.
- **(5.1) PD PI Pair to Pair voltage difference** is the P2P DC Common Mode PD input Voltage Difference measured at the PD PI under TBD conditions.
- **(6) Channel Pair to Pair resistance unbalance** is the P2P resistance unbalance of the cables and 4 connector model. This need to be excreted from the " end to end channel resistance unbalance" and specified separately.
- So (PSE PI +Channel + PD PI)p2prunb all together is 26.2% (TBD).
- Items 4,5 and 6 will be specified in the standard, (item 2 is covered by item 6).
- Meeting #4: Adhoc response: ok. Meeting #5: To discuss changes in RED. Done.





Last meeting material

# Meeting # 6 Attendees (Thursday May 15, 2014)

- Gaoling Zou / Maxim
- Christian BEIA / ST
- David Tremblay / HP
- Yair Darshan / Microsemi
- George Zimmerman/ CME Consulting, Affiliations: Commscope & Aquantia
- Peter Johnson / Sifos
- Rick Frosch / Phihong
- Yan Zhuang / Huawei
- Larsen, Wayne / Commscope
- Jeff Heath / LT
- Dave Dwelley / LT
- Fred Schindler / Seen Simply
- David Abramson / TI
- Rimboim Pavlik / Microsemi
- Victor Renteria / BEL
- Dave Dwelley / LT
- Heat Stuart / LT
- Sterling Vaden /
- Fred Dawson / duPont
- Shahar Feldman / Microsemi
- Wendt, Matthias / Philips
- Picard Jean / TI
- Lennart Yseboodt / Philips

# Adhoc report May 15, 2014 Norfolk VA.

---

- 18 attendees
- Topics discussed:
  - How to handle PSE PI, PD PI Pair to Pair unbalance parameters and Channel P2RUNB as function of temperature?
    - Adhoc response:
    - Use PSE PI, PD PI pair to pair Unbalance parameters and Channel P2PRUNB that was calculated at 20°C (or pick a number at other temperature).
    - Set it as the number to meet without saying at what temperature it is.
    - Vendors will have to assure that they meet it at their operating temperature range spec.
    - How they will do it, we don't care. The rest is per 33.7.7.
  - Two motions to specify Channel P2PRUNB and its base line text
    - Adhoc proposed the following two motions:
- Motion #1:
  - Move that 802.3bt specify the Channel Pair to Pair resistance unbalance for operating 4P systems

## Motion #2. Motion to add the following text to clause 33 after 33.1.4.2.

- **33.1.4.3 Type 3 and Type 4 Channel Requirement for Pair to Pair Resistance unbalance**
- 4P pair operation requires the specification of resistance unbalance between each two pairs of the channel, not greater than 200 milliOhms or **6%(TBD)** which ever is greater. Resistance unbalance between the channel pairs is a measure of the difference of resistance of the common mode pairs of conductors used for power delivery. Channel pair to pair resistance unbalance is defined by equation 33-1.1:

- $$\left\{ \frac{\left( R_{ch\_max} - R_{ch\_min} \right)}{\left( R_{ch\_max} + R_{ch\_min} \right)} \times 100 \right\} \% \quad 33-1.1$$

Where:

Rch\_max is the sum of channel pair elements with highest common mode resistance.

Rch\_min is the sum of channel pair elements with lowest common mode resistance

Common mode resistance is the resistance of the two wires in a pair (including connectors), connected in parallel.

# Open issues - 1

---

- Proposal for motion for specifying PSE PI Pair to Pair Output resistance unbalance and pair to pair output voltage unbalance during Power ON state for operating 4P systems.
  - Waiting for completion of test model.
  - Test model was presented see Annex E, inputs were received:
    - To consider changing voltage source load with current load
  
- What is the PD load current on Mode A and Mode B in which below that current, P2P requirements can be ignored.
  - Responses:
    - (1) Below 25W no need for P2PRUNB requirements
    - (2) We may care below 25W to optimize transformers for 4W loads
    - (3) *Response (2) checked, negligible difference between Type 1 and 2, probably no incentive for special magnetics for below Type 1 power. See annex D shown in previous meeting.*

# Open issues - 2

---

- Worst case Data Base
  - Comments:
    - Replace connector contact resistor with Connector resistance.
    - Yair to send Jeff connector test results.
    - To check results with connector resistance per standard with  $R_{cmax}=200\text{miliOhm}$  and  $50\text{miliOhms}$  difference.
      - Response: No value. We are looking for worse case.
    - Connector resistance:  $10\text{miliom}$  minimum –  $60\text{miliohm}$  max.
      - Sterling to supply information for connector resistivity.
  - To check CAT6A cable resistance per the actual cable length
    - Cabling spec requires CAT6A resistance for 100m will be as defined for CAT5/e. In reality it will be lower for AWG23. To verify.
  - Diode bridges are worst case components compared to no diode or active diode bridge.
  - Clarify title of the two column use cases

# Open issues - 3

---

- Test models for PD and baseline text:
    - Not started yet.
-

# Adhoc meeting May 15, 2014, Norfolk VA

---

- Agenda
- Concept of how to address P2P unbalance as function of temperature (20 minutes)
- Discussing proposed motions from the adhoc (30 minutes)
- The PD power limits in which P2P requirements are not relevant.
- New Presentations? (10 minutes)



# Adhoc report

-1

- 5 adhoc meetings since March 2014 meeting
- 15 attendees in average each meeting
- See adhoc recommendations for:
  - How to handle temperature: See slide 19.
  - Discussion and straw poll slides 14-18.
- Agreement on which parameters need to be defined in the standard (PSE PI, PD PI and Channel P2P unbalance related parameters: Slide 8. Discussion slides 7-8.
- Agreement on terms and acronyms to be used in adhoc discussions: slides 7-8
- Motions drafts are ready for:
  - Channel P2P Resistance Unbalance are ready: Slides 10 and 11
  - PSE PI P2PRUNB and PSE P2P Voltage Difference: Slide 12
- Agreement on 4 channel length scenario to be calculate worst-case: Slide 24-25
  - Need to specify conditions for compliance based on cabling performance suggested by Wayne. Need farther discussion (9.38 ohms and 14 ohms data on slide 25)

- Worst Case data base was updated (2,4,6 connectors, different channel lengths: Slide 27).
  - Simulation results: Slide 28-31.
  - Conclusions: Slide 32 to be discussed.
  
- Motions need to be closed soon
  - PD PI P2P unbalance requirements
  - In which temperature we will calculate spec P2P unbalance parameters? See slide 21
  
- Open issues
  - What is the PD power/current that below it, P2P requirements are not important?
    - Good discussions. Yair & Christian (and Ken?) will work on proposal.
  
- More relevant material and discussions on the rest of the slides

# Meeting # 5 Attendees (Thursday May 8, 2014)

---

- Ronald Tellas / Panduit
- Gaoling Zou / Maxim
- Brian Buckmeier / BEL
- Christian BEIA / ST
- Steinke, Stephan / Molex
- Koussalya Balasubramanian / Cisco
- David Tremblay / HP
- Yair Darshan / Microsemi
- George Zimmerman/ CME Consulting,  
Affiliations: Commscope & Aquantia
- Ken Bennett / Sifos
- Rick Frosch / Pihong
- Yan Zhuang / Huawei

## Meeting # 3 and # 4 Attendees (April 24, May 1, 2014)

### Meeting # 3

- Yan Zhuang / Huawei
- Ronald Tellas / Panduit
- Larsen, Wayne / Commscope
- Jeff Heath / LT
- Brian Buckmeier / BEL
- Rick Frosch / Pihong
- Christian BEIA / ST
- Leonard Stencil / Bourns
- Fred Schindler / Seen Simply
- Koussalya Balasubramanian / Cisco
- David Tremblay / HP
- David Abramson / TI
- Rimboim Pavlik / Microsemi
- Yair Darshan / Microsemi
- Ken Bennett / Sifos
- Victor Renteria / BEL
- George Zimmerman/ CME Consulting,  
Affiliations: Commscope & Aquantia

### Meeting # 4

- Steinke, Stephan / Molex
- Gaoling Zou / Maxim
- Jean Picard / TI
- Larsen, Wayne / Commscope
- Jeff Heath / LT
- Brian Buckmeier / BEL
- Christian BEIA / ST
- Koussalya Balasubramanian /  
Cisco
- David Abramson / TI
- Yair Darshan / Microsemi
- Ken Bennett / Sifos
- Wendt, Matthias / Philips

# Proposed Agenda, Meeting #4, May 1, 2014.

---

- Introduction
- Planes for today, May 8, 2014
  - Introduction (1 minute)
  - Approving slide 6 and 7 updates (5 minutes)
  - Finalizing Motion 1 and/or 1.1. (10 minutes)
  - Approving slide 19 proposal (temperature issue) (10 minutes)
  - Christian Presentation – Data results from updated data base model (10m)
  - Discussion on other proposed motions. (10 minutes)
- Discuss proposed baseline text (Moved to IEEE meeting next week)

# Introduction

---

- The purpose of this ad-hoc is to recommend the Task-Force for what is needed to specify the channel pair to pair resistance unbalance while considering not only the formal channel components (Cable and Connector) but also the Power Interface (PI) components at both ends of the 4P PoE system.
- Patent Policy
  - Please read the Patent Policy slides at <http://www.ieee802.org/3/patent.html> prior the meeting.

# Acronyms used in the ad-hoc activity (1)

Adhoc: OK

- **(1) Pair resistance unbalance** : Is the resistance unbalance between two wires in the same pair as specified by IEEE802.3 and other standards. This is 2% for cable and 3% maximum for the channel. Channel is a 4 connector model (cables and connector only).
- **(2) Pair to Pair resistance unbalance**: is the resistance unbalance between two wires of the same pair connected in parallel to another two wires of other pair connected in parallel. It is 5% for a cable.

(The resistance of the two wires of the pair is known also as the common mode resistance of the pair)

- **(3) End to End channel pair to pair resistance unbalance** it is the 26.2% (TBD) worst case calculation on a worst case data base that we have generated. The 26.2% (TBD) was calculated at 20degC. The channel is including components at PSE PI and PD PI that affects the whole end to end channel.
- **(4) PSE PI Pair to Pair resistance unbalance** is the P2P DC Common Mode PSE Output Resistance Unbalance measured at the PSE PI and include PI interface circuitry such RDSON, Current sense resistor, equipment connector, magnetic winding resistance. This is included in the " end to end channel resistance unbalance" and need to be extracted from it to be separate definition for PSE PI P2PRUNB.
- (4.1) PSI PI Pair to Pair voltage difference is the P2P DC Common Mode PSE Output Voltage Difference measured at the PSE PI under TBD conditions.

# Acronyms used in the ad-hoc activity (2)

Adhoc: OK

- **(5) PD PI Pair to Pair resistance unbalance** is the P2P DC Common Mode PD input Resistance Unbalance measured at the PD PI and include PI interface circuitry such Diode bridge voltage offset and dynamic resistance, equipment connector, magnetic winding resistance. This is included in the "end to end channel resistance unbalance" and need to be extracted from it to be separate definition for PD PI P2PRUNB.
- **(5.1) PD PI Pair to Pair voltage difference** is the P2P DC Common Mode PD input Voltage Difference measured at the PD PI under TBD conditions.
- **(6) Channel Pair to Pair resistance unbalance** is the P2P resistance unbalance of the cables and 4 connector model. This need to be excreted from the " end to end channel resistance unbalance" and specified separately.
- So (PSE PI +Channel + PD PI)p2prunb all together is 26.2% (TBD).
- Items 4,5 and 6 will be specified in the standard, (item 2 is covered by item 6).
- Meeting #4: Adhoc response: ok. Meeting #5: To discuss changes in RED. Done.



# Proposal text for Motion (1) (From meeting #4).

## See next slides: Breaking to separate motions

- Move that 802.3bt specify the following parameters for operating 4P systems during Power ON state:

a) PSE PI Pair to Pair resistance unbalance and pair to pair voltage unbalance. (Adhoc-done)

(The model is the same, two voltage sources V1, V2 or single voltage source in the model is implementation issue. What we care is the voltage difference measured at the PI ( $\max|V1-V2|$ ). (Group response: ??)

b1) Specify test circuit/procedure for specifying PD PI Pair to Pair resistance unbalance (For this motion, a2 on separate motion after doing some work).

b2) PD PI Pair to Pair resistance unbalance and voltage unbalance.

***(For next meeting to present PD test circuit for PD PI P2PRUNB)***

c) Channel Pair to Pair resistance unbalance (Adhoc-done)

The above parameters will be analyzed and specified based on the End to End Channel Pair to Pair Resistance Unbalance model as proposed by the ad-hoc. See slide N, link..

A.I.: Jeff, Jean and interested parties for closing item b. Please prepare presentation with your comments and Suggested remedies to be discuss over the reflector and we help with our inputs.

# Proposal text for Motion (1)

Adhoc: OK

- Motion to require that the 802.3bt Task force will specify the requirements for **Channel Pair to Pair resistance unbalance** for operating 4P systems.
- **Meeting #5:Adhoc-done.**
- (Better language suggested by George, send during the meeting)
- **Move that 802.3bt specify the Channel Pair to Pair resistance unbalance for operating 4P systems**
- **Adhoc ok: 15/5/2014**

Adhoc: OK  
15/4/2014

Motion to add the following text to clause 33 after 33.1.4.2.

- **33.1.4.3 Type 3 and Type 4 Channel Requirement for Pair to Pair Resistance unbalance**
- 4P pair operation requires the specification of resistance unbalance between each two pairs of the channel, not greater than 200 milliOhms or **6%(TBD)** which ever is greater. Resistance unbalance between the channel pairs is a measure of the difference of resistance of the common mode pairs of conductors used for power delivery. Channel pair to pair resistance unbalance is defined by equation 33-1.1:

33-1.1

- $$\left\{ \frac{(R_{ch\_max} - R_{ch\_min})}{(R_{ch\_max} + R_{ch\_min})} \times 100 \right\} \%$$

- Where
- Rch\_max is the sum of channel pair elements with highest common mode resistance.
- Rch\_min is the sum of channel pair elements with lowest common mode resistance
- Common mode resistance is the resistance of the two wires in a pair (including connectors), connected in parallel.

# Proposal text for Motion (2)

---

- Move that 802.3bt specify PSE PI Pair to Pair Output resistance unbalance and pair to pair output voltage unbalance during Power ON state for operating 4P systems.

-----  
The above was item a in meeting #4.

Adhoc-done

-----

(The model is the same, two voltage sources V1, V2 or single voltage source in the model is implementation issue. What we care is the voltage difference measured at the PI ( $\max|V1-V2|$ ). (Group response: ??)

The above parameters will be analyzed and specified based on the End to End Channel Pair to Pair Resistance Unbalance model as proposed by the ad-hoc. [See slide N, link..](#)

A.I.: Jeff, Jean and interested parties for closing item b. Please prepare presentation with your comments and Suggested remedies to be discuss over the reflector and we help with our inputs.

# Proposal text for Motion (4)

Motion to add the following text to informative section.

## **Cable Requirement for Pair to Pair Resistance unbalance**

4 pair operation, requires the additional specification of resistance unbalance between each two pairs of the cable. The cable pair to pair resistance unbalance was studied and found to be 5% or less. Resistance unbalance between the pairs is a measure of the difference of resistance of the common mode pairs of conductors used for power delivery. Cable pair to pair resistance unbalance is defined by equation 33-1.1:

$$\left\{ \frac{(R_{cm\_max} - R_{cm\_min})}{(R_{cm\_max} + R_{cm\_min})} \times 100 \right\} \% \quad 33-1.1$$

where

$R_{cm\_max}$  is the pair with highest common mode resistance.

$R_{cm\_min}$  is the pair with lowest common mode resistance.

Common mode resistance is the resistance of the two wires in a pair, connected in parallel.

# Issues to be discussed in #3/4 meeting 24/April/ May 1, 2014 (1)

- How to address temperature effect on P2PCRUNB?
  - We agree that we don't care of high temperature since it works for us (high temperature higher resistance lower P2PCRUNB)
  - So the question is narrowed to below room temperature (20-24°C)?.

Yair response:

1. All parameters in the standard are tested for compliance at room temperature.

System and component vendors are responsible to design the parts/system to meet their spec over their spec of operating temperature range.

1. We can study and supply the guidelines/equations in informative annex to help decide what to do in temperatures below room temperature but it can't be part of the standard. (not high priority)

Please see what IEEE802.3-2012 says about this topic:

### **33.7.7 Temperature and humidity**

The PD and PSE powered cabling link segment is expected to operate over a reasonable range of environmental conditions related to temperature, humidity, and physical handling. Specific requirements and values for these parameters are beyond the scope of this standard.

Recommendation: To focus on results at room temperature for the baseline.

Anything else could be:

- a) left for the informative section of the standard
- b) per 33.7.7

Please see what IEEE802.3-2012 says about this topic:

### 33.7.7 Temperature and humidity

The PD and PSE powered cabling link segment is expected to operate over a reasonable range of environmental conditions related to temperature, humidity, and physical handling. Specific requirements and values for these parameters are beyond the scope of this standard.

-----

Yair's Recommendation: To focus on results at room temperature for the baseline.

Anything else could be:

- a) left for the informative section of the standard
- b) per 33.7.7

--- DISCUSSION -----

(1) Yair: Define at 25degC and the rest put in the informative section

(2) Jeff/Wayne: Mandatory section we need to define at 25degC and (-TBD)

(3) Jeff: To define one number which is the worst case and will include low temperature (similar to a worst case of insertion loss at high temp.)

Yair: (May 1, 2014) During reflector discussion we saw that insertion loss is define at 20degC and at higher temperature derating is allowed by using shorter cable which means that insertion loss is not specified for worst case operating temperature (ANSI/TIA 568-C.2 Annex G Clause 6.4.7.

-Christian: Testing cost issues in (2)

-Ad hoc agree to vote by mail and result will be our recommendation to task force to move forward.

**Straw poll material was sent. See details next slides.**

# Options for CP2PRUNB vs Operating temperature

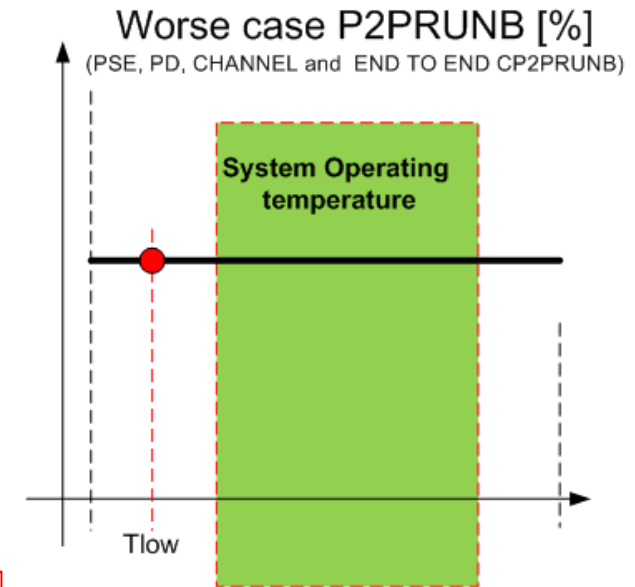
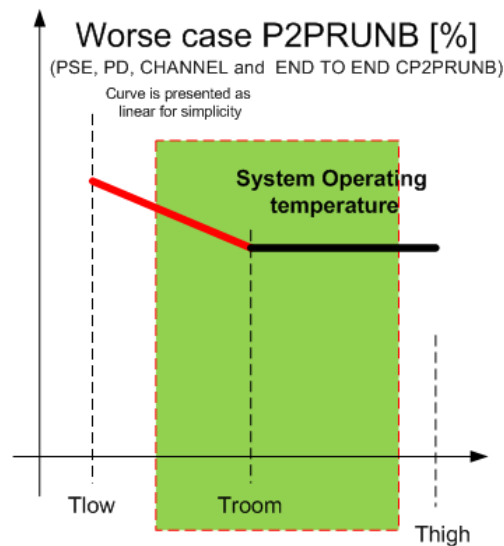
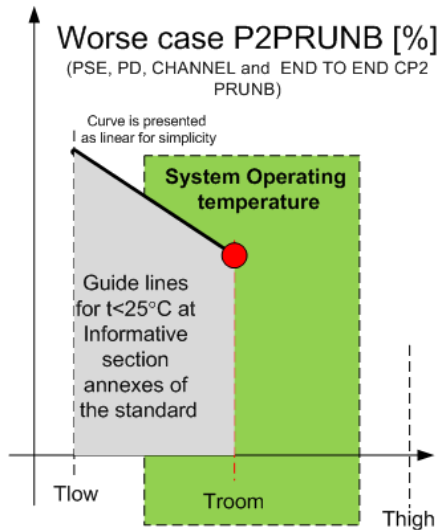

- Option 1
- Defining single point at e.g. Troom=20°C and:
- (a) add information for  $T < T_{room}$  at the informative section **and/or**
- (b) follow Clause 33.7.7
- No Over Design since system vendor responsible to design their system to meet requirements.
- It may increase interoperability concerns???. This concern is valid in all options whenever there is no single worst case number that covers Tlow of 100% of use cases.
  - The remedy for it is specify the requirement and it is up to box designer to meet it over its operating temperature range.

- Option 2
- Defining curve from Tlow to Troom
- Tlow need to cover most of applications known to us.
- Prevents over design. (Allow system vendor to design for its operating temperature range)
- Tlow need to be investigated
- See interoperability concerns discussion in option 1

- Option 3
- Defining single point at Tlow which will be single worst case point.
- Tlow need to cover most of the applications min. temperature.
- This option may be overdesign for equipment with  $T > T_{low}$ . (To investigate)
- Equipment that need to work at  $T < T_{low}$  shall follow Clause 33.7.7
- See interoperability concerns discussion in option 1



# Straw Poll Results

Adhoc: OK

- Select one option only.
- If possible, add rational for your selection, any concerns etc., new suggestions in the notes column.

Name	Options			Notes
	1	2	3	
Yair Darshan / Microsemi	x			Without having the informative part and using clause 33.7.7 instead (Option 1b or name it option 4)
Fred Schindler / Seen Simply			x	
Ken Bennett / Sifos	x			
Yseboodt, Lennart / Philips	x			
Jeff Heat / LT				Accept suggested proposal for option 4 (see mail) which is option 1b (to ask for email confirmation).
Wendt, Matthias / Philips	x			
Dave Dwelley / LT	x			
Rimboim Pavlik / MSCC	x			
Christian Beia / ST	x			Without having the informative part and using clause 33.7.7 instead (Option 1b or name it option 4)
Belopolsky Yakov / BEL	x			
Gaoling Zou / Maxim	x			

Note: **Option 4** language from reflector email exchange (short summary): "use the P2PRUNB for PSE, PD and Channel number that was calculated (total sum=26.2%(TBD)) at room temperature (or pick number at other temperature), set it as THE number to meet without saying at what temperature it is, and vendors will have to assure that they meet it at their operating temperature range spec. How they will do it, we don't care." The rest is per 33.7.7. This option is covered by 1b.

- Results of the straw poll
- 9 for option 1 (7 for 1a or 1b, 2 for 1b)
- 1 for option 3
- 1 for 1b ?? (waiting for confirmation)
  
- Additional information:
- Base on reflector discussion it is summarized to:
  - Use the P2PRUNB for PSE, PD and Channel number that was calculating (total sum=26.2%) at room temperature (or pick number at other temperature), set it as THE number to meet without saying at what temperature it is, and vendors will have to assure that they meet it at their operating temperature range spec. How they will do it, we don't care." The rest is per 33.7.7.
  - This summary is covered by options 1b and 3.  
(Option 1 says room temperature or other temperature
  - Option 3 says lower temperature than room temperature)

# Ad-hoc proposal for the Task force

Adhoc: OK

- To follow the following proposed concept:
- Use PSE PI, PD PI and Channel UNB parameters that was calculated 20°C (or pick a number at other temperature).
- Set it as the number to meet without saying at what temperature it is.
- Vendors will have to assure that they meet it at their operating temperature range spec.
- How they will do it, we don't care. The rest is per 33.7.7.
- **Add accepts this proposal. May 15, 2014, Norfolk VA.**
  
- Note: Channel P2PUNB is not affected by temperature is fixed
  
- **Ad-hoc response: Agree.**
- **Next question will be, OK, what is that temperature p**

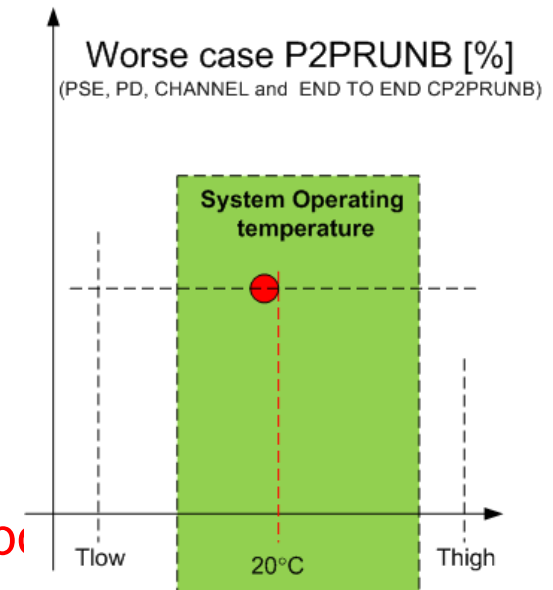

## Next question will be, OK, what is that temperature point?

### ■ Questions

- Is it correct to assume that for Environment A all system parts (Switch, PSE , PD cabling etc.) are at near room temperature?
- If bad ventilation it will be going up?
- Is there situations that for Environment A temperature will be near zero degC? Or stay around 20°C and above?

### ■ Proposals

- A)  $T = 20^{\circ}\text{C}$
- B)  $T = 0^{\circ}\text{C}$
- C) The Typical minimum temperature at enterprise environment, Environment A or equivalent
- **Ad-hoc response:**
- **Yair: It looks that the answer is not important. If we specify a number. The PSE vendor and PD vendor will have to meet it for the entire system op temperature.**

# Issues to be discussed in #3 meeting April 24, 2014

- We need to define the PD load current on Mode A and Mode B in which below that current, P2P requirements can be ignored.
  - Example: if Mode A requires 350mA and Mode B require 113mA than P2P discussion is not relevant to this case.
- We agree that we need to investigate it and address it.
  - Dave Dwelley made a comment about this issue which I didn't record.
  - Dave please send us your comment about this topic to be recorded and addressed.
  - **No response. Removing this item from the agenda.**
- **Proposals:**
  - (1) For PD total power below 25.5 Watts (that ensures pair current  $<600\text{mA}/\text{pair}$ ), for any pair, meeting Channel Pair to Pair Resistance Unbalance is not required.

**Yair: I agree with it. It helps for low cost PDs.**

**Adhoc response:**
  - (2) For PD total power below TBD Watts that ensures pair current  $<600\text{mA}/\text{pair}$ , for any pair, meeting Channel Pair to Pair Resistance Unbalance is not required.
    - **(To discuss this face to face at May meeting.)**
    - **What is the TBD number ? Next question.**

What is the PD power/current where P2P requirements for a given P2P limit numbers are not changing system/components performance as it was not important for Type 2 systems?

- To be discuss during face to face meeting at Norfolk VA.
- Analytical results showing:
  - $I_{t\_max} = 1.2A - P2PCRUNB * I_t$ . (The decision break point of Type 3 systems)
  - If  $I_t > I_{tmax}$ , CP2PRUNB requirements shall be met for Type 3 and up systems.
  - If  $I_t < I_{tmax}$  for Type 3 system, CP2PRUNB requirements are not required to be met.
- $I_{t\_max}$  s total PD current over all 4 pairs that is the P2PRUNB requirements are not affecting 4P operation similar to that it is not affecting 2P operation.
- Example:  $I_{t\_max} = 1.2A - 0.262 * 1.2A = 0.885A$ .
- 4P PD with a power level that requires maximum 0.885A total on all 4 pairs, doesn't need to be concern by P2P requirements. **To work with adhoc if this is true statement.**

# Issues to be discussed in #3 meeting April 24, 2014

- (1) What is the minimum resistance in the channel that above it, we don't care? In other words, what is the minimum resistance in the PD that makes the diodes, connectors, transformers less important in the total channel P2PRUNB?
- (2) Do we need to specify minimum length?.

Yair Response: we will know the answer based on (1) and running simulations/calculations per Wayne proposal for 4 channel length options.

- What will be minimum  $\Omega/m$  for patch cords?
- Yair: I suggest to use the  $9.38\Omega/100m$  ( $93.8m\Omega/m$  as max value and 5% less as the minimum value since patch cords normally need to be flexible than the horizontal cable so their wire diameter is smaller than horizontal cables such as CAT6A.
- Yair: I remember that Wayne said that the 0.15m channel length option is with  $14\Omega/100m$ .
  - Wayne to confirm.
  - Wayne: What is your opinion to the above proposal?
- **Wayne response: See next slide.**

# Issues to be discussed in #3 meeting April 24, 2014

- **Wayne response:** Thinking about possible use cases, it seems to me it is possible, someone may provide PSE equipment in a rack and PD equipment in the rack unit below it in the same rack. If we agree this is a possible use case, it could be connected by a patch cord 0.15 m long. Patch cords have a de-rated DC resistance requirement of  $14\Omega/100\text{m}$ , as Yair states. In finding the absolute minimum, someone could also use un-de-rated patch cord material.
- In any case, for this use case, I think the DC resistance, and the DC resistance unbalance, of the cabling system, is low enough that the equipment MDI, and other elements of the equipment circuit, will dominate.
- Yair response: Yes, in very short channel the equipment MDI, and other elements of the equipment circuit, will dominate i.e. it will be almost similar to the PSE PI and PD PI P2PRUNB that we agree that we need to define anyway. I will simulate results with 0.15m cable with  $0.14\ \Omega/\text{m}$  when simulation only PSE and PD PIs.
- Group OK. 0.15m minimum. Follow Wayne proposal for 4 different channel length for calculation/analysis.

Adhoc: OK



# Issues to be discussed in #3 meeting April 24, 2014

---

- See inputs from Pete Johnson and Yair Darshan response regarding the method of calculating Runb at Annex A1. (If you disagree send email and we will discuss in next meeting. Other wise we agree to this response)
- Adhoc agrees (no responses, removed from the agenda).
- ----
- In IEEE802.3 March 2014 meeting , Jeff Heat had a comment for the PD model. Jeff to send the details of it to the ad-hoc if you want us to discuss it. (Jeff to send data and Dave response to next meeting).
- No response. Removing this item from the agenda.

- 
- See new data for P2PCRUN with out limiting the current to 600mA /pair with 6 connectors (See Christian presentation)
  - See previous data presented again on Annex C on issues reminding us why we are working on P2P issues and what was the concerns that we had to addressed.

# Updated Worst Case Data Base

Adhoc: OK

Table 1	CAT5E Cable resistivity	CAT6/A Cable resistivity
Cable resistivity	117mOhm/m	66mOhm/m
Transformer winding resistance	120mOhm min, 130mOhm max	120mOhm min, 130mOhm max
2-connector <u>Contact resistance</u>	15mOhm min, 30mOhm max	15mOhm min, 30mOhm max
4-connector <u>Contact resistance</u>	30mOhm min, 60mOhm max	30mOhm min, 60mOhm max
6-connector <u>Contact resistance*</u>	45mOhm min, 90mOhm max	45mOhm min, 90mOhm max
Diode bridge	0.39V+0.25Ohm*Id min; 0.53V+0.25Ohm*id max	0.39V+0.25Ohm*Id min; 0.53V+0.25Ohm*id max
PSE output resistance (e.g. Rs_a/b=Rsense+Rdson)	0.25+0.1 Ohm min 0.25+0.2 Ohm max	0.1+0.05 Ohm min 0.1+0.1 Ohm max

- Source: Christian presentation on May, 8 2014 adhoc meeting.
- Diode model was changed
- **Replace connector contact resistor with Connector resistance. May 15, 2014**
- To supply Yair tests for connector tests
- To check what will be with 50miliom max difference. So it could be 10miliom minimum – 60miliohm max.
- Sterling to supply information for connector resistivity.
- To check CAT6A cable resistance per the actual cable length
- **Change titles of the two columns**

# CAT6/A, 2-connector model

Length [m]	PD power [W]	Pair with min current [mA]	Pair with max current [mA]	Idiff [mA]	P2PCRunb [%]
0.15	51	713.09	333.59	379.51	<b>36.26%</b>
1	51	703.75	343.54	360.21	<b>34.39%</b>
10	51	647.97	405.83	242.14	<b>22.98%</b>
100	51	612.77	516.87	95.89	<b>8.49%</b>
<hr/>					
0.15	75	975.35	571.98	403.37	<b>26.07%</b>
1	75	966.43	582.25	384.18	<b>24.81%</b>
10	75	915.09	648.09	267.00	<b>17.08%</b>
100	75	937.66	810.77	126.89	<b>7.26%</b>

- Source: Christian presentation on May, 8 2014 adhoc meeting.

# CAT6/A, 6-connector model

Length [m]	PD power [W]	Pair with min current [mA]	Pair with max current [mA]	Idiff [mA]	P2PCRunb [%]
0.15	51	711.42	337.09	374.33	<b>35.70%</b>
1	51	703.83	345.29	358.54	<b>34.17%</b>
10	51	654.98	400.77	254.21	<b>24.08%</b>
100	51	617.65	514.68	102.96	<b>9.09%</b>
<hr/>					
0.15	75	987.44	564.02	423.42	<b>27.29%</b>
1	75	979.68	573.15	406.53	<b>26.18%</b>
10	75	931.34	636.24	295.10	<b>18.83%</b>
100	75	947.13	808.59	138.54	<b>7.89%</b>

- Source: Christian presentation on May, 8 2014 adhoc meeting.

# CAT5E, 2-connector model

Length [m]	PD power [W]	Pair with min current [mA]	Pair with max current [mA]	Idiff [mA]	P2PCRunb [%]
0.15	51	713.08	336.22	376.86	<b>35.91%</b>
1	51	697.53	352.86	344.67	<b>32.81%</b>
10	51	628.90	433.31	195.58	<b>18.41%</b>
100	51	653.74	568.96	84.78	<b>6.93%</b>
<hr/>					
0.15	75	977.02	576.14	400.88	<b>25.81%</b>
1	75	962.23	593.34	368.89	<b>23.71%</b>
10	75	901.66	680.49	221.17	<b>13.98%</b>
100	75	1087.30	961.05	126.25	<b>6.16%</b>

- Source: Christian presentation on May, 8 2014 adhoc meeting.

# CAT5E, 6-connector model

Length [m]	PD power [W]	Pair with min current [mA]	Pair with max current [mA]	Idiff [mA]	P2PCR <sub>unb</sub> [%]
0.15	51	711.75	339.41	372.33	<b>35.42%</b>
1	51	698.99	353.28	345.72	<b>32.85%</b>
10	51	636.67	427.56	209.10	<b>19.65%</b>
100	51	658.14	568.37	89.77	<b>7.32%</b>
<hr/>					
0.15	75	989.47	567.90	421.57	<b>27.07%</b>
1	75	976.47	583.37	393.10	<b>25.20%</b>
10	75	917.08	669.74	247.35	<b>15.59%</b>
100	75	1099.57	964.24	135.33	<b>6.56%</b>

- Source: Christian presentation on May, 8 2014 adhoc meeting.

# Conclusions

---

- Worst case condition for P2P<sub>CR</sub>unb is:
  - Single 0.15m CAT6A cable between PSE and PD (2-connector model)
- The max P2P<sub>CR</sub>unb is 36.26%, i.e. 380mA over 1.05A
- Increasing the number of connector has a ballasting effect, decreasing P2P<sub>CR</sub>unb.
  - 4-connector results are in the middle between 2 and 4 connector models
- -----
- With CAT6/A cabling it is possible to deliver 75W to the PD without exceeding 1A per pair (for any cable length and # of connectors)
- A 100m CAT5E cable in a 6-connectors environment would require up to 1.1A to deliver 75W to the PD
- **Yair comment: This part is not final conclusions since it is worst case analysis. We need to check if with statistical analysis were lower P2P numbers are obtained, we can work with CAT5e as well and getting 75W at the load. There is benefit to use CAT5e as well for Type 4.**

# Comparison between 4 connectors and 6 connectors Model. -6

## Simulation Results

- Results for Table 1 right column data number set (minimum resistivity cable Type).
- Pairs were not limited to 0.6A
- Numbers were taken from the pairs with highest and lowest values.
- The model used is per Drawing #1

Simulation Results of worst-case analysis <b>with 4 connectors</b>				
Length[m]	Pair with minimum current [mA]	Pair with maximum current [mA]	Idiff=Max-Min [mA]	P2PCRunb [%]
0.15m				
1	385	659	275	26.30
10	415	636	221	21.04
100	500	626	126	11.19

Table 2

Simulation Results of worst-case analysis <b>with 6 connectors TBD</b>				
Length[m]	Pair with minimum current [mA]	Pair with maximum current [mA]	Idiff=Max-Min [mA]	P2PCRunb [%]
0.15m				
1				
10				
100				

Table 3



# Summary of open/closed issues -1

P=priority. P=1:Required for generating baseline draft numbers. P=2: May be part of informative section.  
P=3: Nice to know.

#	Subject	Reference/Conclusions	Status	P
1	Model for simulations/calculations	Figure 1	Ad-hoc OK.	1
2	Worst case data base	Table 1	Ad-hoc OK.	1
3	Cable Channel P2PRUNB 5% max	Meeting #1	Ad-hoc OK.	1
4	Worst case End to End Channel P2P resistance/current unbalance results with 4 connectors	Table 2	Ad-hoc OK.	1
5	What is the equation to calculate Resistance unbalance and Current unbalance?	Physic's, Meeting #1 and 2. Annex a, A1 $I_{unb} = R_{unb} * \text{Total load current.}$	Ad-hoc OK	1
6	sensitivity Analysis to identify the main contributors of lesser power delivery.	Table 4 and 5	Ad-hoc OK	3
7	Do we need to specify minimum length?	Meeting #2. See Wayne proposal for 4 channel length options	Ad-hoc OK	1
8	To define PSE PI P2PRUNB	Meeting #1 and 2	Ad-hoc OK	1
9	To define PD PI P2PRUNB	Meeting #1 and 2	Ad-hoc OK	1
10	To set equation for evaluation maximum current unbalance through transformers	$I_{bias} = I_{unbalance} / 2 = C_{P2PRU} * I_{cable\_max}$	Ad-hoc OK	2
11	To considering 100BaseT Ethernet devices or switches that do not implement transformers on the spare pairs so the range should be 0 Ohm to 130mOhm. •In the switch and PD, vendors will have to add equivalent resistor to compensate the PSE PI unbalance	Group response: This is implementation issue of PSE PD which needs to meet P2P channel resistance unbalance anyway.	Ad-hoc OK.	2

# Summary of open/closed issues -2

P=priority. P=1:Required for generating baseline draft numbers. P=2: May be part of informative section.  
P=3: Nice to know.

#	Subject	Reference/Conclusions	Status	P
12	How the constant power model at the PD helps us in regard to Channel P2PRUNB and specifically its effect on transformers?	Drawing 2. See the whole slide for details.	Ad-hoc OK.	1
13	sensitivity Analysis to identify the main contributors of resistance unbalance	Need to be done.	On going	1
14	Worst case End to End Channel P2P resistance/current unbalance results with 6 connectors	Table 3	On going	1
15	Statistical analysis results based on worst case data base in Table 1. Do we need to do it or we can live with worst case analysis?		On going	1
16	Channel P2PRUNB vs. operating temperature	Meeting #2 and #3. >room temperature: We don't care. Room temperature important for the standard. <Room temperature: Informative but not part of the standard	????	1
17	How connector contact aging will affect the results i.e. if min/max contact resistance difference will be increased	Meeting #1	???	1
18	Consider analyzing P2P current imbalance higher category cables than CAT6A.	Meeting #1 Response was: what will be the end of it? When to stop?	???	1

# Summary of open/closed issues -3

P=priority. P=1:Required for generating baseline draft numbers. P=2: May be part of informative section. P=3: Nice to know.

#	Subject	Reference/Conclusions	Status	P
19	What is the load current that below it we don't care about Channel, PD PI and PSE PI P2PRUNB	Meeting #2 and 3	???	1
20	What is the minimum resistance in the channel that above it, we don't care about END TO END CHANNEL P2PRUNB?	Meeting #2		2
21	What is the wire resistance per meter for patch cords?	Meeting #2 and 3. Proposed 0.14Ω/m	????	1
22	To generate worst case analysis curve of maximum pair current vs cable length for Type 3 PD (51W max.)	Drawing 2. See the whole slide for details.	On going.	1
23	To investigate worst case results the 4 options proposed by Wayne	Summary of 2 <sup>nd</sup> meeting.	On going.	2



- Previous Meeting Material

# Meeting # 1 Attendees (Monday Feb 17,2014)

- Yan Zhuang / Huawei
- Abramson David / TI
- Kousalya Balasubramanian/ Cisco
- Leonard Stencil / Bourns
- Larsen Wayne / Commscope
- Woudenberg Rob / Philips
- Picard Jean / TI
- Steinke Stephan / Molex
- George Zimmerman / CME Consulting / Commscope
- Sessa Panguluri/Broadcom
- Ken Bennett/ Sifos

- Gaoling Zou / Maxim
- Dave Dwelley / LT
- Lennart Yseboodt / Philips
- Wendt, Matthias / Philips
- Christian Beia / ST
- David Law / Hp

# Meeting # 2 Attendees (Monday Feb 24,2014)

- Yan Zhuang / Huawei
- Kousalya Balasubramanian/ Cisco
- Leonard Stencil / Bourns
- Larsen Wayne / Commscope
- Ken Bennett/ Sifos
- Dave Dwelley / LT
- Jeff Heath / LT
- Christian Beia / ST
- Steinke Stephan / Molex
- George Zimmerman / CME
- Victor Renteria/BEL
- Abramson David / TI
- Gaoling Zou / Maxim
- Tremblay David/ HP
- Lennart Yseboodt / Philips
- Rob Woudenberg / Philips

# Summary of previous work and conclusions -1

## Cable pair to pair resistance unbalance (P2PRU)



- In order to specify the ***pair to pair channel resistance imbalance*** we had to know the channel ***components pair to pair*** resistance unbalance such as:
  - Cable (not defined by cabling vendors),
  - Connectors, (Specified but not represents worst case numbers)
  - Transformers, (Vendors data is available. Not part of the formal channel)
  - PSE output resistance (Vendors data is available. Not part of the formal channel)
  - PD input resistance (Vendor data is available, Not part of the formal channel)
- We have good and sufficient data for all the components **except the cable**.
- We developed a method that predicted the cable Pair to Pair resistance imbalance from the other cable parameters such Propagation delay, Skew, wire diameter, wire insulation material and other.
- The predictions showed that P2P Cable Resistance Unbalance <5%
- Lab Tests confirmed that it was <5%
- Long list of experts (including cable experts) agree with the conclusions.
- All details can be found in:  
[http://www.ieee802.org/3/4PPOE/public/nov13/darshan\\_01\\_1113.pdf](http://www.ieee802.org/3/4PPOE/public/nov13/darshan_01_1113.pdf)

# Summary of previous work and conclusions -2

## Channel pair to pair resistance unbalance (C\_P2PRU)

---

- Initial Work to determine channel pair to pair resistance unbalance:
  - [http://grouper.ieee.org/groups/802/3/4PPOE/public/jul13/beia\\_1\\_0713.pdf](http://grouper.ieee.org/groups/802/3/4PPOE/public/jul13/beia_1_0713.pdf)
  - [http://grouper.ieee.org/groups/802/3/4PPOE/public/jul13/darshan\\_2\\_0713.pdf](http://grouper.ieee.org/groups/802/3/4PPOE/public/jul13/darshan_2_0713.pdf)
- After getting comments from the group and using same worst-case data base and model:
  - [http://www.ieee802.org/3/4PPOE/public/nov13/darshan\\_03\\_1113.pdf](http://www.ieee802.org/3/4PPOE/public/nov13/darshan_03_1113.pdf)
  - [http://www.ieee802.org/3/4PPOE/public/nov13/beia\\_01\\_1113.pdf](http://www.ieee802.org/3/4PPOE/public/nov13/beia_01_1113.pdf)
- General Channel Model and its components that we have used: See next slide.



# Summary of previous work and conclusions

-3

General Channel Model and its components that we have used.

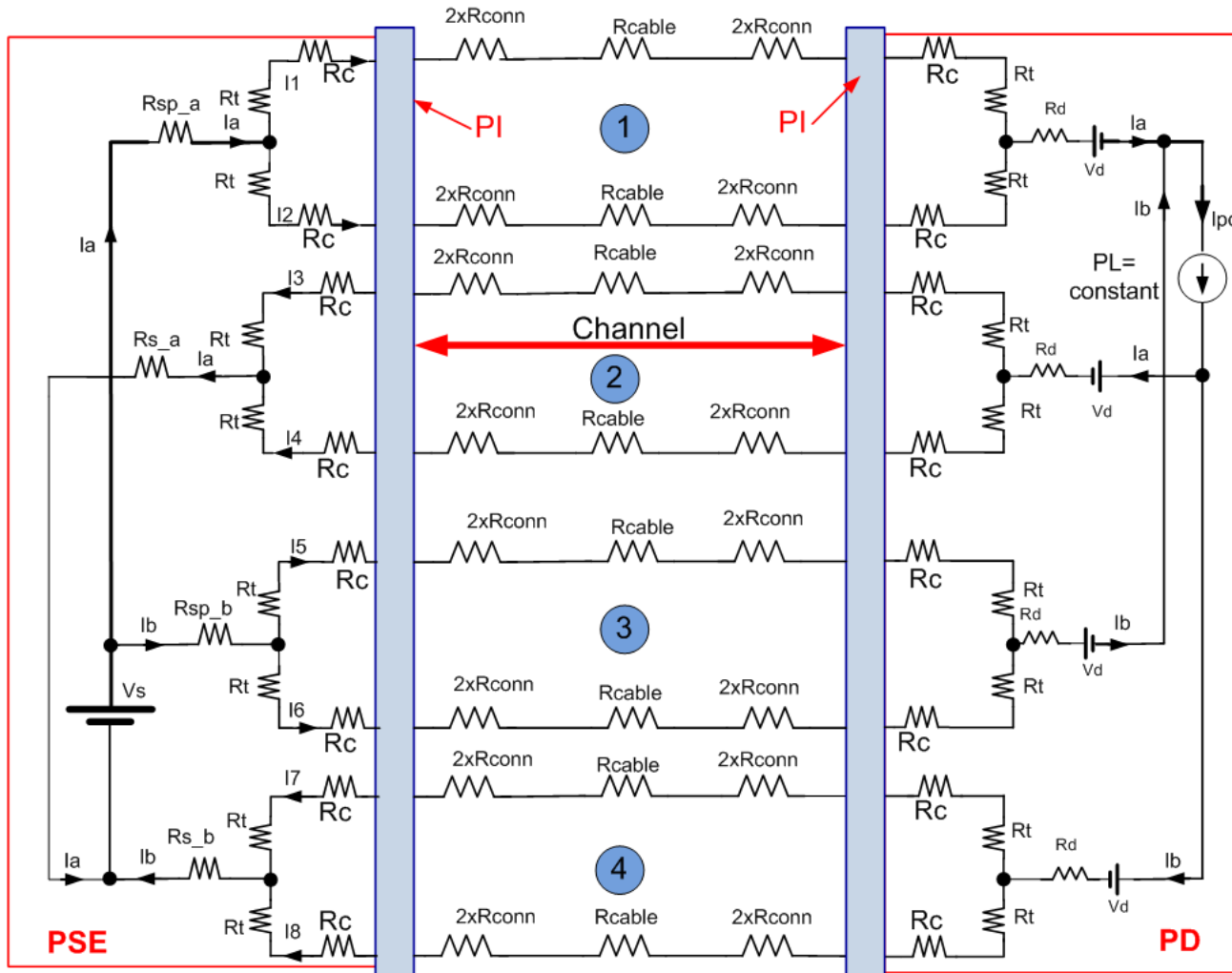

Drawing 1

## Notes for the general Model:

1. Adding resistors on positive path for general model ( $R_{sp\_a}$  and  $R_{sp\_b}$ ). It can be set to zero or  $>zero$  pending the case being investigated.
2. Adding equipment connectors per Wayne's comment. So total end to end channel connectors is 6 max.
3. The formal channel definition is marked in red arrow.
4. Our work addresses also the internal application resistance of known components that are used

# Summary of previous work and conclusions

-4

Data set that we use as worst case numbers

From: [http://www.ieee802.org/3/4PPOE/public/nov13/beia\\_01\\_1113.pdf](http://www.ieee802.org/3/4PPOE/public/nov13/beia_01_1113.pdf)

<b>Table 1</b>	<b>Data set 1 (Max Cable resistivity)</b>	<b>Data set 2 (Min Cable resistivity)</b>
Cable resistivity	117mOhm/m* (maximum value) (CAT5e) Pair resistance unbalance: 2% → Minimum wire resistance=0.98*117mΩ/m Pair to pair resistance unbalance: 5% → Pair resistance max=~(117mΩ/m)/2 → Pair resistance min=~(0.95*117mΩ/m)2	66mOhm/m* (CAT6A) Pair resistance unbalance: 2% → Minimum wire resistance=0.98*66mΩ/m Pair to pair resistance unbalance: 5% → Pair resistance max=~(66mΩ/m)/2 → Pair resistance min=~(0.95*66mΩ/m)2
Transformer winding resistance	120mOhm min, 130mOhm max	120mOhm min, 130mOhm max
Contact resistance	30mOhm min, ** 60mOhm max	30mOhm min, ** 60mOhm max
Diode bridge	0.39V+0.25Ohm*Id min; 0.53V+0.25Ohm*id max	0.39V+0.25Ohm*Id min; 0.53V+0.25Ohm*id max
PSE output resistance (e.g. Rs_a/b= Rsense+Rdson)	0.25+0.1 Ohm min 0.25+0.2 Ohm max	0.1+0.05 Ohm min 0.1+0.1 Ohm max

- Two scenarios have been identified: max wire resistivity Data set 1 (CAT5E cables) and min wire resistivity Data set 2 (CAT6/A cables)
- \*Cable pair to pair resistance max unbalance is set to 5%. See darshan\_1\_1113.pdf. Cable resistance within pair unbalance is max 2%.
- \*\*Connector contact aging will be addressed in other work.
- All parameters are at room temperature and further study is required to address temperature variations

# Summary of previous work and conclusions

-5

## Simulation Results

- Results for Table 1 right column data number set (minimum resistivity cable Type).
- Pairs were not limited to 0.6A
- Numbers were taken from the pairs with highest and lowest values.
- The model that was simulated is with 4 connectors only as in the link below.
  - [http://www.ieee802.org/3/4PPOE/public/nov13/darshan\\_03\\_1113.pdf](http://www.ieee802.org/3/4PPOE/public/nov13/darshan_03_1113.pdf)

Simulation Results of worst-case analysis				
Length[m]	Pair with minimum current [mA]	Pair with maximum current [mA]	Idiff=Max-Min [mA]	P2PCRUnb [%]
1	385	659	275	26.30
10	415	636	221	21.04
100	500	626	126	11.19

Table 2

$$P2PCRUNB = \frac{I_{max} - I_{min}}{I_{max} + I_{min}}$$

# Summary of previous work and conclusions -6

- See details:  
[http://www.ieee802.org/3/4PPOE/public/nov13/beia\\_01\\_1113.pdf](http://www.ieee802.org/3/4PPOE/public/nov13/beia_01_1113.pdf)
- What we did was a We need to do the work for sensitivity analysis for channel pair to pair resistance unbalance regardless of power delivery constrains.

Max res scenario	Component UNB[±]	Effect on power delivery [-]		
		1m	10m	100m
Cable lenght				
Rt	4%	0.17%	0.10%	0.01%
Rconn	33.30%	1.02%	0.58%	0.08%
r_cable	5%	0.20%	1.13%	<b>1.68%</b>
Rdiode	11.10%	3.43%	1.96%	0.32%
Vdiode	14.30%	<b>5.72%</b>	<b>3.27%</b>	0.53%

Table 4

Min res scenario	Component UNB[±]	Effect on power delivery [-]		
		1m	10m	100m
Cable lenght				
Rt	4%	0.18%	0.12%	0.03%
Rconn	33.30%	1.06%	0.73%	0.16%
r_cable	5%	0.12%	0.81%	<b>1.79%</b>
Rdiode	11.10%	3.56%	2.48%	0.57%
Vdiode	14.30%	<b>5.94%</b>	<b>4.14%</b>	0.96%

Table 5

# Summary of previous work and conclusions

-7

## Conclusions

---

- See details:  
[http://www.ieee802.org/3/4PPOE/public/nov13/beia\\_01\\_1113.pdf](http://www.ieee802.org/3/4PPOE/public/nov13/beia_01_1113.pdf)
- Main conclusions relevant for channel pair to pair resistance unbalance (short summary)
- P2P current imbalance increases when cable length decreases.
- P2P current imbalance increases when cable resistivity decreases i.e. CAT6A will have higher current imbalance compared to CAT5e.
- Unbalance within a pair (the famous 2% pair and 3% channel) has negligible effect on P2P unbalance.
- We need to define the requirements for P2P Runb for the PD, Channel and PSE in order to meet our objectives.

# Summary of previous work and conclusions

-8

## Conclusions

---

- To analyzed the following scenarios:
  - How connector contact aging will affect the results i.e. if min/max contact resistance difference will be increased.
  - The current unbalance results as function of operating temperature range
  - To analyze the results when there is no hard limit of 600mA on the negative pair. **Done:** See Table 2 and see: [http://www.ieee802.org/3/4PPOE/public/nov13/darshan\\_03\\_1113.pdf](http://www.ieee802.org/3/4PPOE/public/nov13/darshan_03_1113.pdf)
  - Consider analyzing P2P current imbalance higher category cables than CAT6A
    - **Response at the meeting was: what will be the end of it? When to stop?**
  - To perform sensitivity analysis for P2P resistance (current) imbalance.
  - To set a worst case conditions for evaluating maximum current imbalance through transformers.

**Done:**  $I_{bias} = I_{unbalance} / 2 = CP2PRU * I_{cable\_max}$ .

# What are the parameters that must be define?

- As done in IEEE802.3-2012 (*See Annex A*) when we define the pair (wire to wire in the same pair) in the cable pair(s) and in the channel, we need to do it for the Pair to Pair Resistance Unbalance in the cable and in the channel.
- Cable Pair to Pair Resistance Unbalance (P2PRU)
  - Based on the work done at [http://www.ieee802.org/3/4PPOE/public/nov13/darshan\\_01\\_1113.pdf](http://www.ieee802.org/3/4PPOE/public/nov13/darshan_01_1113.pdf) , it is proposed to specify it to 5% until formal number will be received from TIA/EIA. (group OK with recommendation)
- Channel Pair to Pair Resistance Unbalance (C\_P2PRU)
  - We need to decide if we can work with the worst case numbers? Or we need to add the probability factors to lower them.
    - To add probability factors and move on (request from magnetic vendors for lowest number).

# Analysis Methods and Data-Base

---

- Analysis Method
  - Worst-Case Analysis
    - We did a worst-case analysis for the channel pair to pair resistance unbalance on a proposed worst-case data
    - Any comments on the worst-case data base?
      - To considering 100BaseT Ethernet devices or switches that do not implement transformers on the spare pairs so the range should be 0 Ohm to 130mOhm.
        - In the switch and PD vendor will have to add equivalent resistor to compensate the PSE PI unbalance. To discuss this approach.
        - Group response: This is implementation issue of PSE PD which needs to meet P2P channel resistance unbalance anyway.
      - Any comments on the model used (Group response: No.)
- Next Steps



## Do we need to specify PSE and PD PI P2P Resistance Unbalance or leave it to be implementation specific as long as C\_P2PRU is met?

- Do we need to specify the following additional parameters or leave it to be implementation specific as long as C\_P2PRU is met?
  - PSE PI Pair to Pair Resistance Unbalance (PSE\_P2PRU)
  - PD PI Pair to Pair Resistance Unbalance (PSE\_P2PRU)
  - In the current standard the pair resistance unbalance was defined to 2% and the channel (cable and connector only) to 3% (See Annex A).
  - It was the responsibility of the equipment vendor to make sure that his design will meet all system requirement based on the above specification.
  - In 802.3at extensive work was done and shows that the actual pair channel resistance unbalance is higher than 3% (due to other components in the system) and yet system vendors and components ensure operation under this conditions.
  - Now we are addressing the P2P channel Resistance Unbalance and we have the same question: Do we need to specify the following additional parameters or leave it to be implementation specific as long as C\_P2PRU is met?
    - If we do want to define PSE\_P2PRU and PD\_P2PRU.
    - Should we define only PD\_P2PRU since it is not always required for the PD (it is PD power dependent and if defined at PSE it will be required for every port

# Discussions and conclusions

- To ask magnetic component vendors if they can handle the worst-case analysis numbers or we should do statistical analysis as well.
  - If they can, we use the results to define the end to end channel P2P resistance unbalance.
- To define 3 new parameters
  - (1) To define the channel (PI to PI) Resistance unbalance (cables and connectors) with the contributions of PSE and PD PI P2P Resistance Unbalance.
- From (1) to separately define
  - PSE PI P2PRUNB and PD P2PRUNB
  - To define the channel (PI to PI) Resistance unbalance (cables and connectors).
  - As a result component and system vendors could use it for designing their components.
- We accept that P2P Cable Resistance Unbalance is 5% until formal number will be received by TIA/EIA etc.
- Yair to work with transformer vendors to get the data we need.
- To look for the best cable (lower resistance per meter) expected in the next 10+years and use it in our worst case data base numbers.
- To verify that LDO is covered by PD constant power sink. Done. It is covered.
- To consider 100BaseT Ethernet devices or switches that do not implement transformers on the spare pairs so the range should be 0 Ohm to 130mOhm.
  - In the switch and PD vendor will have to add equivalent resistor to compensate the PSE PI unbalance. To discuss this approach.
- No other comments on previous work done nor on model or database used.
- Group to send comments on model and data base and we will update it if found.

# For next meeting

-1

- To discuss the advantages that PD constant Power Sink allows us.
- Background material for considering:
  - Worst case End to End Channel Pair to Pair Channel Resistance Unbalance is at short cable (<100m).
  - At short cables PD voltage is higher that at 100m channel length and pair/port current is lower
  - Not only that the port current is lower, it is <600mA for Type 3 systems below TBD channel length.
  - As a result, P2PCRUNB is not an issue.
  - At 100m the P2PCRUNB is much smaller than at short channel
  - Resulting with less significant contribution to I<sub>bias</sub> due to P2PCRUNB and as a result to OCL.
  - **This approach was validated in:**  
[http://grouper.ieee.org/groups/802/3/4PPOE/public/jul13/darshan\\_2\\_0713.pdf](http://grouper.ieee.org/groups/802/3/4PPOE/public/jul13/darshan_2_0713.pdf) and requires further investigation for completing this work.

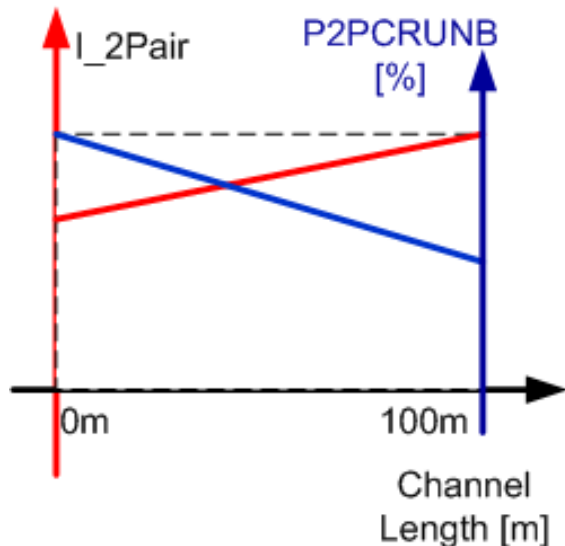

**Source:**

1. See link above, from July 2013.
2. Adhoc meeting #2, February 24, 2014.

Illustration of the behavior.  
(The curve is not linear. It is just describing the trend.)

Drawing 2

# For next meeting

-2

- We need to define the PD load current on Mode A and Mode B in which below that current, P2P requirements can be ignored.
  - Example: if Mode A requires 350mA and Mode B require 113mA than P2P discussion is not relevant to this case.

# PSE\_Pi Pair to Pair Resistance Unbalance

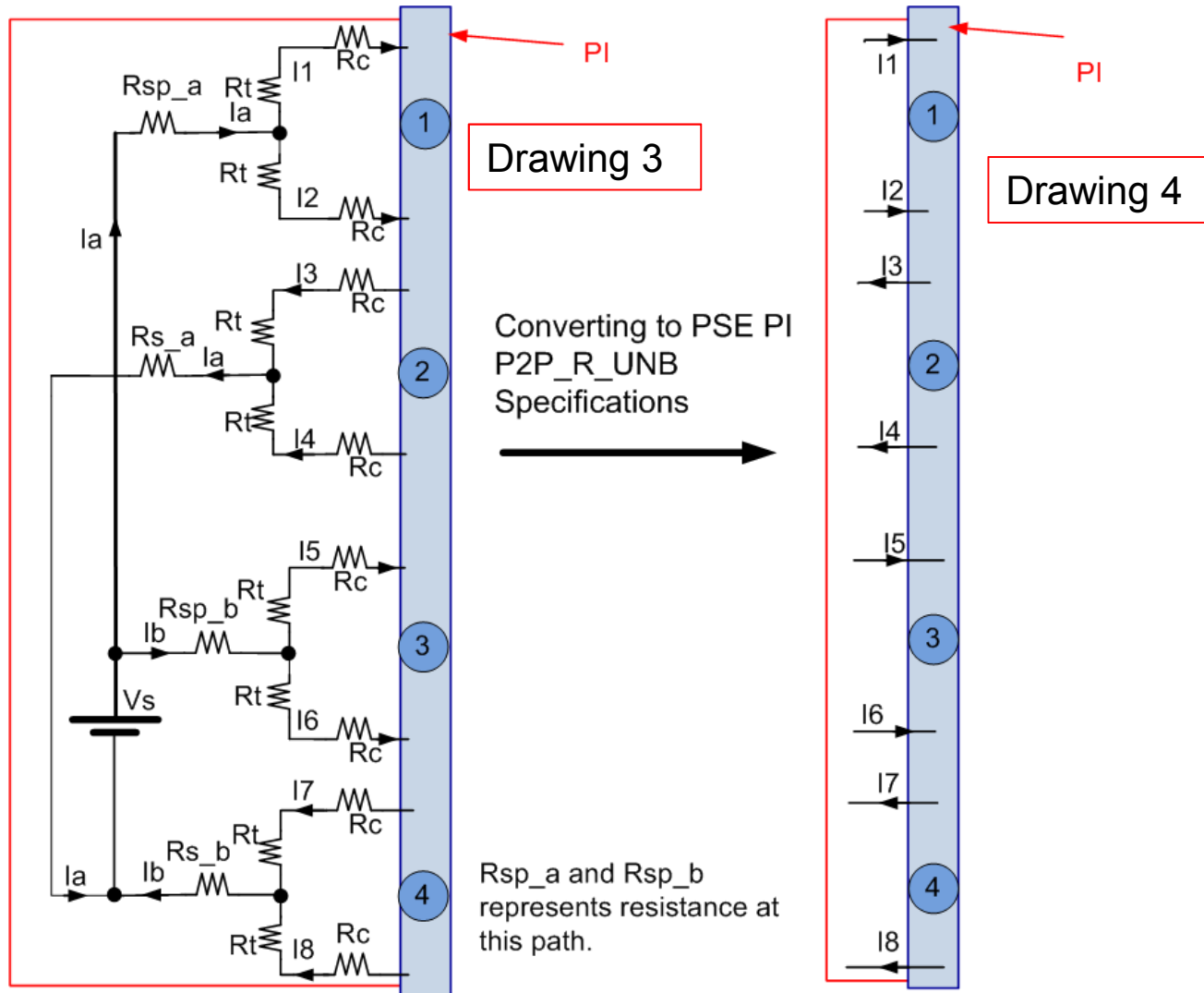

- To specify test setup as well

# PD\_P1 Pair to Pair Resistance Unbalance

- Same concept for PD P1 P2P\_R\_UNB definitions
- To specify test setup
- We may need to define P2P voltage offset difference in addition to P2P resistance unbalance

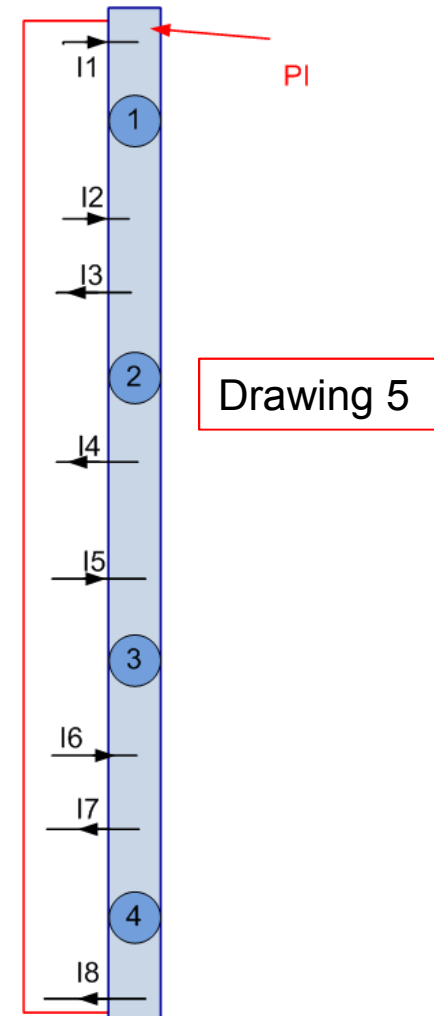

# Summary of 2<sup>nd</sup> meeting

- 1

- (Text marked blue was added after the meeting and is not part of the meeting summary. It will be discussed on our 3<sup>rd</sup> meeting to be approved.)
- Wayne Larsen present data regarding:
  - Summary of resistivity and resistance unbalance specifications in TIA cabling standards
  - **Suggested topologies to study**
    - A. 6 inch (0.15 m) of cordage, no connectors.
    - B. 4 m channel with 1 m of cordage, 3 m of cable, 2 connectors
    - C. 23 m channel with 8 m of cordage, 15 m cable, 4 connectors
    - D. 100 m channel with 10 m of cordage, 90 m of cable, 4 connectors
  - Calculated channel resistance and unbalance (not including PSE and PD components) for the above topologies and the calculation details in separate Excel file done for maximum TIA numbers.
- Yair notes for the calculation results
  - The results reflects maximum cable (9.38Ω/100m) and connectors (300mΩ) resistance specified by TIA. *We are looking for lower cable resistance and connectors to reflect real life and also worst case in terms of P2PCRUB.*
  - *Christian and Yair proposed to use cable with 66mOhm/m and connectors with 30mOhm min, 60mOhm max per the data in slide 9.*
  - Proposed channel length options to investigate looks reasonable.

# Summary of 2<sup>nd</sup> meeting

- 2

- We review the updated model and we agree to use it as our base line for simulating different operation scenarios.
- Until other worst case numbers regarding cables and other components in the channel from end to end, we will use the numbers in the table slide 9, minimum resistivity cable model column.
- We adopt the 5% cable P2PRUNB until formal number will be received from TIA/EIA etc.
- We add two additional connectors to the model to investigate the effect of it on the end to end P2PCRUNB.

(formal channel is 4 connectors maximum)

- To consider 100BaseT Ethernet devices or switches that do not implement transformers on the spare pairs so the range should be 0 Ohm to 130mOhm.
  - Yair note: In the Switch/Midspan and PD vendors will have to add equivalent resistor to compensate the PSE PI unbalance.
  - Group: This is implementation issue of PSE PD which needs to meet P2P channel resistance unbalance anyway. We will craft the optimum wording when the time comes.



- The following questions and issues were raised
- (1) What is the minimum resistance in the channel that above it, we don't care? In other words, what is the minimum resistance in the PD that makes the diodes, connectors, transformers less important in the total channel P2PRUNB?
- (2) Do we need to specify minimum length?
  - Yair: we will know the answer based on (1) and running simulations/calculations per Wayne proposal for 4 channel length options.
- What will be minimum  $\Omega/m$  for patch cords?
  - Yair: I suggest to use the  $9.38\Omega/100m$  ( $93.8m\Omega/m$  as max value and 5% less as the minimum value since patch cords normally need to be flexible than the horizontal cable so their wire diameter is smaller than horizontal cables such as CAT6A.
  - Yair: I remember that Wayne said that the 0.15m channel length option is with  $14 \Omega/100m$ .
    - Wayne to confirm.
    - Wayne: What is your opinion to the above proposal?

# Summary of 2<sup>nd</sup> meeting

- 4

- We need to define the PD load current on Mode A and Mode B in which below that current, P2P requirements can be ignored.
  - Example: if Mode A requires 350mA and Mode B require 113mA than P2P discussion is not relevant to this case.
- We agree that we need to investigate it and address it.
- **Dave Dwelley made a comment about this issue which I didn't record.**
- **Dave please send us your comment about this topic to be recorded and addressed.**
  
- We need to conduct sensitivity analysis for P2PCRUNB with constant power sink and without limitations on current per pair. What we had is for determining the PD minimum available power.

- How to address temperature effect on P2PCRUNB?
  - We agree that we don't care of high temperature since it works for us (high temperature higher resistance lower P2PCRUNB)
  - So the question is narrowed to below room temperature (20-24°C)?.

Yair:

1. All parameters in the standard are tested for compliance at room temperature. (to confirm)
2. System and component vendors are responsible to design the parts/system to meet their spec over their spec operating temperature range.
3. We can study and supply the guidelines/equations in informative annex to help decide what to do in temperatures below room temperature but it can't be part of the standard.
4. Please see what IEEE802.3-2012 says about this topic:

### **33.7.7 Temperature and humidity**

The PD and PSE powered cabling link segment is expected to operate over a reasonable range of environmental conditions related to temperature, humidity, and physical handling. Specific requirements and values for these parameters are beyond the scope of this standard.

# Proposal for PSE PI P2PRUNB model

## Step 1: Converting 8 wires model to 4P Common Mode Model

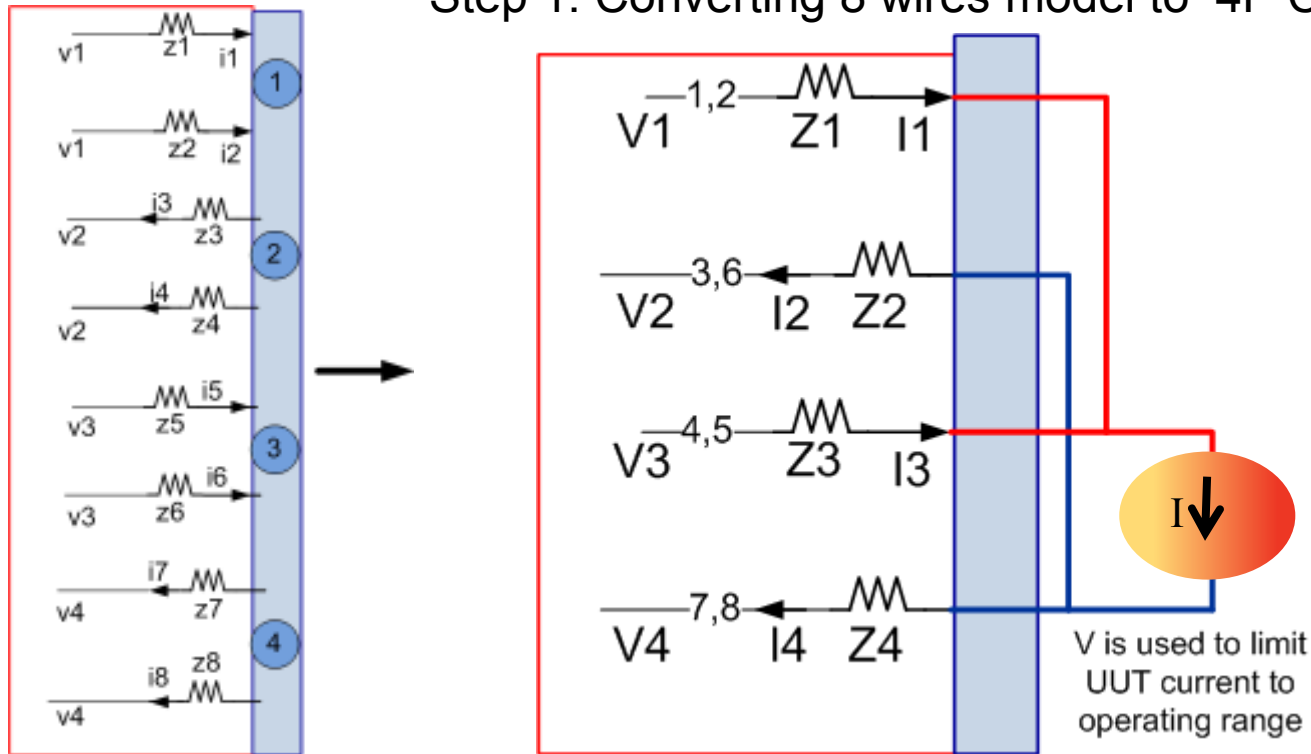

- Model is implementation independent
- $Z_i$  is the CM impedance of the implementation per pair.  $i=1$  to 4.
  - **We are interested in the DC value of that Impedance.**
- $V_i$  is the voltage measured to the common point.
- $I_i$  is PSE I<sub>cable</sub> current operating range per PSE type at ON\_STATE.
- We want to specify P2P PSE PI Resistance Unbalance in terms of  $V_i$  and  $I_i$ .

# Requirement Derivation - 1

- By definition:
- $I_1 = (V_1 - V) / Z_1 \rightarrow Z_1 = (V_1 - V) / I_1$
- $I_2 = (V_2 - V) / Z_2 \rightarrow Z_2 = (V_2 - V) / I_2$
- $I_3 = (V_3 - V) / Z_3 \rightarrow Z_3 = (V_3 - V) / I_3$
- $I_4 = (V_4 - V) / Z_4 \rightarrow Z_4 = (V_4 - V) / I_4$

- By definition:
- P2P PSE PI Zunbalance=

$$= \frac{Z_i - Z_j}{Z_i + Z_j} = \frac{\frac{V_i}{I_i} - \frac{V_j}{I_j}}{\frac{V_i}{I_i} + \frac{V_j}{I_j}} = TBD \text{ max}$$

Between any two pairs  $i \neq j$ .

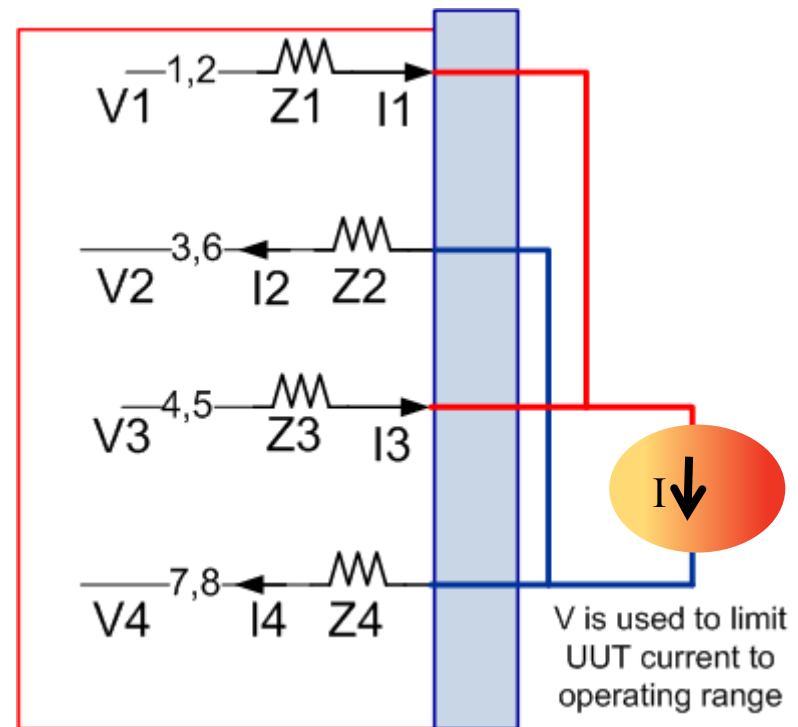

# Requirement Derivation - 2

- P2P PSE PI Zunbalance=

$$= \frac{Z_i - Z_j}{Z_i + Z_j} = \frac{\frac{V_i - V}{I_i} - \frac{V_j - V}{I_j}}{\frac{V_i - V}{I_i} + \frac{V_j - V}{I_j}} = TBD \text{ max}$$

Between any two pairs  $i \neq j$ .

Since we need Z in DC  $\rightarrow Z \rightarrow R$

$$(1) \frac{Z_i - Z_j}{Z_i + Z_j} = \frac{R_i - R_j}{R_i + R_j} = P2PRUNB \text{ max,}$$

$$(2) |v_1 - v_3| < TBD$$

$$(3) |v_2 - v_4| < TBD$$

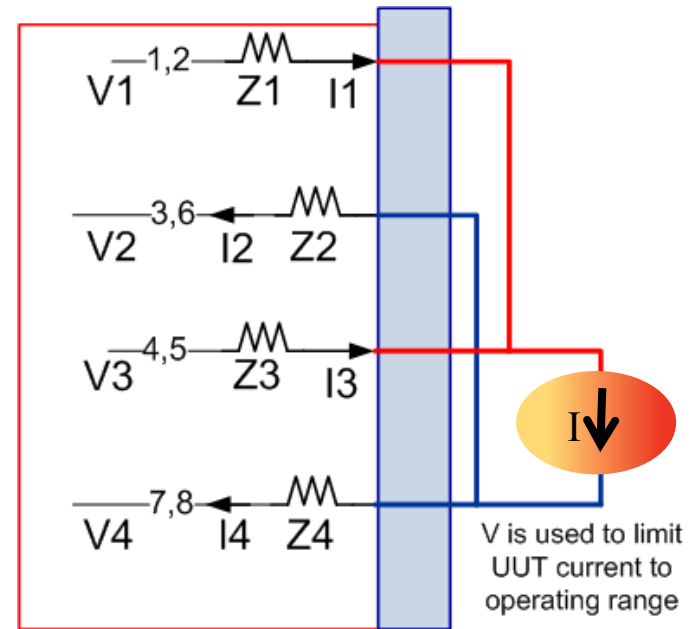

Ri is function of Vi/Ii which addresses non linear circuitry at worst case unbalance operating point defined by PSE vendor.

# Comments?

---