

Section 33.7 Loss of management frame communication

Both PSE and PD can detect a loss of communication based on monitoring LLDPDU on the link. In addition the PSE can take into account an indication from the PD that a loss of communication has occurred.

Section 33.7.1 PSE loss of communication

The condition that needs to be considered in this context is the expiration of the LLDP time to live (TTL) timer associated with the remote system (see IEEE Std 802.1AB-200X, subclause 9.5.4). When this condition happens, the PSE remains operational using the last acknowledged classification state.

If this condition persists for time duration that is greater of 3 x 30 seconds and 3 x TTL timeout value for the remote system a PSE shall assert the state variable `pse_loss_comms_detection`.

A PSE may remove power if either of the state variables `pse_loss_comms_detection` or `pd_loss_comms_indication` is asserted.

Section 33.7.2 PD loss of communication

The condition that needs to be considered in this context is the expiration of the LLDP time to live (TTL) timer associated with the remote system (see IEEE Std 802.1AB-200X, subclause 9.5.4). When this condition happens, the PD remains operational using the last acknowledged classification state.

If this condition persists for time duration that is greater of 3 x 30 seconds and 3 x TTL timeout value for the remote system, a PD shall assert the state variable `pd_loss_comms_detection`.

Insert the following paragraph: line 22 page 104

If a PSE does not receive an LLDPDU containing a DTE Power via MDI classification TLV from a Type-2 PD within 5 minutes of transmitting the first LLDPDU, the PSE may revert to Class 0 power level.

Section 30.9.2.1.11

`aLostCommunication` and `aMirroredLostCommunication` are defined as counters. This should actually be boolean.

Make the following change:

`aLostCommunication`

ATTRIBUTE

APPROPRIATE SYNTAX:

A BOOLEAN value:

FALSE Local system is receiving LLDP DLL Classification frames from remote system

TRUE Local system is not receiving LLDP DLL Classification frames from remote system

BEHAVIOUR DEFINED AS:

A GET operation returns the communication status of the local system.

aMirroredLostCommunication

ATTRIBUTE

APPROPRIATE SYNTAX:

A BOOLEAN value:

FALSE Remote system is receiving LLDP DLL Classification frames from local system

TRUE Remote system is not receiving LLDP DLL Classification frames from local system

BEHAVIOUR DEFINED AS:

A GET operation returns the communication status of the remote system.

Section 30.9.1.1.21

aLostCommunication and aMirroredLostCommunication are defined as counters. This should actually be boolean.

aLostCommunication

ATTRIBUTE

APPROPRIATE SYNTAX:

A BOOLEAN value:

FALSE Local system is receiving LLDP DLL Classification frames from remote system

TRUE Local system is not receiving LLDP DLL Classification frames from remote system

BEHAVIOUR DEFINED AS:

A GET operation returns the communication status of the local system.

aMirroredLostCommunication

ATTRIBUTE

APPROPRIATE SYNTAX:

A BOOLEAN value:

FALSE Remote system is receiving LLDP DLL Classification frames from local system

TRUE Remote system is not receiving LLDP DLL Classification frames from local system

BEHAVIOUR DEFINED AS:

A GET operation returns the communication status of the remote system.

Add the following variables to section 33.6.6.2

pse_loss_comms_detection

This variable is mapped into the aLostCommunication attribute (30.9.1.1.21).

Values: TRUE: Loss of communication as defined in 33.7.1 has occurred in the PSE local system
FALSE: Loss of communication as defined in 33.7.1 has not occurred in the PSE local system

pd_loss_comms_indication

This variable is mapped from the aMirroredLostCommunication attribute (30.9.1.1.22).

Values: TRUE: Loss of communication as defined in 33.7.2 has occurred in the remote system and mirrored at the PSE
FALSE: Loss of communication as defined in 33.7.1 has not occurred in the remote system and mirrored at the PSE

pd_loss_comms_detection

This variable is mapped into the aLostCommunication attribute (30.9.2.1.11).

Values: TRUE: Loss of communication as defined in 33.7.2 has occurred in the PD local system
FALSE: Loss of communication as defined in 33.7.2 has not occurred in the PD local system

Remove the variable loss_of_comms

PSE State Diagram

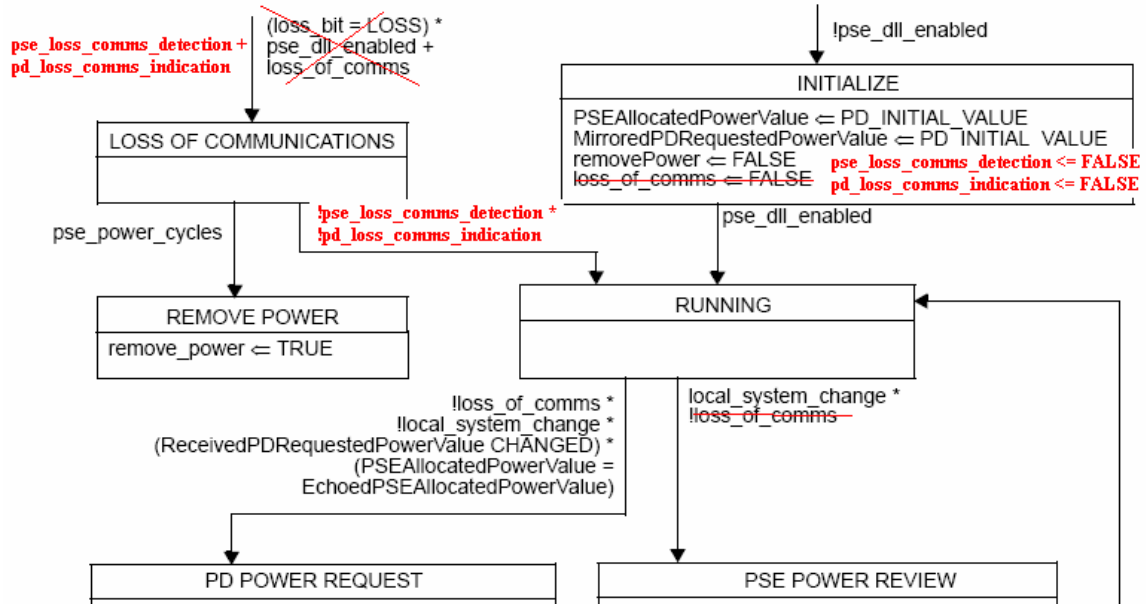

PD State Diagram

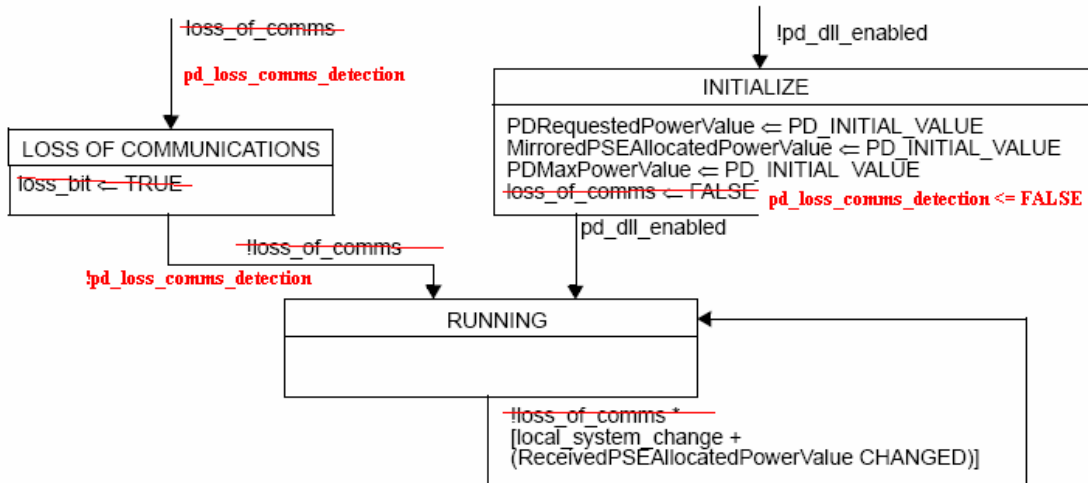

Object	Attribute	Mapping	State diagram variable
oPSE managed object class	aDLLPSEAllocatedPowerValue	<=	PSEAllocatedPowerValue
	aEchoedDLLPSEAllocatedPowerValue	=>	EchoedPSEAllocatedPowerValue
	aReceivedDLLPDRequestedPowerValue	=>	ReceivedPDRequestedPowerValue
	aMirroredDLLPDRequestedPowerValue	<=	MirroredPDRequestedPowerValue
	aLostCommunication	<=	pse_loss_comms_detection
	aMirroredLostCommunication	=>	pd_loss_comms_indication
oPD managed object class	aDLLPDRequestedPowerValue	<=	PDRequestedPowerValue
	aReceivedDLLPSEAllocatedPowerValue	=>	ReceivedPSEAllocatedPowerValue
	aMirroredDLLPSEAllocatedPowerValue	<=	MirroredPSEAllocatedPowerValue
	aLostCommunication	<=	pd_loss_comms_detection