



NG-EPON Fragmentation

Open Discussion

- Don't forget our CFI:
 - We Steal
 - We Fight

What is needed to fragment?

- Definition of min fragment size
 - FEC CW has been suggested
 - This might change depending on final FEC decision.
- Control signal from MPCP+ to control:
 - Burst start
 - Frame start
 - Fragment end
 - Fragment start
 - Frame end
 - Burst end
- Indication to receiver of each of the above

Min fragment size

- Things to consider during FEC selection if it is also related to fragmentation
 - How small (granular) is the FEC data size?
 - How well does the FEC data size match the shortened 64B/66B line code size?

Steal from Preemption

- Ctrl Signal:
MM_CTL.request
 - Two values
 - Hold
 - Release

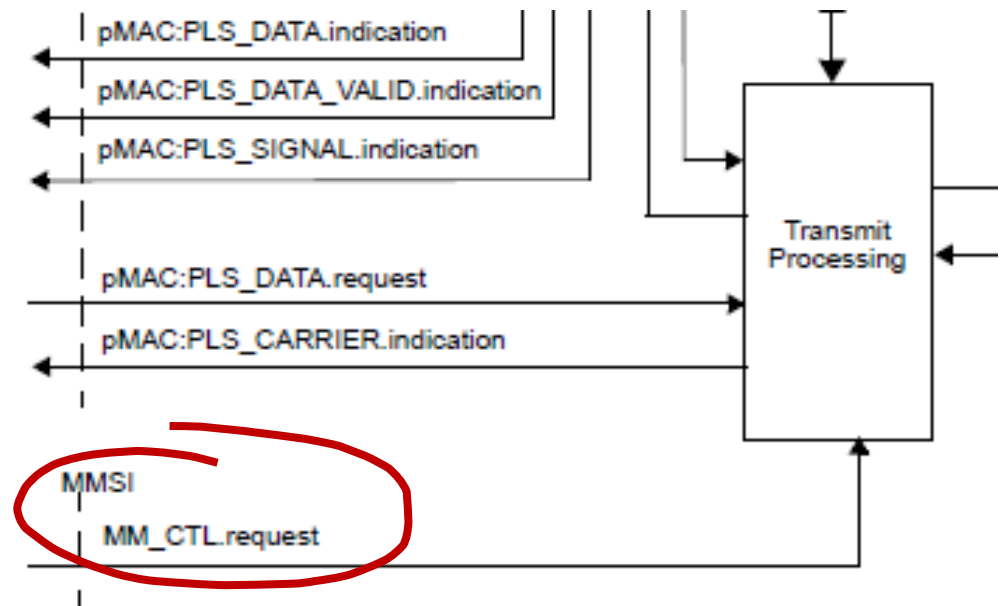

Excerpt from Fig 99-3

Control

- Invent new signal to control fragmentation similar to MM_CTRL.request
- EF_CTRL.request (EPON Fragment)
 - Determines transmit enable/disable
 - Determines Lane use 1, 2, 3, 4
 - Ex. 4b bit mapped signal
 - 0b0000 = tx disable - if transmitting;
fragment & stop transmission
 - 0bxxx1 = tx enable lane 1
 - 0bxx1x = tx enable lane 2
 - 0bx1xx = tx enable lane 3
 - 0b1xxx = tx enable lane 4

} if DATA.request = 0/1;
transmit data

What else can we Steal?

- Current Preamble defines
 - Burst start
 - Frame start
 - Can we modify it to also indicate Fragment start?
 - Preemption fragments a frame
 - Replaces SFD to indicate:
 - New frame, fragment end, fragment start
 - Preemption defines mCRC (see 99.3.6)
 - Marks end of a fragment
 - FCS XORed with 0x0000FFFF
 - Frame Check Sequence defines Frame End
- Burst start
 - Frame start
 - Fragment end
 - Fragment start
 - Frame end
 - Burst end

Steal from Preemption

- SMD
(replaces SFD)
 - Frame start
 - Fragment start

- Burst start
- Frame start
- Fragment end
- Fragment start
- Frame end
- Burst end

Table 99-1—SMD values

mPacket type	Notation	Frame count	Value
verify packet	SMD-V	—	0x07
respond packet	SMD-R	—	0x19
express packet	SMD-E	—	0xD5
preemptable packet start	SMD-S0	0	0xE6
	SMD-S1	1	0x4C
	SMD-S2	2	0x7F
	SMD-S3	3	0xB3
continuation fragment	SMD-C0	0	0x61
	SMD-C1	1	0x52
	SMD-C2	2	0x9E
	SMD-C3	3	0x2A

Redefined Preamble

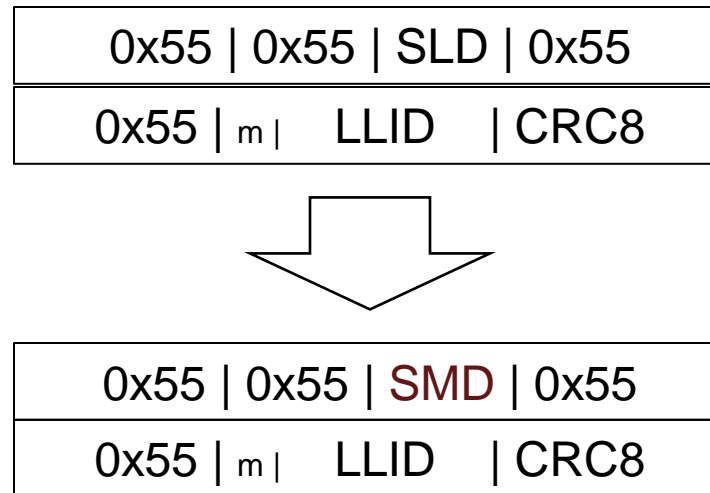

- Burst start
- Frame start
- Fragment end
- Fragment start
- Frame end
- Burst end

- Redefine SLD to include:
 - Frame Start
 - Fragment Start
- Burst always begins with Frame Start or Fragment Start

Endings

- Fragments end with mCRC
- Frames end with FCS
- Bursts end with mCRC or FCS

- Burst start
- Frame start
- Fragment end
- Fragment start
- Frame end
- Burst end

We Fight

- Current thinking has been entire frame is sent to a single lane
 - This made sense without fragmentation
 - Aligning bursts was difficult & potentially wasteful of transmission capacity
- Should we reconsider striping frames across lanes?
 - Bursts from all ONUs easily aligned with fragmentation
 - Truly achieves 100Gb/s transmission
 - Eliminates frame reordering issues



Other thoughts?



THANKS