

Security Level:

# 25G/50G dual rate channels

Dekun Liu

[www.huawei.com](http://www.huawei.com)

# Background

- Based on the analysis in liu\_3ca\_3\_0917 PON evolution should :
  - Leverage the “Hand-me-down effect” of device platform in Ethernet ecosystem
  - Reach the serial rate limitation with TDM first, and then do WDM
- 50Gb/s per lane is widely adopted in 200G and 400G Ethernet for data center and will have cost advantage compared with multiple channels when 50Gb/s technology becomes mature in mid term future
- Smooth evolution from 25G PON to 50G PON is very important for the operators to protect the investment
- 25G OLT may be a too small step from 10G for some operators , but 25G ONUs are still a good choice due to ONUs are deployed based on requirement (zhang\_3ca\_1\_0716)

**From China Telecom’s point of view, most probably to evolve from 10G platform (CO) directly to 100G in the far future when necessary, and without the interim stage of 25G/50G**

## Regarding wavelength plan, 1+3 is preferred

- **1+3 wavelength plan occupies less optical spectrums and provides simplify coexistence**
  - for OLT, 10G-EPON platform → 100G-EPON platform
  - for ONU, 10G-EPON ONU → rates 25/10, 25/25, 100/25 per service types

# Evolve from 25G to 50G PON by WDM

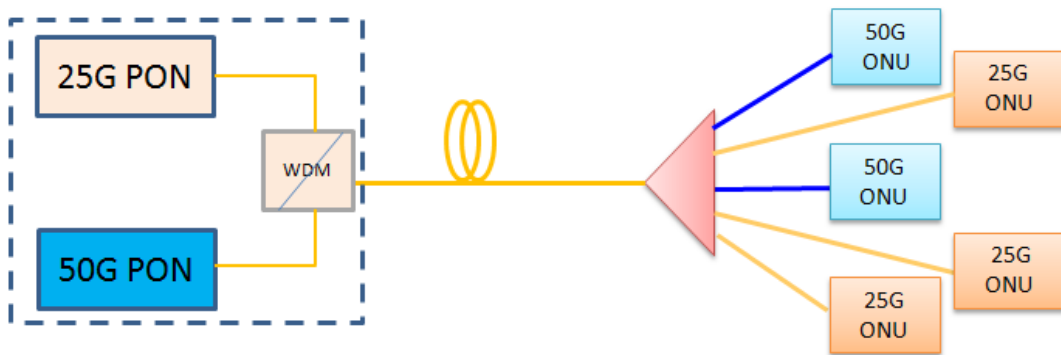

Wavelength plan example

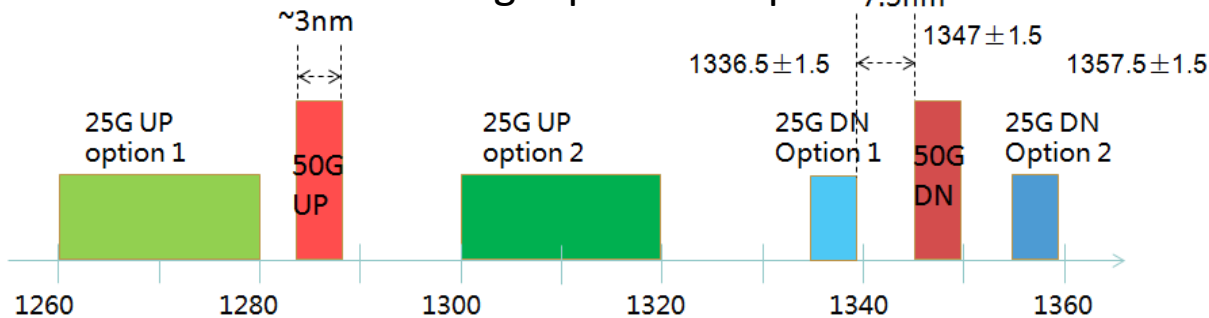

harstead\_3ca\_1a\_0716.pdf

Minimum gap before the WBF imposes significant cost and insertion loss



|                | number | mean | $\sigma$ |
|----------------|--------|------|----------|
| Min value (nm) | 4      | 11   | 7        |

- Only 50G PON OLT can't support 25G ONUs (Some operators want to skip 25G OLT but still can support 25G ONUs)
- Need to find 3 pairs wavelength, the channel width of 50G will be very narrow, and the gap between 50G DN and 25G DN will also be small, which will increase both 25G and 50G ONU cost

# Evolve to 50G by TDM dual rate

50Gb/s PON uses the same wavelength pair in 25G PON, coexist by dual rate TDM in both downstream and upstream

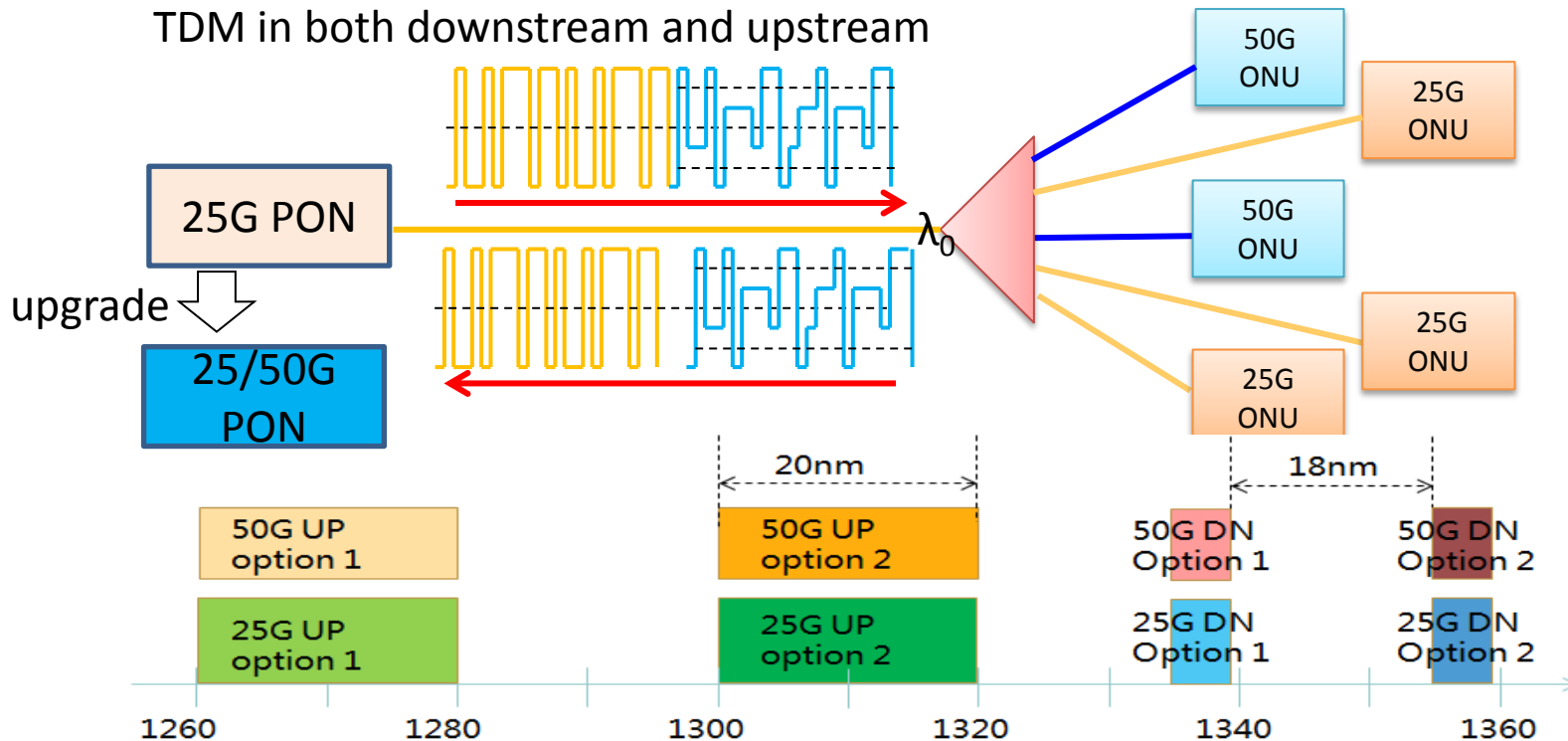

- 50G OLT can directly support 25G ONUs without deploying an interim 25G OLT
  - Different Operators can have their own decision on the upgrading step
- 50Gb/s don't bring any constraint on 25Gb/s wavelength allocation, Both 25G and 50G PON can have wide channel width
- 50Gb/s can share the 25G optics industry (same wavelength lasers and APDs, may be same bandwidth optics)

# Downstream dual rate based on PAM4

50Gb/s PON based on 25GBaud PAM4

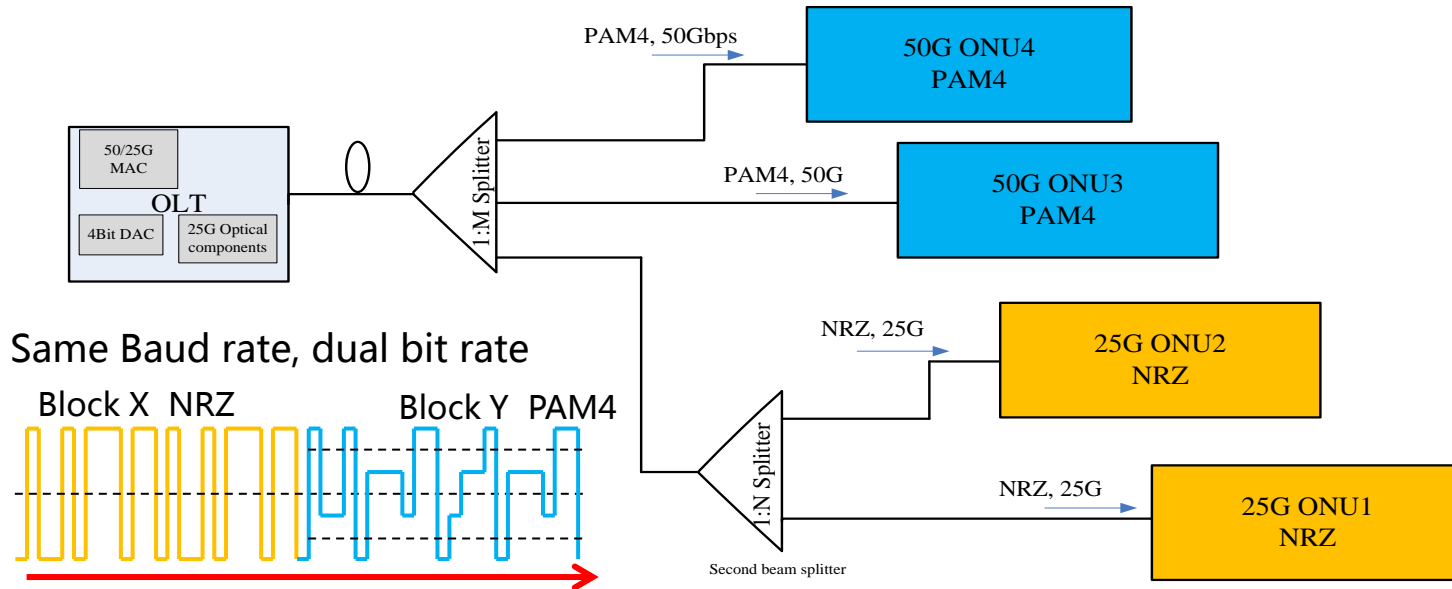

Same Baud rate, dual bit rate

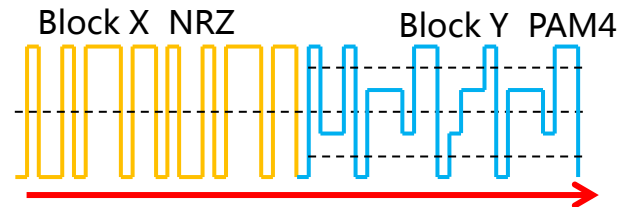

- Downstream signal is still continuous and the baud rate is always 25Gb/s
- 50G ONUs can work well with 25G NRZ signal (it' s a part of 25G PAM4)
- The CDR of 25G ONUs is always locked in 25Gb/s and keep synchronized during 50G block (PAM4)
- All the overhead are based on NRZ modulation, 25G ONUs may make wrong decision on 50G block but they are deem to be discarded by 25G ONUs.

# Downstream dual rate based on dual rate NRZ

An example high bit rate signal through a low band width receiver

50Gb/s PON based on 50G NRZ

Block X 25G NRZ Block Y 50G NRZ

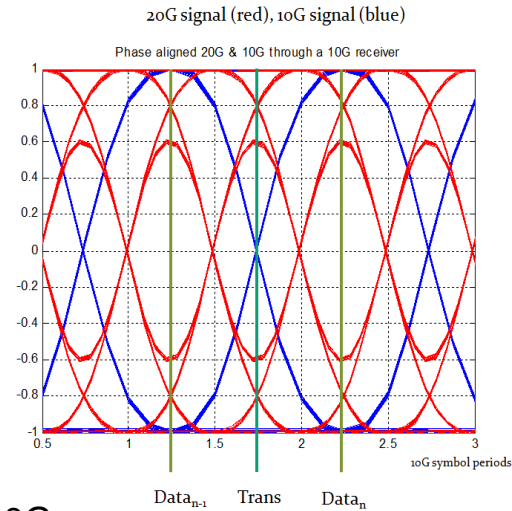
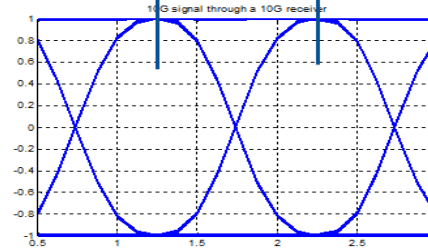
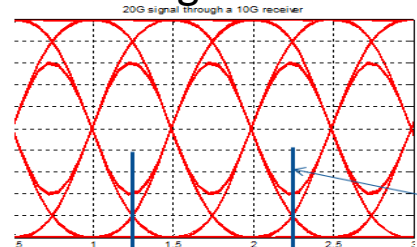
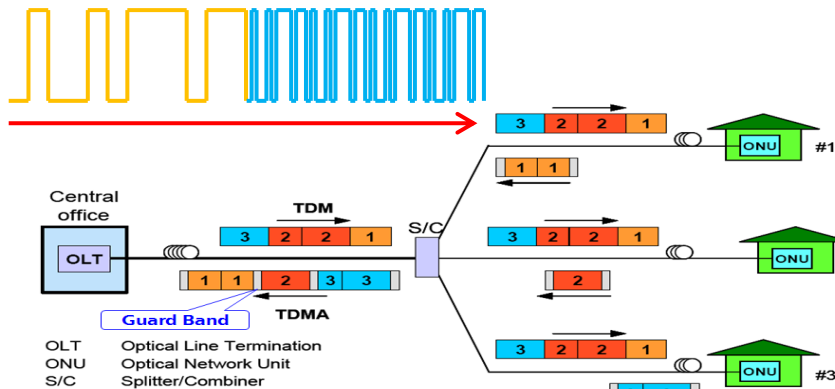

20G eye opening aligned with 10G eye opening to maintain timing

- Downstream signal is still continuous and but the baud rate is switched between 25Gb/s and 50Gb/s
- The CDR of 25G ONUs must be always locked in 25Gb/s and keep synchronized during 50Gb/s NRZ block. This is same for 50G ONUs' CDR.
- Global synchronization and 50G/25G block indication are need in the overhead.
- Feasibility of this solution needs further study and confirmation (more challenging than same baud rate in downstream based on PAM4)

# Protocol adaption (Downstream)

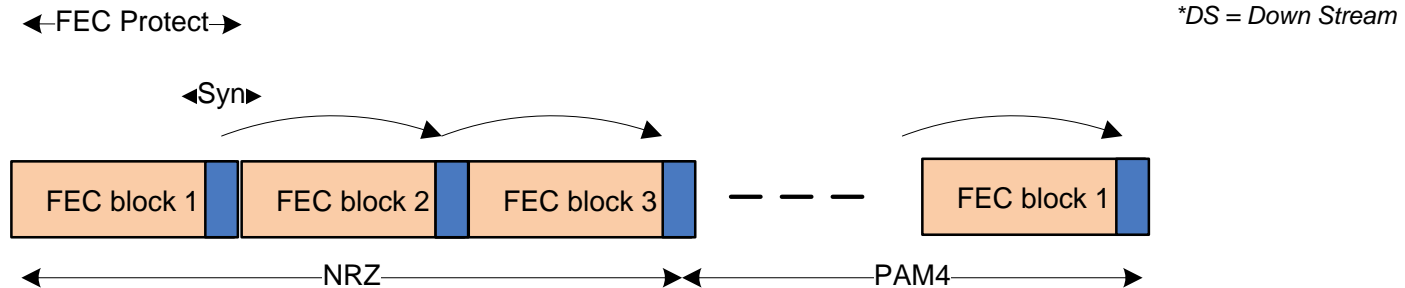

- All the overhead can be based on NRZ modulation (25G ONUs can still recognize the overhead of 50G blocks)
- FEC blocks for 25G (NRZ) and 50G (PAM4) should be separated and independent, 25G ONUs should completely discard the 50G blocks
- Global 50G/25G blocks indication are needed in the protocol.
- **25G ONUs should be aware in advance** that some blocks in downstream may belong to 50G ONUs

# Dual rate for upstream

Multiple rate receiver OLT

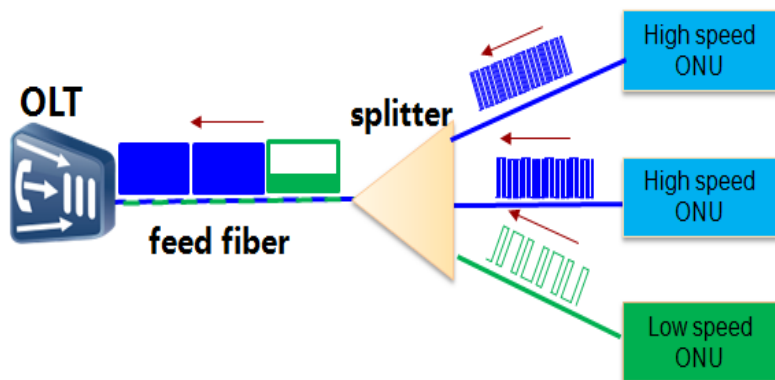

Different implementations for multiple rate receiver

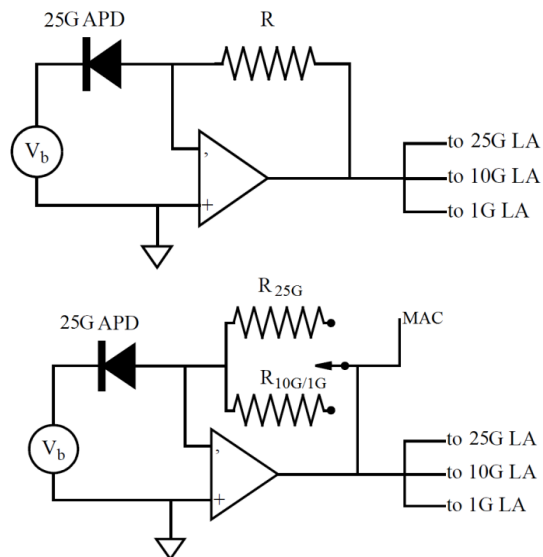

- Dual rate upstream technology is quite mature in nowadays.
- Even more rate, such as triple rate, is also feasible from technical without noticeable impact on previous generation ONUs.
- Whatever modulation format of 50Gb/s , PAM4 or NRZ, dual rate for upstream is OK and without any impact on ONUs



# Summary

- 25G and 50G dual rate channels can help the operators smoothly evolve from 25Gb/s to 50Gb/s PON
  - Different Operators can have their own decision on the upgrading step without noticeable extra cost
- 25G and 50G dual rate channels can help us allocate the 25G PON wavelength more freely
  - More wavelength source are available
- 25G and 50G dual rate is feasible in technical
  - Upstream dual rate is quite mature
  - Downstream dual rate based on PAM4 shows no serious technical concerns
  - Downstream dual rate based on dual rate NRZ seems still possible
- It's recommended that the task force make further study on 25G/50G dual rate and see if it can be an evolution way from 25Gb/s PON to 50Gb/s PON

**Thank you**  
[www.huawei.com](http://www.huawei.com)