

---

# 162B.1 Mated Test Fixtures Specifications

Chris DiMinico  
MC Communications/PHY-SI LLC/Panduit  
[cdiminico@ieee.org](mailto:cdiminico@ieee.org)

# Purpose

---

- **Proposals for 162B.1 Mated Test Fixtures specification**
- **Provide specifications for TBDs;**
  - **162B.1.3.1 Mated test fixtures differential insertion loss Equation (162B–3) and Equation (162B–5).**
  - **162B.1.3.3 Mated test fixtures common-mode conversion insertion loss Equation (162B–8).**
  - **162B.1.3.4 Mated test fixtures common-mode return loss (162B–9).**
  - **162B.1.3.5 Mated test fixtures common-mode to differential mode return loss Equation (162B–10).**

# Mated test fixtures

## 162B.1 Test fixtures

Transmitter and receiver measurements at TP2 or TP3 for the 100GBASE-CR1, 200GBASE-CR2, and 400GBASE-CR4 host form factors (see Annex 162D) and at TP1a or TP4a for the 100GAUI-1, 200GAUI-2, and 400GAUI-4 C2M hosts (see Annex 120G), are made utilizing the test fixture specified in 162B.1.3. Cable assembly measurements for the cable assembly form factors (see Annex 162D) are made between TP1 and TP4 with test fixtures as specified in 162B.1.3 on both ends. The test fixtures are specified in a mated state to enable connections to measurement equipment. The reference insertion loss of the mated test fixtures is 6.6 dB at 26.56 GHz using Equation (162B-5). The requirements in the referenced subclauses are not the MDI connector specifications for an implemented design.

**Table 162C-1—Number of PMDs supportable for each connector type**

MDI types	100GBASE-CR1	200GBASE-CR2	400GBASE-CR4	Reference
SFP112	1	—	—	162C.2.1
QSFP112	1, 2, 4	1, 2	1	162C.2.2
QSFP112-DD	1, 2, 4, 8	1, 2, 4	1, 2	162C.2.3
OSFP	1, 2, 4, 8	1, 2, 4	1, 2	162C.2.4
SFP112-DD	1,2	1	—	162C.2.5
DSFP	1, 2	1	—	162C.2.6

# 162B.1.1 Mated test fixtures

- Test Fixture specifications – Adopted– referenced parameters 26.56 GHz  
 $f=0.01 \leq f \leq 40$  (signaling rate 53.125 GBd).

## Mated test fixtures parameters

Parameter description	Value	Unit
Maximum differential insertion Loss	Equation(TBD)	dB
Minimum differential Insertion Loss	Equation(TBD)	dB
Reference differential insertion loss	Adopted	dB
Figure of Merit(FOM) ILD	Equation(TBD)	dB
Minimum Differential Return Loss	Equation(TBD)	dB
Common-mode conversion insertion loss	Equation(TBD)	dB
Common-mode return loss	Equation(TBD)	dB
Common-mode to differential –mode return loss	Equation(TBD)	dB
Integrated crosstalk noise	(TBD)	mV

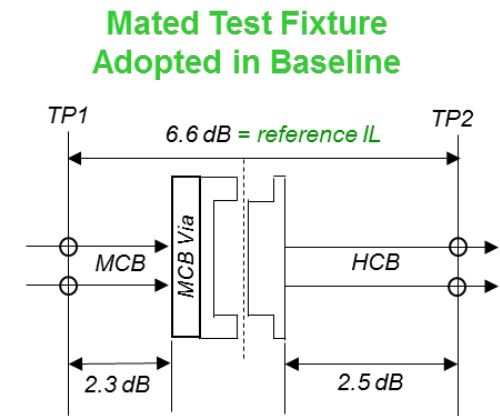

Note: 2.3 dB MCB PCB includes test point IL  
 and MCB Via allowance is 0.2 dB

# Mated Test Fixtures

Measurements with compliant PCB IL - HCB and MCB

## Mated Test Fixture Adopted in Baseline

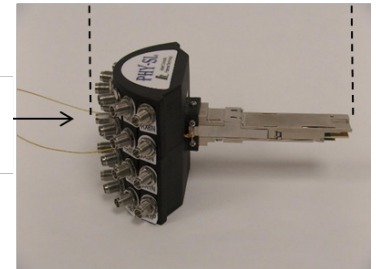
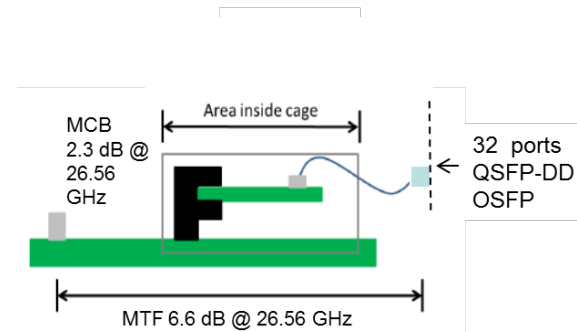
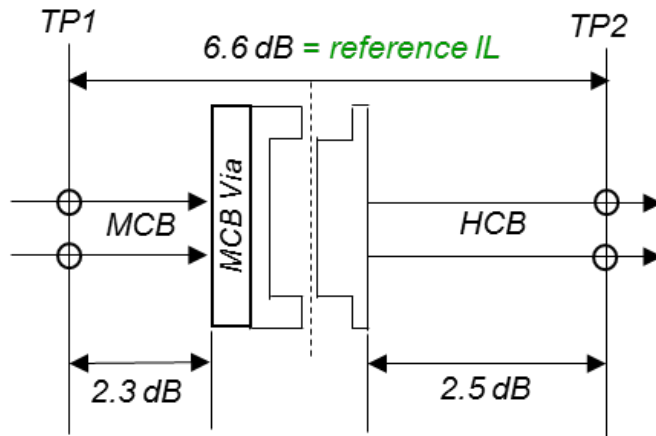

Note: 2.3 dB MCB PCB includes test point IL  
and MCB Via allowance is 0.2 dB

# Mated test fixture Max and Min IL

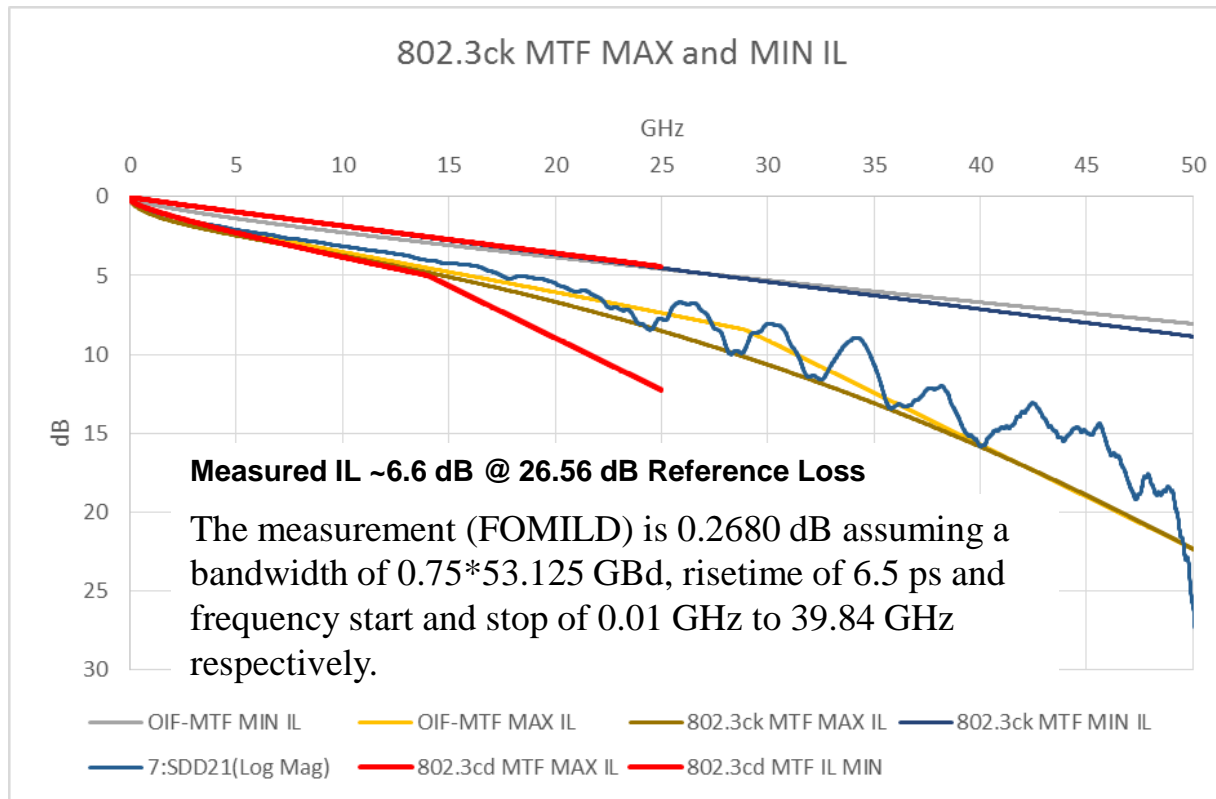

**Maximum differential insertion Loss =**

$$1.185 \cdot \text{SQRT}(f_{\text{GHz}}) - 0.072 \cdot f_{\text{GHz}} + 0.007 \cdot f_{\text{GHz}}^2$$

$f = 0.01 \text{ GHz} \leq f \leq 40 \text{ GHz}$

**Minimum differential Insertion Loss=**

$$1.0225 \cdot (0.0656 \cdot \text{SQRT}(f_{\text{GHz}}) + 0.164 \cdot f_{\text{GHz}})$$

$f = 0.01 \text{ GHz} \leq f \leq 40 \text{ GHz}$

**OIF Mated Test Fixtures Min and Max**

- MTF MIN (IL) =  $0.00234 - 0.3784 \cdot \sqrt{f} - 0.10764 \cdot f$  (dB)
- MTF MAX (IL) =  $-0.7114 \cdot \sqrt{f} - 0.1073 \cdot f - 0.0018 \cdot f^2$  (dB)  $50\text{MHz} < f \leq 29\text{GHz}$
- MTF MAX (IL) =  $10.683 - 0.66 \cdot f$  (dB)  $29\text{GHz} < f < 58\text{GHz}$

# MTF Differential Return Loss

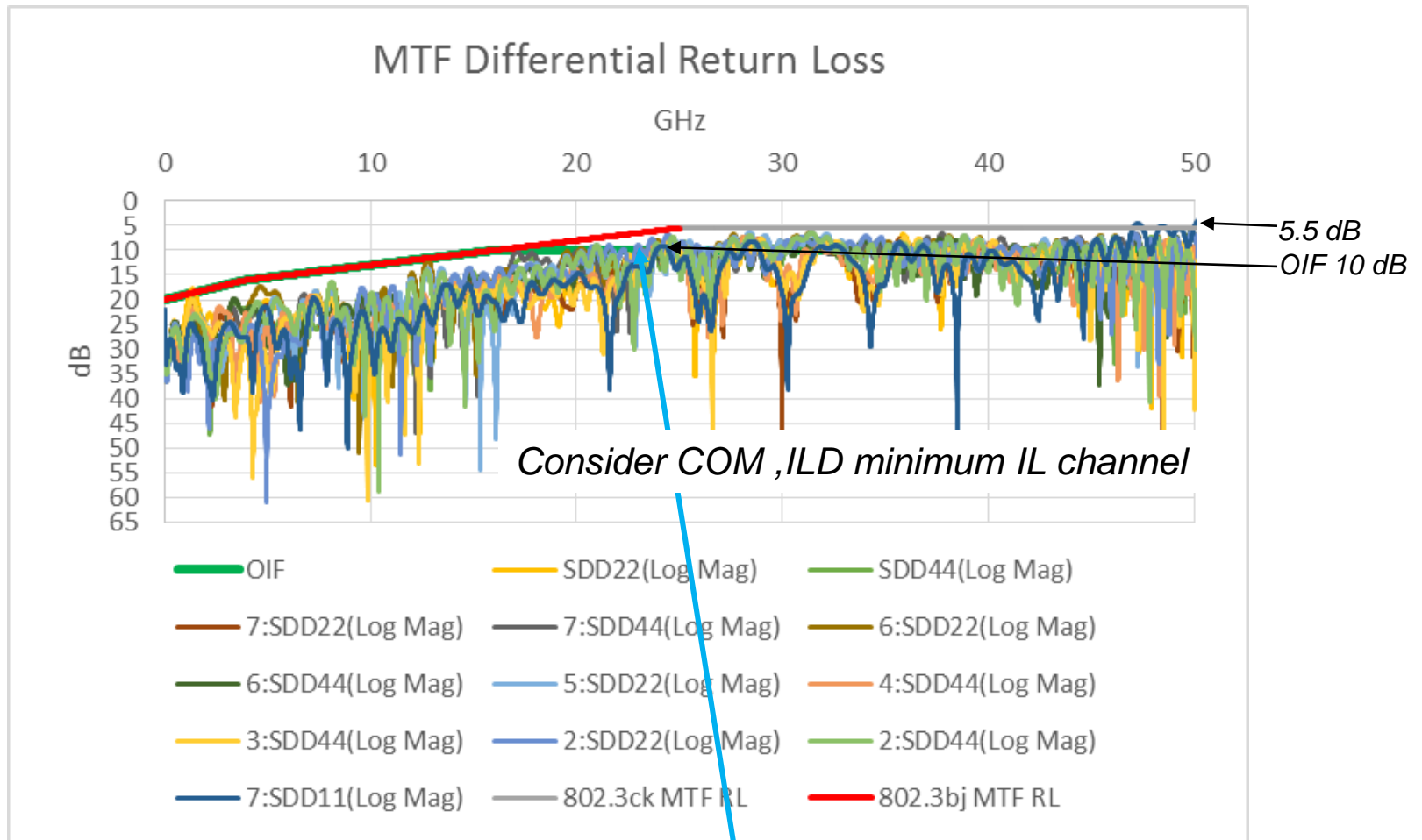

## Differential Return Loss =

**20-f<sub>GHz</sub>**    **0.01 GHz ≤ f<sub>GHz</sub> < 4 GHz**

**18-0.5\*f<sub>GHz</sub>**    **4 GHz ≤ f<sub>GHz</sub> < 25 GHz**

**5.5**    **25 GHz ≤ f<sub>GHz</sub> < 40 GHz**

## OIF Mated Test Fixtures Return Loss

- MTF MIN (DRL) = -20+f (dB) 50MHz < f < 4GHz
- MTF MIN (DRL) = -18+f/2 (dB) 4GHz < f < 16GHz
- MTF MIN (DRL) = -10 (dB) 16GHz < f < 48GHz

# MTF Common to Differential Mode Return Loss

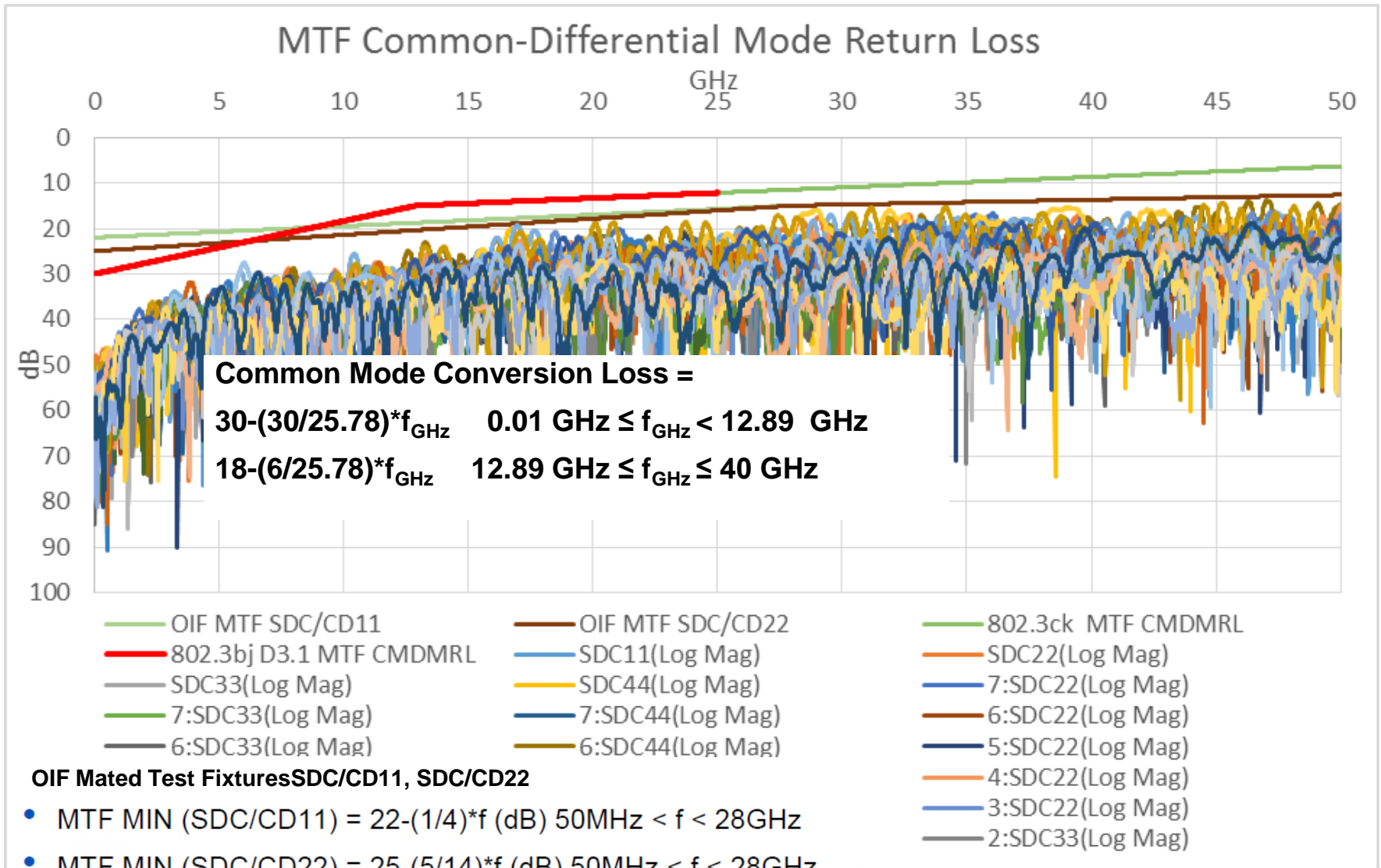



# MTF Common Mode Conversion Loss

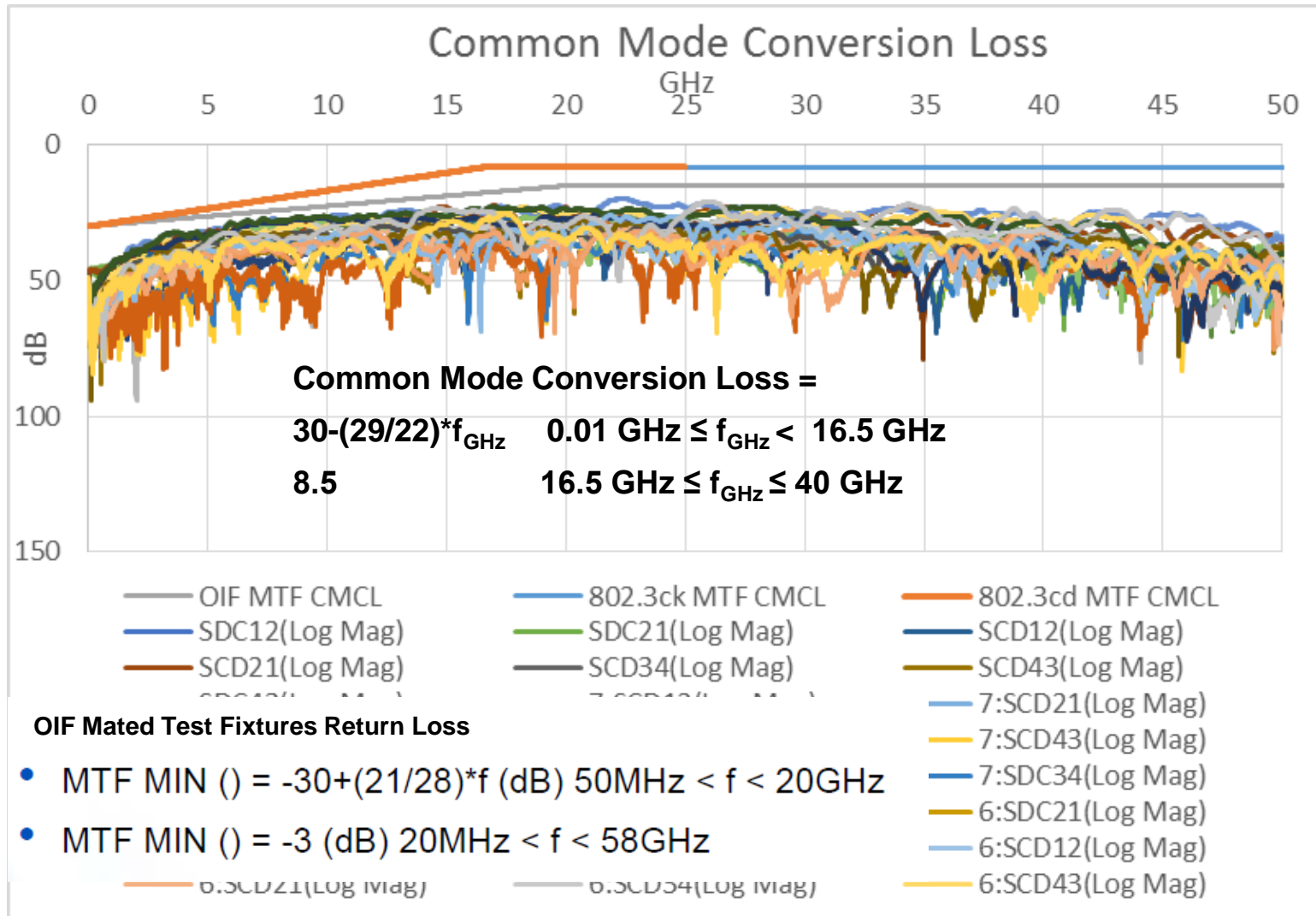

# MTF Common Mode Return Loss

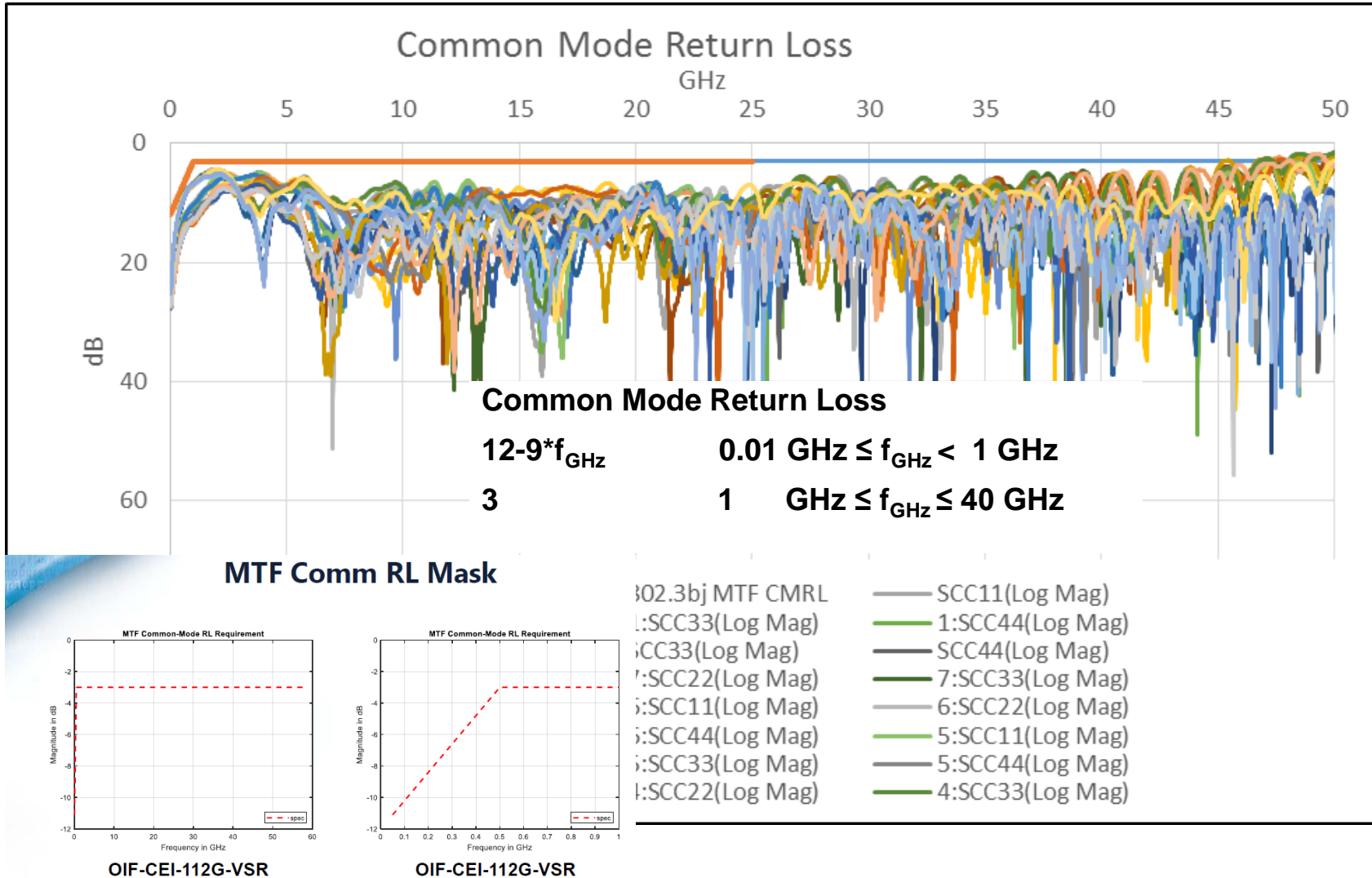

- Equations:
- MTF MIN (CMRL) =  $-12 + 18 \cdot f$  (dB)  $50\text{MHz} < f < 500\text{MHz}$
- MTF MIN (CMRL) =  $-3$  (dB)  $500\text{MHz} < f < 58\text{GHz}$

# 162B.1.1.6 Mated test fixtures (ICN) Tables

Description	Symbol	Value	Units
Symbol rate	$f_b$	53.125	GBd
3dB reference receiver bandwidth	$f_r$	39.84	GHz
Near-end disturber peak differential output amplitude	$A_{nt}$	600	mV
Far-end disturber peak differential output amplitude	$A_{ft}$	600	mV
Near-end disturber 20% to 80% rise and fall times	$T_{nt}$	TBD	ps
Far-end disturber 20% to 80% rise and fall times	$T_{ft}$	TBD	ps