

# Super-PON PMD Refinements

IEEE P802.3cs, June 4, 2020  
Liang Du (Google)

# Overview

- 2020 May 28 teleconference
  - Suggested residual CD tolerances of -600 ps/nm to 50 ps/nm residual dispersion for ONT transmitters (upstream) at 2-dB penalty
  - Suggested residual CD tolerances of 0 ps/nm to 900 ps/nm residual dispersion for OLT transmitters (downstream) at 1-dB penalty
  - Showed an example black link with key component details
  - Corrected OSNR calculation for 10G upstream
- This teleconference
  - Revised downstream CD tolerance based on new information provided by Vince (Corning)
  - Revised upstream DCM values based on new information provided by Vince (Corning)
  - Correction on OSNR calculation for 2.5G upstream and minimum OSNR for 10G

# Residual CD for US direction

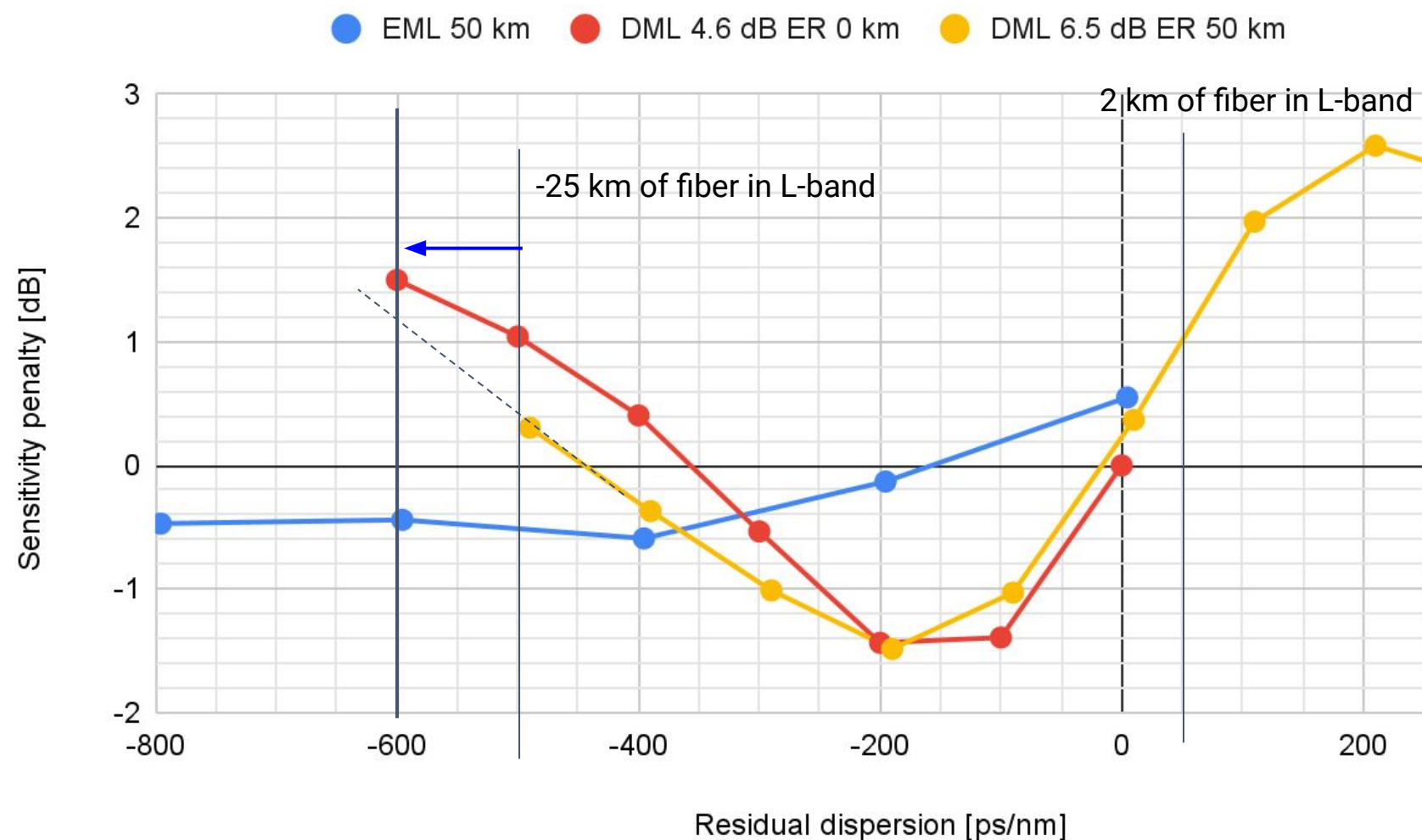

Ignore 4.6 dB ER DML line to expand range

DML at 6.5 dB ER allows for operation down to -600 ps/nm

Can adjust the laser to be more negatively chirped for better residual dispersion performance

650 ps/nm is 32.5 km

# Linear interpolation of CD values (Vince - Corning)

Reference CD values from Corning [ps/nm/km]			
Wavelength [nm]	Min values	midpoint	Max values
1550	16.7	17.05	17.4
1625	21.2	21.6	21.8
Calculations			
m	0.060	0.061	0.059
c	-76.300	-76.983	-73.533
CD for key Super-PON wavelengths (using full 20 channels) [ps/nm/km]			
Wavelength [nm]	Min values	midpoint	Max values
1599.59	19.68	20.06	20.31
1583.91	18.73	19.11	19.39
1563.05	17.48	17.84	18.17
1547.72	16.56	16.91	17.27

# Residual CD tolerances

Residual dispersion [ps/nm]				
Distance [km]	C-band min	C-band max	L-band min	L-band max
0	0	0	0	0
25	414.1	454.1	468.4	507.7
30	496.9	545.0	562.0	609.3
50	828.2	908.3	936.7	1015.5

Update DS residual CD tolerance to 910 ps/nm

# ONU transmit

Current parameters (current draft)	New parameters (proposal)	Current values (in draft)		
Parameter	Parameter	10GBASE-SP1-Ux	10/2.5GBASE-SP1-Ux	Unit
Signaling speed (range)	Signaling speed (range)	10.3125 ± 100 ppm	2.578125 ± 100 ppm	GBd
Channel center frequencies	Channel center frequencies	L-band 1 (upstream)		THz
Maximum spectral excursion (after turn-on time)	Maximum spectral excursion (after turn-on time)	± 15		GHz
Maximum mean channel output power	Maximum mean channel output power	8	4.5	dBm
Minimum mean channel output power	Minimum mean channel output power	see equation xx	-0.5	dBm
Minimum side-mode suppression ratio (SMSR)	Minimum side-mode suppression ratio (SMSR)	38		dBm
Minimum channel extinction ratio	Minimum channel extinction ratio	see equation xx	6	dB
Transmitter eye mask definition {X1, X2, X3, Y1, Y2, Y3}	Transmitter eye mask definition {X1, X2, X3, Y1, Y2, Y3}	{0.25, 0.4, 0.45, 0.25, 0.28, 0.4}		UI
Maximum transmitter (residual) dispersion OSNR penalty -400 to +200 ps/nm residual CD -400 to +1000 ps/nm residual CD	Maximum transmitter (residual) dispersion OSNR penalty -600 to +50 ps/nm residual CD -600 to +1000 ps/nm residual CD	2.0	1.0	dB
Average launch power of OFF transmitter (max)	Average launch power of OFF transmitter (max)	-45		dBm
RIN <sub>15</sub> OMA (max)	RIN <sub>15</sub> OMA (max)	-128		dB/Hz
Turn-on time (max)	Turn-on time (max)	512		ns
Turn-off time (max)	Turn-off time (max)	512		ns

# Correction on previously presented OSNR calc

- **Previous** US OSNR calculation

- $OSNR = 58 + P(\text{fiber input}) - NF - L(\text{span}) - \log(\#\text{spans})$   
 $OSNR = 58 + 4 - 6 - 41 - \log(1)$   
 $OSNR = 15 \text{ dB}$

- **Corrected** US OSNR calculation

- $OSNR = 58 + P(\text{fiber input}) - NF - L(\text{span}) - \log(\#\text{spans})$   
 $OSNR = 58 + 4 - 6 - 41 - 1 - \log(1)$   
 $OSNR = 14 \text{ dB}$

Loss of the band-mux. This is not part of the link budget calculation but is between the ONU and the EDFA

# OLT receive

Parameter	Current draft values		Updated values for next draft		Unit
	10GBASE-SP1-Dx	10/2.5GBASE-SP1-Dx	10GBASE-SP1-Dx	10/2.5GBASE-SP1-Dx	
Signaling speed (range)	10.3125 ± 100 ppm	2.578125 ± 100 ppm	10.3125 ± 100 ppm	2.578125 ± 100 ppm	GBd
Channel frequency range	187.600 to 189.092		187.600 to 189.092		THz
Bit error ratio (max)	10 <sup>-2</sup>		10 <sup>-2</sup>		
Maximum mean input power	-6		-6		dBm
Minimum mean input power	-20.6	-25.1	-20.6	-25.1	dBm
Minimum OSNR	15	10.5	14	9.5	dB (0.1 nm)
Receiver OSNR tolerance	12.9	8.4	11.9	8.4	dB (0.1 nm)
Receiver reflectance (max)	-12		-12		dB
Damage Threshold	-5		-5		dBm
Signal detect threshold (min)	-45		-45		dBm
Treceiver_settling (max)	800		800		ns

This was not updated last meeting. Oversight.

Rx OSNR only determined by link and Tx output power  
The lower allowed Tx penalty is reflected in the Rx OSNR tolerance.



# OLT transmit

<b>Current parameters (current draft)</b>	<b>New parameters (proposal)</b>	<b>Current values (in draft)</b>	
<b>Parameter</b>	<b>Parameter</b>	<b>10GBASE-SP1-Dx 10/2.5GBASE-SP1-Dx</b>	<b>Unit</b>
Signaling speed (range)	Signaling speed (range)	10.3125 ± 100 ppm	GBd
Channel center frequencies	Channel center frequencies	C-band 1 (downstream)	THz
Maximum spectral excursion	Maximum spectral excursion	± 15	GHz
Maximum mean channel output power	Maximum mean channel output power	1.5	dBm
Minimum mean channel output power	Minimum mean channel output power	-2.5	dBm
Minimum side-mode suppression ratio (SMSR)	Minimum side-mode suppression ratio (SMSR)	35	dB
Minimum channel extinction ratio	Minimum channel extinction ratio	8.2	dB
Transmitter eye mask definition {X1, X2, X3, Y1, Y2, Y3}	Transmitter eye mask definition {X1, X2, X3, Y1, Y2, Y3}	{0.25, 0.4, 0.45, 0.25, 0.28, 0.4}	UI
Transmitter and dispersion penalty (TDP) @ 0 to 1000 ps/nm residual CD	Transmitter and dispersion penalty (TDP) 0 to 910 ps/nm residual CD	1.0	dB
RIN <sub>15</sub> OMA (max)	RIN <sub>15</sub> OMA (max)	-120	dB/Hz
Average launch power of OFF transmitter (max)	Average launch power of OFF transmitter (max)	-39	dBm
Optical return loss tolerance (max)	Optical return loss tolerance (max)	15	dB

Updated based on data provided by Vince.

# Black link: OLT to ONU

	<b>Current values (in draft)</b>	<b>Proposed values</b>	
<b>Parameter</b>	<b>10 Gb/s</b>	<b>10 Gb/s</b>	<b>Unit</b>
Clear link passband	±15	±15	GHz
Maximum ripple (within the clear link passband)	+2	+2	dB
Maximum (residual) chromatic dispersion	+1000	+910	ps/nm
Minimum (residual) chromatic dispersion	0	0	ps/nm
Minimum optical return loss at transmitter	+20	+20	dB
Maximum discrete reflectance between transmitter and receiver			dB
Maximum differential group delay	+12	+12	ps
Maximum inter-channel crosstalk		0.1	dB
Maximum optical path power penalty	+1	+1	dB
Maximum power excursion			

# Black link: ONU to OLT

Parameter	Current values (in draft)		Proposed values		Unit
	10 Gb/s	2.5 Gb/s	10 Gb/s	2.5 Gb/s	
Clear link passband	±15				GHz
Maximum ripple (within the clear link passband)	+2				dB
Maximum (residual) chromatic dispersion	+200	+1000	+50	+1000	ps/nm
Minimum (residual) chromatic dispersion	-400	-400	-600	-600	ps/nm
Minimum optical return loss at transmitter	+20		+20		dB
Maximum discrete reflectance between transmitter and receiver					dB
Maximum differential group delay	+12		+12		ps
Maximum inter-channel crosstalk			0.1		dB
Maximum optical path OSNR penalty	2	1	2	1	dB
Maximum power excursion					dB

# Black link - downstream (informative)

## EDFA

Gain  $\geq 21$  dB  
Max power  $\geq 25$  dBm  
NF  $\leq 12$  dB

## AWG

Passband =  $\pm 15$  GHz  
inband ripple = 1 dB  
loss  $\leq 5.5$  dB  
Temp range: 0 to 40 C

## TFF

Passband = 1.6 THz  
inband ripple = 0.5 dB  
loss  $\leq 1.0$  dB

## AWG

Passband =  $\pm 15$  GHz  
inband ripple = 1 dB  
loss  $\leq 4.0$  dB  
Temp range: -40 to 65 C

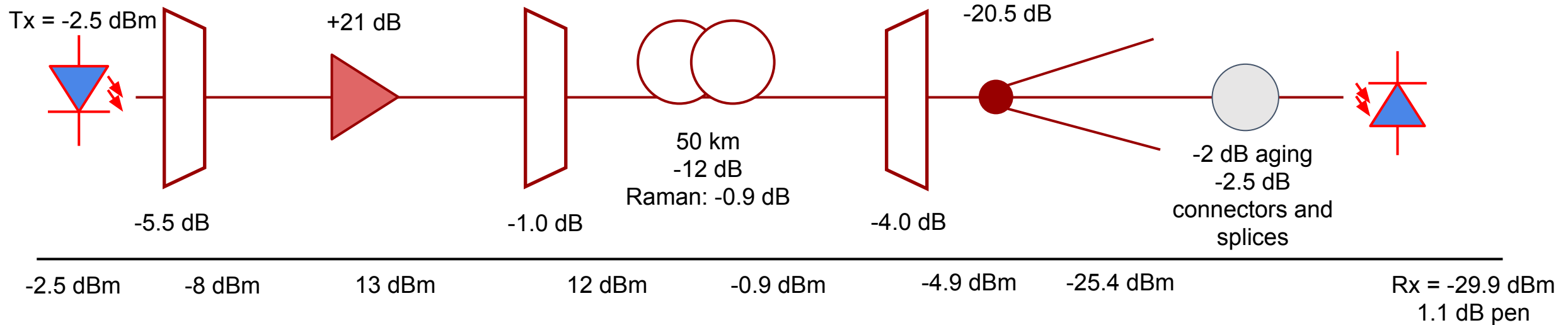

# Black link - upstream (informative)

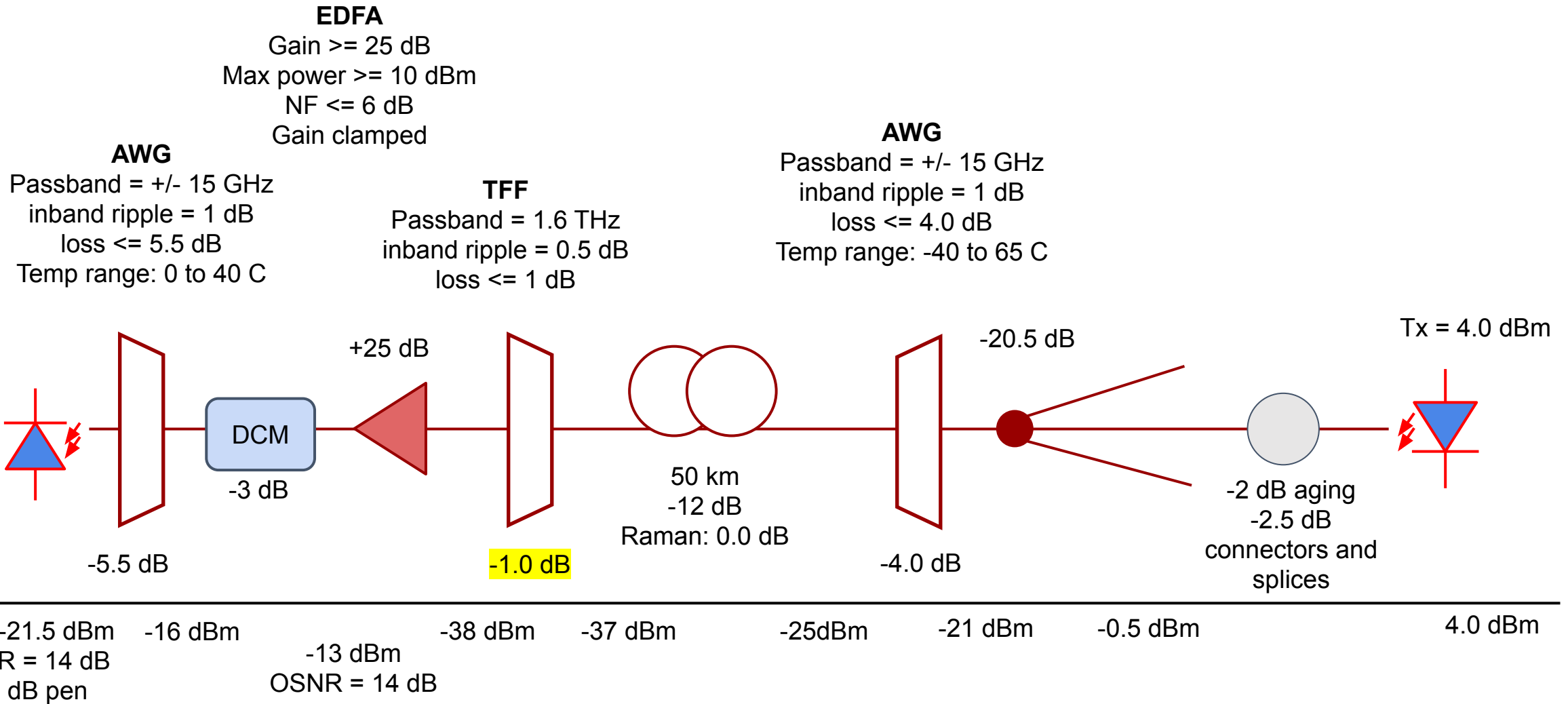

# DCM values

- Using the residual CD values from slide 5, the following table was calculated
- These values assume no slope matching

Propose -590 ps/nm for 0 - 30 km DCM.  
Closer to the zero res CD point for 30 km.  
0 km expected to have much more margin.

Acceptable DCM values for US assuming -600 to 50 residual CD [ps/nm]				
Distance [km]	Min	Max	midpoint	Range (min-max)
0-30	-559.3	-600	-579.6	40.7
25-50	-965.5	-1068.4	-1016.9	102.9

Propose -1020 ps/nm for 25 - 50 km DCM  
Close to midpoint between min and max DCM values.  
Just slightly higher than the zero res CD point for 50 km.

# Resulting min/max residual CD values

Residual CD values			
Distance [km]	DCM value	Min	Max
0-30	-590	-590	19.3
25-50	-1020	-551.6	-4.5

- Proposed DCM values keep residual CD within the proposed bounds
- Allows >5 km overlap between the low and short links. This is important for OSP planning

# Summary

- Updated the residual dispersion parameters that transmitters need to be able to tolerate. Updated relevant PMD tables.
- Corrected the US OSNR calculation. Updated the PMD table.
- Updated the Black Link tables with residual dispersion expectations
- High level recommended values for the informative components of a 50 km black link
  
- What do we do with the informative sections?



# Instructions for editor to update draft

- OLT transmit PMD table:  
Update table 200-5 according to columns 2-3 of the table on slide 9
- OLT receive PMD table:  
Update table 200-6 according to columns 3-4 of the table on slide 8
- ONU transmit PMD table:  
Update table 200-7 according to column 2 of the table on slide 6
- ONU receive PMD table (200-8): no changes
- Black link OLT to ONU PMD table:  
Update table 200-9 according to column 3 of the table on slide 10
- Black link ONU to OLT PMD table:  
Update table 200-10 according to columns 4-5 of the table on slide 11

Thank you