

# 400GBASE-FR4 Baseline Proposal

David Lewis (Lumentum)  
Hai-Feng Liu (Independent)  
Brian Welch (Cisco)

# Supporters

David Chen, AOI  
Christophe Metivier, Arista  
Shimon Muller, Axalume  
John Johnson, Broadcom  
Vasudevan Parthasarathy, Broadcom  
Rob Stone, Broadcom  
Kohichi Tamura, CIG Technologies  
Gary Nicholl, Cisco  
Pirooz Tooyserkani, Cisco  
Brian Welch, Cisco  
Vince E. Ferretti, Corning  
Jonathan King, Finisar  
Jonathan Ingham, Foxconn Interconnect Technology  
Ryou Okabe, Fujitsu  
Hideki Isono, Fujitsu Optical Components  
Jim Theodoras, HG Genuine  
Hua Zhang, Hisense Broadband  
Kevin Zhang, IDT  
Hai-Feng Liu, Independent  
Kent Lusted, Intel  
Scott Schube, Intel

Jeffery Maki, Juniper Networks  
David Ofelt, Juniper Networks  
Thananya Baldwin, Keysight  
Greg LeCheminant, Keysight  
Jerry Pepper, Keysight  
Karen Liu, Lightwave Logic  
Justin Abbott, Lumentum  
Tom Palkert, Macom  
Rich Baca, Microsoft  
Scott Sommers, Molex  
Kees Propstra, MultiLane  
David Malicoat, Senko Advanced Components  
Rang-Chen (Ryan) Yu, Sifotonics Technologies  
David Estes, Spirent  
Kenneth Jackson, Sumitomo  
Nathan Tracy, TE  
Pavel Zivny, Tektronix  
Paul Brooks, Viavi

Frank Chang, Source Photonics  
Ed Ulrichs, Source Photonics  
Zhigang Gong, O-Net  
Chongjin Xie, Alibaba  
Tom Palkert, Molex  
Mark Kimber, Semtech  
Bharat Tailor, Semtech  
Tomoo Takahara, Fujitsu Lab  
Phil Sun, Credo  
Kapil Shrikande, Innovium

# Overview

- Present a baseline proposal to address the objective of *defining a four-wavelength 400 Gb/s PHY for operation over SMF with lengths up to at least 2 km*
- Approach is based on 100G/λ transmission on four CWDM wavelength lanes using PAM4 signaling
  - Assumes FEC in 400GBASE-R PCS layer (clause 119)

# Position in IEEE 802.3 Ethernet Model

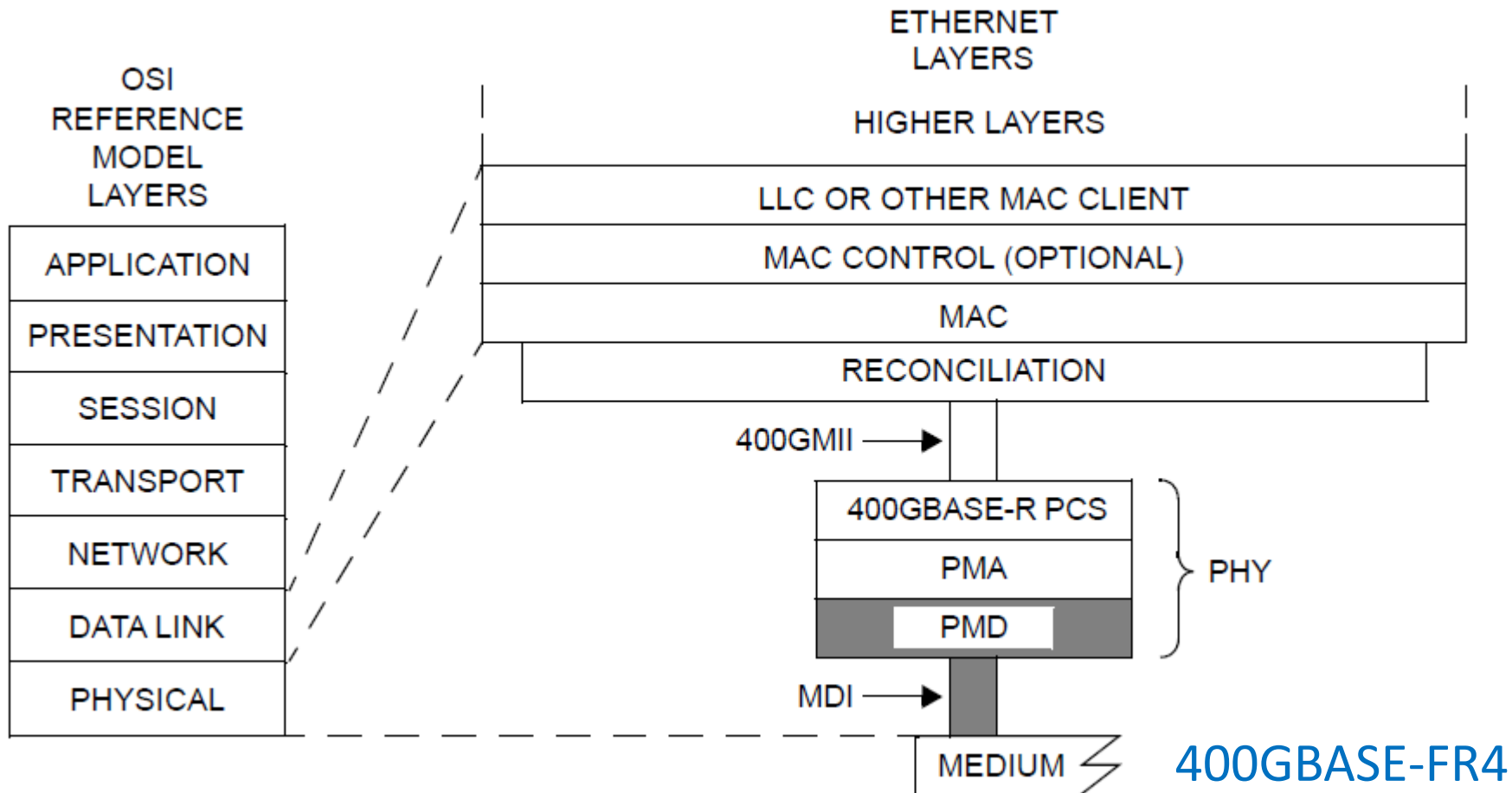

400GMII = 400 Gb/s MEDIA INDEPENDENT INTERFACE  
 LLC = LOGICAL LINK CONTROL  
 MAC = MEDIA ACCESS CONTROL  
 MDI = MEDIUM DEPENDENT INTERFACE  
 PCS = PHYSICAL CODING SUBLAYER

PHY = PHYSICAL LAYER DEVICE  
 PMA = PHYSICAL MEDIUM ATTACHMENT  
 PMD = PHYSICAL MEDIUM DEPENDENT  
 FR = PMD FOR SINGLE-MODE FIBER — 2 km

# Example PMD Block Diagram – for 2km Duplex SMF

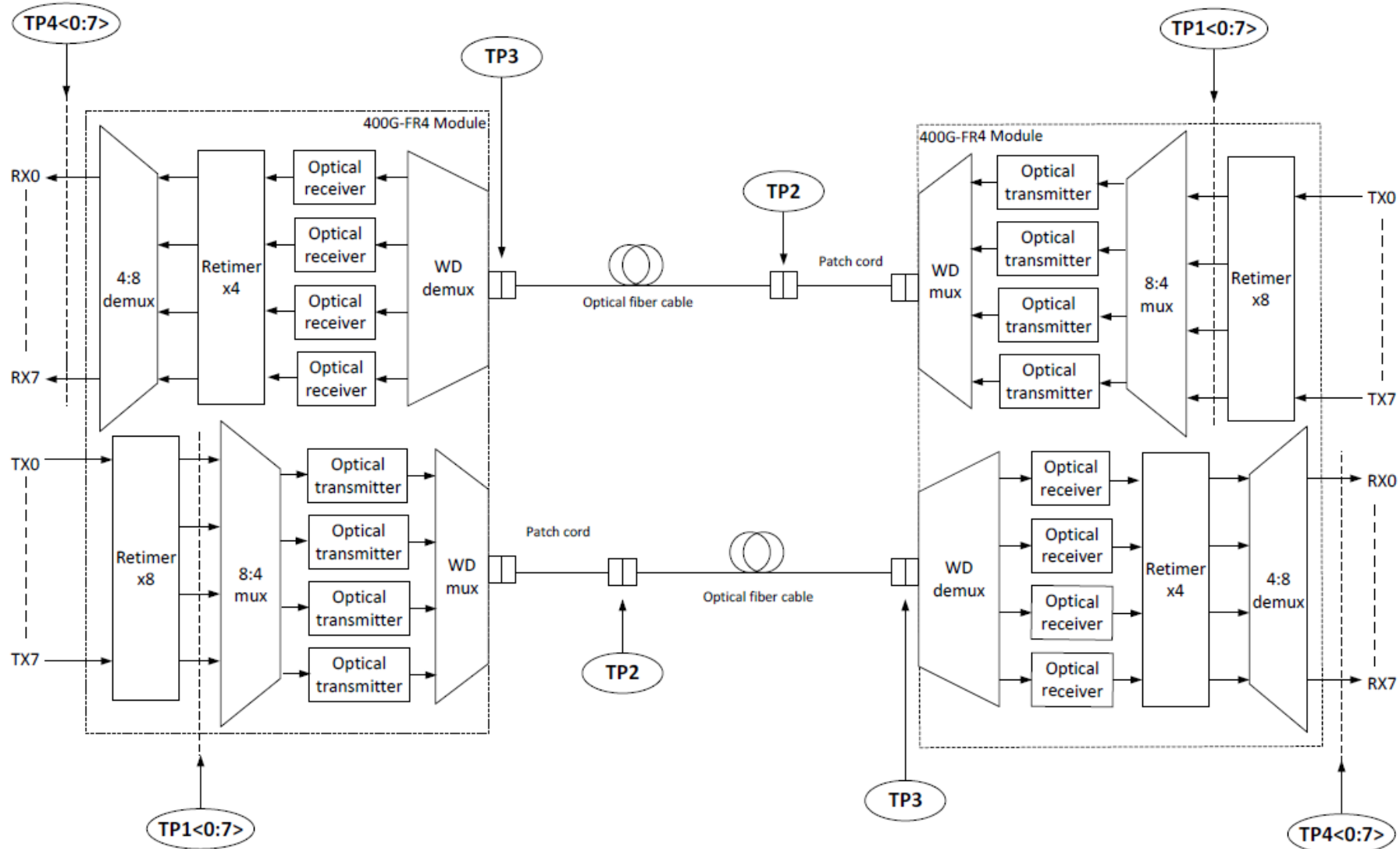

# Key Assumptions

- CWDM Wavelength Grid:

WDM Lane Assignment		
400GBASE-FR4 CWDM Lane	Center Wavelength (nm)	Wavelength Range (nm)
L0	1271	1264.5 to 1277.5
L1	1291	1284.5 to 1297.5
L2	1311	1304.5 to 1317.5
L3	1331	1324.5 to 1337.5

- 3.4 dB TDECQ as in 400GBASE-DR4
- Same FR link model for ORL calculations
- Split the 1.2 dB loss/penalty delta (relative to 400GBASE-DR4) between Tx & Rx
  - Increase Tx  $OMA_{outer}$  (min) – TDECQ by 0.5 dB
  - Lower max. SRS ( $OMA_{outer}$ ) by 0.7 dB

# 4λ x 100G Optical Transmitter Specifications

Description	400GBASE-FR4	Unit
PAM4 Signaling rate, each lane (range)	53.125 ± 100 ppm	GBd
Lane wavelengths (range)	1264.5 to 1277.5 1284.5 to 1297.5 1304.5 to 1317.5 1324.5 to 1337.5	nm
Side-mode suppression ration (SMSR), (min)	30	dB
Total average launch power (max.)	9.5	dBm
Average launch power, each lane (max)	3.5	dBm
Average launch power, each lane (min)	-3.3	dBm
Outer Optical Modulation Amplitude (OMA <sub>outer</sub> ), each lane (max)	3.7	dBm
Difference in launch power between any two lanes (OMA <sub>outer</sub> ) (max)	4	dB
Outer Optical Modulation Amplitude (OMA <sub>outer</sub> ), each lane (min)*	-0.3	dBm
Launch power in OMA <sub>outer</sub> minus TDECQ, (min) for ER ≥ 4.5 dB	-1.7	dBm
for ER < 4.5 dB	-1.6	dBm
Transmitter & dispersion eye closure for PAM4 (TDECQ), each lane (max)	3.4	dB
TDECQ – 10*log <sub>10</sub> (C <sub>eq</sub> ), each lane (max)	3.4	dB
Average launch power of Off transmitter, each lane (max)	-20	dBm
Extinction ratio, each lane (min)	3.5	dB
Transmitter transition time (ps)	17	ps
RIN <sub>17.1</sub> OMA (max)	-136	dB/Hz
Optical return loss tolerance (max)	17.1	dB
Transmitter reflectance (max)	-26	dB

\*Even if TDECQ < 1.4 dB, the OMA<sub>outer</sub> (min) must exceed this value

# 4λ x 100G Optical Receiver Specifications

Description	400GBASE-FR4	Unit
PAM4 Signaling rate, each lane (range)	53.125 ± 100 ppm	GBd
Lane wavelength (range)	1264.5 to 1277.5 1284.5 to 1297.5 1304.5 to 1317.5 1324.5 to 1337.5	nm
Damage threshold, each lane	4.5	dBm
Average receive power, each lane (max)	3.5	dBm
Average receive power, each lane (min)	-7.3	dBm
Receive power ( $OMA_{outer}$ ), each lane (max)	3.7	dBm
Difference in receive power between any two lanes ( $OMA_{outer}$ ) (max)	4.1	dB
Receiver reflectance (max)	-26	dB
Receiver sensitivity ( $OMA_{outer}$ ), each lane (max)	Max (-4.6, $SECQ - 6.0$ )	dBm
Stressed receiver sensitivity ( $OMA_{outer}$ ) (max)	-2.6	dBm
Conditions of stressed receiver sensitivity test:		
Stressed eye closure for PAM4 (SECQ), lane under test	3.4	dB
SECQ – 10*log10( $C_{eq}$ ), lane under test (max)	3.4	dB
$OMA_{outer}$ of each aggressor lane	1.5	dBm



# 400GBASE-FR4 Receiver Sensitivity Mask

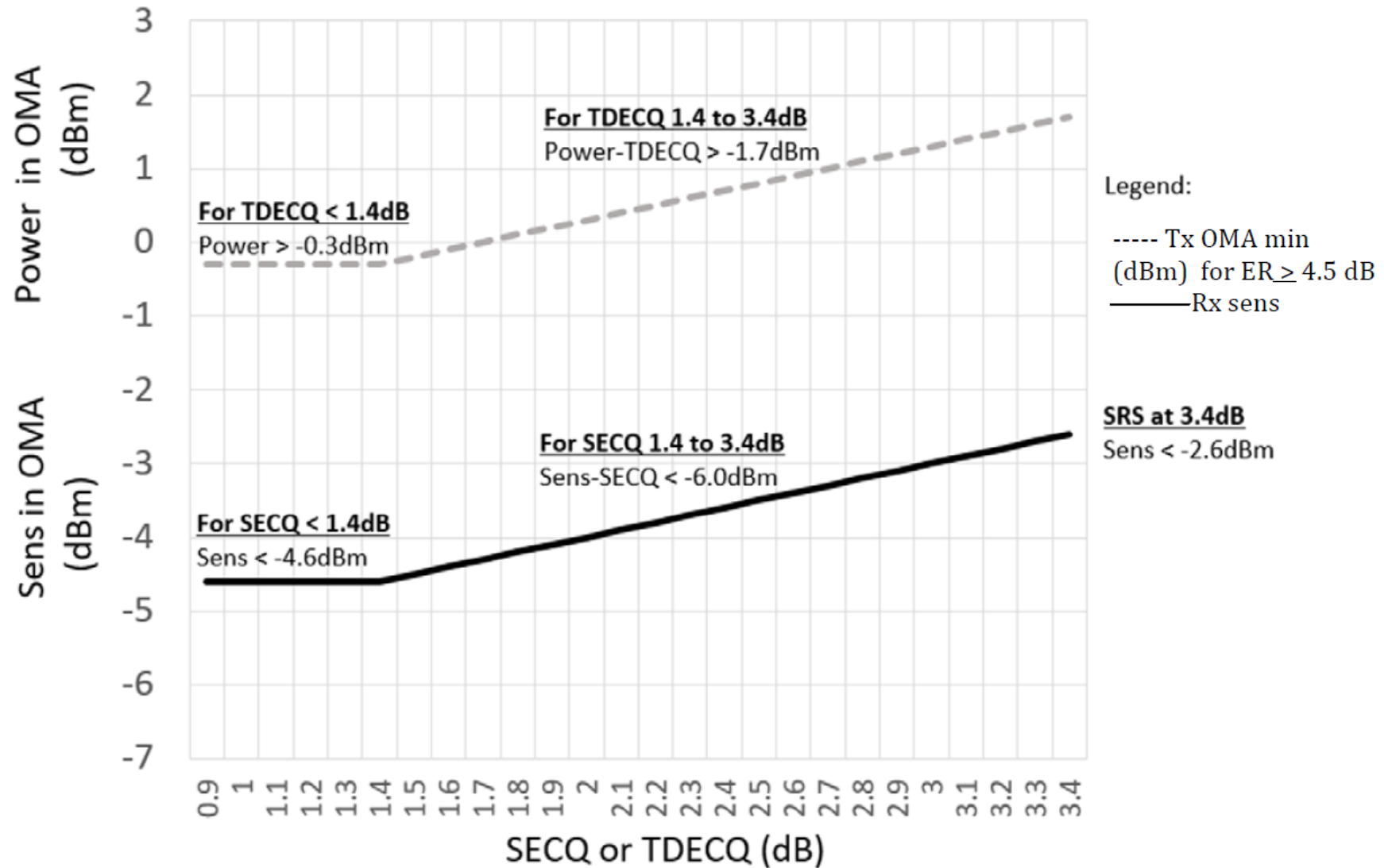

# Illustrative Optical Link Budget

Description	400GBASE-FR4	Unit
Power budget (for max TDECQ) for ER $\geq$ 4.5 dB for ER < 4.5 dB	7.7 7.8	dB
Operating distance	2	km
Channel insertion loss	4	dB
Maximum discrete reflectance	See Table below	dB
Allocation for penalties (for max TDECQ) for ER $\geq$ 4.5 dB for ER < 4.5 dB	3.7 3.8	dB
Additional insertion loss allowed	0	dB

**Table — Maximum value of each discrete reflectance**

Number of discrete reflectances above -55 dB	Maximum value for each discrete reflectance
1	-25 dB
2	-31 dB
4	-35 dB
6	-38 dB
8	-40 dB
10	-41 dB

# Thank You