

An Updated, High-Radix Switch Oriented, Fitted COM PKG Model

Richard Mellitz – Samtec

Adee Ran – Cisco systems

Liav Ben-Artzi – Marvell Technology

Contributor: Noam Kutscher – Marvell Technology

Agenda

- High-Radix Ball-out concept and resulting package
- Package material losses
- COM fitted model
- Comparison COM runs & results
- Conclusion and recommendations

Supporters

- ❑ Ali Ghiasi - Ghiasi Quantum LLC
- ❑ Rick Rabinovich - Keysight Technologies
- ❑ Upen Kareti - Cisco systems

Ali Ghiasi's Suggested BGA Configuration

www.ieee802.org/3/df/public/22_10/22_0927/ghiasi_3df_01_220927.pdf

Hypothetical 512x200G Switch

□ Likely will require 90x90 BGA

- Provides $\sqrt{2}$ for FEXT pairs
- Provides 2 balls separations for NEXT
- For the hypothetical switch with 28x34 mm die results in 42 mm long substrate trace!

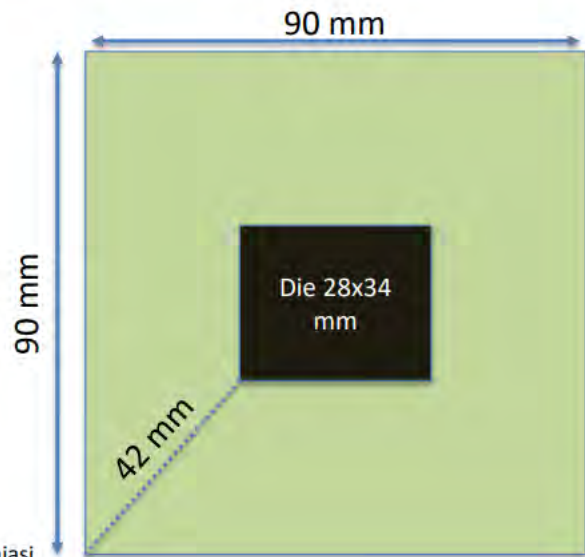

A. Ghiasi

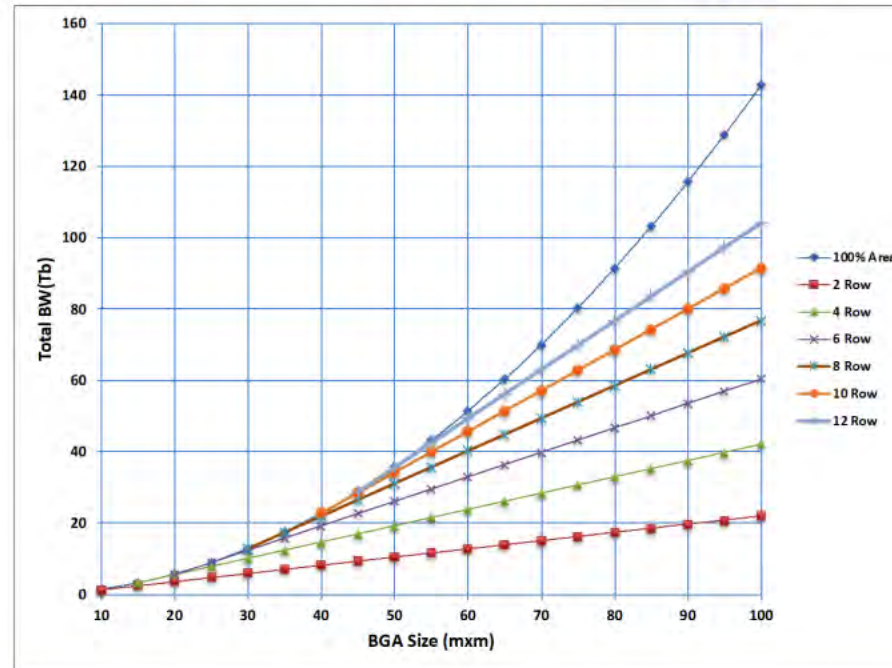
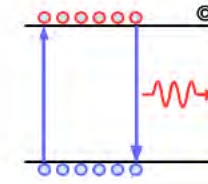

For the BGA ball grid assumed, see <https://opg.optica.org/oe/fulltext.cfm?uri=oe-23-3-2085&id=310831>

802.3df Task Force

10

Full Population of 512 Tx Lanes & 512 Rx Lanes

92X92 BALL-OUT MATRIX ACCORDING

- ❑ No overhead was taken for CMOS, PCIe, or any addition signals
- ❑ Routing of Tx, or Rx lanes can easily be 40-45mm long, or even longer in congestion cases

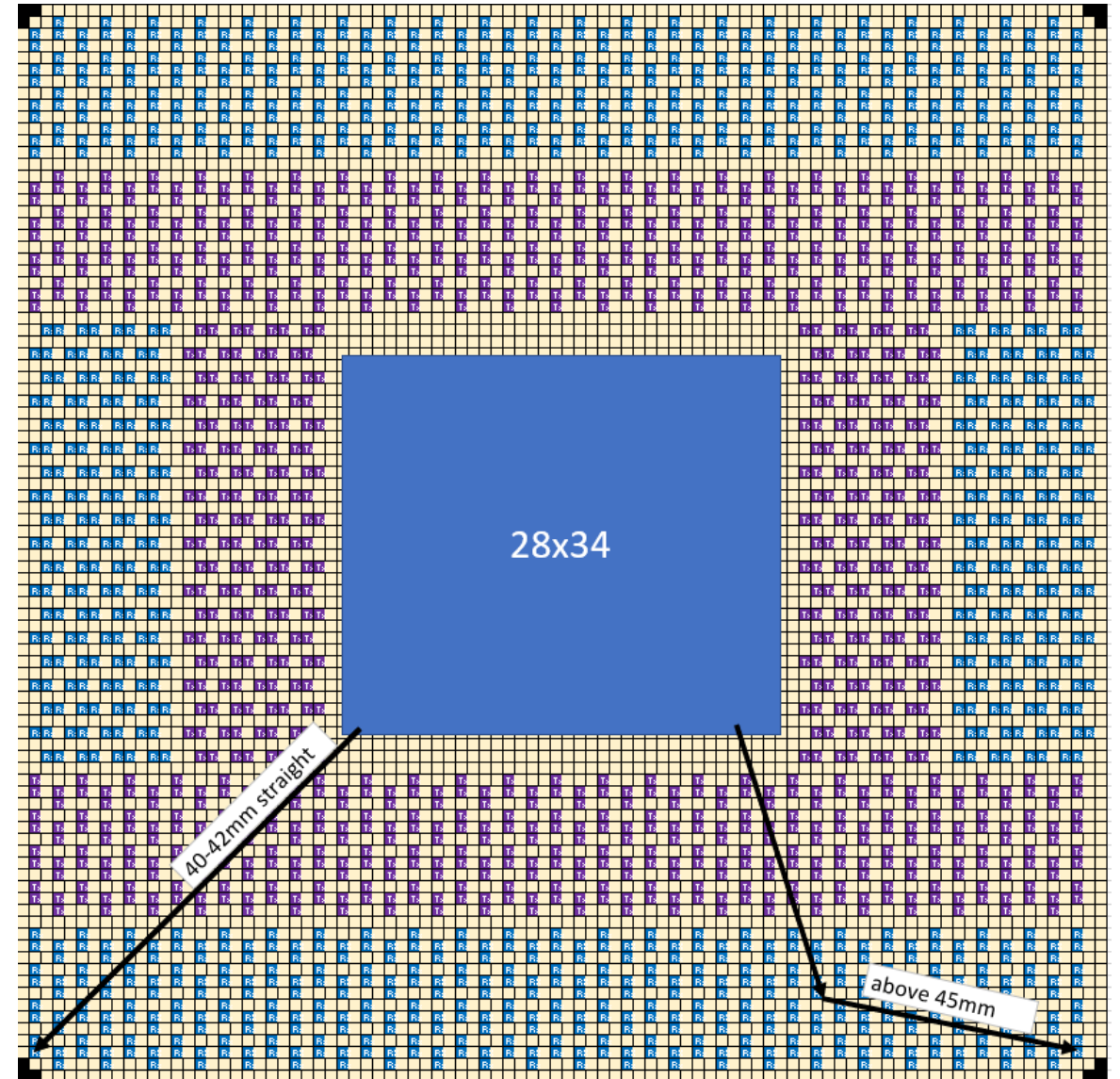

Expected Losses of Next Gen Material

- ghiasi_3df_01_220927: “benartsi_3df_01b_2207 uses best ABF conventional 27-45-27 μm construction and reports trace loss of 0.31 dB/mm @53 GHz (loss include transition via/BGA) • Benartsi loss expect to be lower ~ 0.22 dB/mm after accounting for improved surface roughness”

CK and Next Gen Package Losses for Reduced Trace Width

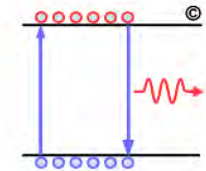

- Adjust trace width to 27 μm as suggested by [benartsi_3df_01b_2207](#)
 - Use the same Hurray surface roughness model that was previously matched best ABF film in 2018/2019
 - Reduced trace width may be required for some high radix switches implementations
 - Losses for 27 μm wide 92.5 Ω stripline traces
 - For best ABF film from 2018/2019 the CK 30 mm package trace loss is 3.94 dB or 0.13 dB/mm instead of assumed 0.109 dB/mm assumed loss @26.56 GHz
 - Next Gen 2022 ABF film the 30 mm package trace loss would be 5.6 dB or 0.19 dB/mm @53.1 GHz (6.75 dB or ~ 0.225 dB/mm 90°C).

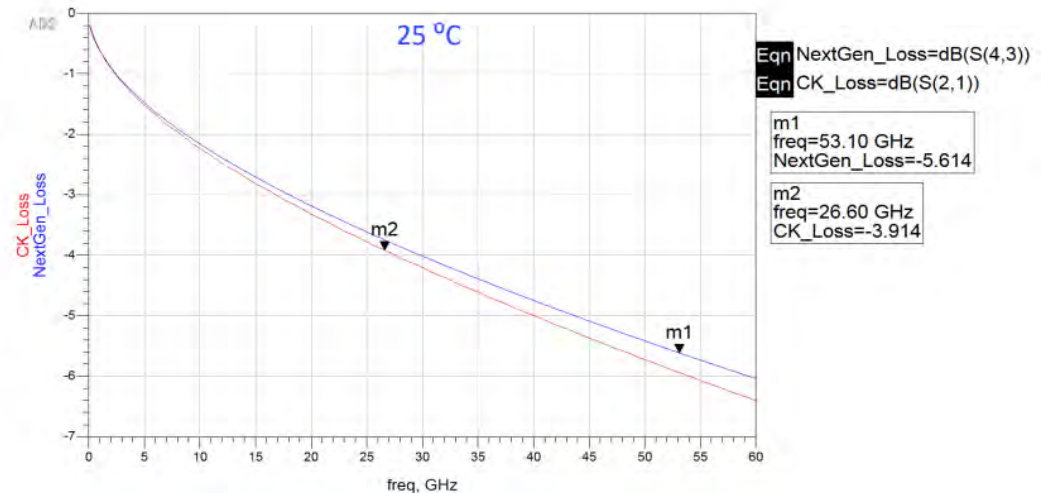

Loss Reported is only for the trace and does not include transition Via/BGA

Adjusted Extraction of Loss/mm

- ❑ 40 μ dielectric height ; 15 μ copper thickness ; 27 μ -45 μ -27 μ trace geometry
- ❑ The resulting loss/mm \approx 0.21dB
- ❑ Conductivity was updated to correlate and account for high temperature
- ❑ Correlates to the expected and measured loss/mm

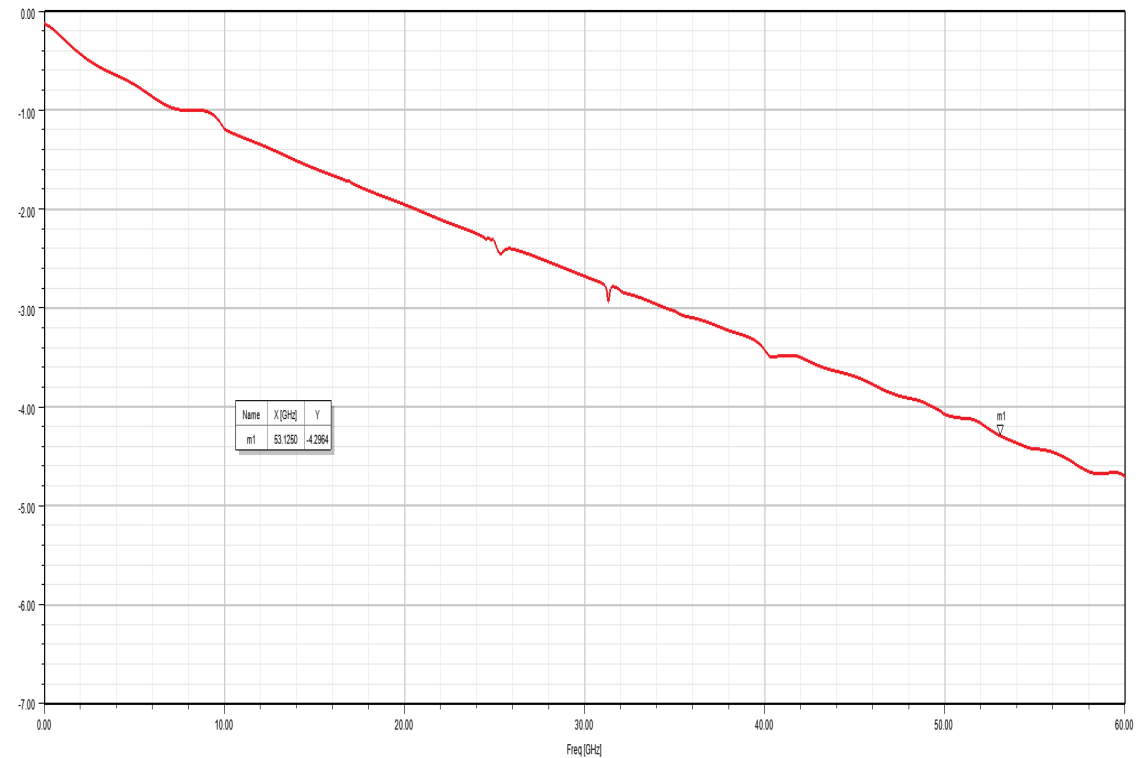
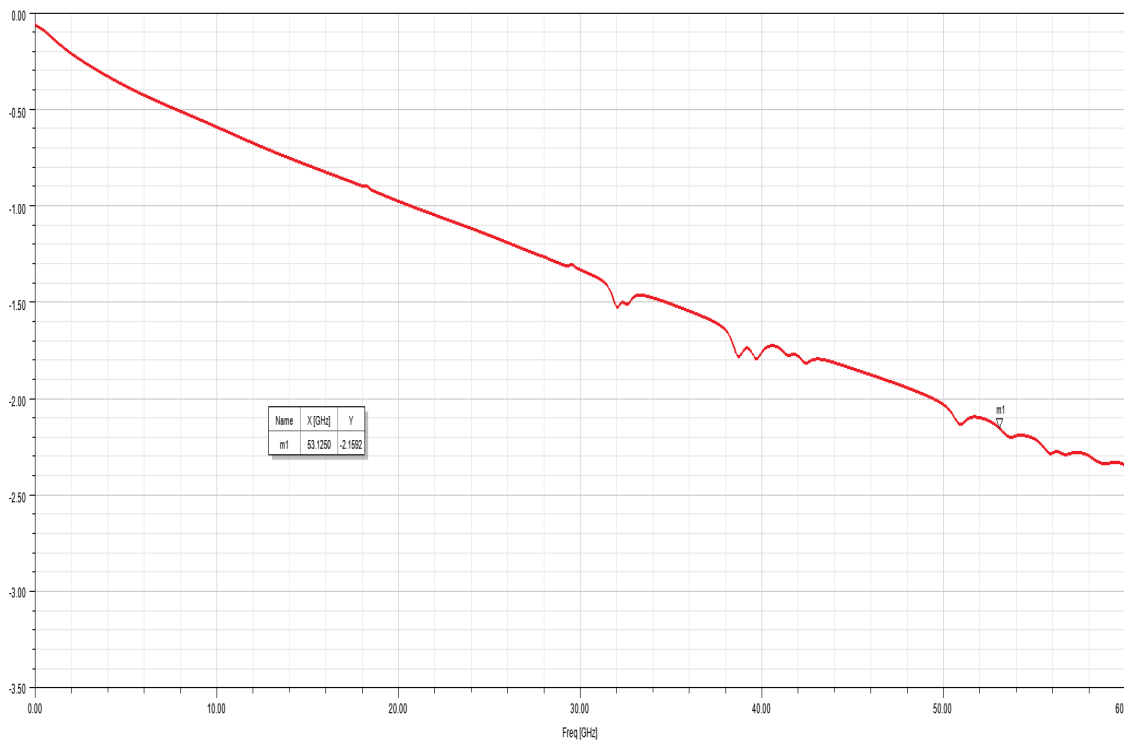

Iteratively adjust γ_0 , a_1 , a_2 , τ

COM MODEL: IEEE802.3 ANNEX 93A.1.2.3

□ Also tune

- Z_p , Z_c , C_b , C_p

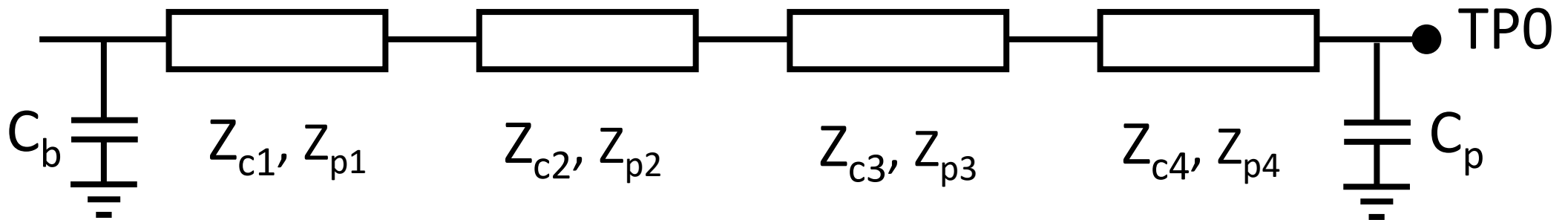

COM Model Results

COM MODEL: IEEE802.3 ANNEX 93A.1.2.3

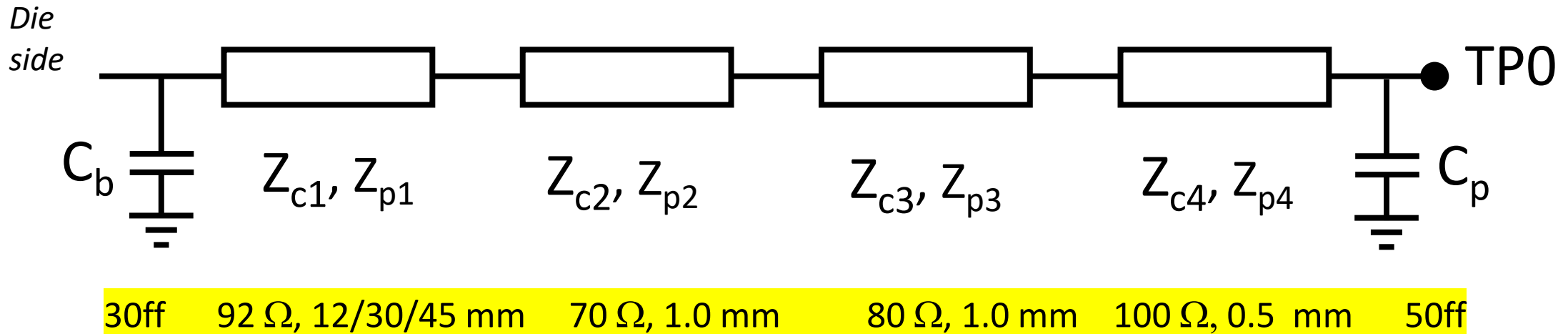

$$\gamma_0 = 0, a_1 = 0.0008455, a_2 = 0.000340225, \tau = 0.00644805$$

Graphic View of Results

45 MM PKG HAS ABOUT -10DB LOSS AT 53.125 GHZ

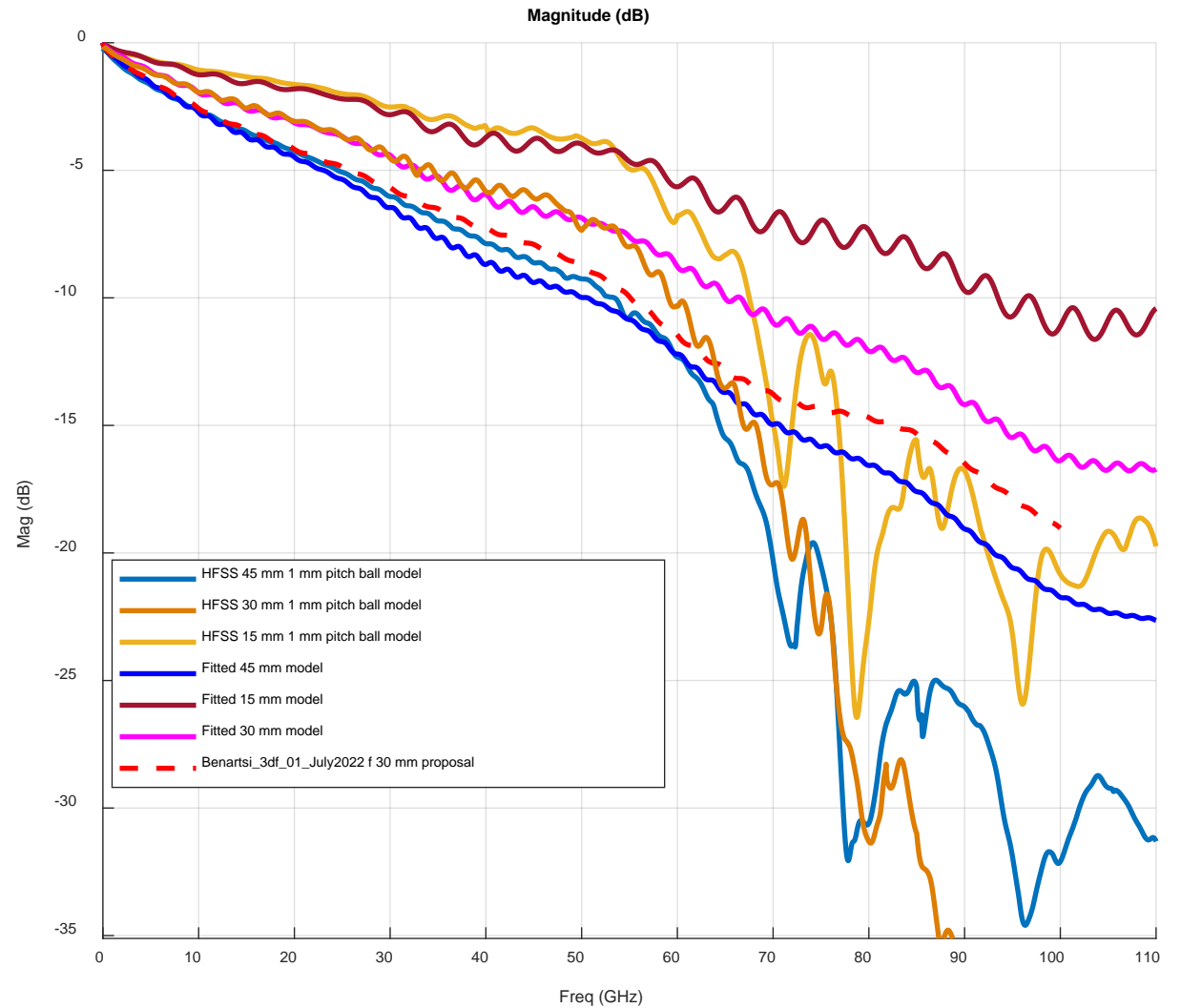
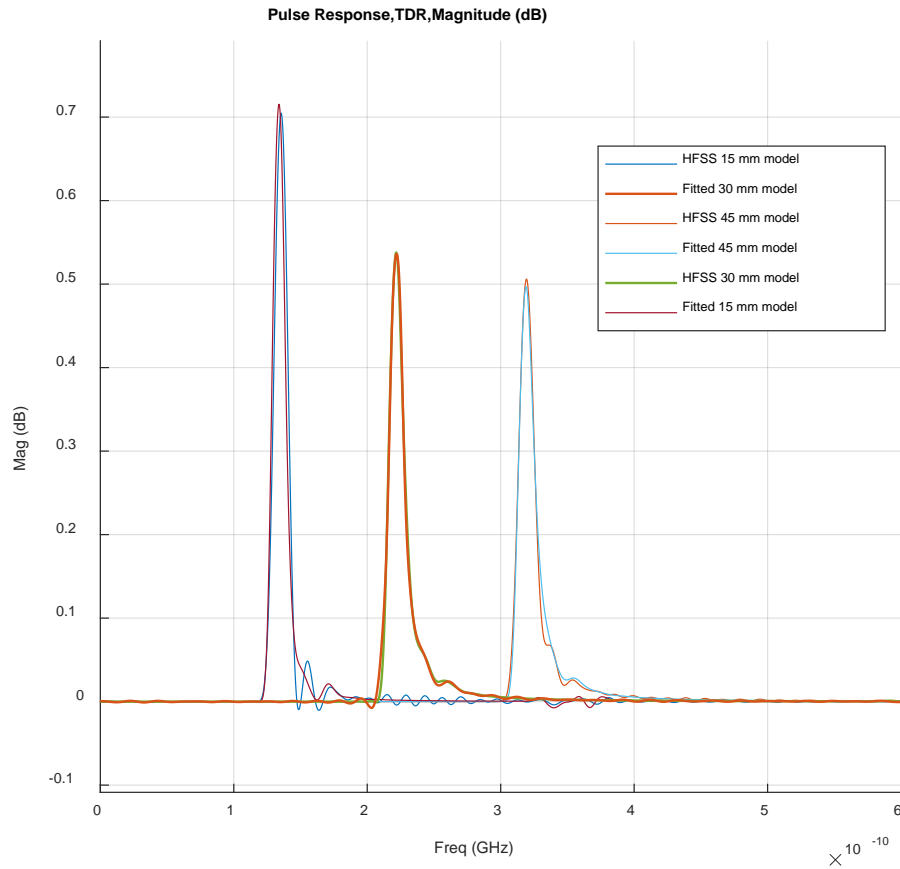

COM Config Settings

C2M EXAMPLE

Table 93A–3 parameters		
Parameter	Setting	Units
package_tl_gamma0_a1_a2	[0 0.0008455 0.000340225]	
package_tl_tau	0.00644805	ns/mm
package_Z_c	[92 92 ; 70 70; 80 80; 100 100]	Ohm

C_d	[0.4e-4 0.9e-4 1.1e-4 ;0 0 0]
L_s	[.12 .15 .14; 0 0 0]
C_b	[.3e-4 0]
z_p select	[1 2 3]
z_p (TX)	[12 30 45 ; 1 1 1 ; 1 1 1 ; 0.5 0.5 0.5]
z_p (NEXT)	[0 0 0; 0 0 0;0 0 0 ;0 0 0]
z_p (FEXT)	[12 30 45 ; 1 1 1 ; 0.1 0.1 0.1 ; 0.58 0.58 0.58]
z_p (RX)	[0 0 0; 0 0 0;0 0 0 ;0 0 0]
C_p	[0.5e-4 0]

Test Cases

	$z_p=15$	$z_p=30$	$z_p=45$
C2M_PCB_93ohms_10dB_202208016_v2_thru1.s4p	concat_pkg_15mm_pcb_10dB	concat_pkg_30mm_pcb_10dB	concat_pkg_45mm_pcb_10dB
C2M_PCB_93ohms_26dB_202208016_v2_thru1.s4p	concat_pkg_15mm_pcb_26dB	concat_pkg_30mm_pcb_26dB	concat_pkg_45mm_pcb_26dB

Channels are from [akinwale 3df elec 01 220921](#)

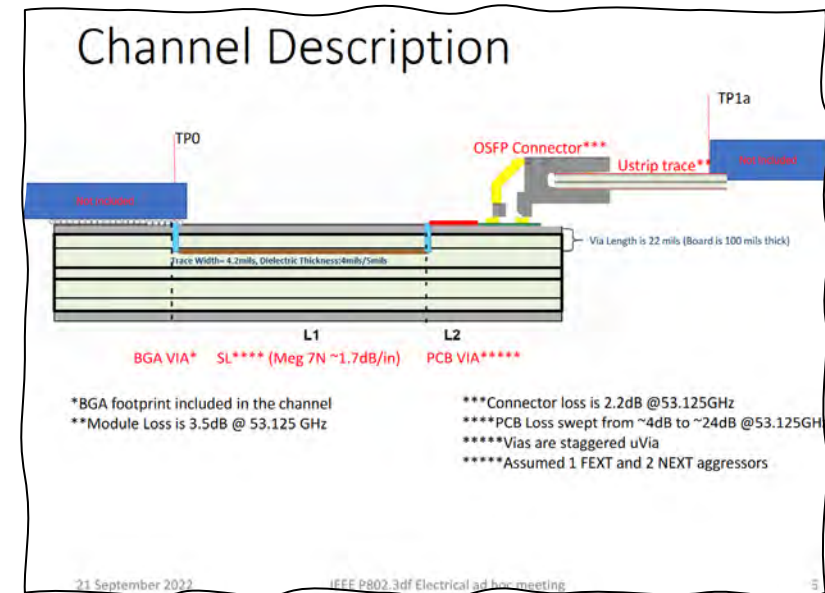

S-parameter Concatenation (HFSS model)

Example case: 15 mm + 10 dB

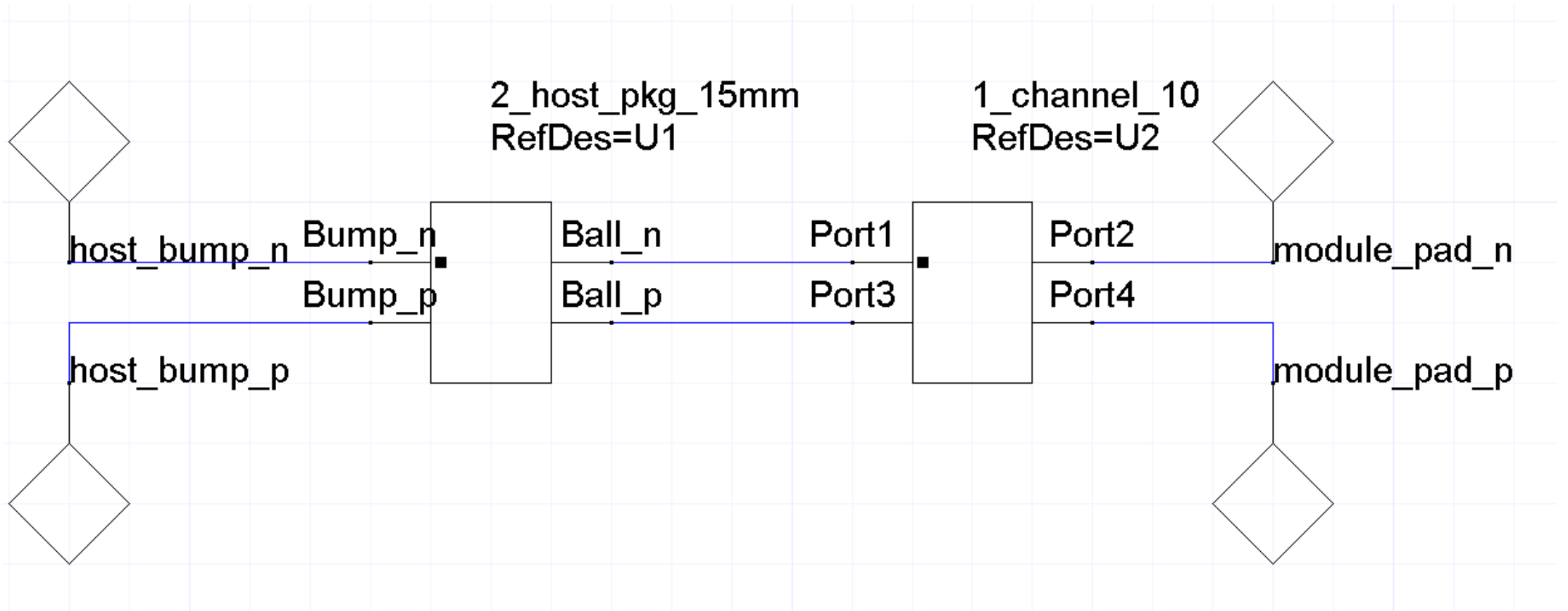

TDR Verification of the Concatenation

Example case: 15 mm + 10 dB

Good match on both sides

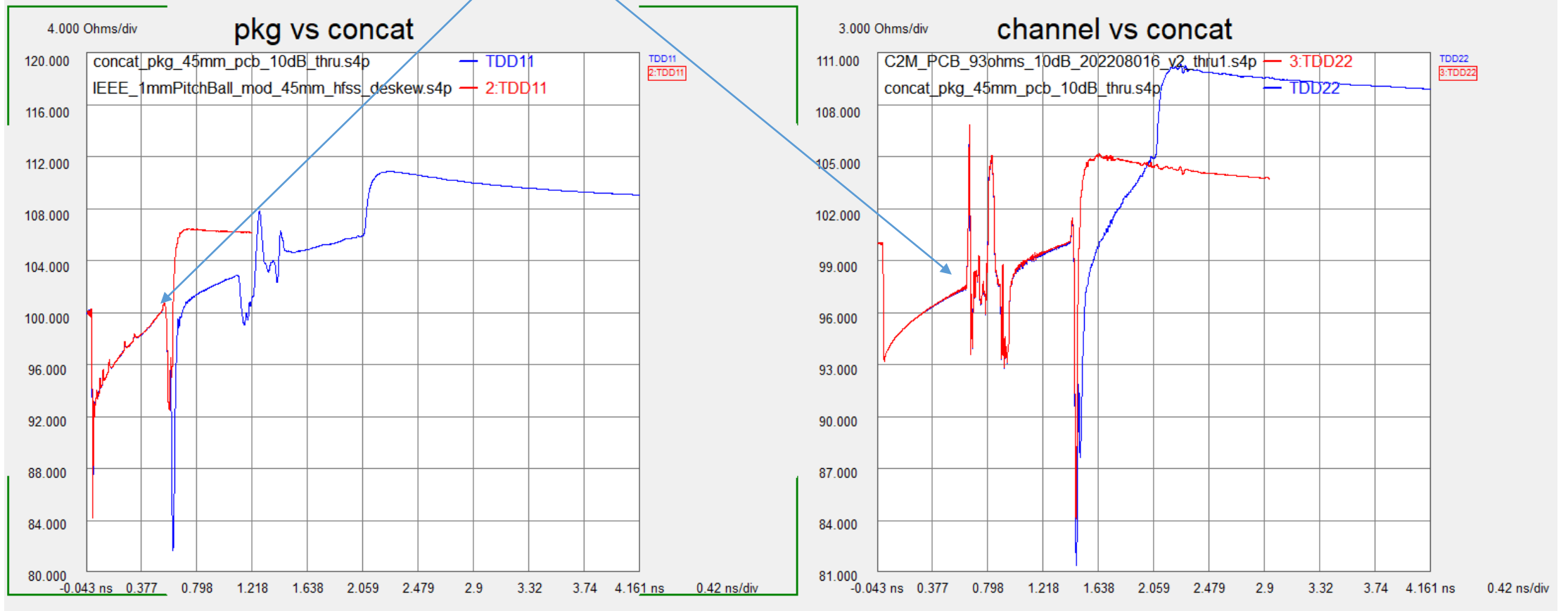

COM model parameters (pkg model added only at Tx/TP0 side)

Parameter	Setting	Units	Information
f_b	106.25	GBd	
f_min	0.02	GHz	
Delta_f	0.02	GHz	
C_d	[40 90 110; 40 90 110]*1e-6	nF	[TX RX]
L_s	[0.13 0.15 0.14; 0.13 0.15 0.14]	nH	[TX RX]
C_b	[30e-6 30e-6]	nF	[TX RX]
z_p select	1		[test cases to run]
z_p (TX)	[15 30 45; 1 1 1; 1 1 1; 0.5 0.5 0.5]	mm	[test cases]
z_p (NEXT)	[0 0 0; 0 0 0; 0 0 0]	mm	[test cases]
z_p (FEXT)	[15 30 45; 1 1 1; 1 1 1; 0.5 0.5 0.5]	mm	[test cases]
z_p (RX)	[0 0 0; 0 0 0; 0 0 0]	mm	[test cases]
C_p	[50e-6 0]	nF	[TX RX]
R_0	50	Ohm	
R_d	[50 50]	Ohm	[TX RX]
A_v	0.413	V	
A_fe	0.413	V	
A_ne	0.608	V	
L	4		
M	32	Samp/UI	
samples_for_C2M	100	Samp/UI	
T_0	50	mUI	
AC_CM_RMS	0	V	[test cases]
filter and Eq			
f_r	0.55	*fb	
c(0)	0.5		min
c(-1)	[-0.34:0.02:0]		[min:step:max]
c(-2)	[0:0.02:0.14]		[min:step:max]
c(-3)	[-0.06:0.02:0]		[min:step:max]
c(-4)	[0:0.01:0.03]		[min:step:max]
c(1)	[-0.1:0.02:0]		[min:step:max]
N_b	24	UI	
b_max(1)	1		As/dffe1
b_max(2..N_b)	0.3		As/dfe2..N_b
b_min(1)	0.3		As/dffe1
b_min(2..N_b)	-0.15		As/dfe2..N_b
g_DC	[-18:1:-8]	dB	[min:step:max]
f_z	42.5	GHz	
f_p1	42.5	GHz	
f_p2	106.25	GHz	
g_DC_HP	[-3:0.5:0]		[min:step:max]
f_HP_PZ	0.6	GHz	

I/O control		
DIAGNOSTICS	1	logical
DISPLAY_WINDOW	0	logical
CSV_REPORT	1	logical
RESULT_DIR	[results\200GEL_C2M host (date)\]	Path
SAVE_FIGURES	0	logical
Port Order	[1 3 2 4]	
RUNTAG	C2M_eval_	
COM_CONTRIBUTION	0	logical
Local Search	2	
Operational		
COM Pass threshold	3	dB
ERL Pass threshold	7.3	dB
DER_0	1.00E-04	
T_r	6.00E-03	ns
FORCE_TR	1	5
PMD_type	C2C	
BREAD_CRUMBS	0	logical
SAVE_CONFIG2MAT	1	logical
PLOT_CM	0	logical
TDR and ERL options		
TDR	1	logical
ERL	1	logical
ERL_ONLY	0	logical
TR_TDR	0.01	ns
N	1200	
beta_x	0	
rho_x	0.618	
fixture delay time	[0 0]	[port1 port2]
TDR_W_TXPKG	0	
N_bx	0	UI
Tukey_Window	1	
Receiver testing		
RX_CALIBRATION	0	logical
Sigma BBN step	5.00E-03	V
Noise_jitter		
sigma_RJ	0.01	UI
A_DD	0.02	UI
eta_0	4.00E-09	V^2/GHz
SNR_TX	32.5	dB
R_LM	0.95	

Table 93A-3 parameters	Parameter	Setting	Units
	package_tl_gamma0_a1_a2	[0 8.455e-4 3.40225e-4]	
	package_tl_tau	6.448E-03	ns/mm
	package_Z_c	[92 92; 70 70; 80 80; 100 100]	Ohm
ICN & FOM_ILD parameters			
	f_v	0.371	*Fb
	f_f	0.371	GHz f_r specified in first column
	f_n	0.371	GHz
	f_2	58.4375	GHz
	A_ft	0.600	V
	A_nt	0.600	V

Histogram_Window_Weight	sigma_r	
Gaussian	0.02	gaussian, triangle, rectangle
		sigma in UI fo or gauss.. Wind

Table 92-12 parameters	Parameter	Setting	Units
	board_tl_gamma0_a1_a2	[0 3.8206e-04 9.5909e-05]	
	board_tl_tau	0.00579	ns/mm
	board_Z_c	100	Ohm
	z_bp (TX)	407	mm
	z_bp (NEXT)	407	mm
	z_bp (FEXT)	407	mm
	z_bp (RX)	407	mm
	C_0	0	nF
	C_1	0	nF
	Include PCB	0	logical

Floating Tap Control		
N_bg	3	0 1 2 or 3 groups
N_bf	3	taps per group
N_f	80	UI span for floating taps
bmaxg	0.2	max DFE value for floating taps
N_tail_start	24	
B_float_RSS_MAX	0.1	

different for each test fixture

updated for 802.3df/dj C2M

Frequency Domain Comparison

(After concatenation, how well does the “model” channel match “HFSS” channel?)

Example case: 15 mm + 10 dB

ILDD

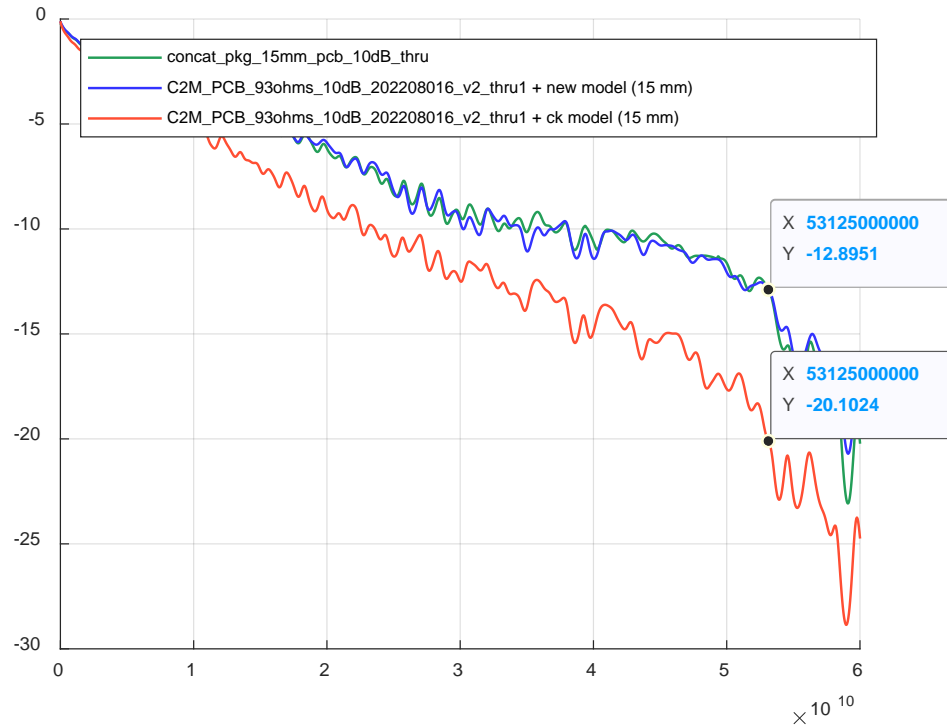

RLDD

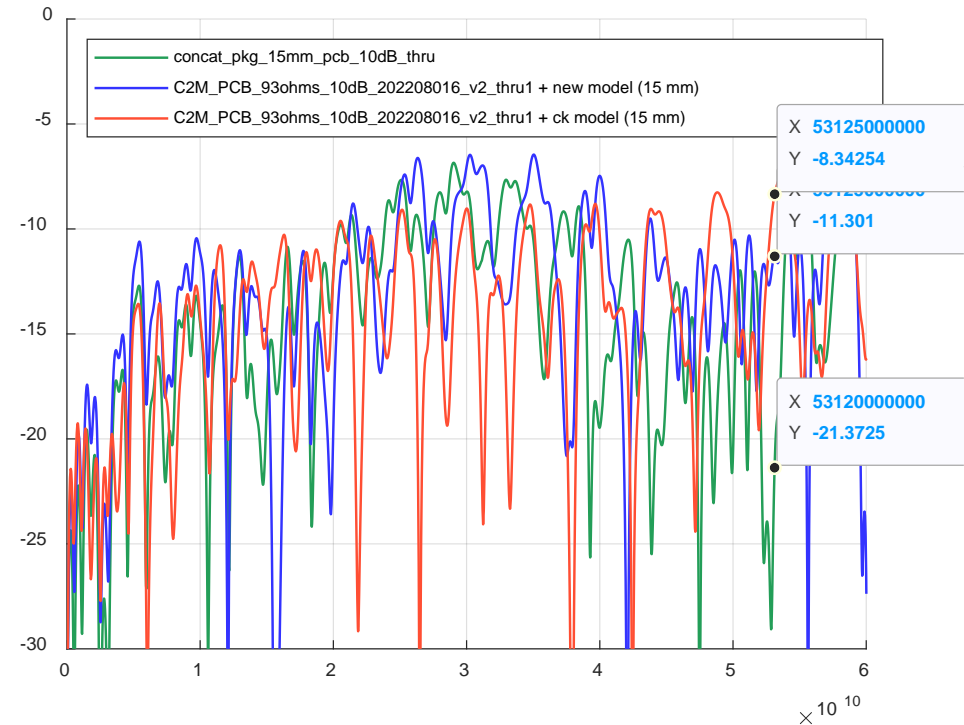

Time domain SBR comparison

Example case: 15 mm + 10 dB

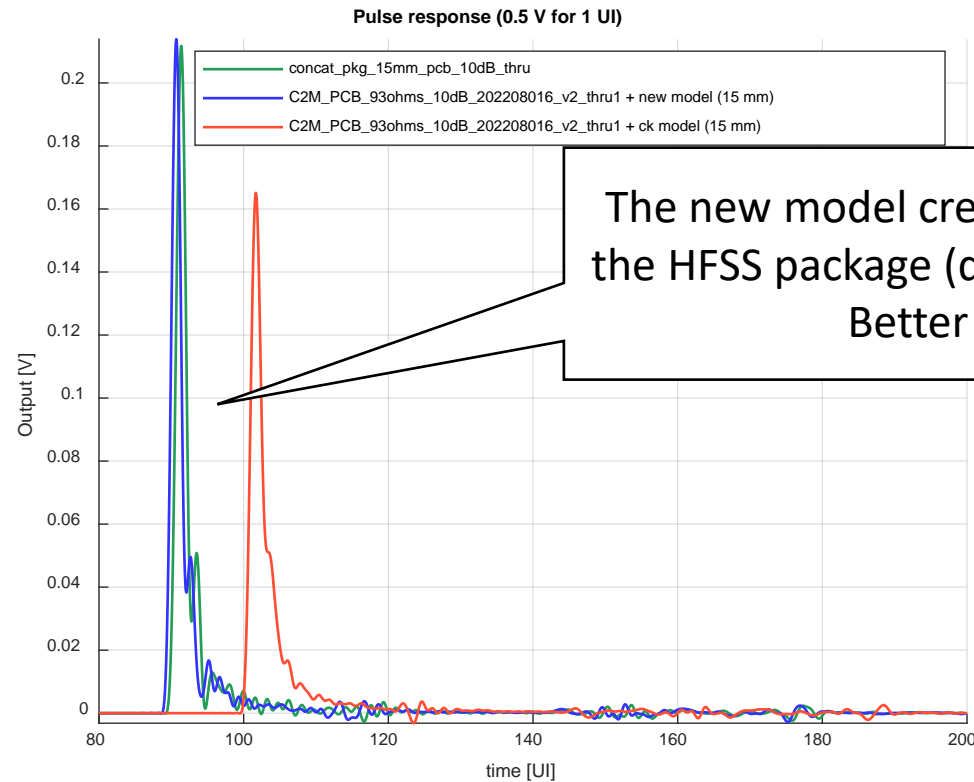

The new model creates a response that is close to the HFSS package (delay, pulse shape, pulse height) Better than the ck model

COM Results Comparison

COM_dB per channel_id, host_pkg_trace_len, Pkg model

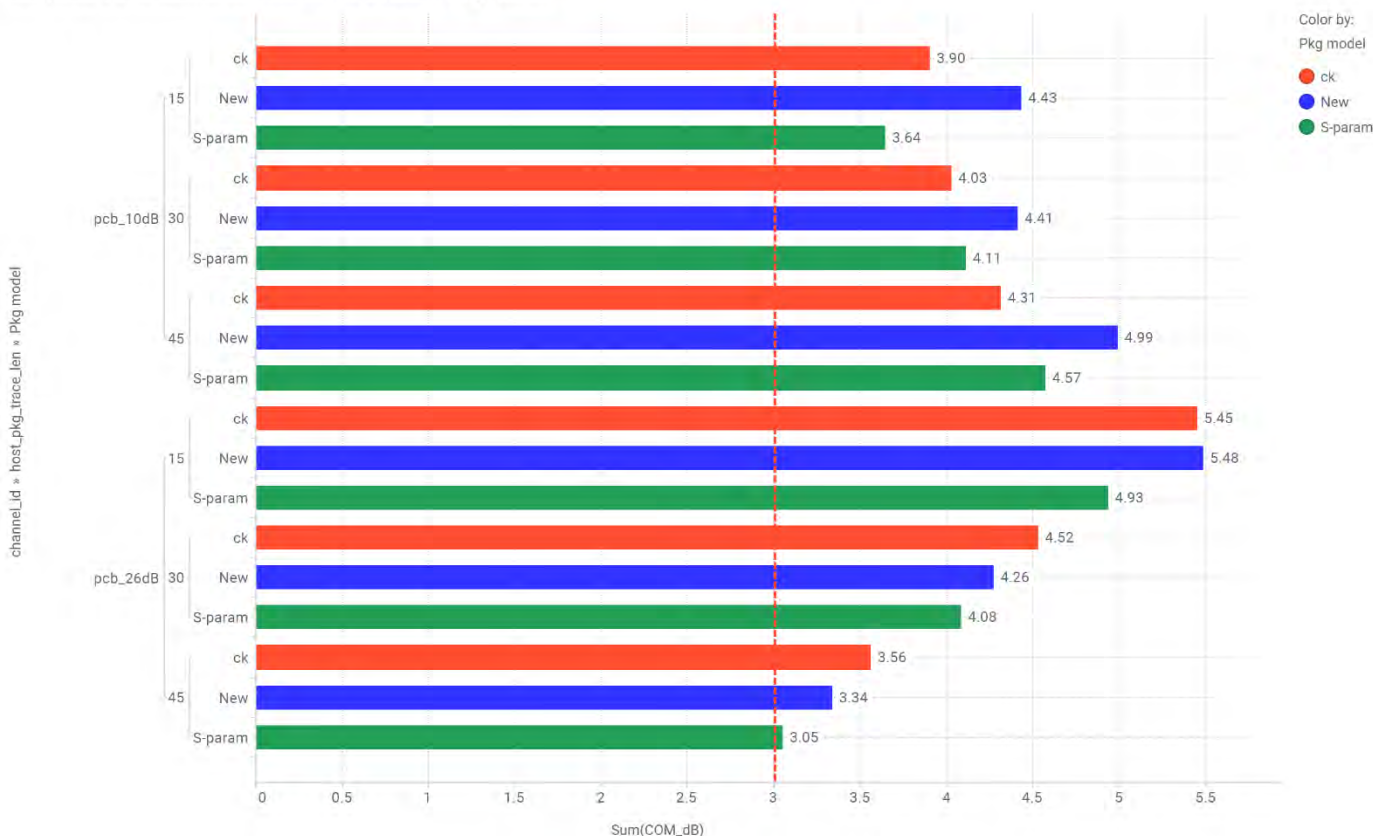

- ❑ COM results with the updated fitted model (**blue**) are consistently higher than with HFSS S-parameter concatenation (**green**)
 - ❑ The difference is usually 0.2-0.5 dB
 - ❑ The “shortest” combination is an exception
- ❑ For the high loss channel, the new model is closer to the HFSS results than the ck model (**red**)
 - ❑ For the low loss channel, the ck model had worse COM in 2 cases!
- ❑ The fitted model is somewhat optimistic...?
 - ❑ but in a more consistent way than the old model

Conclusions & Recommendations

- ❑ An updated correlated COM package model was supplied
 - Accounts for:
 - High radix switch package routing layers
 - ~90°C package operating temperature
 - A Realistic trace width
- ❑ A possible ball-out was shown to occupy 92x92 ball matrix
 - Recommend to have at least one COM PKG length setting at ~45mm
 - Other 1/2 settings to be 12 (for backward compatibility) & 30
- ❑ Initial COM runs with the updated fitted model were shown to have ~0.3dB better COM result compared to HFSS concatenated models
- ❑ Recommend using fitted model with 12;30;45mm while keeping COM result discrepancy in mind

Thank You!