

Coupling Attenuation & Burst test on balanced cables and cabling systems

Ralf Tillmanns/ Weidmüller Interface GmbH & Co. KG

02/07/2024

Agenda

- Coupling Attenuation, CA & LFCA, Principle
- Test Results of different SPE-Cables
- Test results of SPE Connectors and Assemblies, 3m length
- LFCA/CA of unscreened SPE Cables
- Burst test
- MICE table
- Coupling attenuation of different SPE cables
- Conclusion & Outlook

Coupling Attenuation, CA & LFCA, Principle

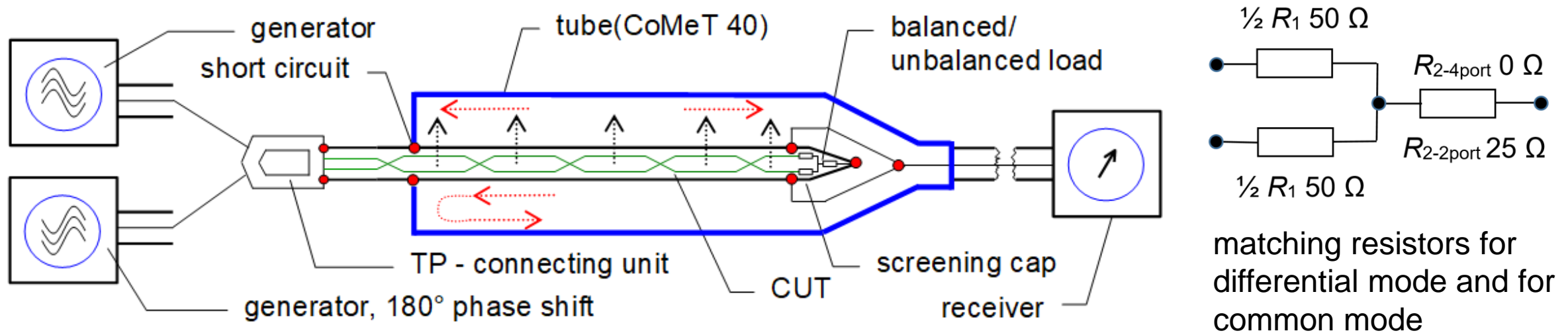

The balanced pair is fed with a 100 Ohm signal by two 50 Ohm generators with 180° phase shift ([virtual balun](#)). Energy couples from the “differential mode” into the “common mode” ([mode conversion](#)) and then from the “common mode” into the measuring tube (the outer circuit).

The short circuit at the near end causes a total reflection and the complete energy which coupled into the outer circuit is travelling to the receiver.

According to IEC 62153-4-9, [Coupling attenuation](#) can be measured only from 30 MHz upwards.

With the extension of IEC 62153-4-9 [Amd1](#) the **Low Frequency Coupling Attenuation**, [LFCA](#) can be measured now from 100 kHz upwards. – Proposed test length is 3 meter.

Coupling Attenuation, CA & LFCA, Principle

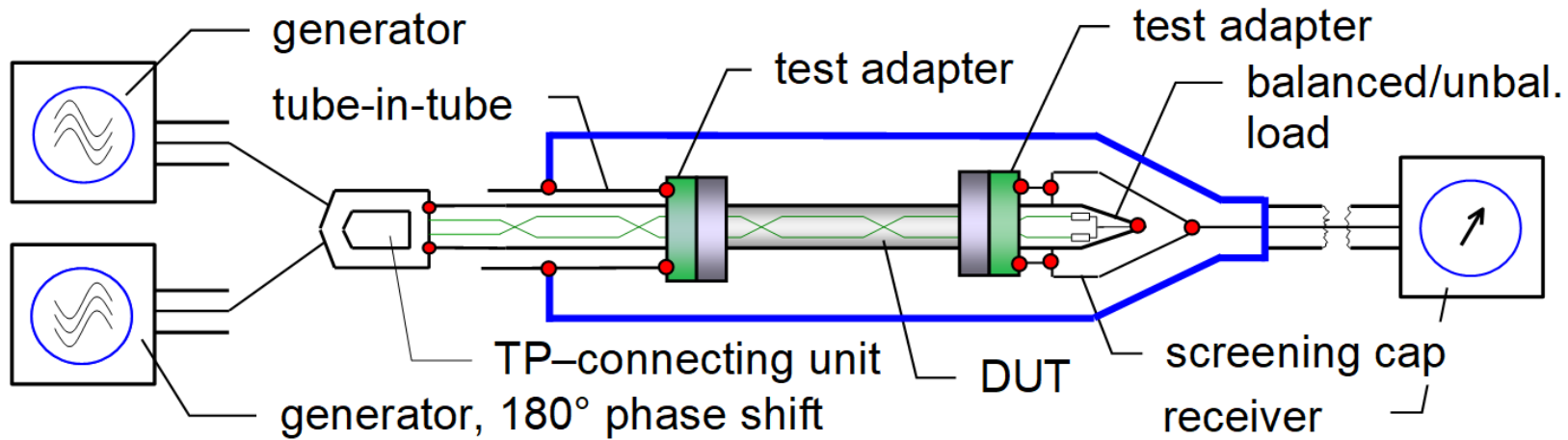

Test set-up for SPE assemblies with **tube-in-tube** procedure

The device under test (DUT) is placed between the two test adapter

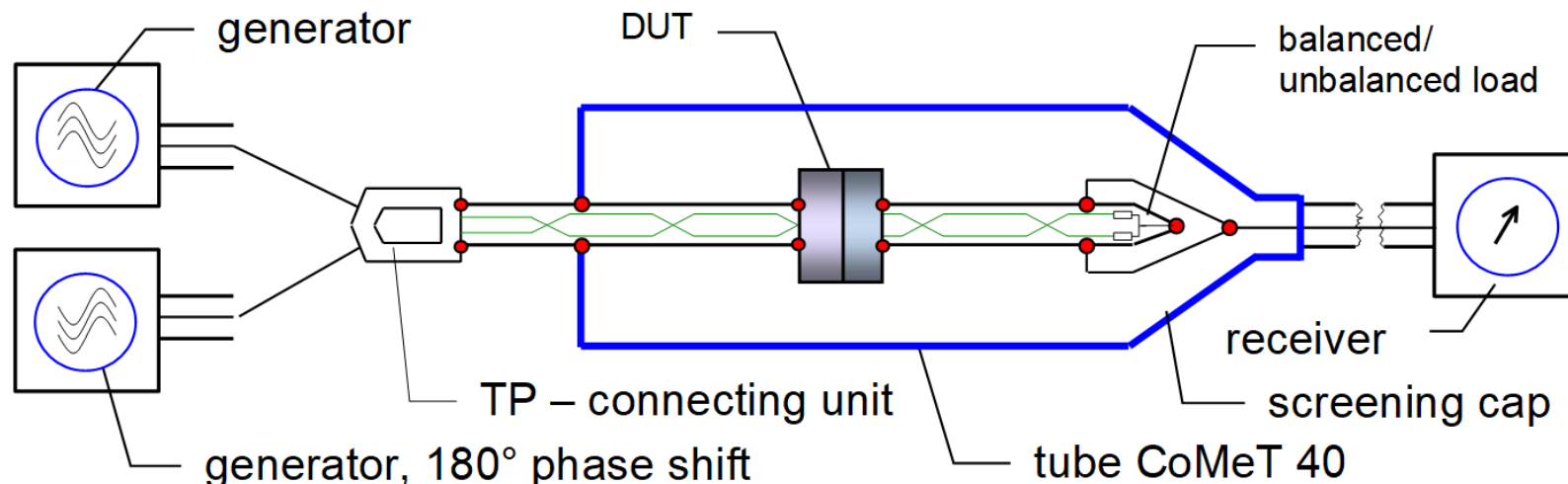

If the assembly is longer than the measuring tube, the assembly can be split in the middle and then coupled together

Test Results of different SPE-Cables

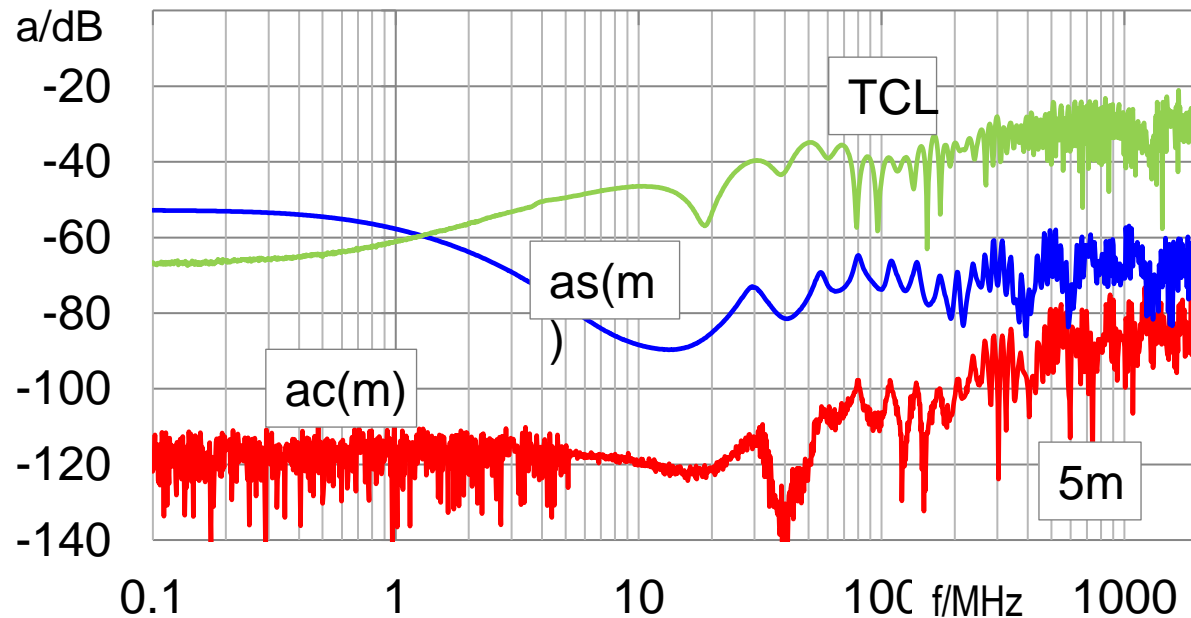

as(m) = measured screening attenuation
 ac(m) = measured coupling attenuation
 each **without corection and without normalization.**
 TCL = unbalance attenuation at near end, Scd11

Unbalance attenuation, screening attenuation & coupling attenuation of two different SPE cables with foil and braid as outer screen.

Coupling attenuation is the result of the interaction of unbalance attenuation (TCL) of the pair and the screening attenuation of the screen.

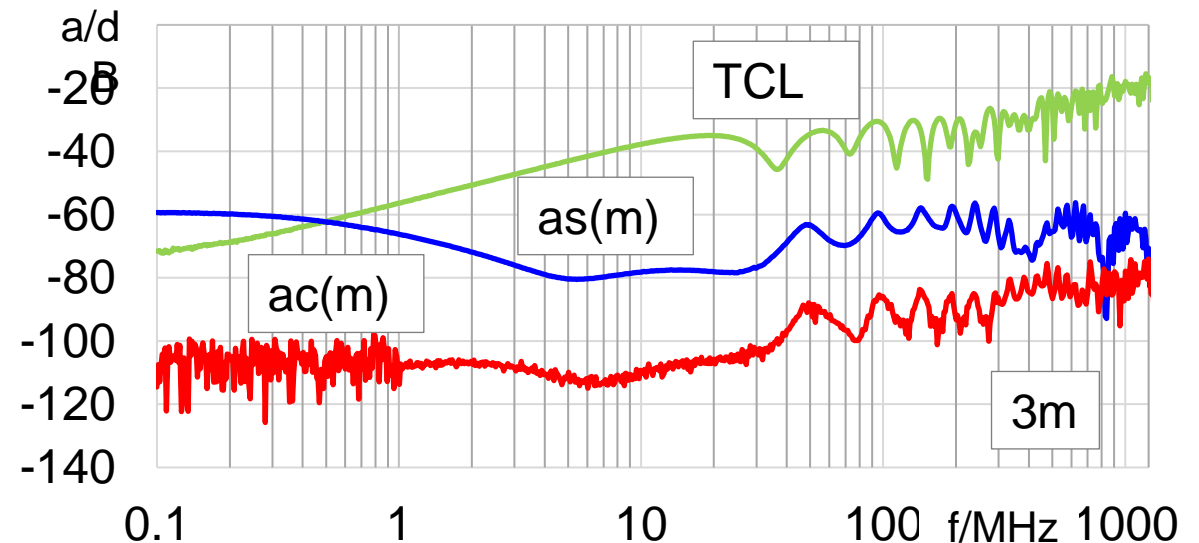

Test results of SPE Connectors and Assemblies, 3m length

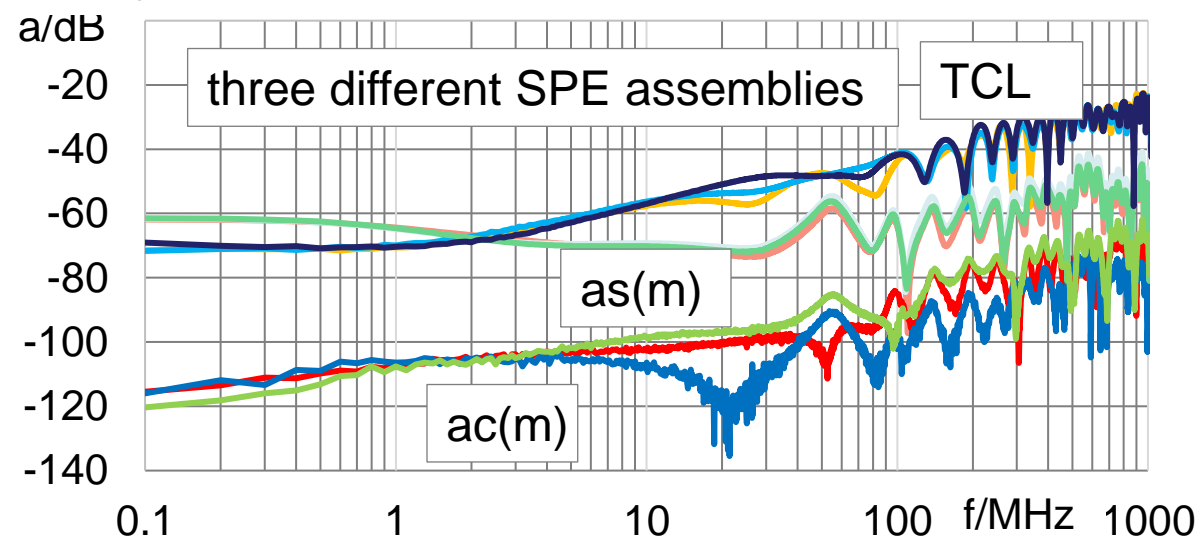
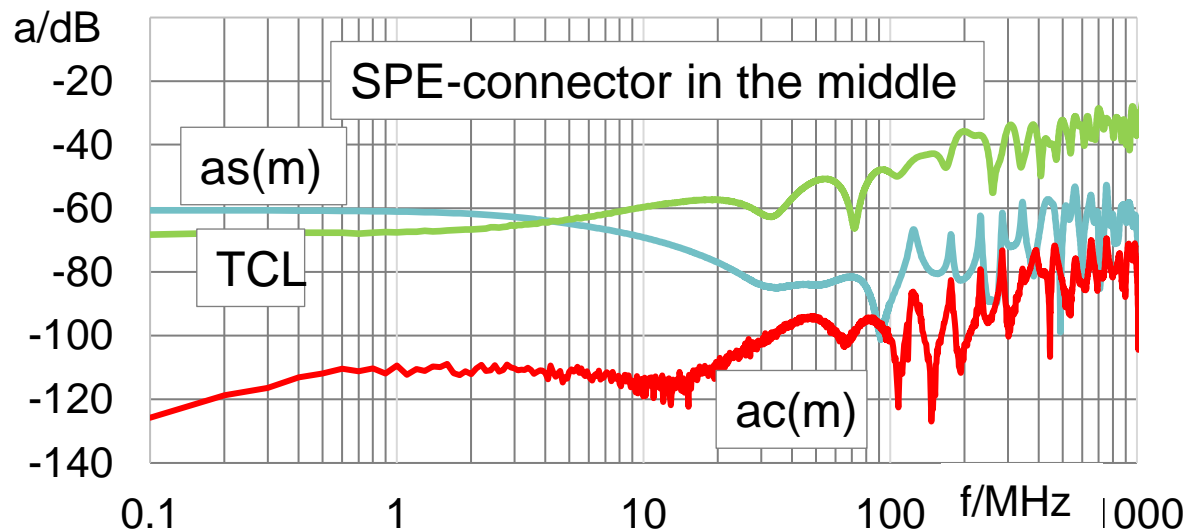
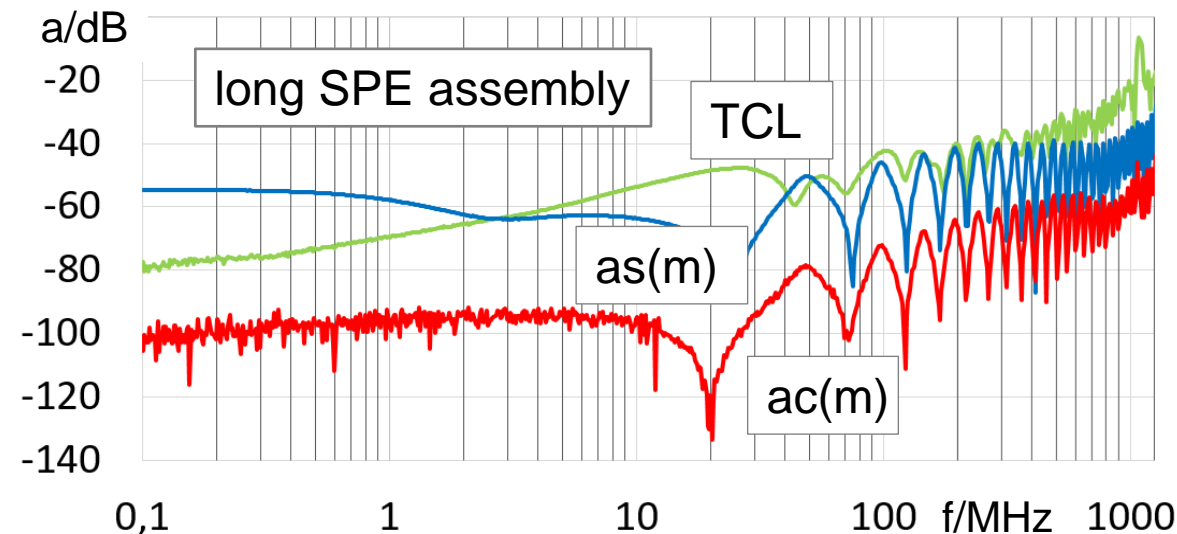
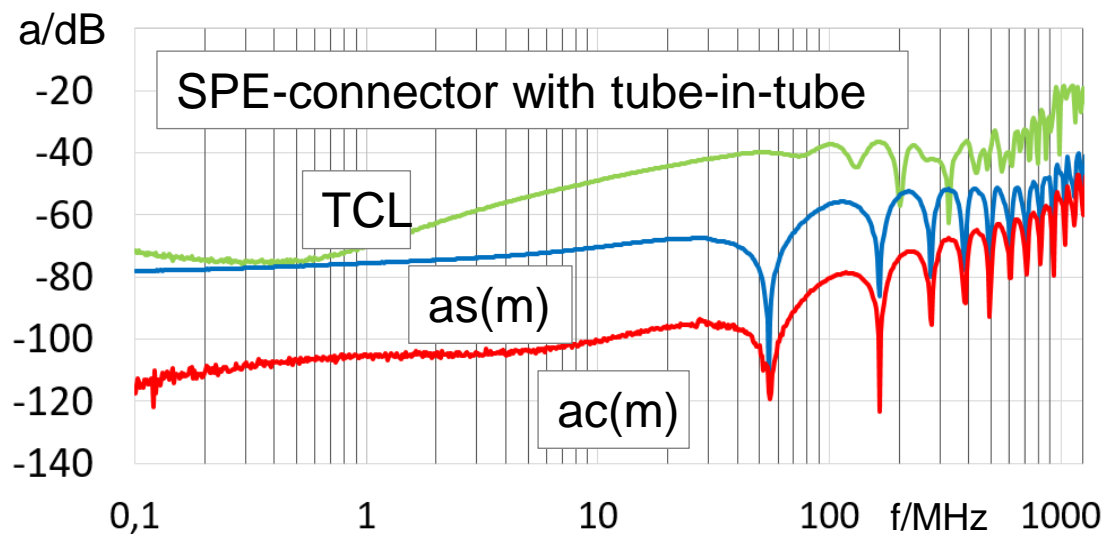

LFCA/CA of unshielded SPE Cables

Coupling attenuation **CA** & Low Frequency Coupling Attenuation **LFCA** of an unshielded balanced pair, IEC 62153-4-9Amd1

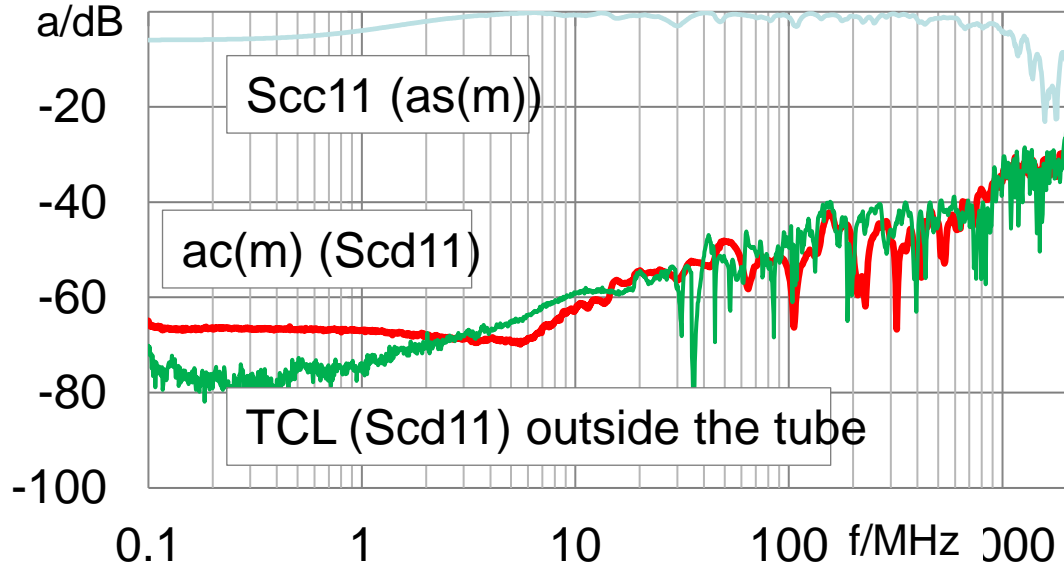
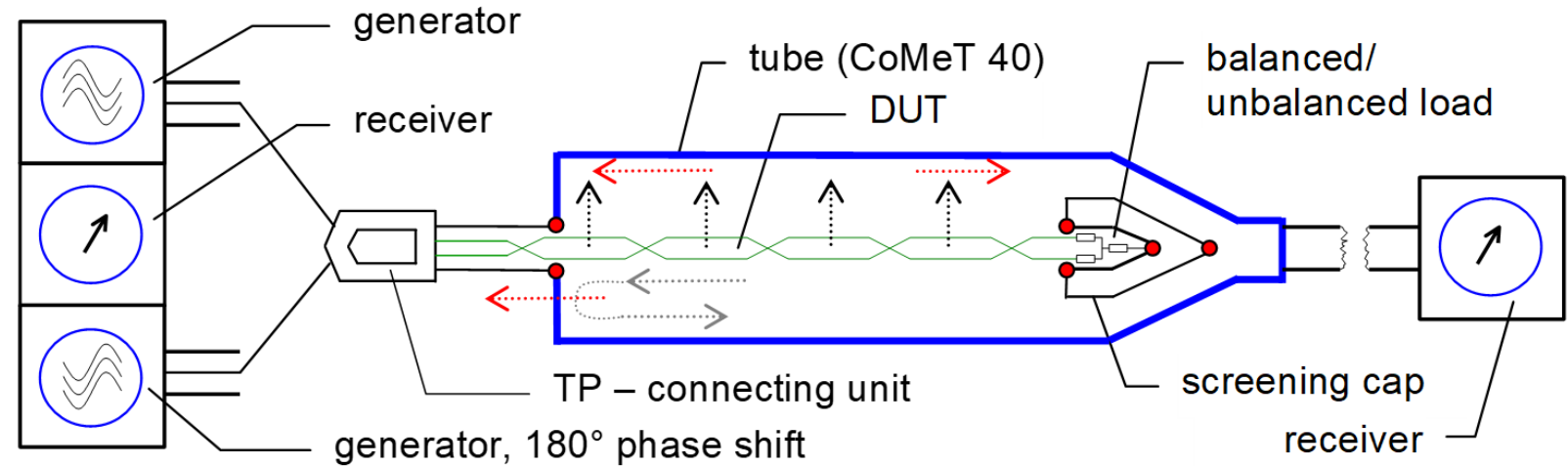

Because there is no shield in the unshielded pair, there is no near-end short circuit and no reflection. The near end wave runs back to the analyzer and can be measured there as Scd11. Therefore, coupling attenuation measurements of unshielded single pairs and connectors can be performed at both ends. The coupling attenuation at the near end is Scd11, which corresponds to the near end unbalance attenuation or the TCL of the test object

Burst test

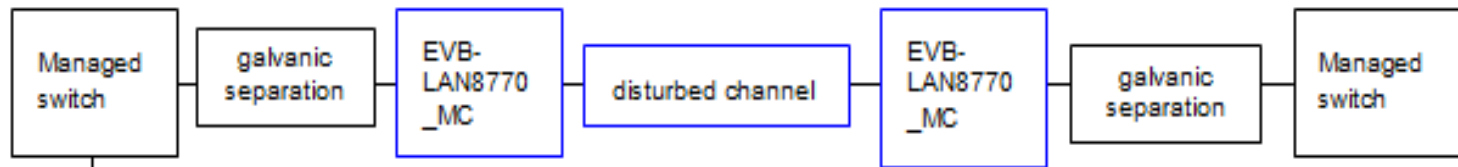

Cabling system for burst test

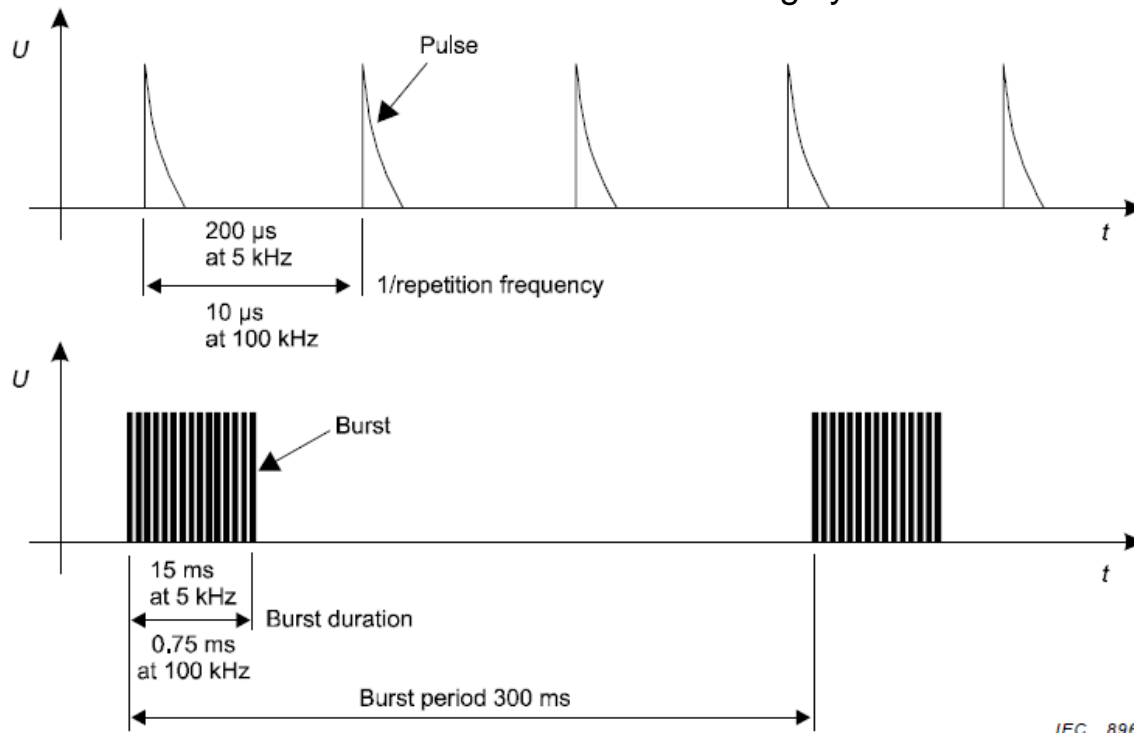

Representation of an electrical fast transient/burst, source: IEC 6100-4-4

Alternatively to the measurement of **coupling attenuation**, the interference immunity of SPE cables, connectors and components can be measured using the **burst test** according to IEC 61000-4-4 and evaluated according to IEC 61000-6-2.

The repetitive **fast transient test** according to IEC 61000-4-4 is a test with bursts consisting of a number of **fast transients**, coupled into power, control, signal and earth ports of the DUT

The shape of the burst signal is generated using a **burst generator** and **capacitively coupled** into the cabling system with a coupling clamp. At the same time, data packets are transmitted via the cabling system.

MICE table

	1	2	3
Mechanical rating	M ₁	M ₂	M ₃
Ingress rating	I ₁	I ₂	I ₃
Climatic rating	C ₁	C ₂	C ₃
Electromagnetic rating	E ₁	E ₂	E ₃

The [MICE table](#) according to ISO/IEC 11801-1 classifies the environment for generic cabling.

The letters in MICE each represent one type of Environmental impact :

- Mechanical,
- Ingress,
- Climatic/Chemical and
- [Electromagnetic impact](#)

Channel environments may be classified by using any combination of the MICE scheme, e.g. M₁I₂C₃E₁.

Table 2 – MICE requirements for burst test

Electromagnetic rating	E1	E2	E3
EFT/B (comms)	500V	500V	1000
	IEC 61000-6-1		IEC 61000-6-2

For each of these environmental impacts, there are three classes – 1, 2, and 3 – that represent [levels of severity](#).

Class 1 stands for lower impact as for office applications, class 2 for light industry and class 3 for heavy industry environments.

In this presentation, the [electromagnetic rating](#) respectively the MICE requirements for burst test are of interest.

Coupling attenuation of different SPE cables

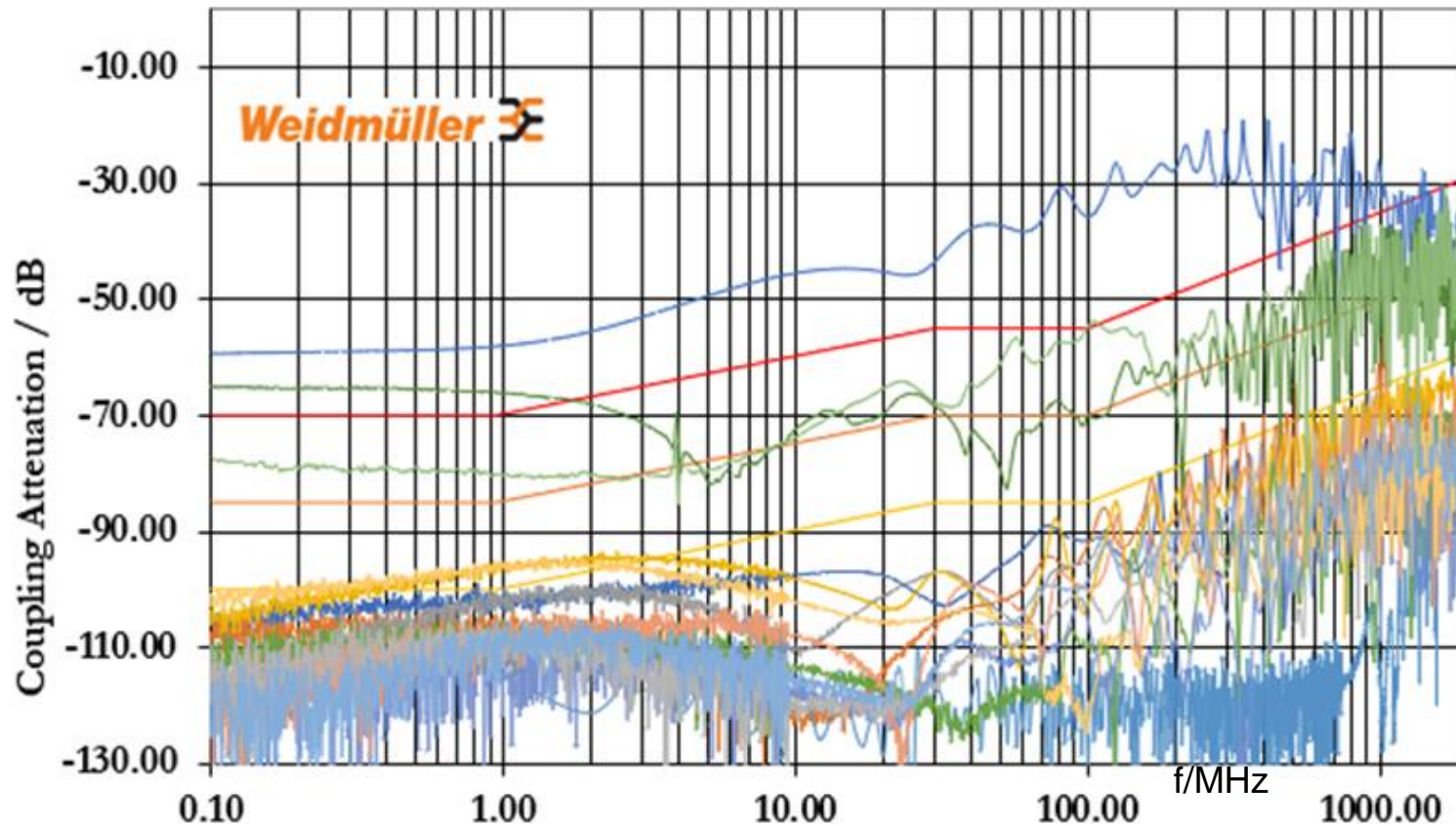

Coupling attenuation of different SPE cables with different screen constructions measured acc. to IEC 62153-4-9

Cables with foil/braid constructions and good unbalance attenuation fulfills Coupling attenuation Type I requirements,

Cables with foil only or with poor unbalance attenuation are in the range of Coupling attenuation Type Ib

Unscreened single pairs did not fulfill Coupling attenuation Type II requirements

----- Coupling attenuation Type I ----- Coupling attenuation Type Ib
----- Coupling attenuation Type II (IEC 61156)

Correlation between Coupling attenuation and Burst test

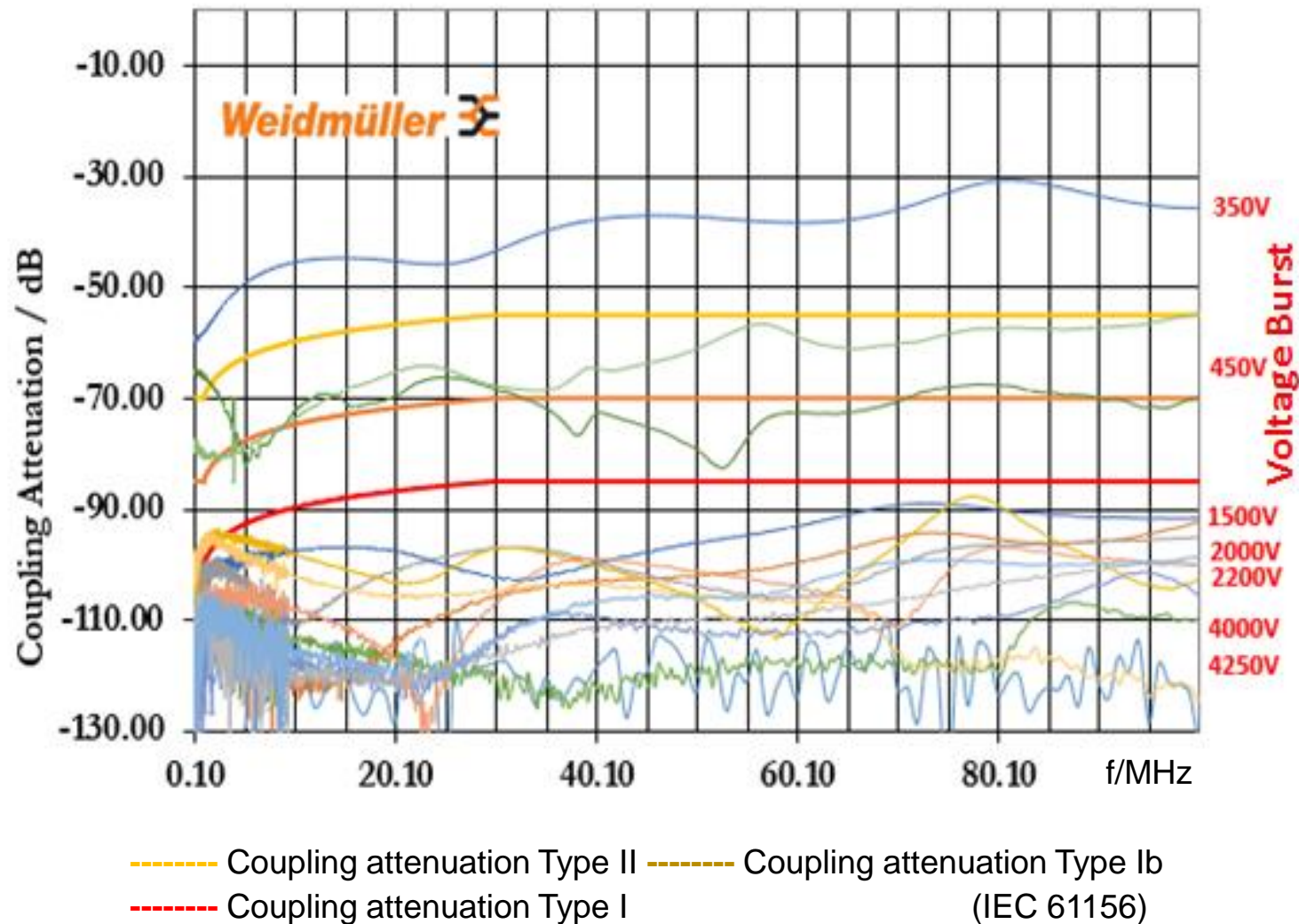

During the modified burst tests here, the voltage was increased step by step. The level of the interference signal amplitude, at which the first errors occur in the transmitted data packets, was recorded.

Although there is no linear relationship between coupling attenuation and burst test, it is shown, that cables with high coupling attenuation can withstand higher burst voltages.

- Burst requirements only in the E3 area (MICE environment)
- only shielded SPE cables meet E3 requirements
- unshielded SPE cables meet E1 & E2 requirements
- further measurements are necessary
- a mathematical description of the relationships is desirable
- repeated test with 10Base-T1 application is in progress

Conclusion & Outlook

- The unbalance attenuation a_U of a balanced cable describes, how much energy couples from the **differential mode** into the **common mode** (or vice versa).
- With the extension of IEC 62153-4-9 **Amd1** the low Frequency Coupling Attenuation **LFCA** can be measured now from 100 kHz upwards.
- **Coupling attenuation** of unshielded **single pairs** and connectors at near end is in principle the near end **unbalance attenuation** or the **TCL** of the test object.
- Alternatively to the measurement of **coupling attenuation**, the interference immunity of **SPE cables**, and **components** can be measured using the **burst test** according to IEC 61000-4-4 and evaluated according to IEC 61000-6-2
- The repetitive **fast transient test** according to IEC 61000-4-4 is a **test with bursts** consisting of a number of fast transients, coupled into power, control, signal and earth ports of the DUT.
- The **MICE table** according to **ISO/IEC 11801-1**, classifies the environment for generic cabling.
- Only shielded **SPE cables** meet E3 requirements, - **unscreened SPE cables** meet E1 & E2 requirements
- A mathematical description of the relationships is in preparation.
- Further measurements are necessary, a repeated test with **10Base-T1** application is in progress.