

Block TDECQ Test Method

Addressing comments: 256, 257, 258, 259,

Ali Ghiasi - Ghiasi Quantum/Marvell

Pavel Zivny – Self Employed

John Calvin – Keysight

IEEE 802.3dj Plenary Meeting

Vancouver, Canada

November 16, 2024

List of Supporters

- ❑ Karl Muth – Broadcom
- ❑ Bill Simms – Nvidia.

Overview

- ❑ Concern about TDECQ not capturing jitter
- ❑ Does TDECQ capture jitter
- ❑ Correlation of J_{RMS} with EECQ/TDECQ
- ❑ Background on SONET jitter generation
- ❑ Weakness in current JTOL
- ❑ What maybe the real problem
- ❑ Summary.

Improving TDECQ Test Method

- ❑ **Concern raised that high phase noise in the 4-100 MHz may cause error floor, see [ran 3dj elec 01 240822](#)**
 - Ran suggest adding J3U test to TP2 can protect the receiver
- ❑ **[Ghiasi 3dJ 01 2409](#) investigated number of issues around TDECQ test method which may explain lack of correlation to receiver sensitivity**
 - The biggest issue maybe due to measuring TDECQ in non-mission mode where no jitter passes through the CDR – it's a must
 - Ghiasi showed that TDECQ does capture already correct J3U jitter but the moule must be in the mission mode – J3U not needed since already captured by TDECQ
 - TDECQ with SSPRQ can capture jitter to ~1.6 MHz and may need to add phase noise measurement – not clear if required
- ❑ **[Mi 3dJ 02a 2409](#) investigate possible method how to better define TECQ/TDECQ to capture effect of block errors – will improve TECQ/TDECQ correlation to post-FEC**
 - We can devise a Golden hardware receiver that may/may not be commercially available
 - As was suggested by [healey 3dj 02a 2409](#) can we do something similar with TDECQ as that would be the ideal solution?

Configuring DUT Module Test for Mission Mode

- ❑ **The module is configured into mission mode with worst case stress signal that include SJ applied to TP1**
 - The data pattern applied to TP1 are one of following PRBS31Q, valid FEC encoded data, or SSPRQ
 - When PRBS31Q or valid FEC encoded data are used the CDR recovered clock is used to drive the CMU with SSPRQ pattern
 - If the CDR can tolerate operating with SSPRQ then CDR-CMU are put in passthrough mode
- ❑ **Crosstalk optical source is active and applied at TP3 that passes to TP4 during TDECQ mission mode testing.**

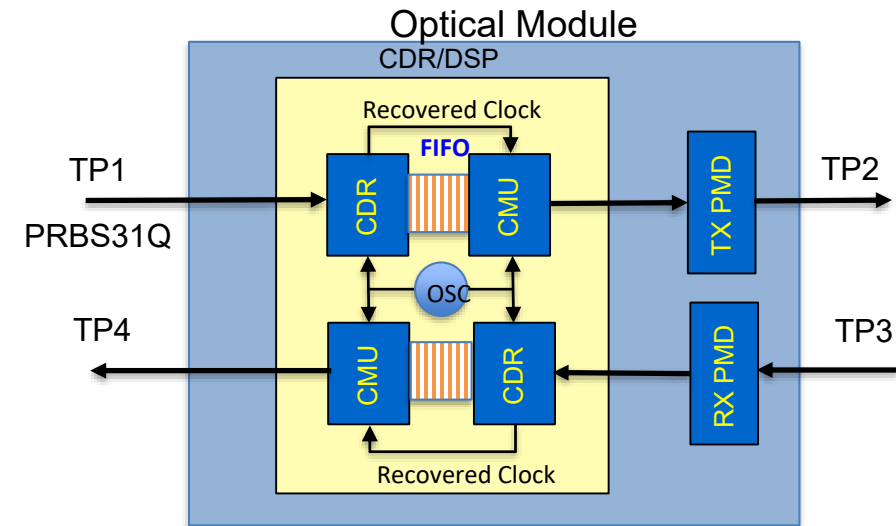

EECQ/TDECQ Correlation to Input Jitter

- ❑ Simulation show that there is strong correlation between EECQ/TDECQ and J3U as function of input J_{RMS}
 - J3U is a redundant measurement that is less effective than EECQ/TDECQ measured with a more representative SSPRQ pattern
- ❑ EECQ/TDECQ are very effective to capture jitter
 - The key is to make sure stress input applied to module input propagates to TP2 for TDECQ test otherwise jitter or impact jitter peaking will not be captured by TDECQ test or any other test!

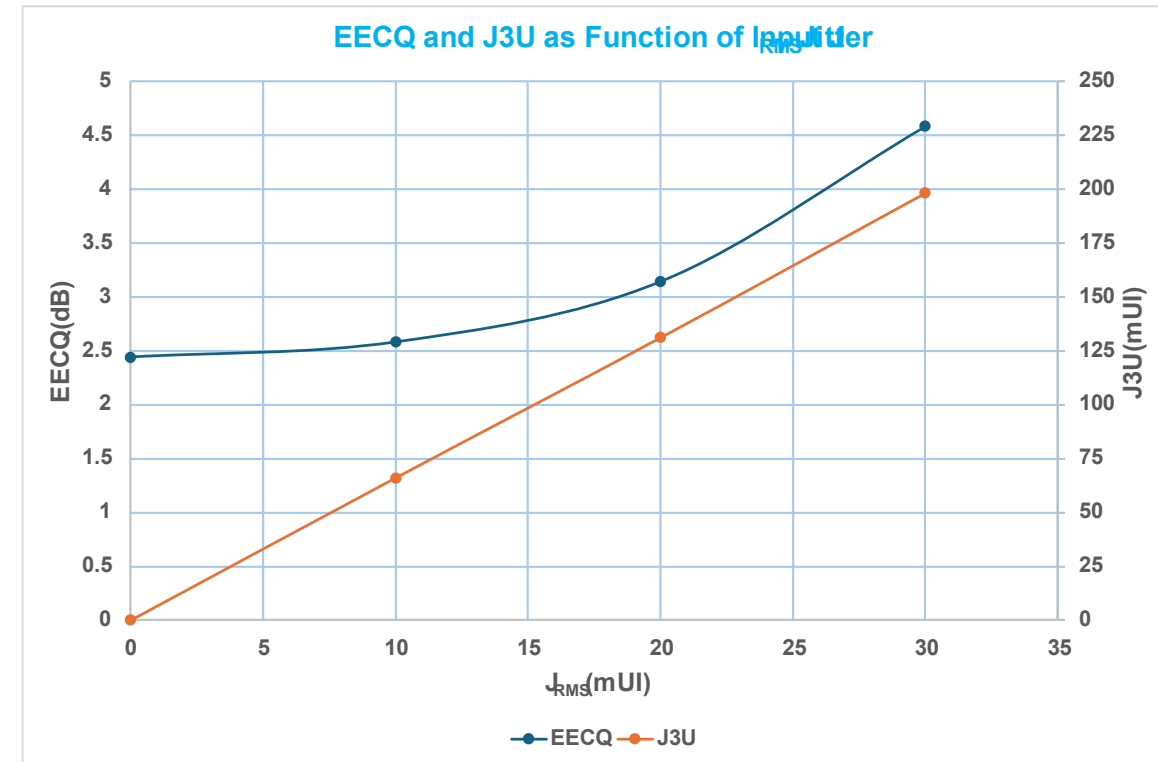

Current TDECQ SER Calculation

□ Two normalized histogram created (Left and Right) are created and associated function $F(y_i)$ equal to the number of sample captured divided by number of sample in the histogram window

- The sum of all $F(y_i)=1$
- Three cumulative probability functions are created for left and right histogram $F(y_i)$
 - The three histograms are for level 1, 2, 3
- The left cumulative function given below:

$$CF_{Li}(y_i) = \begin{cases} \sum_{y=P_{th1}}^{y_i} F(y) & \text{for } y_i \geq P_{th1} \\ \sum_{y=y_i}^{P_{th1}} F(y) & \text{for } y_i < P_{th1} \end{cases}$$

- Each element of CF_{L1} , CF_{L2} , and CF_{L3} are multiplied with associated threshold to partial SER for each level, then the 3 left cumulative distribution summed to get SER(left)
- The larger of SER_L or SER_R is used for TDECQ calculation.

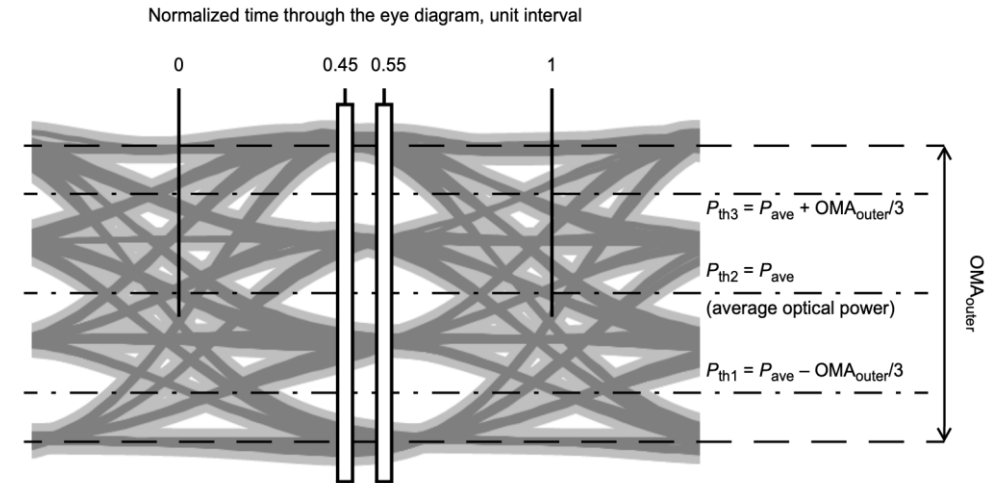
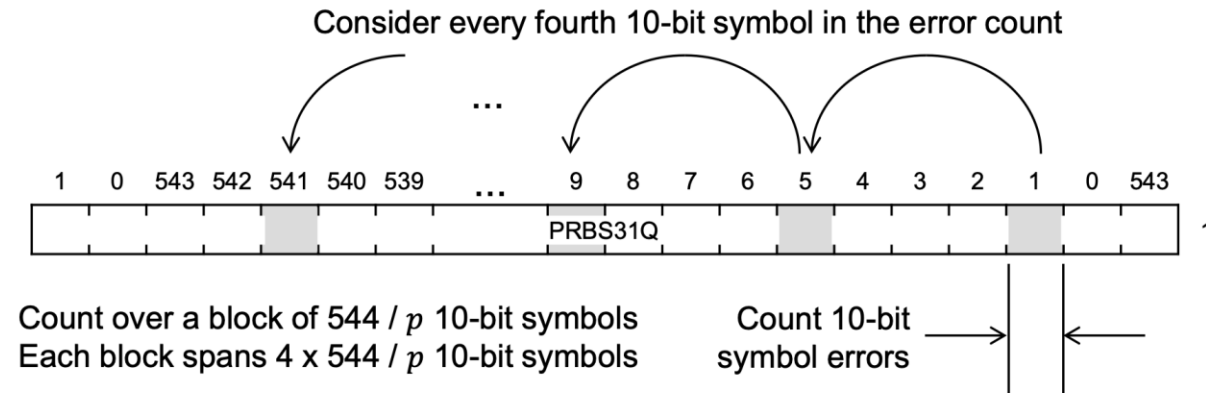
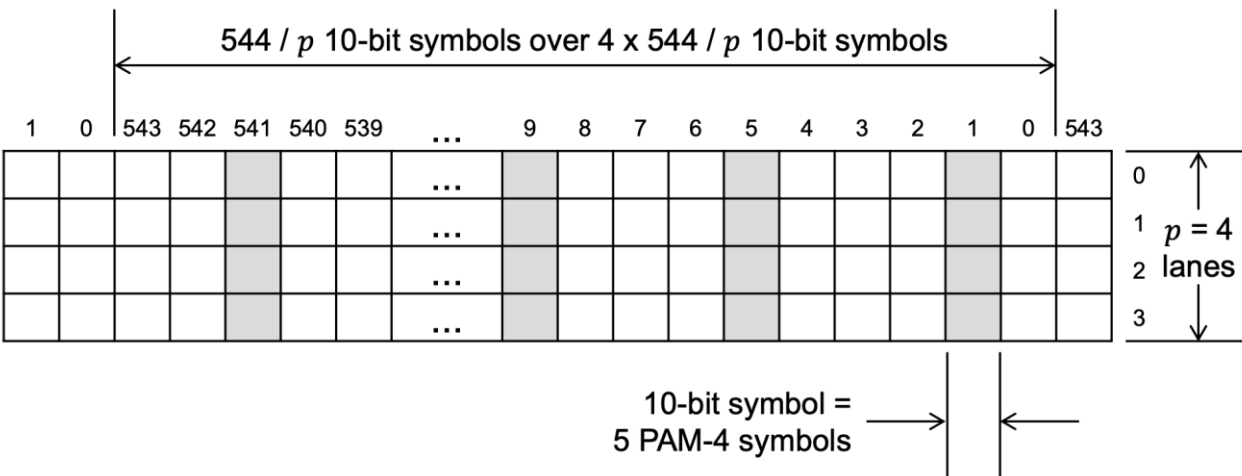

Figure 121-5—Illustration of the TDECQ measurement

Block Processing in TDECQ

□ Historically PRBS data has only provided average BER, but proposal from [healey 3dj 02a 2409](#) show mechanism to process PRBS data similar to FEC symbols block processing

- Exact same mechanism can be used for optical signal at TP2/TP3 with real HW receiver
- An ideal test method for optical transmitter is method independent of HW receiver
- Can we extend TDECQ method to capture block jitter/effects?



Extending TDECQ SER Calculation to FEC Blocks

- ❑ **The current TDECQ calculate SER_L or SER_R (PAM4 symbols)**
 - FEC block would consist of 5 PAM4 symbols
- ❑ **The advantage of Block TDECQ is that there is no need for Golden hardware receiver which may introduce its own block errors and may not even be available commercially**
 - Currently one full SPPRQ waveform is captured on the Oscilloscope for SER_L or SER_R and TDECQ calculation which takes ~ 3 seconds to capture
 - For Block TDECQ instead of one waveform ten waveforms are captured ~ 30 seconds to capture
 - SER_L or SER_R will be constructed from consecutive 5 PAM4 symbols
 - From every 10 blocks (50 PAM4 symbol) worst block is used for SER_L or SER_R calculation where σ_G is then adjusted to determine the TDECQ
 - With 10 waveform capture block TDECQ will also do a better job capturing lower frequency jitter effects
- ❑ **This method is similar to processing blocks with HW receiver except in case of Block TDECQ worst case SER blocks are used for TDECQ computation**
 - Block TDECQ when measured on Oscilloscope (sampling) the blocks are coming not from consecutive bits but rather at sampling rate of Oscilloscope but on real time scope blocks will be from consecutive bits
 - Given that 10 repetition of SPPRQ will be captured then worst 10% of blocks used for TDECQ calculation as long as signal is stationary worst blocks will be captured on the Oscilloscope
 - Block TDECQ might be little more conservative as worst-case block are selected over 10 symbol where if you select over larger window you allow for more burst.

Summary

- ❑ Concern raised by [ran 3dj elec 01 240822](#) receivers having some jitter sensitivity is unlikely that even SONET jitter generation test can distinguish good vs bad transmitters
 - Ran has stated that TDECQ doesn't capture jitter due to insufficient statistics, TDECQ with SSPRQ only require 3 seconds to provides statistically measurements
- ❑ [Ghiasi 3dJ 01 2409](#) showed that TDECQ already captures J3U/J4U
 - Low frequency jitter $< \sim 1.5$ MHz require PRBS31Q or FEC traffic that only phase noise measurement will capture these effect – not recommending to add phase noise at this point
 - Another key recommendation was that the TDECQ must be measured in mission mode – maybe the main reason for TDECQ discrepancy
- ❑ **There have been reports of compliant TDECQ transmitters resulting in high FEC codeword errors as stated above this is likely because the module are tested in non-mission mode but block TDECQ can further enhance TDECQ measurement if there are jitter events**
 - Block TDECQ by capturing 10 repetition of SSPRQ then only using worst 10% of blocks for SER and TDECQ will improve TDECQ-sensitivity correlation
 - Block TDECQ avoid using hardware receiver which may introduce its own block errors
 - Block TDECQ on Oscope expect to provide about the same TDECQ when measured on real time scope where blocks are coming from consecutive bits!