

Agenda and General Information

IEEE P802.3dq
Pin-Optimized PHY Interface Task Force

Jason Potterf
Cisco
Telephonic Interim Meeting, 2026-04-28

Agenda

- Welcome and Introductions
- Approve Agenda
- Goals for this meeting
- Big Ticket Items
- Reflector and Web
- Ground Rules
- IEEE
 - Structure, Bylaws and Rules
 - Call for Patents
 - IEEE Standards Process
- Future Meetings
- Presentations

General Decorum

- An officer of the Working Group or one of its subgroups, unless prohibited by the P & P of the Standards Committee or Working Group, is permitted to record the proceedings of an IEEE standards development meeting for which they are responsible by making an audio or slideshow recording or by producing a transcript using software or an artificial intelligence (AI) application approved by IEEE. **IEEE 802.3 meetings do not use this option.** Recording of the proceedings by any other participant or observer, in part or in whole, via any means, is prohibited. Software or AI shall not be used if it enables persons other than the officer making the recording or authorized Standards Department staff to initiate or obtain the transcription or recording. (March 2025 IEEE-SA Standards Board Operations Manual 5.3.3.2)
- Press (i.e., anyone reporting publicly on this meeting) are to announce their presence (March 2025 IEEE-SA Standards Board Operations Manual 5.3.3.3)

Teleconference Decorum

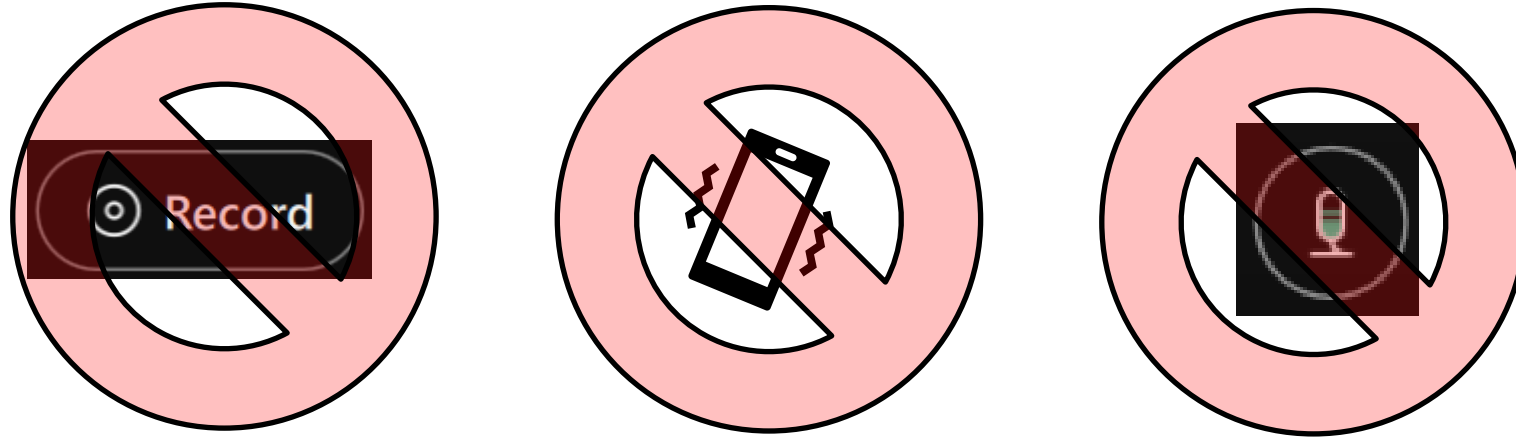

- Please **MUTE** unless actively speaking
- Send a chat message to “Everyone” to be placed into the queue
- The chat can only send to “Everyone” or the officers
- Please observe proper decorum in meetings

Goals for the meeting

- Review Technical Contributions

Big ticket items

- POPI Architecture

Reflector and Web

- To subscribe to the Pin-Optimized PHY Interface Study Group reflector, send an email to:

ListServ@ieee.org

with the following in the body of the message (do not include “<>”):

subscribe stds-802-3-POPI@listserv.ieee.org <yourfirstname> <yourlastname>
end

- Send Pin-Optimized PHY Interface Task Force reflector messages to:

stds-802-3-POPI@listserv.ieee.org

- Task Force web page URL:

<https://www.ieee802.org/3/dq/index.html>

Task Force Private Area

- No private area at this time

Ground Rules

- Based upon IEEE 802.3 Rules
 - Foundation based upon Robert's Rules of Order
 - Anyone in the room may speak
 - Anyone in the room may vote
- **RESPECT**... give it, get it
- NO product pitches
- NO corporate pitches
- NO prices!!!
 - This includes costs, ASPs, etc. no matter what the currency
- NO restrictive notices

Attendance

- Attendance taken from WebEx Meeting Report
- No credit towards voting rights is accrued during telephonic interims
- To gain and maintain voting rights, POPI participants must participate in other task forces during the various plenary and interim meeting series

IEEE Structure

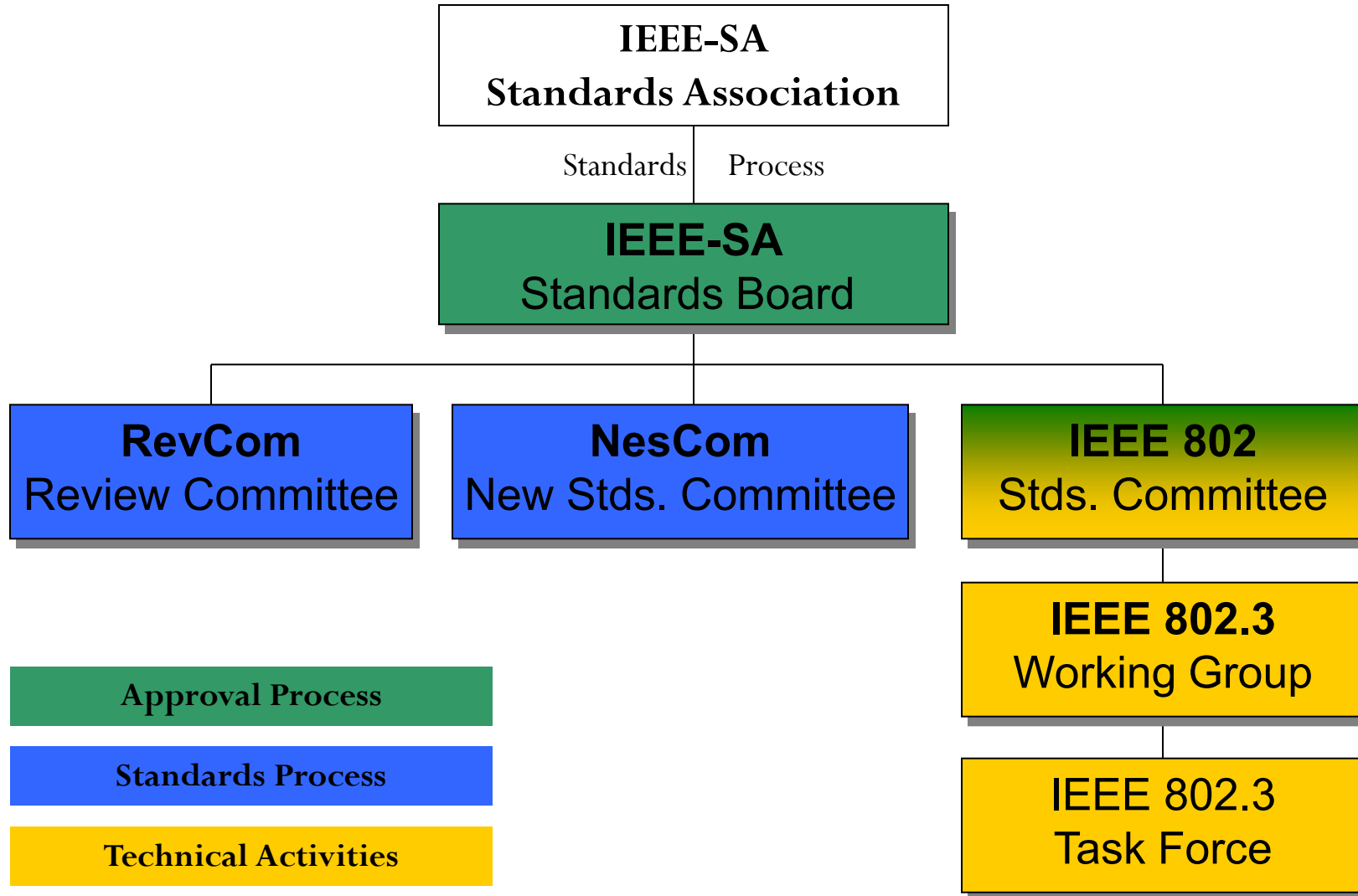

Important Bylaws and Rules

- **IEEE-SA Operations Manual**
http://standards.ieee.org/develop/policies/sa_opman/
- **IEEE-SA Standards Board Bylaws**
<http://standards.ieee.org/develop/policies/bylaws/>
- **IEEE-SA Standards Board Operations Manual**
<http://standards.ieee.org/develop/policies/opman/>
- **IEEE 802 LAN/MAN Standards Committee (LMSC) Policies and Procedures**
<https://ieee.app.box.com/v/PandP-LMSC>
- **IEEE 802 LAN/MAN Standards Committee (LMSC) Operations Manual**
<http://www.ieee802.org/devdocs.shtml>
- **IEEE 802 LAN/MAN Standards Committee (LMSC) Working Group (WG) Policies and Procedures**
<http://www.ieee802.org/devdocs.shtml>
- **IEEE 802.3 Working Group Operating Rules**
http://ieee802.org/3/rules/P802_3_rules.pdf

PARTICIPANTS HAVE A DUTY TO INFORM THE IEEE

- Participants shall inform the IEEE (or cause the IEEE to be informed) of the identity of each holder of any potential Essential Patent Claims of which they are personally aware if the claims are owned or controlled by the participant or the entity the participant is from, employed by, or otherwise represents
- Participants should inform the IEEE (or cause the IEEE to be informed) of the identity of any other holders of potential Essential Patent Claims

**Early identification of holders of potential
Essential Patent Claims is encouraged**

WAYS TO INFORM IEEE

- **Cause an LOA to be submitted to the IEEE SA (patcom@ieee.org); or**
- **Provide the chair of this group with the identity of the holder(s) of any and all such claims as soon as possible; or**
- **Speak up now and respond to this Call for Potentially Essential Patents**

If anyone in this meeting is personally aware of the holder of any patent claims that are potentially essential to implementation of the proposed standard(s) under consideration by this group and that are not already the subject of an Accepted Letter of Assurance, please respond at this time by providing relevant information to the WG Chair

OTHER GUIDELINES FOR IEEE WORKING GROUP MEETINGS

- All IEEE SA standards meetings shall be conducted in compliance with all applicable laws, including antitrust and competition laws.
 - Don't discuss the interpretation, validity, or essentiality of patents/patent claims.
 - Don't discuss specific license rates, terms, or conditions.
 - Relative costs of different technical approaches that include relative costs of patent licensing terms may be discussed in standards development meetings.
 - Technical considerations remain the primary focus.
 - Don't discuss or engage in the fixing of product prices, allocation of customers, or division of sales markets.
 - Don't discuss the status or substance of ongoing or threatened litigation.
 - Don't be silent if inappropriate topics are discussed. Formally object to the discussion immediately.

For more details, see *IEEE SA Standards Board Operations Manual*, clause 5.3.10 and *Antitrust and Competition Policy: What You Need to Know* at <http://standards.ieee.org/develop/policies/antitrust.pdf>

PATENT-RELATED INFORMATION

The patent policy and the procedures used to execute that policy are documented in the:

- *IEEE SA Standards Board Bylaws*
(<http://standards.ieee.org/develop/policies/bylaws/sect6-7.html#6>)
- *IEEE SA Standards Board Operations Manual*
(<http://standards.ieee.org/develop/policies/opman/sect6.html#6.3>)

Material about the patent policy is available at
<http://standards.ieee.org/about/sasb/patcom/materials.html>

**If you have questions, contact the
IEEE SA Standards Board Patent
Committee Administrator at
patcom@ieee.org**

IEEE SA COPYRIGHT POLICY

By participating in this activity, you agree to comply with the IEEE Code of Ethics, all applicable laws, and all IEEE policies and procedures including, but not limited to, the IEEE SA Copyright Policy.

- Previously Published material (copyright assertion indicated) shall not be presented/submitted to the Working Group nor incorporated into a Working Group draft unless permission is granted.
- Prior to presentation or submission, you shall notify the Working Group Chair of previously Published material and should assist the Chair in obtaining copyright permission acceptable to IEEE SA.
- For material that is not previously Published, IEEE is automatically granted a license to use any material that is presented or submitted.

IEEE SA COPYRIGHT POLICY

- The IEEE SA Copyright Policy is described in the IEEE SA Standards Board Bylaws and IEEE SA Standards Board Operations Manual
 - IEEE SA Copyright Policy, see
 - Clause 7 of the IEEE SA Standards Board Bylaws
<https://standards.ieee.org/about/policies/bylaws/sect6-7.html#7>
 - Clause 6.1 of the IEEE SA Standards Board Operations Manual
<https://standards.ieee.org/about/policies/opman/sect6.html>
- IEEE SA Copyright Permission
 - <https://standards.ieee.org/content/dam/ieee-standards/standards/web/documents/other/permissionltrs.zip>
- IEEE SA Copyright FAQs
 - <https://standards.ieee.org/faqs/copyrights/>
- IEEE SA Best Practices for IEEE Standards Development
 - http://standards.ieee.org/develop/policies/best_practices_for_ieee_standards_development_051215.pdf
- Distribution of Draft Standards (see 6.1.3 of the SASB Operations Manual)
 - <https://standards.ieee.org/about/policies/opman/sect6.html>

Participant behavior in IEEE-SA activities is guided by the IEEE Codes of Ethics & Conduct

All participants in IEEE-SA activities are expected to adhere to the core principles underlying the:

- [IEEE Code of Ethics](#)
- [IEEE Code of Conduct](#)

The core principles of the IEEE Codes of Ethics & Conduct are to:

- *Uphold the highest standards of integrity, responsible behavior, and ethical and professional conduct*
- *Treat people fairly and with respect, to not engage in harassment, discrimination, or retaliation, and to protect people's privacy.*
- *Avoid injuring others, their property, reputation, or employment by false or malicious action*

The most recent versions of these Codes are available at <http://www.ieee.org/about/corporate/governance>

Participants in the IEEE-SA “*individual process*” shall act independently of others, including employers

The [IEEE-SA Standards Board Bylaws](#) require that “*participants in the IEEE standards development individual process shall act based on their qualifications and experience*”

This means participants:

- **Shall act & vote** based on their personal & independent opinions derived from their expertise, knowledge, and qualifications
- **Shall not act or vote** based on any obligation to or any direction from any other person or organization, including an employer or client, regardless of any external commitments, agreements, contracts, or orders
- **Shall not direct** the actions or votes of other participants or retaliate against other participants for fulfilling their responsibility to act & vote based on their personal & independently developed opinions

By participating in standards activities using the “*individual process*”, you are deemed to accept these requirements; if you are unable to satisfy these requirements then you shall immediately cease any participation

IEEE SA standards activities shall allow the fair & equitable consideration of all viewpoints

The [*IEEE SA Standards Board Bylaws*](#) (clause 5.2.1.3) specifies that “the standards development process shall not be dominated by any single interest category, individual, or organization”

- This means no participant may exercise “authority, leadership, or influence by reason of superior leverage, strength, or representation to the exclusion of fair and equitable consideration of other viewpoints” or “to hinder the progress of the standards development activity”

This rule applies equally to those participating in a standards development project and to that project’s leadership group

Any person who reasonably suspects that dominance is occurring in a standards development project is encouraged to bring the issue to the attention of the Standards Committee or the project’s IEEE SA Program Manager

Participants in attendance at IEEE Standards development activity meetings shall follow appropriate meeting decorum, and the SA meeting rules, including but not limited to:

- Recording (e.g., via audio, video, photography, artificial intelligence (AI) application or other software) of the proceedings by any participant or observer other than Officers of this IEEE standards development group, in part or in whole, via any means, is NOT permitted. (See IEEE Standards Board Operations Manual subclause 5.3.3.2 Recordings of the proceedings of standards development meetings)
- Participants intending to report publicly on this meeting (e.g., news outlets, social media, or online forums) shall inform the Chair of their attendance and the Chair shall announce their presence and their intent to report publicly. (See IEEE Standards Board Operations Manual Subclause 5.3.3.3 Press attendance)
- Participants shall comply with IEEE SA Standards Board Operations Manual 5.1.4 Standards promotion and social media communication

IEEE ETHICS REPORTING LINE

Ethics Reporting Line

Attention!

This web page is hosted on EthicsPoint's (owned and operated by NAVEX) secure servers and is not part of the Institute of Electrical and Electronics Engineers web site or intranet.



[Make a Report](#)

[Follow-up on a Report](#)

ETHICS AT IEEE

IEEE strives to achieve the highest standards of integrity and endeavors to conduct business around the world in a responsible and ethical way. It is important that those who act on the organization's behalf ensure IEEE's compliance by adhering to the same standards and expectations.

When you become aware of or suspect a violation of IEEE's Code of Ethics, Code of Conduct or Policies, raising your concern should be as easy as possible. For this reason, IEEE has selected EthicsPoint, an independent third party for the receipt and resolution of reports of impropriety. The information you provide will be sent to IEEE by EthicsPoint on an entirely confidential (and, if you choose, anonymous) basis. (For more information see, [IEEE's Ethics Reporting Line FAQ](#))

We will review every concern raised using a defined process to ensure fairness and consistency as defined in IEEE's Bylaws and Policies. We will treat you with dignity and respect throughout the process. You can trust that we will handle your question or concern seriously and as soon as practicable. If something needs to be addressed, we will take action based on what we learn.

ETHICSPPOINT IS NOT A 911 OR EMERGENCY SERVICE:

Do not use this site to report events presenting an immediate threat to life or property. Reports submitted through this service may not receive an immediate response. If you require emergency assistance, please contact your local authorities.

TO MAKE A REPORT

You may use either of the following two methods to submit a report: dial toll-free, within the United States, Guam, Puerto Rico, and Canada: **+1 888 359 6323** Or select the "**Make a Report**" link at the top of this Web page.

After you complete your report, you will be assigned a unique code called a "report key." Write down your report key and password and keep them in a safe place. After **7-10** business days, use your report key and password to check your report for feedback or questions.

Please be aware that the IEEE Ethics Reporting Line will only accept complaints regarding IEEE's business and activities. IEEE will not review or accept complaints regarding any other organization, including the employers of members. IEEE members seeking ethical assistance regarding their employers should seek their own counsel or consult their employers.

NON-RETALIATION POLICY

It is the policy of IEEE not to take any retaliatory action against any director, officer, manager, employee or volunteer for raising a good faith compliance or ethics concern, for making a good faith report of a possible violation of the IEEE Code of Ethics, Code of Conduct or IEEE Policies, or assisting or cooperating in an investigation of a possible violation.

Any elected director or officer of IEEE and any staff manager or employee who engages in any such retaliatory action can be punished by penalties up to and including expulsion from IEEE membership for a volunteer and termination of employment for any IEEE staff member.

OTHER COMPLIANCE INQUIRIES may be directed to compliance@ieee.org.

Reports alleging violations of IEEE's Code of Conduct, Code of Ethics, or other policies and rules, can be reported in two ways:

- **Phone:** +1 888-359-6323
- **Web:** www.ieee-ethics-reporting.org

Under IEEE Bylaw I-110 and IEEE Policy 7.10, any individual may report an allegation of misconduct against a member, or a non-member engaged in an IEEE activity. Reports may be filed anonymously.

References

Code of Ethics:

<https://www.ieee.org/about/corporate/governance/p7-8.html>

Code of Conduct:

<https://www.ieee.org/about/corporate/governance/code-of-conduct.html>

Overview of IEEE 802.3 Standards Process (1/5)- Study Group Phase

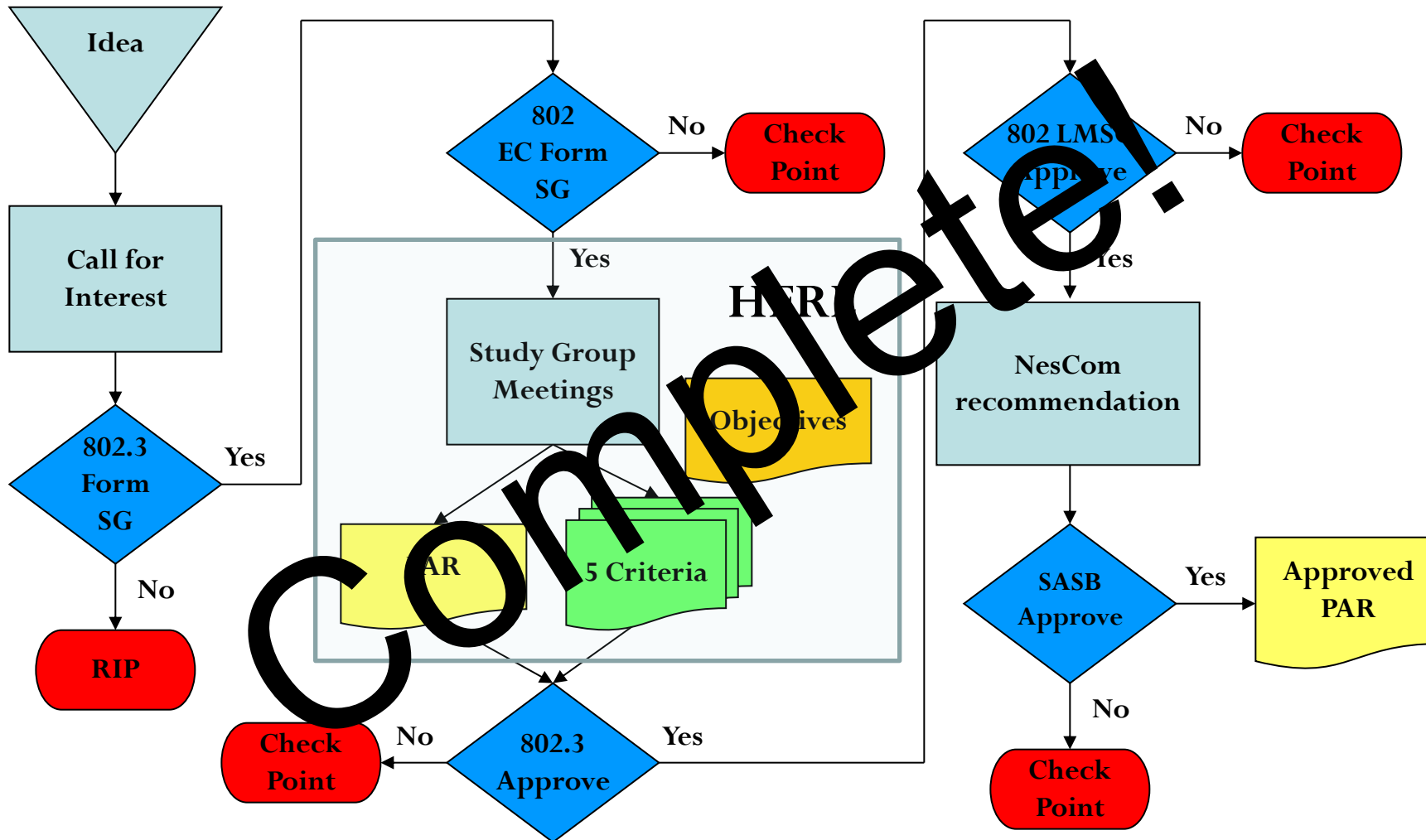

Note: At "Check Point", either the activity is ended, or there may be various options that would allow reconsideration of the approval.

Overview of IEEE 802.3 Standards Process (2/5) – Task Force Comment Phase

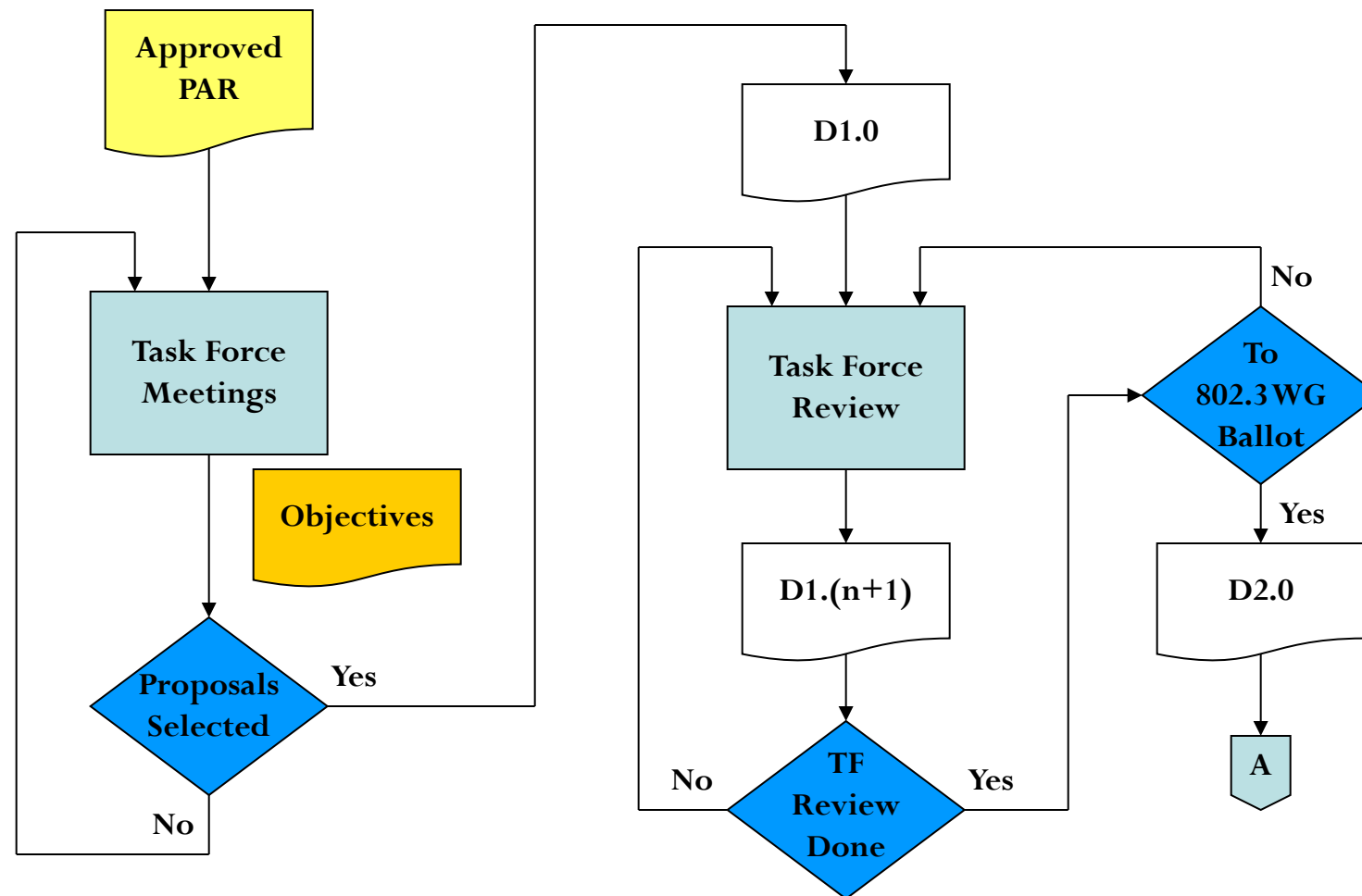

Overview of IEEE 802.3 Standards Process (3/5) – Working Group Ballot Phase

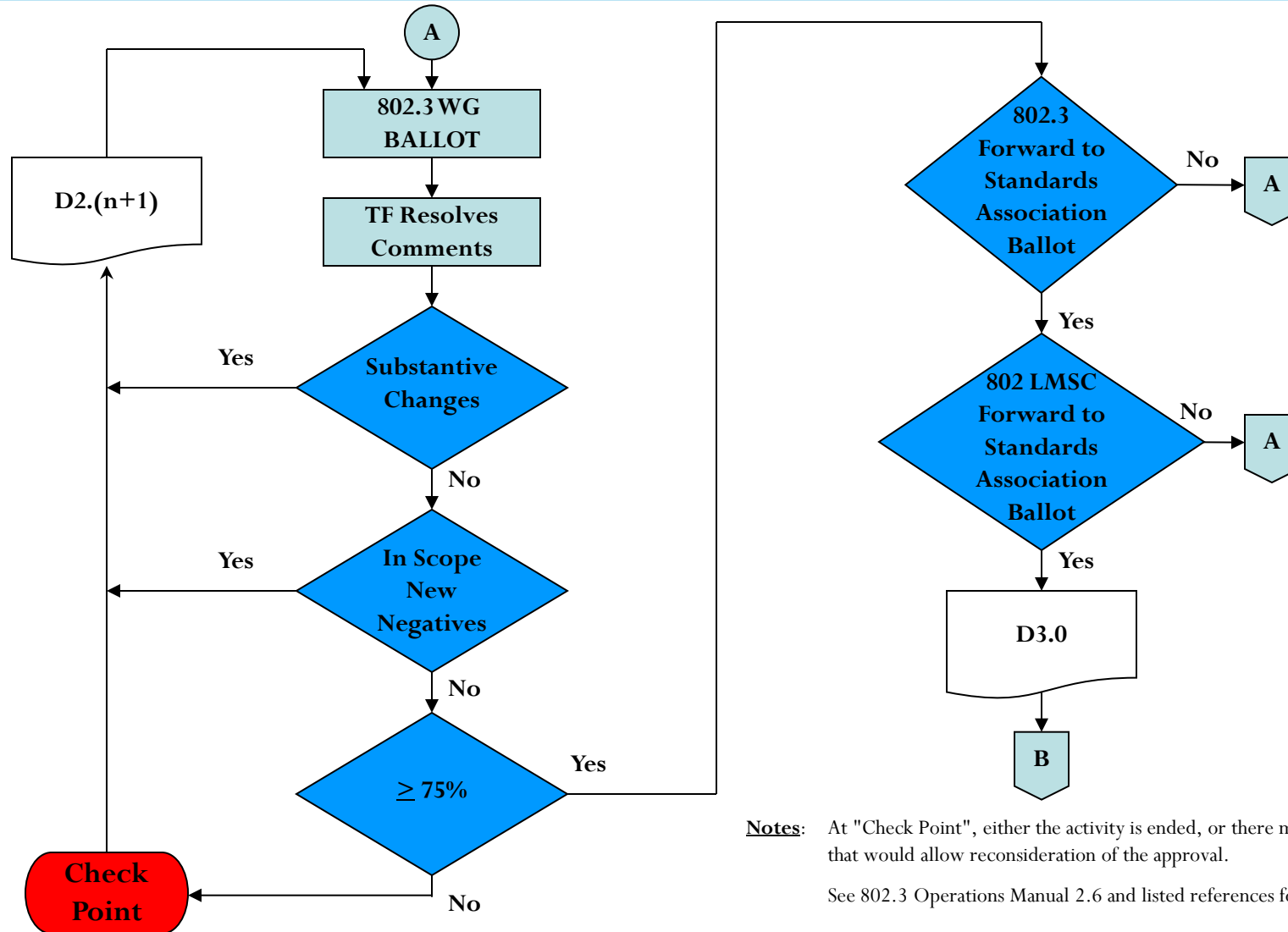

Notes: At "Check Point", either the activity is ended, or there may be various options that would allow reconsideration of the approval.

See 802.3 Operations Manual 2.6 and listed references for complete description

Overview of IEEE 802.3 Standards Process (4/5)- IEEE Standards Association (SA) Ballot Phase

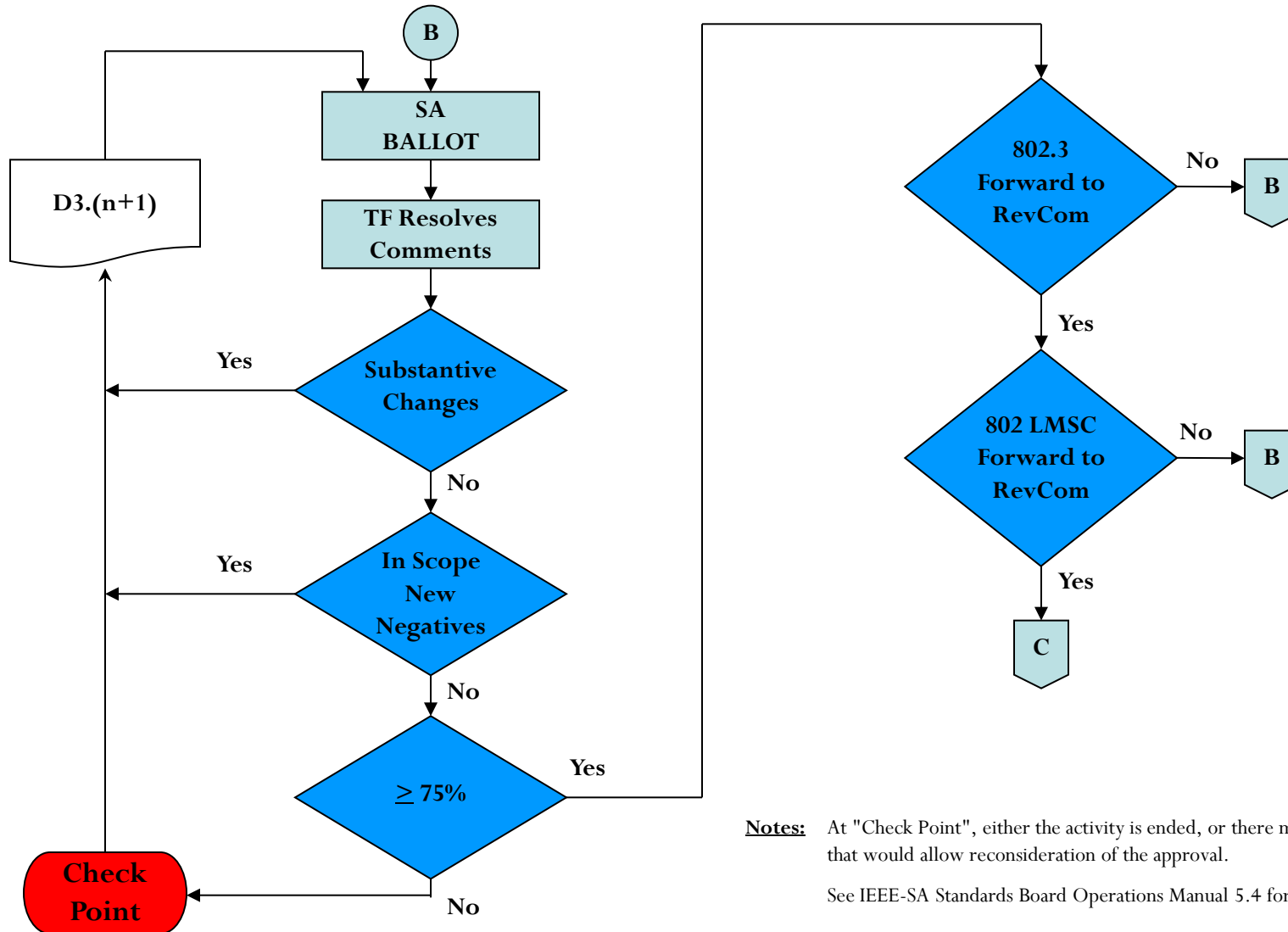

Notes: At "Check Point", either the activity is ended, or there may be various options that would allow reconsideration of the approval.
See IEEE-SA Standards Board Operations Manual 5.4 for complete description

Overview of IEEE 802.3 Standards Process (5/5) – Final Approvals / Standard Release

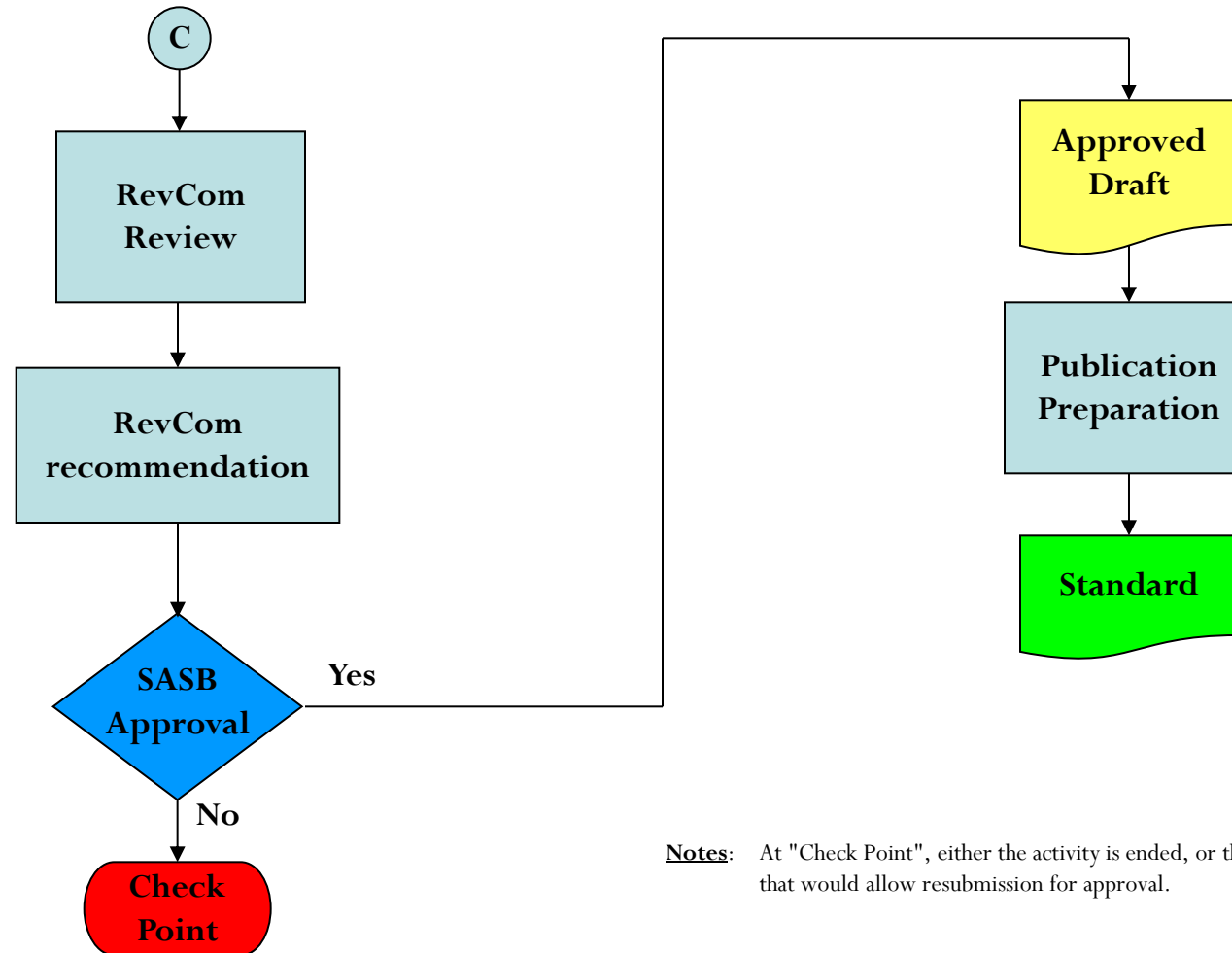

Notes: At "Check Point", either the activity is ended, or there may be various options that would allow resubmission for approval.

IEEE P802.3dq Pin-Optimized PHY Interface Task Force Approved Project Documents

- PAR
 - https://www.ieee802.org/3/dq/P802.3dq_PAR.pdf
- 5 Criteria
 - <https://mentor.ieee.org/802-ec/dcn/25/ec-25-0128-02-LMSC-ieee-p802-3dq-draft-csd.pdf>
- Objectives
 - https://www.ieee802.org/3/dq/POPI_DRAFT_Objectives_2025-06-18_v01.pdf

IEEE P802.3dq Pin-Optimized PHY Interface Task Force Objectives

- The following objectives have been updated by the Task Force and will be taken to the IEEE 802.3 Working Group for approval at an appropriate time

Basic Objectives

1. Define a scalable logical interface that can support arbitrary port speeds and counts while retaining as many of the feature in our Feature Objectives as possible.
2. Define a first electrical interface to provide connectivity to a single Ethernet port with 8 or fewer pins operating at line speeds up to 100 Mb/s.
 1. Provide single port connectivity without a ~~SerDes~~-mandating clock recovery from the data.
3. Define a second electrical interface to provide connectivity to as many as 8 ports using 8 or fewer pins, each with speeds up to 100 Mb/s.
 1. Provide eight-port connectivity with an interface speed not to exceed 2 Gbps.
4. Do not preclude compatibility between the logical interface and 802.3 PHY types that are specified with GMII or XGMII.

Feature Objectives

1. Provide an extensible communications channel for non-packet data that is carried on the POPI interface pins.
2. Support an error-checked MDIO management interface over the extensible communications channel for non-packet data.
3. Support Energy Efficient Ethernet (EEE).
4. Support half-duplex operation.
5. Support Clause 148 PLCA.
6. Support full-duplex operation.
7. Support auto-negotiation (e.g. Clause 28, Clause 98)

Compatibility Objectives

1. Preserve the Ethernet frame format and content
2. Do not specify further modifications to the preamble and SFD
3. Specify a logical and electrical interface between the Media Access Control (MAC)-Physical Signaling Sublayer (PLS) and the following Physical Coding Sublayers specified in:
 1. Clause 96 (100BASE-T1)
 2. Clause 97 (1000BASE-T1)
 3. Clause 146 (10BASE-T1L)
 4. Clause 147 (10BASE-T1S)
 5. Clause 148 (PLCA)
4. Do not preclude support for other existing PHYs specified in 802.3
5. Do not preclude support for proposed 100BASE-T1L PHYs (P802.3dg - Clause 190).
6. Do not preclude support for proposed 10BASE-T1M PHYs (P802.3da - Clause 188).
7. Do not preclude the transmission of PTP timestamps across the interface using in-band data.

IEEE P802.3dq *Pin-Optimized* PHY Interface Task Force Timeline

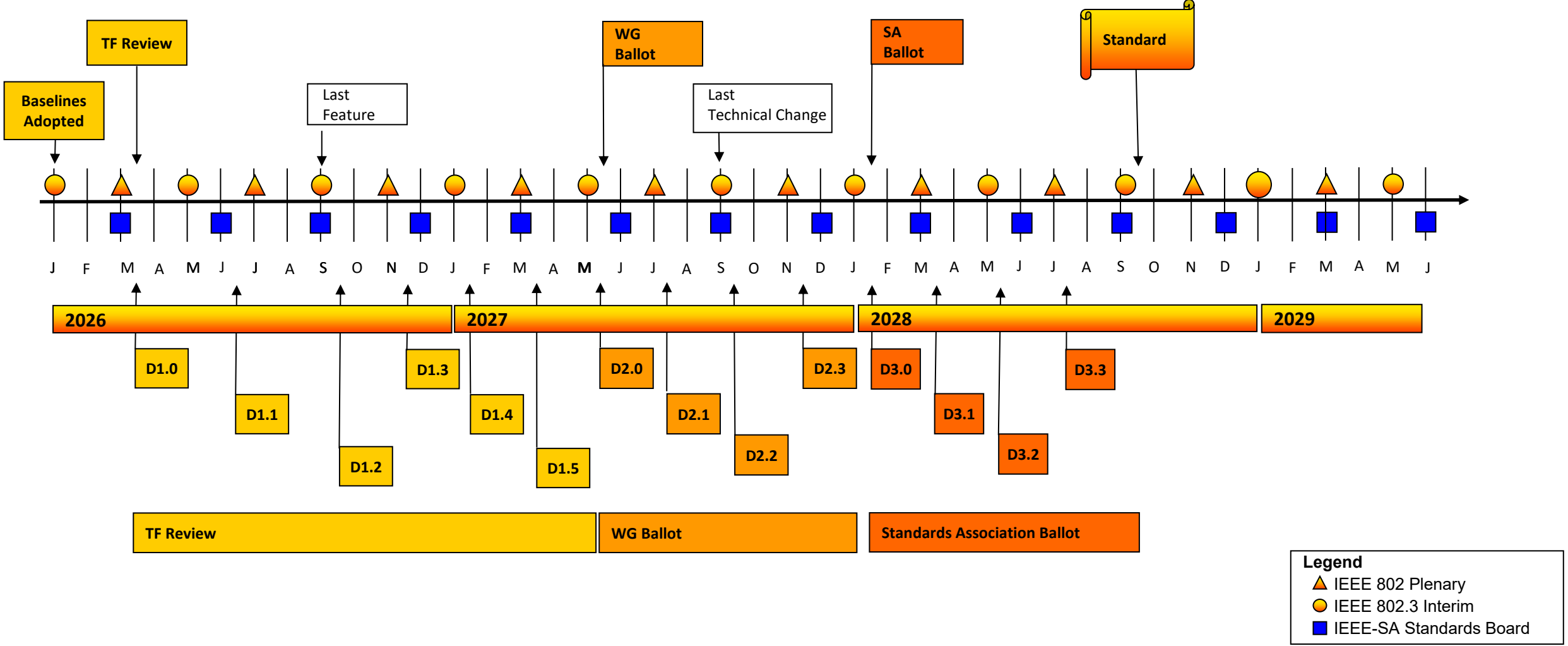

Legend

- ▲ IEEE 802 Plenary
- IEEE 802.3 Interim
- IEEE-SA Standards Board

Future Meetings

- See: <http://www.ieee802.org/3/interims/index.html>
- May IEEE 802.3 Interim in Munich, Germany
 - Registration: <https://www.eventcreate.com/e/ieee-802-3-802-1-may>
- POPI Meeting Timeslot:
 - 8 AM Pacific US / 10 AM Central US / 11 AM Eastern US / 4 PM GMT for 2 hours
- Next Virtual Instance(s):

Presentation Request Deadline	Presentation Submission Deadline	Meeting Date
TBD	TBD	TBD

- Anyone interested in hosting an interim meeting contact me or the IEEE 802.3 Executive Secretary [Chad Jones](#).

Presentations

- **Single and Multi-Port 10/100M PHY POPI Requirements**
 - Brian Murray, Jacobo Riesco
 - Employed by and affiliated with Analog Devices, Inc.
- **POPI Sideband MicroFrame Format Proposal**
 - Jason Potterf
 - Employed by and affiliated with Cisco Systems

Note –Times listed are subject to change.

Thank You!